



Aalborg Universitet

AALBORG UNIVERSITY
DENMARK

State-of-the-art Review : Vol. 2B. Methods and Tools for Designing Integrated Building Concepts

Andresen, Inger; Kleiven, Tommy; Knudstrup, Mary-Ann; Heiselberg, Per Kvols; van der Aa, Ad; Andresen, Inger; Asada, Hideo; Bluemel, Ernst; Marques da Silva, Fernando; Haase, Matthias; Hansen, Hanne Tine Ring; Hayashi, Tatsuya; Heiselberg, Per Kvols; Hori, Yuji; Kato, Shinsuke; Knudstrup, Mary-Ann; Kolarik, Jakub; Kolokotroni, Maria; Miura, Mitsuki; Nishizawa, Shigeki; Satake, Akira; Sawachi, Takao; Tochigi, Manabu; Yanai, Takashi; Yoshie, Ryuichiro; Wahlström, Åsa; Warwick, David

Publication date:
2008

Document Version
Publisher's PDF, also known as Version of record

[Link to publication from Aalborg University](#)

Citation for published version (APA):

Andresen, I. (Ed.), Kleiven, T. (Ed.), Knudstrup, M-A. (Ed.), Heiselberg, P. (Ed.), van der Aa, A., Andresen, I., ... Warwick, D. (2008). State-of-the-art Review : Vol. 2B. Methods and Tools for Designing Integrated Building Concepts: NNEX 44 : Integrating Environmentally Responsive Elements in Buildings. Aalborg: Department of Civil Engineering, Aalborg University. (DCE Technical Reports; No. 49, Vol. 2b.).

General rights

Copyright and moral rights for the publications made accessible in the public portal are retained by the authors and/or other copyright owners and it is a condition of accessing publications that users recognise and abide by the legal requirements associated with these rights.

- ? Users may download and print one copy of any publication from the public portal for the purpose of private study or research.
- ? You may not further distribute the material or use it for any profit-making activity or commercial gain
- ? You may freely distribute the URL identifying the publication in the public portal ?

Take down policy

If you believe that this document breaches copyright please contact us at vbn@aub.aau.dk providing details, and we will remove access to the work immediately and investigate your claim.



State-of-the-art Review

Vol. 2B. Methods and Tools for Designing Integrated Building Concepts

Inger Andresen, Tommy Kleiven, Mary-Ann Knudstrup, Per Heiselberg (editors)

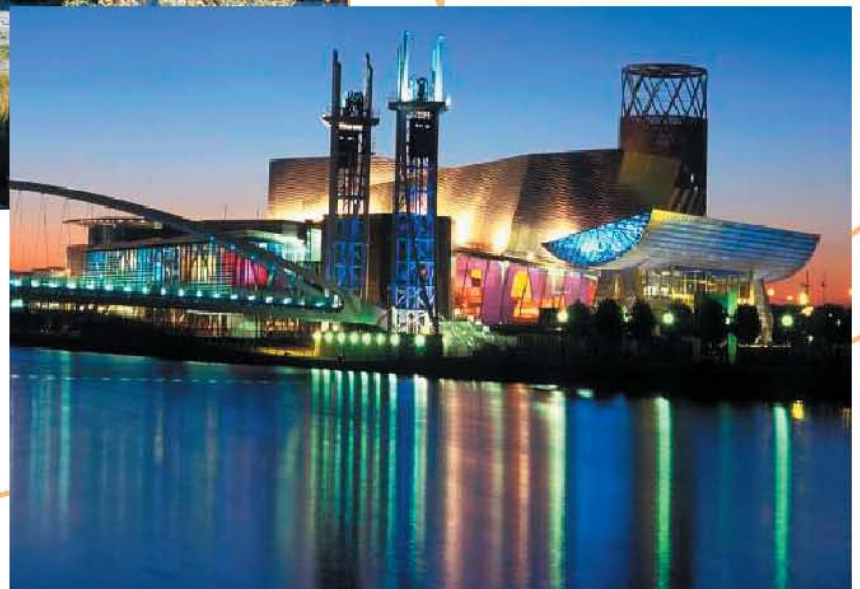

International Energy Agency
**Energy Conservation in
Buildings and Community
Systems Programme**

Annex 44 Website: www.civil.aau.dk/Annex44

Acknowledgements

The following experts contributed to this report:

Ad van der Aa

Cauberg-Huygen Consulting Engineers

PO Box 9222

3007 AE Rotterdam

The Netherlands

Phone: + 31 10 4257444; Fax: + 31 10 4254443; E-mail: a.vanderaa@chri.nl

Inger Andresen

SINTEF Building Research

Architecture and Building Technology

Alfred Getz Vei 3

7033 Trondheim

Norway

Phone: + 47 92207049; Fax: + 47 73 598285; E-mail: Inger.andresen@sintef.no

Hideo Asada

UKAJI Building Energy and Environment Research Institute

Japan

E-mail: h_asada@ukj.co.jp

Ernst Bluemel

AEE INTEC

Feldgasse 19

8200 Gleisdorf

Austria

Phone: + 43 3112 5886 25; Fax: + 43 3112 5886 18; E-mail: e.bluemel@aec.at

Fernando Marques da Silva

LNEC, National Laboratory for Civil Engineering

Av. do Brasil, 101

1700-066 Lisboa

Portugal

Phone: + 351 218 443 862; Fax: + 351 218 443 025; E-mail: fms@lnec.pt

Matthias Haase

Hong Kong University

Pokfulam Road

SAR Hong Kong

China

Phone: + 852 2241 5839; Fax: + 852 2559 6484; E-mail: mathaase@hkusua.hku.hk

Hanne Tine Ring Hansen

Architecture and Design
Aalborg University
Østeraagade 6
9000 Aalborg
Denmark
Phone: + 45 9635 7179; Fax: -; E-mail: htrh@aod.aau.dk

Tatsuya Hayashi

NIKKEN SEKKEI LTD
2-18-3 Iidabashi,
Chiyoda-ku, Tokyo 102-8117
Japan
Phone: + 81 (3) 52263030; Fax: + 81 (3) 52263039; E-mail: hayashit@nikken.co.jp

Per Heiselberg

Indoor Environmental Engineering
Aalborg University
Sohngaardsholmsvej 57
9000 Aalborg
Denmark
Phone: + 45 9635 8541; Fax: + 45 9814 8243; E-mail: ph@bt.aau.dk

Yuji Hori

Building Research Institute
Department of Environmental Engineering
Tachihara 1 Tsukuba, Ibaraki, 305-0802
Japan
Phone:+81-29-879-0609; Fax:+81-29-864-6775; E-mail: hor@kenken.go.jp

Shinsuke Kato

Institute of Industrial Science, University of Tokyo
4-6-1 Komaba Meguro-ku Tokyo,
JAPAN
Phone: + 81 (0) 3-5452-6431; Fax + 81 (0) 3-5452-6432; E-mail: kato@iis.u-tokyo.ac.jp

Mary-Ann Knudstrup

Architecture & Design
Aalborg University
Gl. Torv 6
9000 Aalborg
Denmark
Phone: + 45 9635 9910; Fax: + 45 9813 6705; E-mail: Knudstrup@aod.aau.dk

Jakub Kolarik

Int. Centre of Indoor Environment and Energy
DTU
Nils Koppels Allé, Building 402
2800 Kgs. Lyngby
Denmark
Phone: +44 2882 9959; Fax: +45 4545932166; E-mail: jak@mek.dtu.dk

Maria Kolokotroni

Brunel University
Mechanical Engineering
Uxbridge Campus
Uxbridge, UB8 3PH
United Kingdom
Phone: +44 1895 266688; Fax: +44 2895 256392; E-mail: Maria.Kolokotroni@brunel.ac.uk

Mitsuki Miura

The Kansai Electric Power Co.,Inc.
Building Energy Group
Civil and Architecture Department
6-16, Nakanoshima, 3-chome
Kita-ku, Osaka, 530-8270
Japan
Phone:+81-6-6441-8821;Fax:+81-6-6446-6464; E-mail: miura.mitsuki@c5.kepco.co.jp

Shigeki Nishizawa

Building Research Institute
Department of Environmental Engineering
Tachihara 1 Tsukuba, Ibaraki, 305-0802
Japan
Phone:+81-29-864-6683; Fax:+81-29-864-6775; E-mail: nisizawa@kenken.go.jp

Akira Satake

Technical Institute of Maeda Corporation
1-39-16 Asahi-cho Nerima-ku, Tokyo 179-8914
Japan
Phone: + 81 (0) 3-3977-2245, Fax: + 81 (0) 3-3977-2251; E-mail: satake.a@jcity.maeda.co.jp

Takao Sawachi

National Institute for Land and Infrastructure Management
1 Tatehara
Tsukuba 305-0802
Japan
Phone: + 81 298 64 4356; Fax: + 81 298 64 6774; E-mail: sawachi-t92ta@nilim.go.jp

Manabu Tochigi

NIHON SEKKI, INC.

Environment & MEP Engineering Dept

29th FL.,Shinjuku I-LAND Tower,6-5-1,Nishi-shinjuku,Shinjuku,Tokyo 163-1329

Japan

Phone: + 81 (0) 3-5325-8403, Fax: + 81 (0) 3-5325-8457;

E-mail: tochigi-m@nihonsekkei.co.jp**Takashi Yanai**

NIHON SEKKI, INC.

Environment & MEP Engineering Dept

29th FL.,Shinjuku I-LAND Tower,6-5-1,Nishi-shinjuku,Shinjuku,Tokyo 163-1329

Japan

Phone: + 81 (0) 3-5325-8388, Fax: + 81 (0) 3-5325-8457; E-mail: yanai-t@nihonsekkei.co.jp**Ryuichiro Yoshie**

Tokyo Polytechnic University

Department of Architecture

1583 Iiyama, Atsugi, Kanagawa

Atsugi/Kanagawa 243-0297

Japan

Phone: + 81 (0) 46-242-9556; Fax: + 81 (0) 46-242-9556; E-mail: yoshie@arch.t-kougei.ac.jp**Åsa Wahlström**

SP Swedish National Testing and Research Institute

PO Box 857

501 15 Boraas

Sweden

Phone: + 46 33 16 55 89; Fax: + 46 33 13 19 79; E-mail: asa.wahlstrom@sp.se**David Warwick**

Buro Happold

2 Brewery Place, Brewery Wharf

Leeds, LS10 1NE

United Kingdom

Phone: + 44 113 204 2200; Fax: -; E-mail: David.warwick@burohappold.com

Contents

ACKNOWLEDGEMENTS	2
INTRODUCTION	7
THE INTEGRATED DESIGN PROCESS BY IEA TASK 23	10
THE INTEGRATED DESIGN PROCESS (IDP) BY KNUDSTRUP	15
INTEGRATED BUILDING DESIGN SYSTEM (IBDS).....	20
ECO-FACTOR METHOD.....	24
TRIAS ENERGETICA	29
ENERGY TRIANGLE.....	35
THE KYOTO PYRAMID	37
E-QUARTET.....	39
ECO-FACADE TOOL	43
LEHVE TOOL.....	48
VENTSIM – VENTILATION NETWORK ANALYSIS TOOL	51
COMPUTER SIMULATION TOOLS	55
UNCERTAINTY IN BUILDING PERFORMANCE ASSESSMENT	57

Definitions

Reactive Building Elements

Building construction elements that assist to maintain an appropriate balance between optimum interior conditions and environmental performance by reacting in a dynamic and integrated manner to changes in external or internal conditions or to occupant intervention, and by dynamically communicating with technical systems. Examples include:

- Facades systems (Double skin facades, adaptable facades, windows, shutters, shading devices, ventilation openings, green facades)
- Roof systems (Green roof systems)
- Foundations (Earth coupling systems)
- Storages (Phase change materials, active use of thermal mass materials (concrete, massive wood), core activation (cooling and heating))
- Whole room concepts

Whole Building Concepts

Integrated design solutions where reactive building elements together with service functions are integrated into one system to reach an optimal environmental and cost performance (see illustration on next page).

Environmental Performance

Environmental performance comprises energy performance with its related resource consumption, ecological loadings and indoor environmental quality (IEQ).

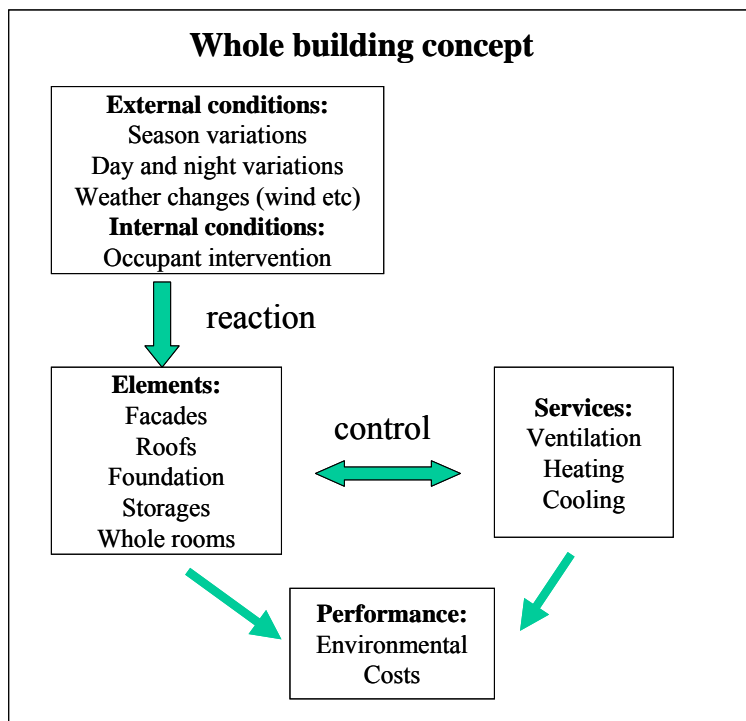

Illustration of the integration between building elements, indoor and outdoor conditions, controls, and performance (Illustration: Åsa Wahlström).

Introduction

The purpose of this report is to give examples of methods and tools that are used in the design of integrated building. The report does not aspire to give a complete overview of all possible design methods and tool. The report will serve as a common basis for the research and development work that is going to be carried out within the IEA Annex 44 project.

This report contains a description of 11 different methods and tools that the members of the IEA Annex 44 have contributed. In addition, the report contains a short overview of computer simulation tools that may be used to predict the performance of integrated building concepts and responsive building elements. At last, the report gives a description of uncertainty modelling in building performance assessment.

The descriptions of the design methods and tools include an explanation of how the methods may be applied, any experiences gained by using the methods, barriers for further use, and research needs.

Overview of the methods

Name	Origin	Year
The Integrated Design Process, Task 23	IEA SHCP Task 23 (International)	2003
The Integrated Design Process, Knudstrup	M-A.Knudstrup, Aalborg University, Denmark	2004
Integrated Building Design System, IBDS	K.Steemers, Cambridge University, UK	2005
The Eco-Factor Method	Erik Bjørn, Åsa Wahlström (Swedish National Testing and Research Institute, Henrik Brohus (Aalborg University)	2004
Trias Energetica	Ad van der Aa, Ir. Nick van der Valk, Cauberg-Huygen Consulting Engineers, The Netherlands	2005
Energy Triangle	Haase, M. and A. Amato, Hong Kong University	2005
The Kyoto Pyramid	T.H. Dokka, SINTEF, Norway	2004
E-Quartet	A. Satake, Maeda Corporation, Japan	
Eco-Facade	M. Kolokotroni (et al), Brunel University, UK	2004
LEHVE	T. Sawachi, NILIM, Japan	2005
VentSim	S. Nishizawa, Building Research Institute, Japan	

Although the methods contain many similar aspects, they may be organised into 5 main categories:

1) Design Process Methods/Tools

The first three methods can be described as process focused methods. They describe how to work during the design, what issues to focus on in what stages of design, how the issues may be organised, how they interact, etc. The Integrated Design Process Task 23 method can be characterised as a design process method with tools. The Integrated Design Process Knudstrup method is focused around a trans-disciplinary process approach to designing low energy buildings. Both of these methods use the architect's design process approach as the point of departure. The IBDS is more focused on design issues, and offers the possibility for a strategic interaction between the various parameters in the process. In this respect, the IBDS may also be described as a Design Strategy Method (see below).

2) Design Evaluation Methods/Tools

The design evaluation tools are typically used later in the design process to check the performance of a given design concept or to evaluate a specific design scheme and compare it to a benchmark or to another alternative scheme. The Eco-Factor Method and the VentSim tool fall into this category.

3) Design Strategy Methods/Tools

The Trias Energita, The Kyoto Pyramid and the Energy Triangle are methods that present a way to structure the technological design issues. They all stem from the Trias Energetica approach devised by Lysen (1996). They are based on the philosophy that the order of measures should be similar the “reduce-reuse-recycle” –principle, i.e. passive measures first, then renewable technologies, and at last efficient use of non-renewable resources.

4) Design support Methods/Tools

The design support tools are typically used in the early stages of the design to get an idea of what approaches and design schemes are the most promising for the given project. The E-Quartet, the Eco-Façade, and the LEHVE tools fall into this group.

5) Simulation Tools

Computer simulation tools are used to predict the performance of a specific design solution.

There are no sharp borders between the different types of tools. The design support tools may in some case also be used as design evaluation tools, and vice versa. The available computer simulation tools for predicting energy use and indoor climate are typically used as design evaluation tools, but may also be used as design support tools. In fact, in order to succeed in creating effective integrated building concept, it is very useful to apply advanced computer simulation tools in the early design stages.

The Integrated Design Process by IEA Task 23

Description of method

A method called the Integrated Design Process has been developed within the framework of IEA Task 23: Optimization of Solar Energy Use in Large Buildings (<http://www.iea-shc.org/task23/>). The approach is based on the well-proven observation that changes and improvements in the design process are relatively easy to make at the beginning of the process, but become increasingly difficult and disruptive as the process unfolds. Changes or improvements to a building design when foundations are being poured, or even contract documents are in the process of being prepared, are likely to be very costly, extremely disruptive to the process, and are also likely to result in only modest gains in performance. In fact, this observation is applicable to a large number of processes beyond the building sector.

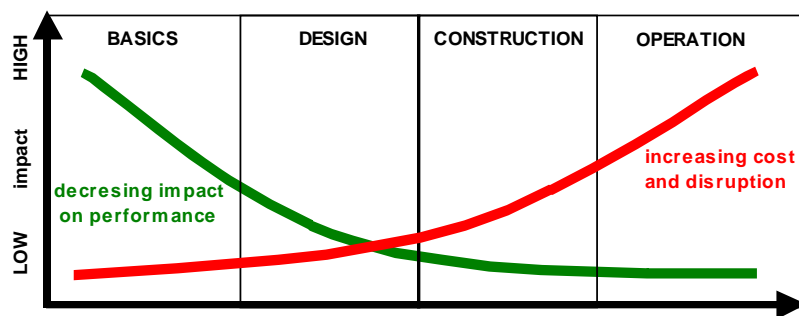

Diagram by Solidar, Berlin Germany

Although these observations are hardly novel, it is a fact that most clients and designers have not followed up on their implications. The methods and tools developed in Task 23 represent the first international attempt to build on these facts and to develop a formalized process that will enable a large number of clients and designers to take advantage of them. The Integrated Design Process includes some typical elements that are related to integration:

- Inter-disciplinary work between architects, engineers, costing specialists, operations people, and other relevant actors right from the beginning of the design process;
- Discussion of the relative importance of various performance issues and the establishment of a consensus on this matter between client and designers;
- Budget restrictions applied at the whole-building level, with no strict separation of budgets for individual building systems, such as HVAC or the building structure. (This reflects the experience that extra expenditures for one system, e.g. for solar shading devices, may reduce costs in other systems, e.g. capital and operating costs for a cooling system.)
- The addition of a specialist in the field of energy, comfort, or sustainability;
- The testing of various design assumptions through the use of energy simulations throughout the process, to provide relatively objective information on this key aspect of performance;
- The addition of subject specialists (e.g. for daylighting, thermal storage etc.) for short consultations with the design team;
- A clear articulation of performance targets and strategies, to be updated throughout the process by the design team;

- In some cases, a Design Facilitator may be added to the team, to raise performance issues throughout the process and to bring specialized knowledge to the table.

Based on experience in Europe and North America, the overall characteristic of an Integrated Design Process is the fact that it consists of a series of design loops per stage of the design process, separated by transitions with decisions about milestones. In each of the design loops the design team members relevant for that stage participate in the process.

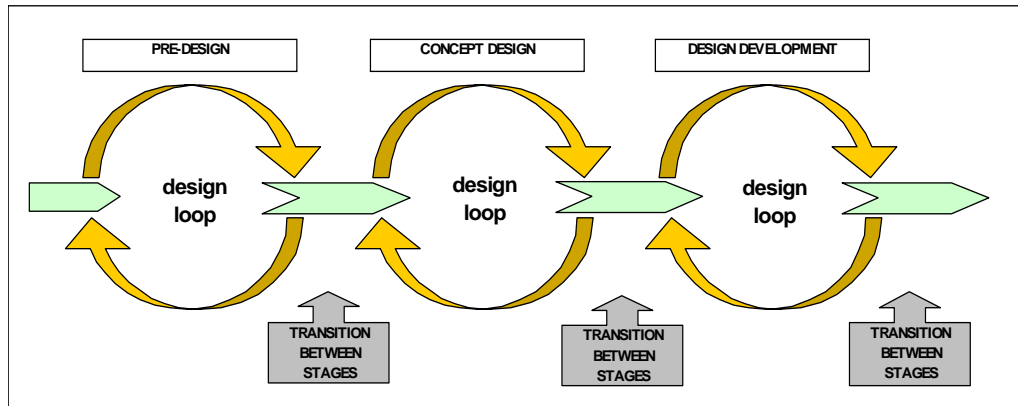
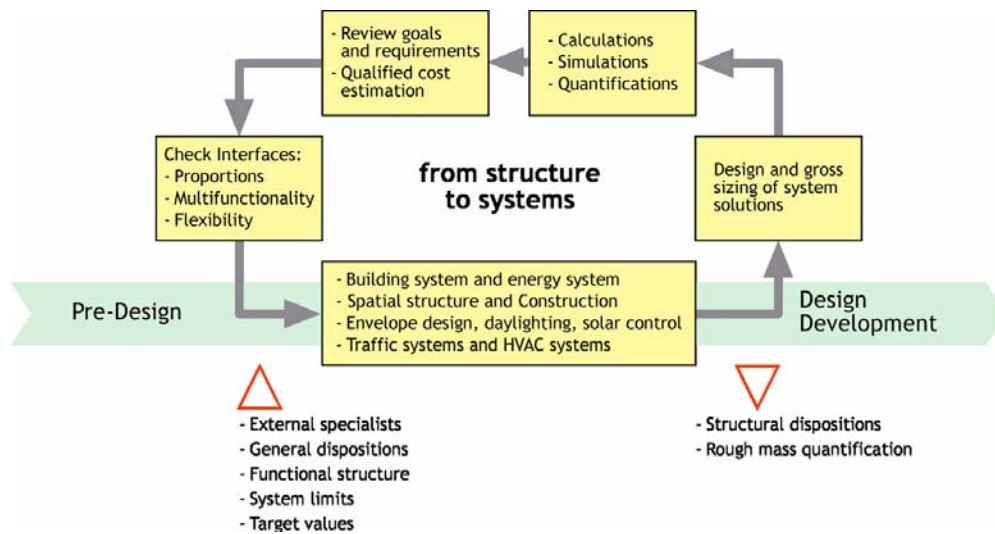

Diagram by Solidar, Berlin Germany

The design process itself emphasizes the following sequence:

1. First establish performance targets for a broad range of parameters, and develop preliminary strategies to achieve these targets. This sounds obvious, but in the context of an integrated design team approach it can bring engineering skills and perspectives to bear at the concept design stage, thereby helping the owner and architect to avoid becoming committed to a sub-optimal design solution;
2. Then minimize heating and cooling loads and maximize daylighting potential through orientation, building configuration, an efficient building envelope, and careful consideration of amount, type, and location of fenestration;
3. Meet these loads through the maximum use of solar and other renewable technologies and the use of efficient HVAC systems, while maintaining performance targets for indoor air quality, thermal comfort, illumination levels and quality, and noise control;
4. Iterate the process to produce at least two, and preferably three, concept design alternatives, using energy simulations as a test of progress, and then select the most promising of these for further development.

As an example a more detailed description of the design loop during the concept design phase is pictured. The central issue in this phase is to define systems in a conceptual way, based on the structure/scheme of the building. In a loop several options are considered, paying attention to the integration in the building as a whole, not just restricted to the technical aspects.



The Integrated Design Process in the Concept Design Phase. Diagram by Solidar, Berlin Germany.

Application of method

The need for the guidelines, methods, and tools that were to be developed by Task 23 was defined on the basis of experiences in a number of building projects characterized by a type of design process that was meant to facilitate integration. One of the projects studied is the Bentall Crestwood 8 Building in Richmond in British Columbia, Canada. Two office buildings were realized, alike in look and with comparable building cost. Yet one of them is about 30% more energy efficient than the other, and the amount of waste during construction was reduced by 50%. Compared to conventional buildings the energy use was even reduced by 50%. The building met the strict sustainability requirements from the C-2000 programme. In order to achieve these results an interdisciplinary design team worked together right from the beginning of the design process. A design process facilitator supported the design team. This approach proved to be very successful.



The Bentall Crestwood 8 Building (Photo by Bunting Coady Architects)

Towards the end of Task 23, some of the guidelines, methods, and tools developed were applied in demonstration projects with the focus on the Integrated Design Process. They illustrate the benefits of an Integrated Design Process and provide insights into some of the key issues it involves.

The first demonstration project completed was a Community Centre for the Municipality of Kolding in Denmark. The objective of this project was to create an overall solution for future

buildings for all age groups and social strata. Furthermore, the goal was to optimize the building in terms of resource use, functionality, and ecology. An Integrated Design Process was considered the most appropriate approach. In the competition phase a brainstorm workshop was organized among the architects and engineers in order to discuss and evaluate specific topics of integration. During the design process the Task 23 multi criteria decision making method was used to help identify the objectives, to sort out poor solutions, and to document the design. Passive and active solar energy technologies are applied in the building, together with other sustainable features.



The Community Centre in Kolding (Photograph by Municipality of Kolding)

The efficiency of the process was a positive outcome of the Integrated Design Process. The client considered that the resulting good indoor climate and reduced energy operating cost were a direct result of using the Integrated Design Process. The client is in general very satisfied, and the team members intend to use the Integrated Design Process in future projects.

The Integrated Design Process has impacts on the design team that differentiates it from a conventional design process in several respects. The client takes a more active role than usual, the architect becomes a team leader rather than the sole form-giver, and the mechanical and electrical engineers take on active roles at early design stages. The team should always include an energy specialist, and in some cases, an independent Design Facilitator.

Benefits

Task 23 has shown that there are significant advantages in using Integrated Design Processes. Integration on the level of the process results in synergies at both the systems level and the whole-building level:

- Early discussion of the functional program and the project goals with the client, architect, and engineers may identify anomalies and ambiguities, and rapid clarification of this will lead to subsequent improvements in the functionality of the building;
- Careful orientation, massing, fenestration, and the design of shading devices can reduce heating and cooling loads, and will often improve thermal comfort;
- A high-performance building envelope will greatly reduce unwanted heat losses or gains, often to the point where heating or cooling systems are not required to operate at the perimeter of the building, resulting in capital cost savings and a gain in usable space;

- An emphasis on daylighting will reduce cooling loads, because of reduced lighting requirements, and may also improve illumination quality;
- These factors will permit a reduction in floor-to-floor heights (or improved daylighting because of higher net floor height), and will also permit a reduction in HVAC plant and system capacity and size requirements. Significant load reductions also open the way for use of alternative and simpler systems, such as radiant heating and cooling and natural or hybrid ventilation;
- Reductions in boiler, chiller, AHU, and ducting sizes will, in turn, reduce capital, operating, maintenance, and replacement costs;
- A deeper understanding of the nature and inter-relationships of all the issues described above, will lead to the possibility of a higher level of architectural expression.

Barriers

- Extra time and resources are needed in the early design stage.
- The different members of the design team needs to have an understanding and of the integration aspects. This requires that they have some knowledge/understanding of the whole range of professional fields.

Need for further research

- Developments of design tools that facilitates and Integrated Design Process

References

Larsson, N. and B. Poel (2003) “Solar Low Energy Buildings and the Integrated Design Process – An Introduction”, <http://www.iea-shc.org/task23/>.

The Integrated Design Process (IDP) by Knudstrup

Description of method

The idea behind the development of the Integrated design process IDP methodology by Knudstrup [Knudstrup 2000, 2002, 2003, 2004] was to focus upon the ability to integrate knowledge from engineering and architecture in order to solve the often very complicated problems connected to the environmental design of buildings. The Integrated Design Process IDP enables the designer to control the many parameters that must be considered and integrated, when creating more holistic sustainable architecture, in order to achieve better sustainable solutions, where all the different parameters are considered during the process.

The method is coping with technical and aesthetical problems, and focuses on the creative element, in order to identify new opportunities and make innovative solutions in a new building design. Therefore the artistic approach, the creation of ideas, and an ability to see new possibilities and to be creative become a very important part of the process designing architecture.

The process is conducted as an integrated process by using the method, the Integrated Design Process IDP, the professional knowledge of architecture and parameters from engineering is integrated and optimised. The method is developed to the specialisation in Architecture at Aalborg University's Civil Engineer Education in Architecture & Design, Aalborg University by Knudstrup.

The integrated design process works with the architecture, the design, functional aspects, energy consumption, indoor environment, technology, and construction [Knudstrup 2003, 2004]. In the following section the various phases of a design project, will be described to give an insight into the phases of the Integrated Design Process.

In the following the various project phases will be described in details to give an insight into these phases and into the Integrated Design Process as a method. The figure below shows the design process map. The process is, in fact, a much more complex mental process, so this map is a simplification of the design process. However it illustrates the various phases and the main loops connected to the process. It is also very important to be aware that the process is an iterative process.

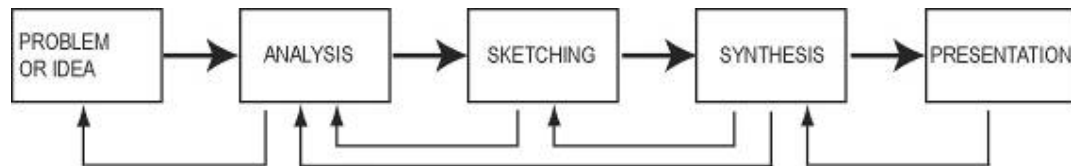

The Phases in the design integrated design process

Problem formulation or project idea. The first step of the building project is the description of the problem or the project idea to an environmental or sustainable building.

The Analysis Phase encompass an analysis of all the information that has to be procured before the designer of the building is ready to begin the sketching process, e.g. information about the site, the architecture of the neighbourhood, topography, vegetation, sun, light and shadow, predominant wind direction, access to and size of the area and neighbouring buildings. The designer has to consider demands coming from regional plans, municipality

plans and local plans. Furthermore, it is important to be aware of special qualities of the area and the sense of the place; *genius loci*.

Through the analysis phase detailed information is procured about the user's demands for space, discussed etc. The architecture demands and a chart of functions and a company concept which can lend inspiration to the design of the building. It is also here decided if the new building is going to have an iconic character at the site or in the urban landscape. Here it is also very important to decide principles for especially targets for energy use (heating, cooling, ventilation, lighting) and indoor environmental quality (thermal, comfort, air quality, acoustics, lighting quality) of the new building as well as criteria for application of passive technologies (natural ventilation, day lighting, passive heating, passive cooling). These criteria should be developed considering the local climatic conditions and the local energy distribution facilities. At the end of the analysis phase a statement of aims and a programme for the building is set up including a list of design criteria, target values.

The Sketching Phase is the phase where the professional knowledge of architects and engineers is combined and provide mutual inspiration in the Integrated Design Process, so that the demands and wishes for the building are met. This also applies to the demands for architecture, design, working environment and visual impact, and the demands for functions, construction, energy consumption and indoor environmental conditions. During the sketching phase all defined criteria and target values are considered in the development and evaluation of design solutions. As well as demands for logistics and other demands, which are described in the room programme.

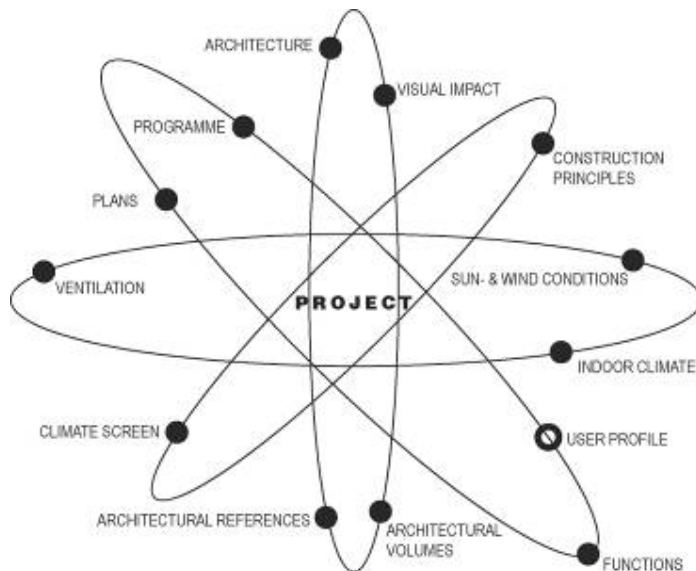

The various parameters that are interacting in the Integrated Design Process

As mentioned above, in this phase the professional parameters from architecture and engineering are flowing together in the Integrated Design Process in interaction with each other. The precondition for designing an energy saving building in an Integrated Design Process is as follows: In the sketching phase the designer must repeatedly make an estimate of how his or her choices regarding the form of the building, the plans, the room programme, the

orientation of the building, the construction and the climate screen influence the energy consumption of the building in terms of heating, cooling, ventilation and daylight – and how these choices inspire each other. The mutual influence and inspiration of all the above parameters must meet the demands which have been set up for the architectural, functional and technical aspects of the building.

Typically the different solutions have different strength and weaknesses when the fulfilment of the different design criteria and target values is evaluated. In this phase the designer is making a lot of sketches to solve the various problems in order to optimise the final and best solution that hopefully will appear in the next closely connected phase, the synthesis phase.

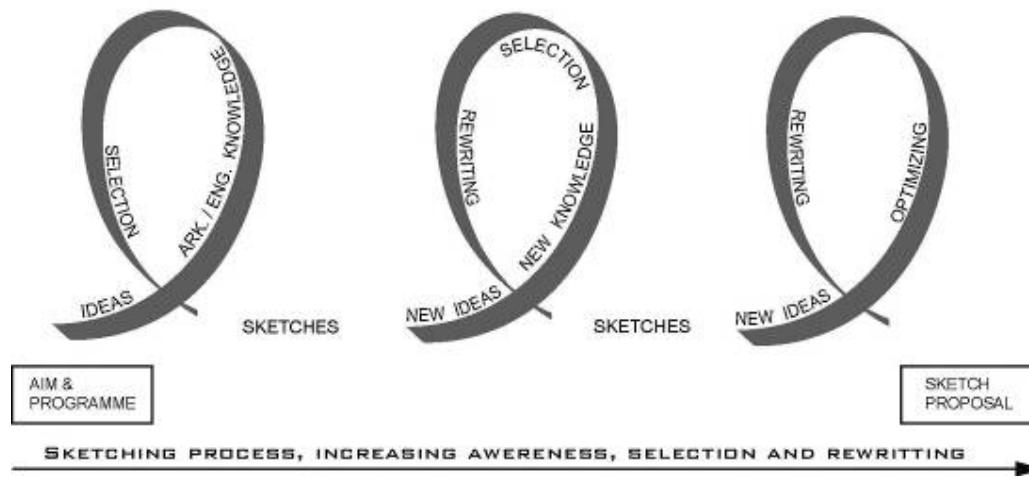

The sketching process is repeated several times. S. Agger [1983] inspires to this illustration.

The Synthesis Phase is the phase where the new building finds its final form, and where the demands in the aims and programme are met. Here the designer reaches a point in the design process where all parameters considered in the sketching phase flow together or interact – architecture, plans, the visual impact, functionality, company profile, aesthetics, the space design, working environment, room programme, principles of construction, energy solutions and targets and indoor environment technology form a synthesis. In the synthesis phase the various elements used in the project should be optimised, and the building performance is documented by detailed calculation models.

In this way the project reaches a phase where every item, one might say “falls into place”, and other possible qualities may even be added. The project finds its final form and expression, and a new building with – hopefully good – architecture, architectural volumes, aesthetic, and visual impacts, functional and technical solutions and qualities have been created.

The Presentation Phase is the final phase, which includes the presentation of the project. The project is presented in such a way that all qualities are shown and it is clearly pointed out how the aims, design criteria and target values of the project have been fulfilled for the new building owner. The presentation to the client will consist of a report a cardboard model and IT-visualisation.

Application of method

The IDP can be used for environmental or sustainable projects. But there is still a need more specific methods, e.g. related to a particular function in a specified climate. By looking at the development of methods in environmental and sustainable architecture in general one can conclude that others have reached the similar conclusions that methods in sustainable architecture are important, as most methods focus on subsections of sustainable design. These are important but a more holistic method is also needed which embraces all the subsections and completes the sustainability of architecture.

The IDP enables the designer to control the many parameters that must be considered and integrated in the project when creating more holistic sustainable architecture in order to achieve better sustainable solutions, because all the different parameters are considered already from the annals phase and during the process.

The method is first of all used at the master level of the Architecture curriculum when the students produce energy and climate optimised buildings. The objective is described in the study guide for the semester [Knudstrup 2000, 2002]. The approach by developing the methodology, Knudstrup drew upon here professional education and background as an architect as well as methods used entrenched as an active or passive knowledge in here profession [Lawson 2000] as well as knowledge about technical parameters from engineering.

IDP is based on group work, but it can also be done by traditionally educated architects and engineers as well. If the method is used in practice it would be easier to overcome the many aspects in a team consisting of people with different competencies, especially if it is a larger project and if they are not educated in the Integrated Design Process IDP, because of the many parameters and the trans-disciplinary approach.

Benefits

The students' project shows, that it is possible to integrate the engineer skills with the architect skills in the projects, and they are learning a method, which enable them to combine other parameters than the traditional architect parameters in the process.

The students are, in fact, creating very interesting buildings with high qualities, where the architecture language is integrated with and inspired by engineering parameters, so that the architectural and technical solutions are optimised. The point is that the students have to integrate the engineer parameters from the very beginning, already in the analysis phase, and further in the process when the sketching of the building is taking place, so that they can make a synthesis of the architectural and engineering parameters.

- If the indoor environmental conditions and the energy frame of the building become clarified, we in this way can avoid frustrating problems when e.g. ventilation does not fit into the design of the building.
- From an economic point of view, the operating costs can be kept at a low level when the climate shield of the building is optimised saving energy for cooling and heating, and the passive ventilation principles are employed, which also reduces energy expenses.
- There is no tradition talking the same language so architects and engineers sometimes come from “different planets”. The architect belongs to a humanistic tradition where as the engineer belongs to a positivistic tradition. This creates problems when working as a team, as the communication between the different parties relies on a common language and in this case the languages are very different.

Need for future research

- The more parameters you integrate the more time pressure you got, that's a problem! So which is the most important?
- The designers have to take good care of the architectural demands and qualities in the project so it will not disappear in all the technical calculations.
- Interdisciplinary research between architecture and engineering should be encouraged.
- I see it also as a huge challenge to develop programmes which can be used for co-optimising a wide number of parameters at the sketching level - both architectural parameters (design, climate shield, facades, plans arrangements, functions, logistics, materials) and engineering parameters (natural ventilation, climate shield, needs for heating and cooling, and construction).
- How can we implement this method to mainstream architects or designers?

References

Steen Agger (1983), "Compendium for course in programming and sketching methods", School of Architecture in Aarhus. Denmark.

Knudstrup Mary-Ann (2004), "Integrated Design Process in PBL", article in The Aalborg PBL model red. Anette Kolmoes, Flemming K Fink and Lone Krogh. Aalborg University Press 2004. Denmark.

Knudstrup Mary-Ann (January 2000 & 2002), "Study guide for 6th semester, Architecture. Architecture and Ecology – Energy and environment in Architecture", Department of Architecture & Design, Aalborg University. Denmark.

Lawson, Bryan (2000), "How Designers Think. The design process demystified", Architectural Press, UK.

Integrated Building Design System (IBDS)

Description of method

A method called Integrated Building Design System (IBDS) has been developed at Cambridge Architectural Research Limited and The Martin Centre for Architectural and Urban Studies, Department of Architecture, University of Cambridge by Koen Steemers. The approach to the integrated building design system, the IBDS methodology provides a flexible system for assessing the interrelationships and levels of integration of design parameters for low energy design in an urban context. The method is flexible in that additional and alternative parameters can be included in the analysis. Thus if the emphasis of a project shifts to include for example interior planning issues (such as interior finishes, visual and thermal comfort, etc.) or wider urban issues (such as the microclimate, transport, green space, etc.) these can be incorporated by the design team in the IBDS method. However, the variables presented here are considered to be the primary ones.

This is the methodology for an integrated building design system (IBDS) in an urban context. It sets out to provide a framework of working which demonstrates and reminds the design team of the range of issues and interactions through the design process. It should not be considered as a rigid process but rather as a way of raising awareness of the integration implications of a range of environmental and design parameters.

The IBDS proposed here can be broken down into four main sections as follows:

1. Principles of low energy design
2. Pre-design context
3. Building design
4. Building services

1. Principles of low energy design

This part of the IBDS considers the roles of the key environmental design principles and the associated building physics that will impact on the design. The focus here is on those factors that determine the energy performance of the building form and fabric, and the related comfort issues, and thus includes:

- Passive solar design
- Daylighting
- Natural ventilation
- Comfort

This brief list is by no means exclusive and additional or alternative aspects could be included that are of particular relevance to the project in hand. However, it is proposed that the above factors are central in the context of energy efficient urban design.

Each aspect – which can be further broken down into sub categories – will have an impact on strategies adopted for the building design and services, and provides the necessary principles upon which to base decisions. The purpose of including these principles is that they are central to explaining the physical mechanisms that link design decisions with performance consequences.

2. Pre-design context

Any project will have a number of pre-determined design constraints. These are determined by the site, the client and the planning authorities and thus include the following:

- Site climate and context
- The building brief
- Local building and planning regulations

Again, additional pre-design aspects could be included if this is desired. Each of the above key factors will have a significant impact on the design from the outset and are largely fixed, although some manipulation and negotiation is occasionally possible under each category. Thus for example, the urban context is largely a given, but changes to the site boundary may be negotiated. Similarly the client may change the building brief as a result of site analysis, and some negotiation may be possible with planning authorities to obtain exemption from certain regulations.

3. Building design

At the core of the IBDS lie the building design considerations. The primary parameters can broadly be defined as follows:

- Urban planning
- Building form
- Façade design
- Building fabric

Not only will these variables be influenced by the ‘Principles’ and ‘Pre-design’ issues already outlined but there will be strong interdependencies within this group of design concerns. For example, the building form – whether terraced or courtyard or deep plan, etc. – will impact on the overall layout, but will also influence the decisions related to the façade design and building fabric. These considerations will furthermore have a bearing on the appropriate choice of building services, outlined below.

4. Building services

The above sections on ‘Building design’ and ‘Principles of low energy design’ focus primarily on the passive design strategies. However, in any given context it is more than likely that buildings will need to rely to a certain extent on mechanical systems to ensure comfort conditions are maintained. Here we consider such systems as auxiliary – i.e. the aim is to minimise reliance on them and thus reduce the energy demand. The following four categories are considered:

- Heating
- Cooling
- Mechanical ventilation
- Artificial lighting

It is clear that ‘Building design’ decisions should determine the appropriate ‘Building services’ strategies. At a simple level: if a deep plan is adopted then increased mechanical ventilation – possibly even cooling – as well as artificial lighting is necessary. This may be offset against reduced solar gains or heat loss, and requires the ‘Principles of low energy design’ to be rigorously applied.

The aim of IBDS methodology is to demonstrate how the various factors described above interact and – more importantly – how they can be integrated successfully and holistically to achieve low energy urban building design.

Clearly, design is an iterative process and the strategy outlined here should not be considered as a simplistic linear process. The main purpose is to increase an awareness and understanding of interrelationships that exist in the design process. It can be used as a framework for design team discussions at the various key design stages, as well as a design tool at any given stage (be it outline design or construction detailing). The system inevitably needs to be sufficiently general to enable local conditions, expertise and individual procedures to be incorporated, and should not be used in a deterministic manner or in isolation.

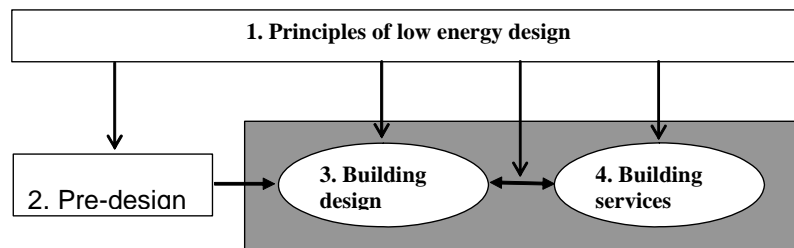

Schematic layout of overall IDBS stages and relationships

The figure provides a simple overview of the structure. The highlighted (grey) area is the building-related procedure, which will be the focus of the IDBS. The following schematics will address first ‘building design’ issues – broken done into a number of sub-categories – and the relationships to other design parameters and to low energy principles issues. And this is followed by a schematic of” building services” issues in a similar manner. Finally the method shows, an overall matrix of all the key parameters to demonstrate the integrated interrelationships between each.

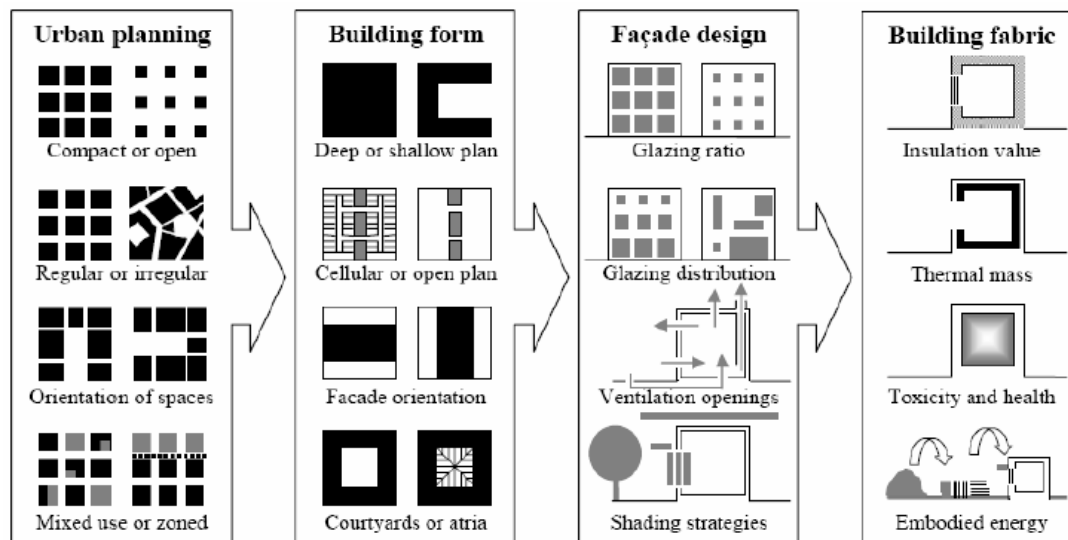

Schematic layout of building design related issues depicted the primary sub-categories of each main design consideration.

Design parameters v. energy strategies

The method shows how one can combine the design variables with both the passive and active energy strategies and then it becomes possible to rank the strength of interrelationships.

The method lists the various parameters and here one can see whether the parameters are design related or energy related, according to the frequency of interrelationships between each category. This methodology can be applied to any key set of parameters as set by the design team. For this matrix, at the top of the design list, in terms of the variables that have the greatest links and implications for energy and services strategies are the following:

- Deep or shallow plan
- Cellular or open plan
- Ventilation design
- Courts or atria
- Orientation

The primary environmental issues are as follows:

- The need for air conditioning v. natural ventilation
- Mechanical versus natural ventilation
- Solar gains
- Daylight
- Distribution of solar gains

Application of method

It is proposed here to argue that for the successful performance of buildings it is essential to consider all the aspects that impact on energy use – from planning to detailed materials specifications. The integrated design implies and requires an understanding of the relative impacts of each parameter – both those determined by design and those that can be described as technical – to achieve a balanced and holistic strategy.

One strategic aim of the integrated approach is to avoid conflicts between the architecture and technology. This requires a close collaboration between architect and engineer from the beginning of the design process. This is contrary to the common approach where an architect designs a building first and then an engineer is expected to make it work through the application of services (and the use of energy to ‘correct’ poor design decisions). If the energy considerations are not integral to the design solution it becomes difficult to improve the energy saving potential through the application of technology alone. Thus, if a design does not integrate natural ventilation strategies for example, then more energy-intensive mechanical systems may be the only recourse without fundamentally changing the building design.

Benefits

At a most fundamental level, an example of integrated design is one in which the use of passive strategies is exploited to reduce the reliance on conventional mechanical services. Thus, for example, shading devices reduce the reliance on mechanical cooling, or natural lighting strategies can limit the need for artificial lighting energy demand.

Barriers

It has been argued that design integration is critical, and that the means to achieve it is through the early and effective collaboration of the design team.

References

Koen Steemers at Cambridge Architectural Research Limited and the Martin Centre for Architectural and Urban Studies. Department of Architecture, University of Cambridge. 2005.

Eco-Factor Method

Description of method

A guideline tool for an integrated design approach has been developed within an EU-project called IDEEB (Intelligently Designed Energy Efficient Buildings) during 2002-2004. The concept is thoroughly described in Bjørn et al. (2004) and Brohus et al. (2004), and summarized in Wahlström and Brohus (2005).

The projects “motto” was that the whole energy system, regarding both the building and the technical installations, must be considered in order to achieve energy efficient buildings with good indoor comfort and low environmental impact. This requires an integrated design approach of all building elements with involvement of all disciplines. Since each building is unique there are no all-encompassing solutions, and therefore the guidelines aims to describe the way of working to reach the goal.

The assessment concept is using the Eco-factor method for assessment of different building designs and thereby avoid unforeseen dangers of compromising indoor climate in order to improve the energy performance, or vice versa. However, the concept can be extended with other assessments, for example of the buildings function at integration of building elements.

The concept works on two levels. The first and most “simple” level, the *concept design level*, is applied to get a fast overview and intelligent suggestions of alternative building designs. This level will consist of guidance for scanning, coarse methods, principles, catalogues etc, that will help to give intelligently design suggestions of the building without doing any detailed simulations. The suggestions are sketches/scenarios of the building design.

This pre design level consists of parameter studies for net heating and cooling use during one year for a reference building. Parameter studies for indoor climate where different cases are studied, day-night, winter-summer etc. Also different cooling (heating) techniques will be studied as free cooling, district cooling, cooled ceilings etc. Input from these parameter studies will together with installation energy effectiveness and choice of energy sources give an estimation of the Eco-factor. The results give guidance of how different parameters affect the indoor climate, the energy consumption and the Eco-factor for a reference case.

The second and “advanced” level, the *detailed design level*, is aimed for the consultants to do detailed designs of a few chosen cases. This is a method on how to systematically explain how to do advanced simulations, and suggestions of simulation tools to use.

Each level consists of two phases, a *design phase and an assessment phase*. In the pre design phase is the building designed by two or three sketches going into more detail on a chosen overall solution in the advanced design phase. These building suggestions are assessed according to the Eco-factor method. Apart from architectural, technical and environmental issues, economic planning must always be made in parallel, meaning that life cycle costs must be calculated as part of the design process.

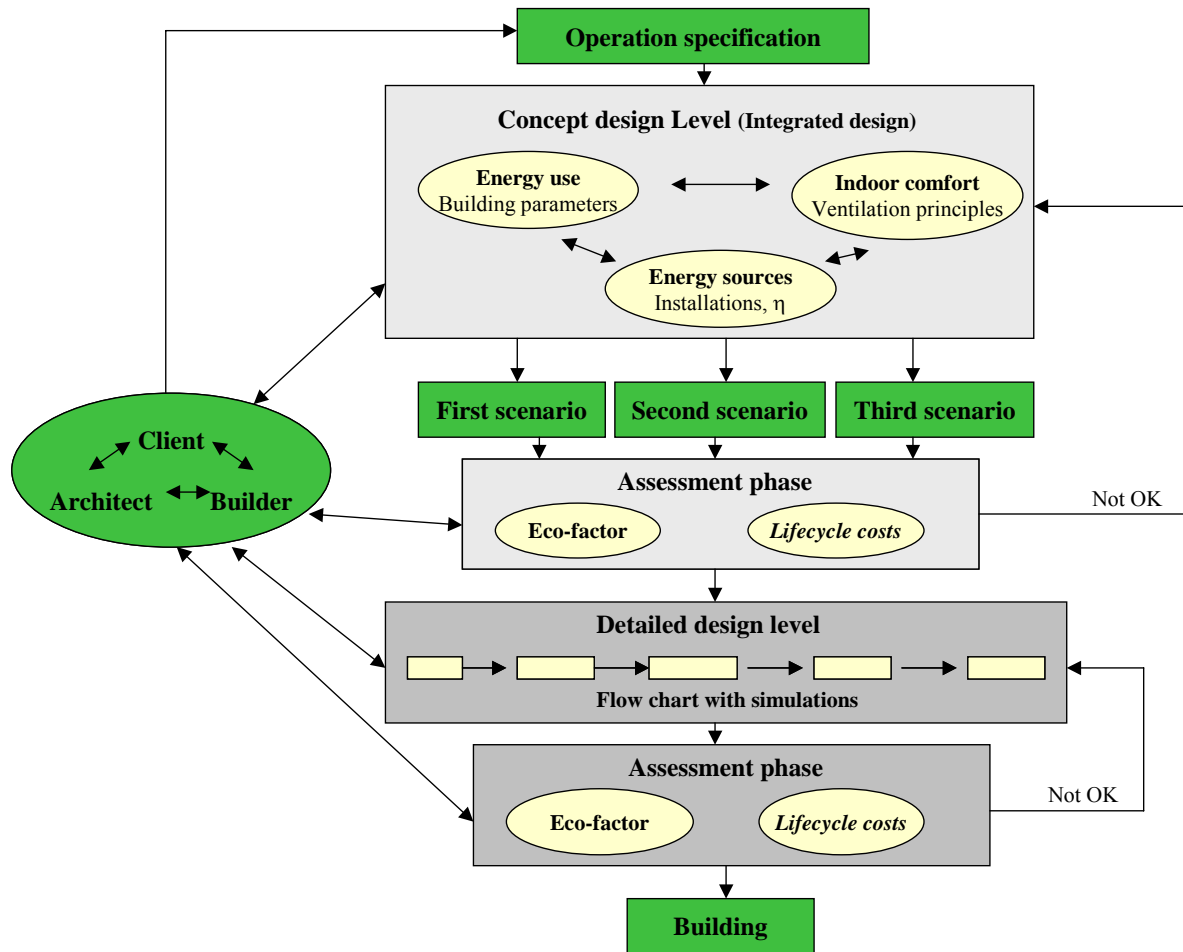

Illustration of the assessment concept.

If the suggested building design and technical solution give satisfactory results in the assessment phase, the concept will lead to the next level. If not, the process will go back to the design phase. This process will continue in an iterative way until a desirable Eco-factor is achieved for a suggestion with reasonable costs.

The Eco-factor aims to assist by providing a simplified and standardised output the overall environmental performance to decision-maker (e.g. the owner or the architect), who can then better concentrate on taking the best decision, instead of wasting valuable effort on understanding and evaluating technical details.

Determination of the Eco-factor requires input data from two core environmental impact categories, which in any case, will be calculated or otherwise assessed as part of the building design process. The building designers have different needs at different stages of the design process and therefore will the level of detail of these input data increase with the stage of the iterative design process. The input data can be calculated by using different energy and indoor climate simulation tools but can also be calculated by the same calculation tools, since they require the same underlying theoretical models.

For this reason the Eco-factor method is defined so input can be based on both simple and advanced calculations in early and later phases of design, respectively, while still delivering the same output, see the figure below.

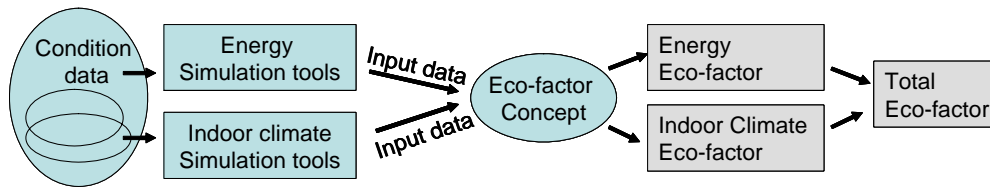

Calculation of the Eco-factor requires input data from existing energy and indoor climate simulation tools. The required quality and detail of the energy and/or indoor climate simulation tools increases as the design progresses, while the Eco-factor method remains the same.

The Eco-factor illustrates the impact of two core issues:

- Global environmental impacts
 - Energy use from different energy sources during operation
 - Emissions to the atmosphere during the life cycle of the energy source
- Indoor environment
 - Thermal comfort
 - Atmospheric comfort, IAQ

The method consists of an index system based on indicators of physical properties (namely operational energy use, air-borne emissions, plus indoor temperature, velocity, and concentration fields) and weighting factors from the literature that describes the environmental impact and the indoor comfort in a score on a common "scale" from 0-100%, called the "Eco-factor". A high score indicates that the building has a good indoor climate, low environmental impact or use renewable energy sources, or a combination of these factors.

The outdoor environmental impact part is based on emissions from operational energy use of different energy sources. All emissions during the energy sources' complete life cycle are considered "from cradle to grave". The indoor climate part considers aspects that are closely interrelated with energy use, thermal comfort and indoor air quality.

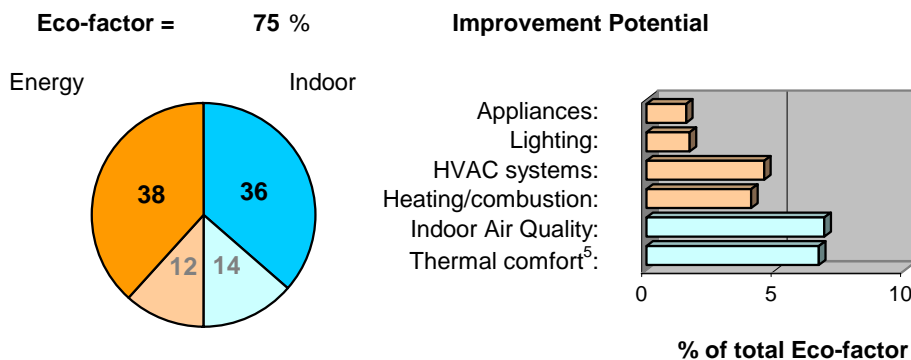

Example of how the result of the Eco-factor is illustrated. On the right side is an illustration of the "Improvement potential", which shows the specific parts of the design that are not performing well or where you can achieve more "points" to improve the Eco-factor.

To be of any practical use, the Eco-factor must be able, relatively quickly, to provide a visual and easily understandable representation of the environmental effects of different alternative choices. The Eco-factor tool, which is Excel-spreadsheet based, has therefore been created

with a database of “default” data. The tool assists with default data of eco-profiles of typical energy sources and weighting factors for different assessment methods and the user will not need to supply these input.

Application

The assessment concept is intended to be an integral part of new design guidelines where architects and engineers should be able to obtain a quick overview of the effect of changing key parameters such as room height, air change rate, internal heat loads, control strategies, etc. in rapid iterations, showing the potential for improvements in energy-related emissions and indoor climate. The improvement potential is visualized by the Eco-factor method which aims to assist the architects and engineers to easy communication with the client.

The assessment concept should be possible to use with different contracts/organizations but require a close cooperation between different parties in different stages of the process (Nordström, 2004). The important part in the assessment concept is the recurrent “assessment phase”, there the architect and project-leader discuss different solutions with the client. Here different energy solutions are assessed with its influence of the total building performance. This should prevent that single issues in the design will be changed without evaluation of how it will affect the total performance. The Eco-factor method aims to present the evaluation in an easy visible interpretation of the result.

During development the guideline has been tested theoretically in case studies of newly built energy efficient buildings (Bjørn and Brohus, 2003). It has also been tested in pre-design of a new construction in Gothenburg and a retrofit of an office building in Bristol. Unfortunately, the market situation for the construction of office buildings changed so that the constructions have not been carried out. The guideline is now ready to be tested in practice for improvements and extensions.

Benefits

The assessment concept for the building design process with the Eco-factor method has been developed considering the following requirement specification:

- The ability, relatively quickly, to provide a visual representation of the environmental effects of different alternative choices, which is easy to understand and to communicate.
- It simplifies the decision process to consider only one “scale”, instead of having to consider kWh/m², PPD, PD, DR etc. and discussing how much significance to attribute each result.
- Constant format of output, meaning the same resulting indicators are used regardless of the calculation models used for energy and indoor climate.
- Supports an iterative procedure, useful for “integrated design”.
- No advantage in focusing on single issues, since poorly performing parts of the design are penalized.
- The “ranking” method can assist the designer by highlighting potentials for improvement.
- Will reward buildings that respond to local conditions, rather than just copying other solutions. This is a result of using results-orientated indicators. Energy use, energy sources and indoor climate indicators must be calculated either on the basis of local climate or of energy sources.
- Can be used both in the design phase and for improving operation, e.g. by decisions made by the control system of the building, since indicators are measurable.

Need for further research

The guideline is developed by primarily considering design of European office buildings and should cover warm, moderate and cold European climates. With small adjustment it should be possible to use it at design of any kind of building.

The assessment concept is using an integrated approach with involvement of all disciplines. This makes the guideline very suitable for integration of responsive building elements and it is now ready to be tested in practice.

References

Erik Bjørn, Åsa Wahlström, Henrik Brohus (2004). "Eco-factor Method", Report of the EU-Energie project "IDEEB". IDEEB Report No. 02, ISBN 91-7848-974-1, *SP Swedish National Testing and Research Institute*.

Henrik Brohus, Erik Bjørn, Anker Nielsen, Åsa Wahlström (2004): "Assessment concept for the building design process", Report of the EU-Energie project "IDEEB". IDEEB Report No. 03, ISBN 91-85303-24-0, *SP Swedish National Testing and Research Institute*.

Åsa Wahlström, Henrik Brohus (2005): "An Eco-factor method for assessment of building performance", Proceeding of the 7th Symposium on Building Physics in the Nordic Countries, page 1110-1117, Reykjavik, June 13-15, 2005.

Erik Bjørn, Henrik Brohus (2003): "Case Studies - Existing Buildings". Report of the EU-Energie project "IDEEB". IDEEB Report No. 01, ISBN 91-7848-929-6, *SP Swedish National Testing and Research Institute*.

Christer Nordström (2004): "Coordination in the planning and building process". Report of the EU-Energie project "IDEEB". IDEEB Report No. 05, ISBN 91-85303-26-7, *SP Swedish National Testing and Research Institute*.

All reports are freely available on www.ideeb.org

Trias Energetica

Description of method

For an energy efficient building design a great number of choices have to be made. These choices have to do with the building, the ventilation of the building and the building services. Not only the level of performance of the various components and equipment has to be determined, but also the combination of elements has to be tuned. This is a quite complicated process and needs the involvement of an expert.

Building	Ventilation	Installations heating, cooling DHW
<ul style="list-style-type: none">• Thermal insulation<ul style="list-style-type: none">– R_c-facade, roof, floor– $U_{\text{window}}, U_{\text{glass}}$• Air tightness<ul style="list-style-type: none">– $q_{v,10}, n_{50}$• Orientation• Sun optimal• Solar shading• Thermal mass	<ul style="list-style-type: none">• Natural• Mechanical• Demand controlled• Heat recovery• Night ventilation• Openable windows	<ul style="list-style-type: none">• Gas fired boiler• High temperature<ul style="list-style-type: none">– Radiators, convectors• Low temperature<ul style="list-style-type: none">– Floor heating• Heat pump<ul style="list-style-type: none">– storage• District heating HPC• DHW• Cooling• Solar collector• Controls and metering• Buffering• Distribution

A great number of items determine the energy performance of a building

To reach the high requirements on energy savings a single technique or measure no longer suffices and in present buildings a combination of energy saving measures, the application of sustainable energy and an efficient use of fossil fuels is needed. The counter side of the increased energy efficient building has become visible in a number of bad practices. Dwellings where the energy efficient measures were chosen, purely based on energy efficiency and costs, have resulted in overheating problems during summer. The worst examples show temperatures in the bedrooms above 50°C, during periods with an outdoor temperature of approx. 30°C. These problems were not foreseen and underline the need for an integrated design approach.

Storage of energy becomes crucial in the solution for energy neutral buildings. At the moment in the Netherlands a concept with seasonal storage of energy in the ground, in combination with heat pumps and a building with a low heat- and cooling demand are commonly applied. In these concepts the various operation modes for the different seasons and the energy requirements for DHW need to be tuned into one total concept. The need to answer this complex problem has led to the development of an integrated design approach.

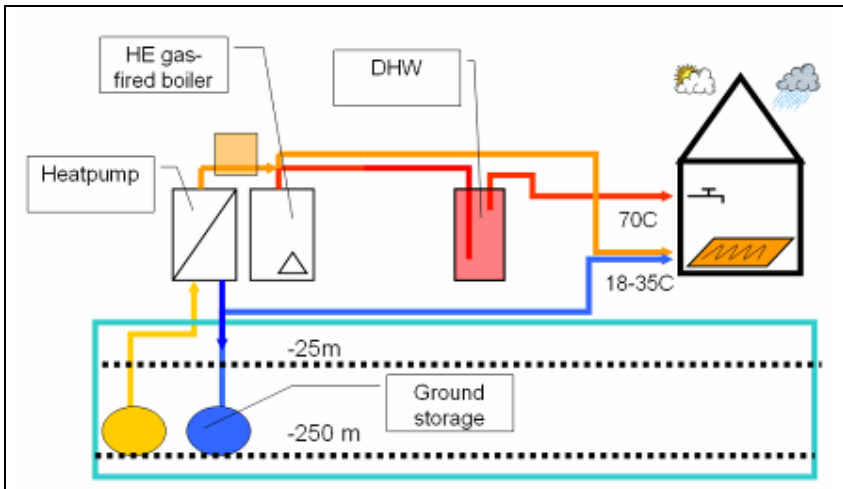

A complex energy system with long term energy storage needs an integrated design approach to tune the building, the installations and the storage system

Trias Energetica is a three step approach that gives the priorities for realising an optimal sustainable energy solution. The approach was introduced in 1996 by Novem in the Netherlands (Lysen 1996) and has been further worked out by the Technical University of Delft. The Trias Energetica method contains the following steps:

- Reduce the energy demand, by applying energy reducing measures (thermal insulation, air tightness, heat recovery)
- Use as much sustainable energy sources as possible for the generation of energy (solar, wind and biomass);
- Apply fossil fuels as efficient as possible (high efficient gas boilers, high efficient lighting)

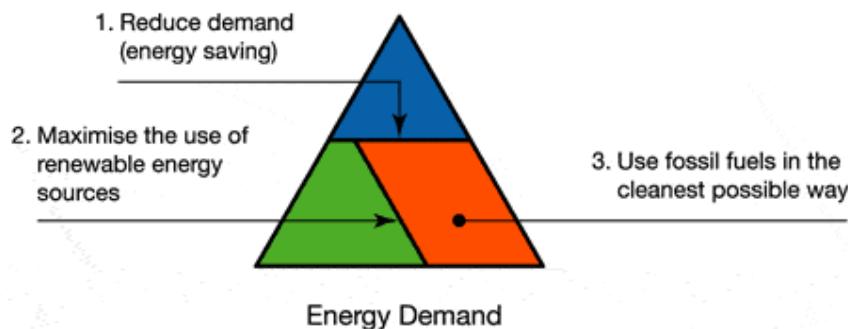

The Trias Energetica as a design approach.

Application of method

The process scheme below shows how to apply the Trias Energetica. The method is being implemented in an Excel-based toolkit by Cauberg-Huygen, Rotterdam, the Netherlands. To get an overview of the performance of the building over the whole year simulations can be carried out. These simulations give the hourly heating and cooling demand for a reference year. However, it is difficult to draw conclusions from this plot due to the erratic behaviour of the curve. By sorting the heating and cooling demand a load-duration curve arises. This curve can be very helpful by applying the Trias energetica design approach.

In the figure below the hourly simulation results are given for a large building with natural ventilation and standard quality of insulation glass (red curve). By applying a better glazing and balanced ventilation with heat recovery the total energy demand for heating reduced. Not only the installed power reduces from approx. 3300 kW to 1800 kW, but also the energy consumption decreases with more than 60% (surface under the curve). At the same time the installed power for cooling and the energy consumption for cooling increases with more than 70%. In the first step of the Trias energetica approach the goal is to reduce the heating and cooling loads as much as reasonable, based on the cost-benefit effect.

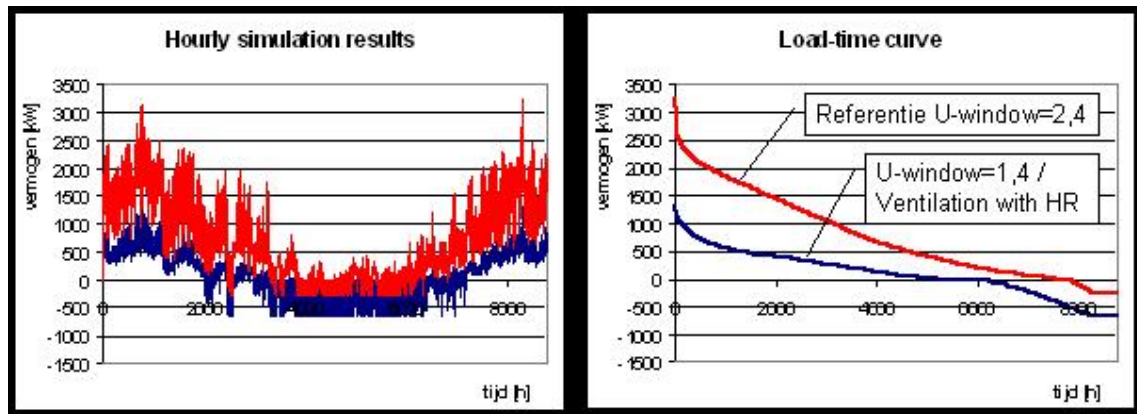

First step of the Trias Energetica approach based on hourly simulations and load duration curve.

In the next steps the installations are filled in the load-duration curve. The figure below shows the distribution of sustainable and fossil sources.

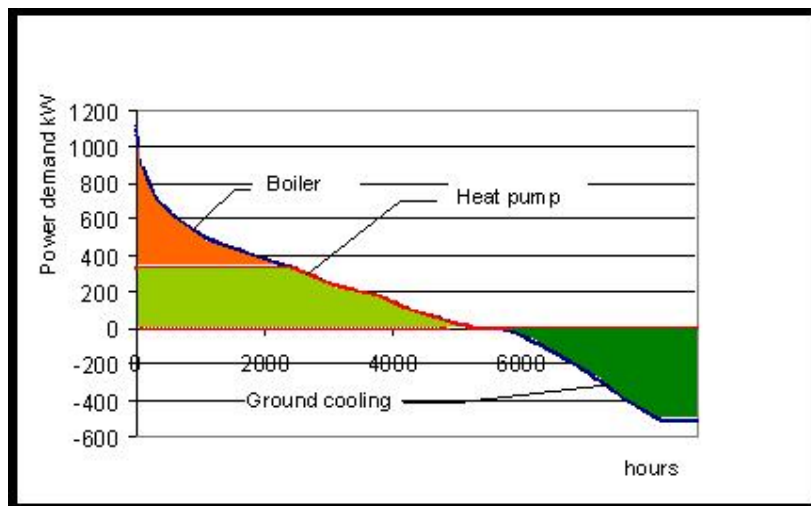

Filling in of heating and cooling installations.

The aim is to install an optimum amount of renewable sources with an optimal running performance. As most sustainable sources do not have the possibility to run at a partial load it has to be selected on power and running time. However the installation of a limited amount sustainable energy power (ie. Between 30-40%) leads to the coverage of about 80% of the energy supply, as is shown in the figure below.

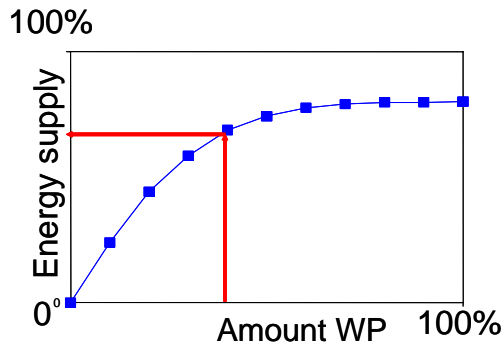

Amount of SE energy applied versus amount of energy supply

In case of energy storage an additional requirement is valid. In that case there needs to be a balance between the seasonal amount of energy that is stored and extracted over the year. This also can be derived from the load-duration curve.

There is a growing attention for building energy neutral buildings in the (near) future. For this energy neutral buildings a number of requirements have to be fulfilled. These requirements can be derived from the load-duration curve, based on the Trias energetica and lead to “ideal” load time curve.

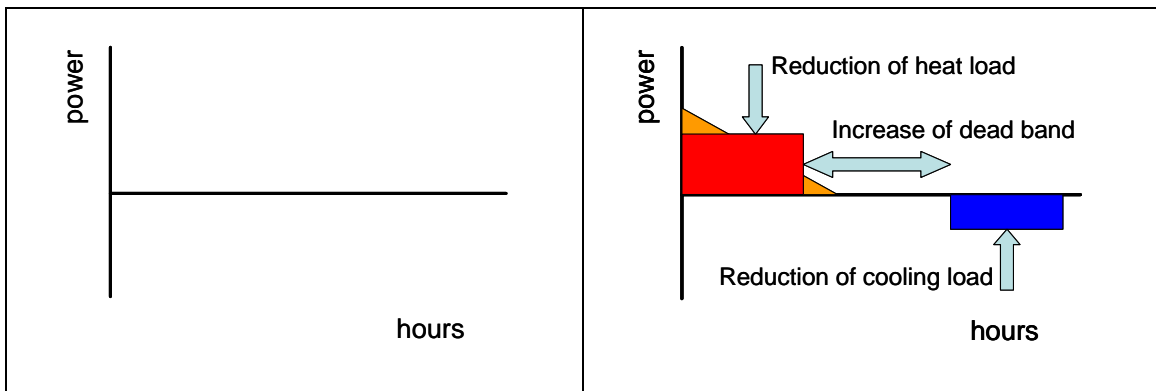

Most ideal and ideal load-duration curve

The most ideal load-duration curve has no heating load and cooling load. This however is no reality. The following design aims can be given:

- The first step of the Trias energetica needs to be filled in as much as possible by reducing the heat and cooling loads.
- An optimal load-time curve contains a minimal gradient. A strong ascending curve implements that a peak facility for heating or cooling is needed, that only for a small portion of time is being used;
- A large dead band period between the heating and cooling period is desirable;
- With seasonal energy storage there needs to be a balance between the required heating energy and cooling energy of a year.

The Trias energetica gives a 3-step design approach to come to an energy efficient design. This by optimising the design step by step and going to the next step if the cost-benefit relation is no longer in balance. From a theoretical point of view it can be argued that this cost-benefit relation can be composed from:

- The additional costs for materials, labour, transport etc
- The extra costs for installation and equipment
- The benefits in term of energy savings

In that case the Trias energetica flow chart looks as shown the figure below.

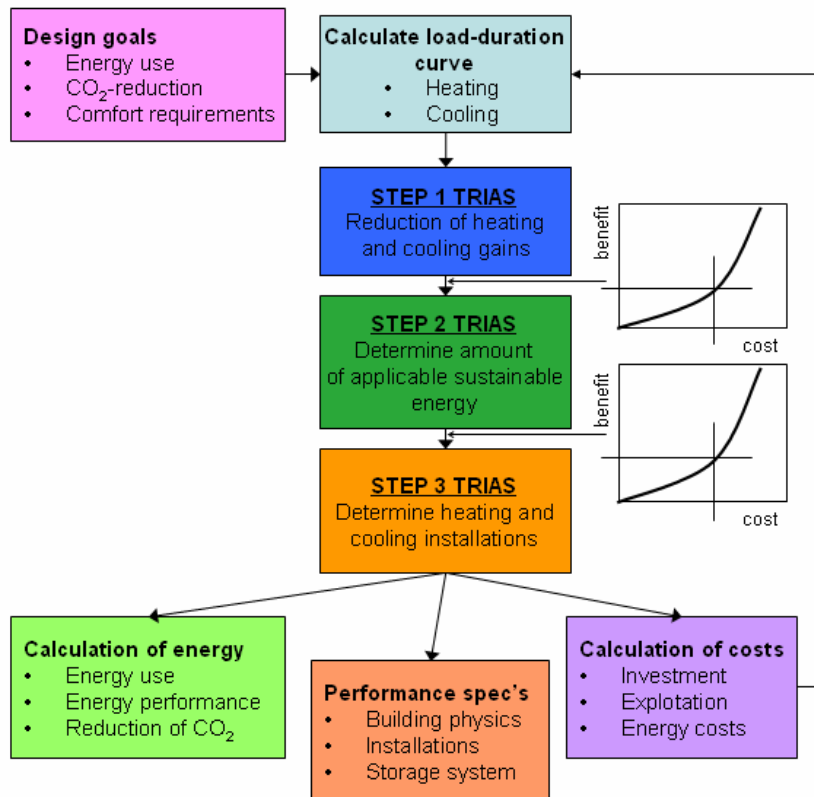

Flow chart for Trias Energetica

In practice the design steps turn out to be far more complicated. The criteria for the optimisation of a certain step are turn out to be an optimum based on cost benefit, together with:

- Building tradition and daily practice
- Contracts with suppliers
- Socio- economics aspects, interest of designers
- Willingness to change
- Organisation of the contractor
- Etc. etc.

At the moment this has for the Dutch situation led to two step design approach:

1. The STEP 2 dwellings

The STEP 2 dwellings can be described as having a fairly good thermal insulation level and air tightness in combination with an optimal energy saving installation. The characteristics of this dwelling are:

- U-value of wall, roof and floor 0,25 W/m²K
- U-value of windows 1,6 W/m²K
- Air tightness q_{v,10}=40-60 dm³/s

- HE boiler system in combination with solar collector and balanced ventilation with heat recovery or
 - Heat pump system and balanced ventilation with heat recovery
2. The STEP 1 dwellings can be described as extremely insulated and air tightness in combination with a minimum of installations. This concept is also known as the Passive house concept

The load-duration curves for both energy concepts are given in the figure below.

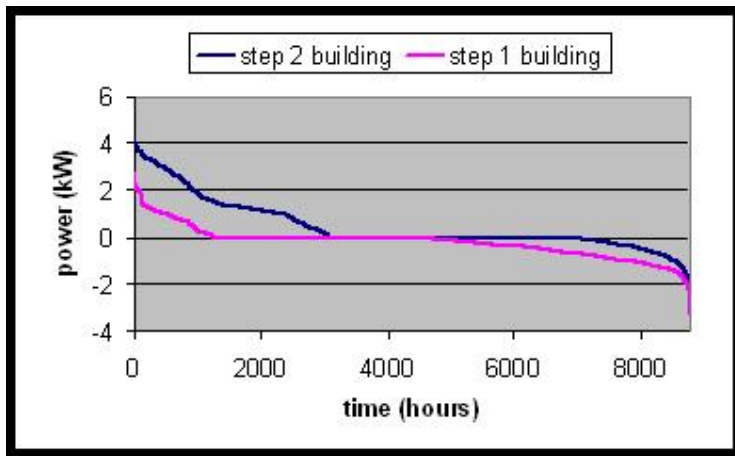

Load-duration curve for STEP 1 and STEP 2 design approach

The design of energy efficient buildings more and more needs a design approach in which design decisions logically and rationally can be made. The Trias energetica in combination with a load-duration calculations turns out to be very useful in practice. However, objective and transparent decision criteria between the different steps are not available and seems to be determined by daily practice. This leads at the moment to two different design approaches. The common approaches were a fairly good optimised dwelling combined with an optimal performing installation and an approach with an extreme insulated building in combination with a minimal installation.

References

Ad van der Aa, Ir. Nick van der Valk, Cauberg-Huygen Consulting Engineers, The Netherlands.

Energy Triangle

Description of method

The Energy Triangle is a method described by Haase and Amato (2005). The method involves a three steps approach is proposed that is related to the work of Lysen (1996). The energy triangle approach is based on the following considerations. First, it is necessary to analyse the energy that is consumed in order to be able to estimate the potential savings. Secondly, it is indispensable to reduce the energy consumption by using energy in the most efficient way. Third, the remaining energy need should be produced by means of renewable energy sources

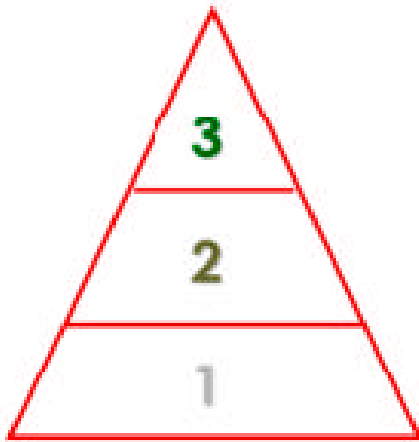

Building energy consumption

Energy triangle for low energy building design

1. Energy conservation: The building should be planned by making use of all energy conservation strategies
2. Increasing efficiency: all necessary energy consuming units in the building should be optimised by using the latest energy efficient devices and components
3. Utilization of renewable energy resources: for the remaining amount of necessary energy all renewable energy resources should be exploited and implemented.

Application of method

Haase and Amato (2005a, 2005b) has applied the method to the development of an innovative ventilation system that integrates climate responsive building elements with an innovative building envelope for an office building located in Hong Kong, which has a hot and humid climate.

First, the impact of building location and climate, size and orientation was analyzed with respect to thermal comfort and energy conservation. Then, six passive strategies for improving thermal comfort were investigated: 1) thermal mass effect, 2) exposed mass + night purge ventilation, 3) passive solar heating, 4) natural ventilation, 5) direct evaporative cooling, and 6) indirect evaporative cooling. The effect of the six strategies was illustrated using a psychometric chart. This resulted in the following conclusions:

- In subtropical climates with up to 7 months with HDD the maximum heating requirements in office buildings can be delivered by a passive solar heating strategy.
- Night purge ventilation needs a significant temperature difference during the night time.
- Natural ventilation has a high potential especially in April and October.
- Evaporative cooling strategies can only be applied to dry climates were it is possible to humidify the air.

Further analysis indicated that natural ventilation was the most promising strategy, however the problem of highly dynamic wind pressures had to be solved. A double-skin facade combined with a solar chimney was then suggested as a solution to this problem. For increasing the energy efficiency of the facade, optimum solar shading and ventilation strategies were suggested. For utilization of renewable energy, BIPV, solar assisted cooling and wind power were suggested in combination with the solar chimney.

Psychrometric Chart

Location: Hong Kong, China
 Data Points: 1st January to 31st December
 Weekday Times: 08:00-20:00 Hrs
 Weekend Times: 08:00-20:00 Hrs
 Barometric Pressure: 101.36 kPa
 ?A.J.Marsh '00

SELECTED DESIGN TECHNIQUES:

1. passive solar heating
2. thermal mass effects
3. exposed mass + night-purge ventilation
4. natural ventilation
5. direct evaporative cooling
6. indirect evaporative cooling

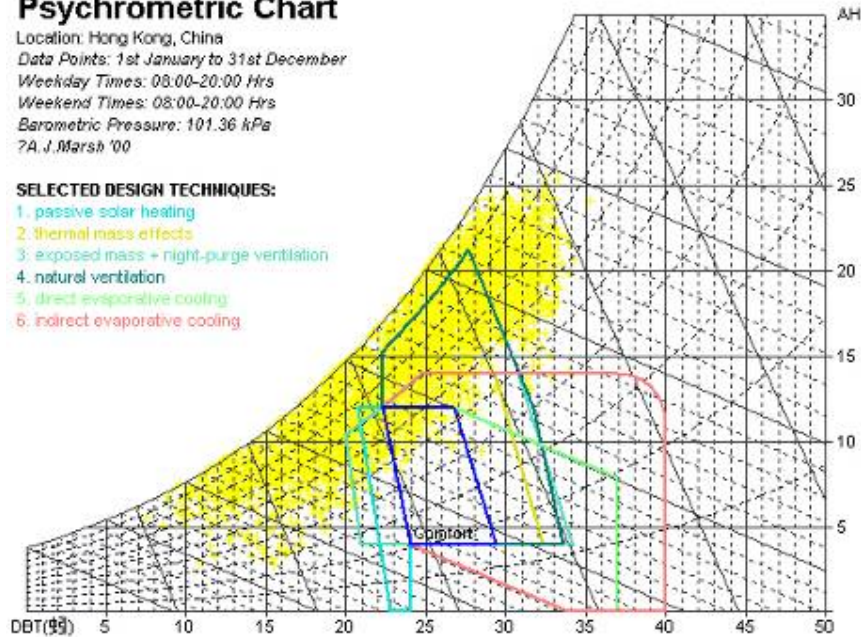

Potential of strategies for improve thermal comfort for Hong Kong.

Need for further research

Further investigation of the application of solar shading, ventilation strategies, BIPV, wind power and solar cooling to the concept.

References

- Haase, M. and A. Amato (2005a), "Development of a double skin facade system that combines airflow windows with solar chimneys", Paper at the World Sustainable Building Conference, September 27-29, Tokyo.
- Haase, M. and Amato, A. (2005b), "Fundamentals for climate responsive envelopes", Paper at Glass in Buildings 2CWCT, Bath, UK.
- Lysen, E. H. (1996), "The trias energica: Solar energy strategies for Developing Countries." *Eurosun Conference*, Freiburg, Germany.

The Kyoto Pyramid

Description of method

The Kyoto Pyramid is a strategy that has been developed for the design of low energy buildings in Norway. It is based on the Trias Energetica method described by Lysen (1996). The Kyoto Pyramid has been developed by SINTEF Byggforsk and the Norwegian State Housing Bank. The method consists of 5 steps, and there is one version for residential houses and one version for commercial buildings. For the design of low energy dwellings, the Kyoto Pyramid steps are:

1. *Reduce heat loss*
Super insulated and air tight envelope. Efficient heat recovery of ventilation air during heating season.
2. *Reduce electricity consumption*
Exploitation of daylight. Energy efficient electric lighting and equipment. Low pressure drops in ventilation air paths.
3. *Exploit solar energy*
Optimum window orientation. Atria/sunspaces. Proper use of thermal mass. Solar collectors. Solar cells.
4. *Control and display energy consumption*
Smart house technologies, i.e. demand control of heating, ventilation, lighting and equipment. User feedback on consumption.
5. *Select energy sources and carrier.*
E.g. heat pumps, biomass, district heating, electricity, natural gas.

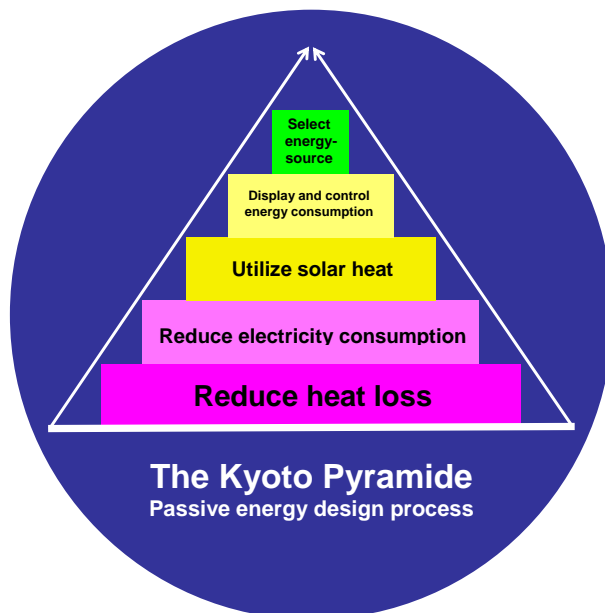

The Kyoto Pyramid for dwellings (A.Rødsjø, Husbanken).

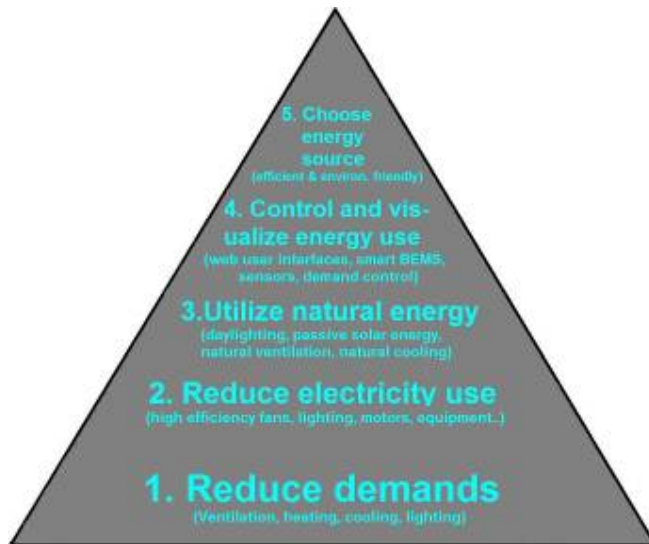

The Kyoto Pyramid for commercial buildings (T.H. Dokka, SINTEF).

Application of method

The method has been applied in the design stage of several low energy dwelling projects in Norway.

Benefits

The main benefit of the method is that it stresses the importance of reducing the energy load before adding systems for energy supply. This promotes robust solutions with the lowest possible environmental loadings.

Barriers

The cost-effectiveness of the energy supply systems may be reduced, due to the fact that the energy load is smaller. Thus the strategy may be opposed by equipment suppliers.

Need for further research

Implementation of the strategy into design tools and design processes.

References

Lysen, E. H. (1996), "The trias energetica: Solar energy strategies for Developing Countries" *Eurosun Conference*, Freiburg, Germany.

E-quartet

Description of tool

The "E-quartet" is an easy-to-use proposal tool that helps create an energy-saving building design and ensure an optimal equipment system from the points of view of economy, energy-saving and environmental problem. Highlights of the tool include:

- Input conditions of a building and equipment from dialogue boxes.
- Calculate initial costs, running costs, LCC, and LCCo2 at the same time.
- Examine various kinds of buildings with multi-purpose.
- Suitable for any place in Japan. Data of weather observation at 25 points and the charges for electricity and gas from every concerned company are embedded in the tool.
- Take energy-saving techniques of building design into consideration, such as changing the direction of a building, the position of a core, the position and size of a window or eaves, and the degree of heat insulation.
- Propose an optimal combination of energy-saving equipments such as cogeneration system, photovoltaics, wind power generator, natural ventilation, etc.

In this tool, investigation and comparison are conducted in the following items, and then a rational building design with an optimal equipment system can be proposed:

- Peak of heating and cooling load
- Annual HVAC load
- Initial and running cost
- The amount of primary energy consumption
- LCC and LCCo2

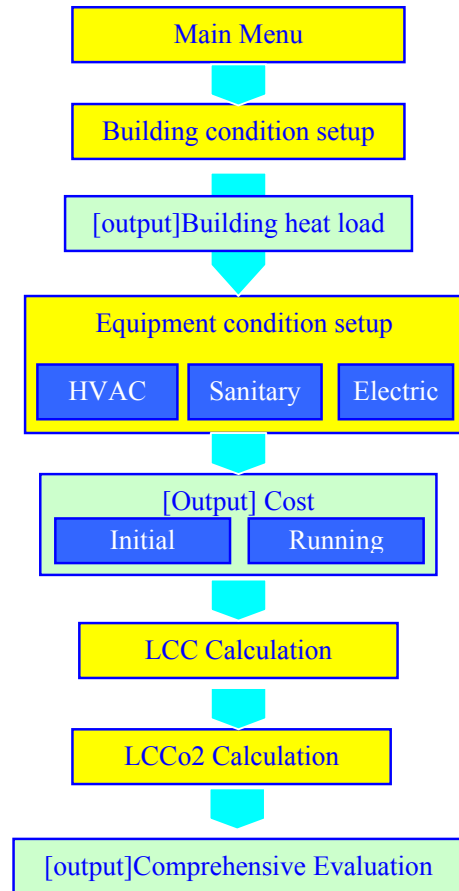

Outline flow of tool



Various kinds of buildings can be examined

Application of tool

The figure below shows the examination flow of this tool. First, we can input the general conditions of a building and its indoor thermal condition at a maximum pattern of 6. After calculation, we select one pattern by considering of air-conditioning peak load and annual load. Next, we input conditions of equipments such as air-conditioning system and sanitary fittings etc, and then calculate the initial cost and running cost of them. The combinations of the equipment are allowed to be 8 at maximum. Then we can select 4 types of combination at maximum from those results. At last, we also calculate the life cycle cost and life cycle CO₂ discharge of them. The figure below shows an example of output. An optimal design of the building can be decided by the peak load of HVAC. In addition, results of annual load of HVAC will be also considered (upper figures). Overall performance of 4 types selected is outputted, and these results will provide us with a decision of optimal building with comprehensive survey (lower figures).

References

SATAKE Akira, at MAEDA Corporation, Japan.

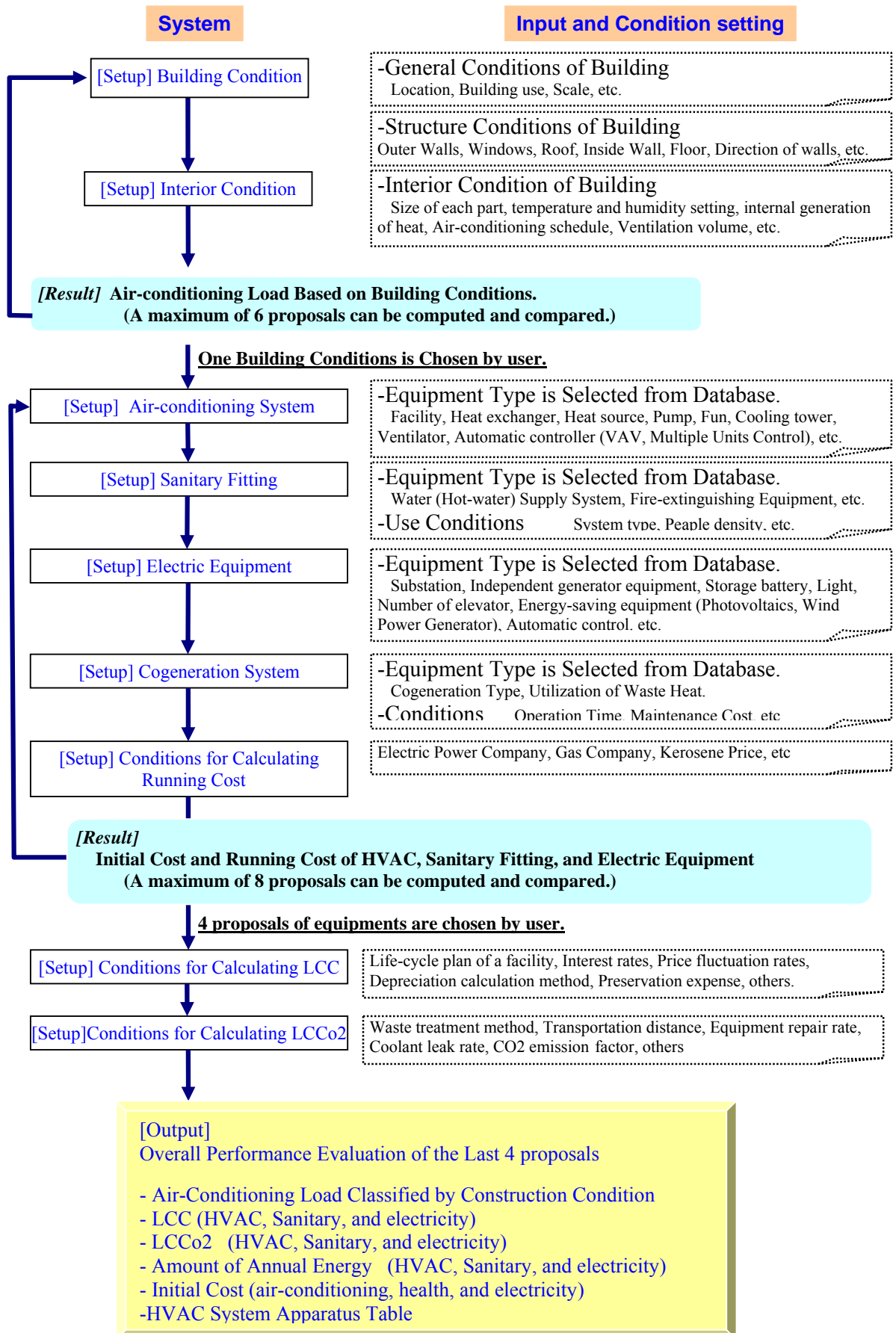



Example of output (examination)

Eco-Facade Tool

Description of tool

The Eco-Facade Tool is a concept design tool for evaluating environmental impacts of façade designs. The design of a building facade influences internal thermal and lighting conditions and energy use associated with the provision of these conditions. Key decisions about the building façade are usually taken during the concept design stage of a building while decisions about the method of providing the environmental conditions are often taken later in the design process. This dilemma is addressed by the concept design tool, which allows the design team to investigate the effect of façade design on the resulting internal environmental conditions, energy use and environmental impact. The concept design tool has been developed by performing detailed thermal, lighting and environmental modelling for a number of generic office building façade designs and a range of parameters which directly affect the environmental performance of an office building. The results are presented in a user-friendly interface requiring a minimum number of inputs. Key parameter outputs (such as temperature, lighting levels, heating/cooling energy demand, embodied energy and ecopoints) can then be viewed while a more detailed analysis can also be created for specified façade designs.

The tool was developed by using three simulation models:

- A dynamic thermal simulation model provided energy demand and internal thermal conditions data.
- A steady state lighting simulation model calculated the lighting environment based on the optical properties associated with the facade. The lighting model shared a common model format with the dynamic thermal modelling tool.
- A Life Cycle Analysis (LCA) accounting tool, calculated the impacts associated with the construction and use of the building based on information about the construction and energy use in the building over a fixed time.

Two levels of information are contained within the output parameters. Key performance criteria have been chosen for the first level (summary results) while more detailed information is provided at a second level. The first level of results is described in this section and an example of the detailed results is presented in the form of a case-study in the following section. The detailed results include thermal comfort indicators (average hourly comfort internal temperature and relative humidity), daylight distribution diagrams, heating and cooling energy demand (for each month of the year and by category such as heating, cooling, humidification and dehumidification) and environmental impact indicators (eco-points arranged by sub-system of Manufacture, In Use Phase and Disposal of the materials to landfill and by the sphere in which those impacts occur such as Human Health, Eco System Damage and Resource Depletion).



Initial screen of the Tool indicating the required input and presenting summary outputs.

The initial screen of the Tool is shown in the figure above. It shows that the following parameters can be assessed very quickly describing the performance of a specific façade type throughout a whole year:

- Heating Energy Demand. This is the annual energy (normalised per m² floor area) required to maintain the set internal minimum air temperature during operation hours throughout the year.
- Cooling Energy Demand. This is the annual energy (normalised per m² floor area) required to maintain the set internal maximum air temperature during operation hours throughout the year. It applies to Type 2 office only.
- Maximum comfort temperature. This comfort index (average of surface weighted radiant and room air temperature) has been selected instead of air temperature because radiant temperature could play an important role in some façade types. For example, curtain wall facades can create a large cold or hot area within the space, which will significantly affect internal comfort. Comfort temperature is equivalent to dry resultant temperature (3) for indoor air speeds below 0.1m/s.
- Numbers of hours that maximum temperature exceeds 25°C and 28°C. This index is particularly important for naturally ventilated buildings for which recent research (3, 4) indicates that internal temperatures could be allowed to increase to a certain level and for a certain percentage of the year without affecting internal thermal comfort.

- Minimum comfort temperature. For a similar reason as for maximum temperatures, the comfort temperature index is used to describe the provision of minimum comfort conditions.
- Daylight Levels. An average daylight factor is provided which is calculated using algorithms set out in (5).
- Embodied Energy (ee). The overall energy used in a facade is likely to dominate its efficiency, but this must be traded off against the energy embedded in the building. The ee of a facade is a function of the materials used in its construction, and it gives some indication of a building's impact on the environment but it does not take into account the lifetime effects of the choices used (6). This is considered in the calculation of Eco-points.
- Eco-points. These are derived from the Eco Indicator method (7) of environmental impact assessment, developed using an attitude questionnaire, which attempted to assess the public attitude to environmental harm. The advantages of this method are that it has been widely tested and it is respected internationally. The data collected has Europe wide applicability, i.e. the data are normalised according to the environmental harm caused by one European citizen.

Application of the tool

The case-study is described in this section to demonstrate the type of summary and detailed results that the tool can provide. The user is required to select initially two input parameters; building type and façade type. For this case-study a type 2 office is selected with a curtain wall façade highly glazed (0.85 glazing ratio) and an insulated spandrel panel. The high quality construction system (HQS), a 'best practice' energy operation and no shading are selected.

For the inputs specified above the summary output results are shown in Figure 1 for four orientations. Annual cooling energy load ranges from 25.2 kWh/m² (for north facing façade) to 35.1 kWh/m² (for south facing façade) while the annual heating load ranges from 25.7 kWh/m². (for east and south facing facades) to 34.6 kWh/m² (for north facing façade). These can be easily converted to energy consumption by making rule-of-thumb assumptions about the type of fuel and AC system used. For example if the heating system is assumed to have an efficiency of 75%, from delivered gas to supplied heat, then the annual energy consumption for heating would be 18.9 - 26.3 kWh/m² while for a cooling system with a coefficient of performance (COP) of 3, the annual energy consumption for cooling would be 8.5 - 11.5 kWh/m². It should be noted that these results would not include energy required for distribution of heating and cooling which can be a significant percentage and would depend on the distribution system used. The overall environmental impact of the selected façade system would be 1610 MJ/m² embodied energy and the eco-points would range from 130 (east facing façade) to 155 (west facing façade). These values can be compared to alternative façade systems from within the tool to reach a decision of the relative environmental impact of the façade system selected.

Data available in the detailed output can be interrogated by the user for specific information. Standard tabular and graphical data are available. An example of graphical output for the south facing facade is shown in the following figures.

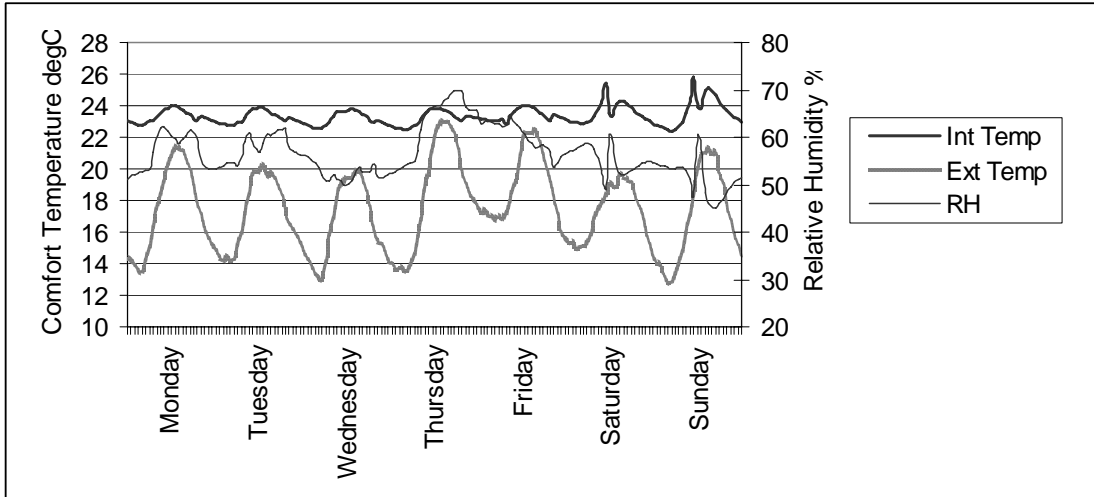

Case study profiles of internal comfort temperature and relative humidity and external air temperature for a week in summer with the highest weekly average external air temperature.

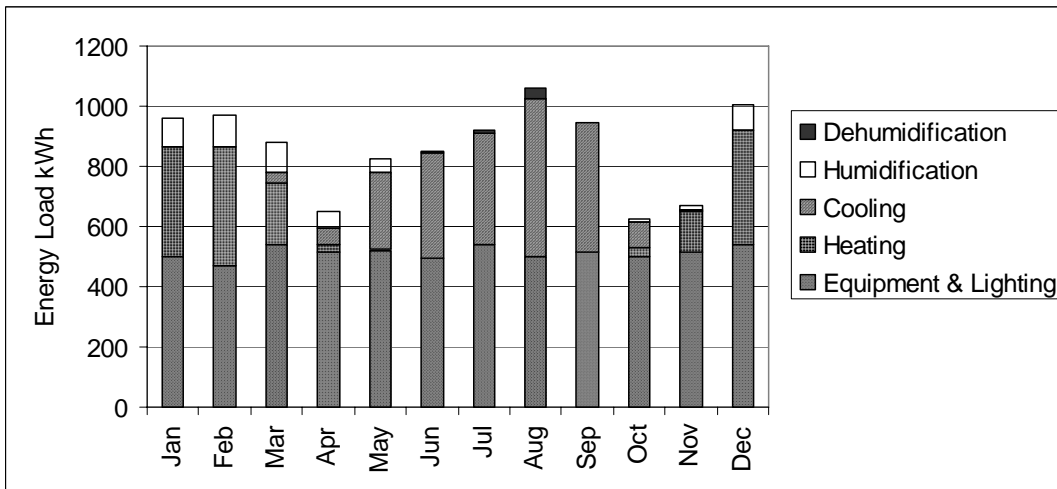

Case study profiles of energy loads for each month.

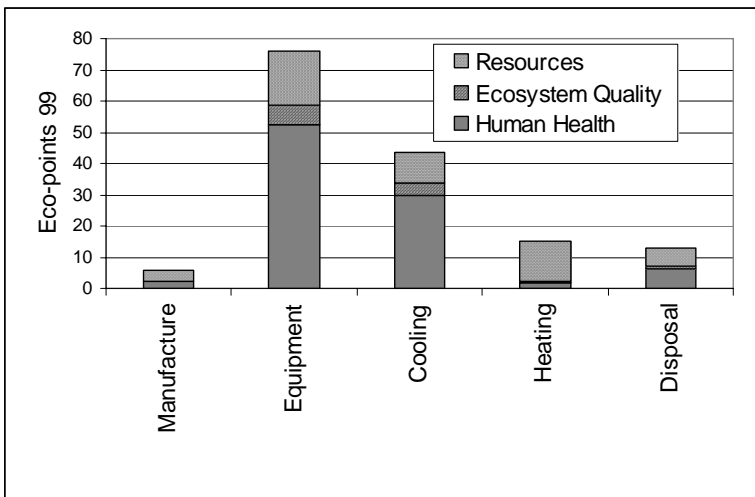

Case study environmental impact by sub-system and damage category.

Benefits

The tool has been discussed with designers within the authors' organisations who have commented positively on its educational value in promoting better understanding of the complex interaction between façade, building services and internal environment using a fast response interface.

Need for further research

Through discussions with designers the following topics were raised which merit further development:

- Financial implications of the façade options in particular the impact of the selection on the whole life cost in particular for the high quality facades which have a higher initial outlay but may result in lower whole life costs.
- Internal shading has not been considered in this study, as this requires user-behaviour scheduling of its use. However, such shading devices under user control would have a significant impact on energy consumption.
- Consideration of more complex variations of façade and building type; for example the retail sector.

References

Kolokotroni M, Robinson-Gayle S, Tanno S, and Cripps A, (2004). *Environmental impact analysis for typical office facades*, Building Research and Information, Vol 32, No 1, pp2-16.

Robinson-Gayle S (2003), Environmental impact and performance of transparent building envelope materials and systems, EngD thesis, Brunel University.

CIBSE Guide A, (1999). Environmental design, CIBSE.

Brager G S, de Dear E, (2000). A Standard for Natural Ventilation, ASHRAE Journal, pp21-28, ASHRAE.

CIBSE LG10 (1999). Daylighting and window design, Applications Manual, CIBSE.

Yates, A., Bartlett, P. and Baldwin, R. (1994). Assessing the Environmental Impact of Buildings in the UK. Paper presented at the conference of Buildings and Environment, BRE, Garston, England (BRE report EP223).

Goedkoop, M, Effting S. and Collignon M. (2000). Eco-indicator 99: A damage oriented method for life cycle impact assessment. PRé Consultants B.V., Amersfoort.

LEHVE Tool

Description of tool

The target of 2% decrease of CO₂ emission from household was set in broad outline of anti-global heating action (2000). It is necessary to establish a provision for controlling CO₂ emission from household which account for 15% of total emission in Japan and has been increasing constantly in recent year as soon as possible.

LEHVE was produced by "The R&D Project of Low Energy Housing with Validated Efficiency". This project is related the technology development project "Development of building and infrastructure technology for resource circulation society and safe environment" (NILIM) and is also working cooperation with "Development of circulation type dwelling working" (BRI). The objective of this project was to establish construction methods and design support systems which reduce the CO₂ emission from household by 50%. The following four tasks were performed by this project in order to accomplish this goal.

- A: Development of elementary technology for Energy Conservation
- B: Experimental Proof
- C: Development of design support system
- D: Spread promotion of Autonomous Housing

The Design Guideline of LEHVE is a design tool made through these four subjects, and architectural engineers are made a target. In this Design Guideline of LEHVE, The energy conservation technique to achieve the 50% reduction in energy consumption, the effect of energy conservation, running cost reductions, and a method for provisionally calculating the effect of CO₂ emission reduction, are introduced. The energy conservation technique are divided into 13 fields, and for each technique, the effect is concretely verified by experimental proof and simulations. A special feature of this guideline is the quantification of energy reduction for each of the 13 kinds of technologies. The target level of energy conservation is set to 13 kinds of elemental technologies techniques respectively, and the effects of each target level are quantified in each introduction techniques.

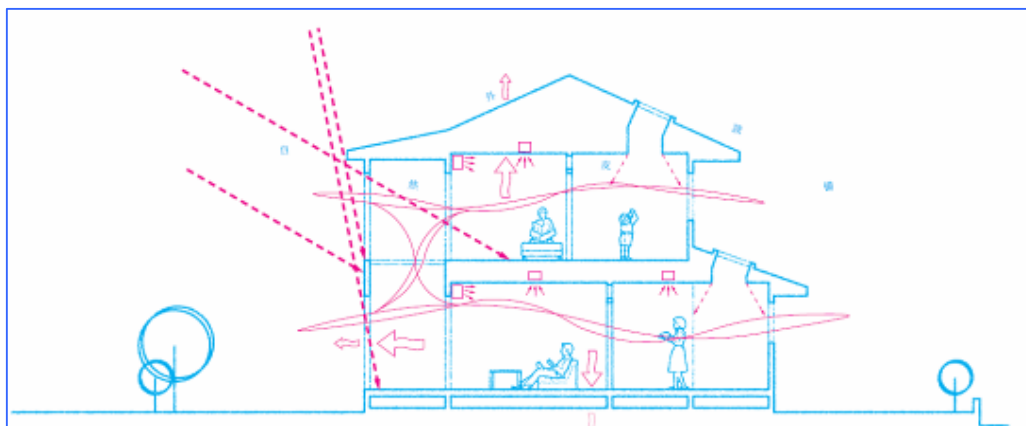

Book jacket of "Design Guideline of LEHVE"

For making the Design Guideline, the importance subject is a proof experiment. The objective of Experimental Proof is to assess the effectiveness of different kinds of energy conservation equipment and methods by mechanically reproducing the effects of occupant lifestyle

behaviors on model dwellings. For developing LEHVE, it is essential to evaluate the performance of energy consuming appliances and resource recycling systems in a status where they are actually operated in the house. By using two mock-up rooms of multiple-family residence, one with a conventional system and the other with a higher energy saving capability, the authors conducted comparative studies to verify the effectiveness of energy saving techniques and systems.



Test House of Experimental Proof

The characteristics of the experimental proof are as follows:

- Evaluation of energy consumption efficiency in accordance with the actual status of the application. (*Loads *Fluctuations *Operational Status *Mutual Effects)
- Evaluation of feasible/new technologies
- Paired evaluation of the amount of reduction in energy consumption (*Under the same climatic conditions *Using the same construction plans)
- Experimental proof facilities possessing high reproducibility

Results of the experimental proof, estimation of potential reductions in dwelling energy consumption, and compilation of information on viable energy conservation methods/technologies are offered to the Design Guideline of LEHVE.

There are 13 kinds of elemental technologies for LEHVE design included in the design book. These are five kinds of elemental technologies that correspond to “natural energy utilization techniques”, two kinds of elemental technologies that correspond to “thermal insulation techniques of building facades”, and six kinds of elemental technologies that correspond to “techniques of energy conservation equipment”. Design approaches whose effect on energy conservation were confirmed and recommended, was set to these technologies. Energy usage and those effects of energy conservation and level to be reduced by applying each element technology are arranged as shown in following Table. By using this base published in guideline book where more detailed energy conservation techniques and effects of reduction

are shown, the house designer can easily calculate the effect of the energy reduction and the effect of the reduction of carbon dioxide emissions.

Table: Effects level of energy conservation by applying each element technology

Elemental technology		Energy use of target for conservation	Effect and level of energy conservation
Utilization techniques of natural energy	Cross ventilation	cooling	-10 ~ -30% (Level ~3)
	Daylight	lighting	-2 ~ -10% (Level ~3)
	Photovoltaics	electricity	-29.3GJ ~ -39.1GJ (Level ~2)
	Solar radiation heat	heating	-5 ~ -40% (Level ~4)
	Solar water heater	hot-water supply	-10 ~ -30% or More (Level ~3)
Thermal insulation techniques of building facade	Housing insulation planning	heating	local intermittent heating -20 ~ -55% (Level ~4)
			whole house continuous heating -40 ~ -70% (Level ~4)
	Solar radiation shielding	cooling	-15 ~ -45% (Level ~3)
Techniques of energy conservation equipment	Air-conditioning equipment planning	heating cooling	air conditioner -20 ~ -40% (Level ~2)
			hot water floor heating + air conditioner -15 ~ -25% (Level ~3)
			central heating and cooling system -15 ~ -20% (Level ~2)
	Ventilation equipment planning	ventilation	-30 ~ -60% (Level ~3)
	Hot water apparatus	hot-water supply	-10 ~ -50% or More (Level ~4)
	Lighting equipment plan	lighting	-30 ~ -50% (Level ~3)
	Introduction of efficient appliances	appliance	-20 ~ -40% (Level ~3)
Processing and efficient use for water and raw garbage	water	water-saving equipment -10 ~ -40% (Level ~2)	

Application of tool

Since 2005, the workshop of LEHVE is held in places throughout the Japan, and the spread of LEHVE is advanced more since then.

References

Takao Sawachi, National Institute for Land and Infrastructure Management, Japan.

VentSim – Ventilation Network Analysis Tool

Description of tool

"VentSim" is a tool to calculate the airflow rate among multi zones based on the ventilation network analysis. The pre-processor "VentPre" is attached to "VentSim", and all data for "VentSim" is able to be input easily by using "VentPre". "VentSim" is used to the ventilation design by evaluating the ventilation performance (airflow rate, Supply Rate Fulfilment Index (SRF), contaminant concentration, and so on).

"VentPre" is pre-processor using Microsoft® Excel® worksheet with VBA.

- All data for "VentSim" is input easily by using "VentPre".
- Climate data for HASP (Heating, Air-conditioning, and Sanitary engineering Program) in 6 cities is available, and Expanded AMeDAS (Automated Meteorological Data Acquisition System) Weather Data at 842 points in Japan can be used.
- The properties of each room and airflow path are input on Excel® sheet easily. Simple opening, fan, infiltration and duct system can be set as airflow path.
- The parameters are input to calculate Supply Rate Fulfilment Index (SRF) and the contaminant concentration.

"VentSys" is the program to calculate the airflow rate among multi zones based on the ventilation network analysis. "VentSys" can calculate Supply Rate Fulfilment Index (SRF) and the contaminant concentration as well as the airflow rate. SRF is used to evaluate ventilation performance, and is based on the theory of conservation law of fresh air rate. The index is given by Eqn.1 and defined as the ratio of the effective supply rate S_i (Eqn.3) to the substantial required fresh air supply rate P_i' . The SRF value ranges from 0 to 1 and SRF=1 means the referenced room has sufficient effective fresh supply air rate compared to P_i' . S_i and P_i' are calculated by using α_i (surplus fresh air supply rate of the zone i , which is obtained by solving Eqn.2). α_i can be calculated when all airflow rates among zones in a building are known. The maximum value of α_i , 1.0 represents purely fresh air like outside air, and a negative value means there is no fresh air.

$$SRF_i = \frac{S_i}{P_i - \sum_{j=1}^n \min(0, \alpha_j Q_{ij})} = \frac{S_i}{P_i'} \quad (1)$$

$$\frac{d\alpha_i}{dt} V_i = A_i + \sum_{j=1}^n \alpha_j \cdot Q_{ij} \alpha_i \left(\sum_{j=1}^n Q_{ji} + B \right) - P_i \quad (2)$$

$$S_i = A_i + \sum_{j=1}^n \max(0, \alpha_j \cdot Q_{ij}) - \sum_{j=1}^n \max(0, \alpha_i \cdot Q_{ji}) - \max(0, \alpha_i \cdot B_i) \quad (3)$$

where

- A_i direct fresh air supply rate, the rate of air that is supplied directly from outside to room i [m^3/h]
- B_i rate of air exhausted directly to the outside from room i [m^3/h]
- M number of rooms for which the required fresh air supply rate is specified
- P_i required fresh air supply rate for room i [m^3/h]
- P_i' substantial required fresh air supply rate of room i [m^3/h]
- Q_{ij} transferred airflow rate, rate of air flowing from room j to room i [m^3/h]
- S_i effective fresh air supply rate of room i [m^3/h]
- V_i air volume of room i [m^3]
- n number of rooms
- α_i surplus fresh air supply rate contained in the air exhausted from room i

The figure below shows the configuration sheet of pre-processor "VentPre".

換気シミュレーション・計算設定データファイル		010209版
※ 欄のみデータを入力し、最後にCSV形式で保存して下さい。		
当ファイル名:	計算設定ファイル	(拡張子は不要です)
計算ケース数:	1	* Number of the calculation case
計算ケースNo	モデルデータファイル名 (拡張子は不要です)	計算結果ファイル名 (拡張子は不要です)
No1	Test4_2	Test4_2_out
No2		
No3		
No4		
No5		
気象データ種別:	0	気象データ使用せず
気象データ地域No:	0	
計算開始日:	1月1日	(月/日で入力してください)
計算終了日:	1月1日	(月/日で入力してください)
計算オプション		
SRF計算	0	計算しない
汚染物質濃度計算	0	計算しない
[濃度計算]時間分割数	60	
[濃度計算]出力ステップ数	30	
[濃度計算]最大出力時間	240	[時間]
[濃度計算]助走期間	1	[日]
[濃度計算]助走期間中のデータの保存	0	(0=保存しない、1=保存する)

* Select climate data
 HASP data in Japanese 6 city can be selected. And Expanded AMeDAS Weather Data can be used (842 points in Japan)

* [SRF] option and [contaminant concentration calculation] option are set.

* Unit, the convergent calculation configuration, file setting is also input.

Calculation configuration sheet of pre-processor "VentPre"

The figure below shows the model data sheet. The model data sheet is made in each calculation case.

ファン開口の数		ファン開口の属性									
ファン開口No	ファンNo	室番号が小さい方の室番号	室番号が大きい方の室番号	小さい室番号側の床からの高さ	大きい室番号側の床からの高さ	風圧係数コード番号	α A	ファンの番号	ファンの加圧方向	ファンの種類	
1				(m)	(m)		(cm ²)	小→大:1 大→小:n-1	0(=blank) or 1		
2											
3											
4											

* Simple opening, fan (left figure), infiltration (bottom figure) and duct can be set in VentPre.

建具の数		建具の属性													
建具No	室番号が小さい方の室番号	室番号が大きい方の室番号	小さい室番号側の床からの高さ	大きい室番号側の床からの高さ	風圧係数コード番号	開口巾	開口高	縫隙幅数	縫方向分割数	隙間特性 A-1	隙間特性 A-2	隙間特性 A-3	隙間特性 H-1	隙間特性 H-2	隙間特性 H-3
1			(m)	(m)		(m)	(m)								
2															
3															
4															

風圧係数コード一覧表			
係数コード番号	南	南西	南東
1	0.60		
2	0.50		
3	-0.20		
4	-0.90		
5	-0.40		
6			
7			
8			
9			

* Wind pressure code and wind pressure coefficient is set in each wind direction.

ファンの特性						
ファン種類	FLOW RATE WIDTH	1ST FLOW RATE	PRES S F1	PRES S F2	PRES S F3	PRES S F4
ファンNo	(m ² /h)	(m ³ /h)	(mm Aq)	(mm Aq)	(mm Aq)	(mm Aq)
1	10	40	-500	0	50	500
2						
3						
4						
5						
6						
7						
8						
9						
10						

* Fan list is set. Relation between pressure and flow is input.

Model data sheet of pre-processor "VentPre"

CSV file for "VentSim" is output after inputting all data on "VentPre" sheet, and the result of airflow rate is obtained from "VentSim". The figure below shows part of the result CSV file.

空間No	名称	室温(℃)	ER(m³/h)/PRESS (Pa)
1	居間兼事務室	26	-2.97E-04
2	台所	26	2.52E-03
3	練間	26	-5.97E-04
4	和室	26	1.08E-03
5	1階廊下	26	2.62E-04
6	玄関ホール	26	9.59E-04
7	洗面所	26	2.48E-04
8	1階トイレ	26	1.55E-03
9	浴室	26	5.16E-05
10	1階階段	26	-9.21E-04
11	2階階段	27.5	4.45E-03
12	2階ホール	27.5	-1.92E-04
13	書斎	27.5	-1.87E-03
14	納戸	27.5	9.51E-03
15	2階トイレ	27.5	3.25E-03
16	2階洗面所	27.5	-4.95E-03
17	個室1	27.5	7.77E-03
18	個室2	27.5	7.89E-03
19	個室3	27.5	6.62E-03

開口No	FLOW RATE(m³/h)
単統-1	975.8603
単統-2	1129.158
単統-3	-26.7841
単統-4	-26.6809
単統-5	-26.6809
単統-6	-25.4519
単統-7	-1008.5
単統-8	-10679
単統-9	-80153
単統-10	-600153
単統-11	-508.014
単統-12	-585.182
単統-13	-85.7665
単統-14	-23.4579
単統-15	-59.8745
単統-16	-27.7594
建物全体	4111.029

Part of result from "VentSim"

Application of tool

The figure below shows an example of examination of the effect of "Ranma" for cross ventilation at nighttime. "Ranma" is a Japanese traditional opening to take airflow between rooms, and is re-evaluated as another opening that is set on upper side of door. Left figure is the case that "Ranma" on partition wall are opened, and right figure is the closed case. The airflow rate in the private rooms in the left case is 2~6 times larger than in the right case, and the airflow rate is enough for the left case.

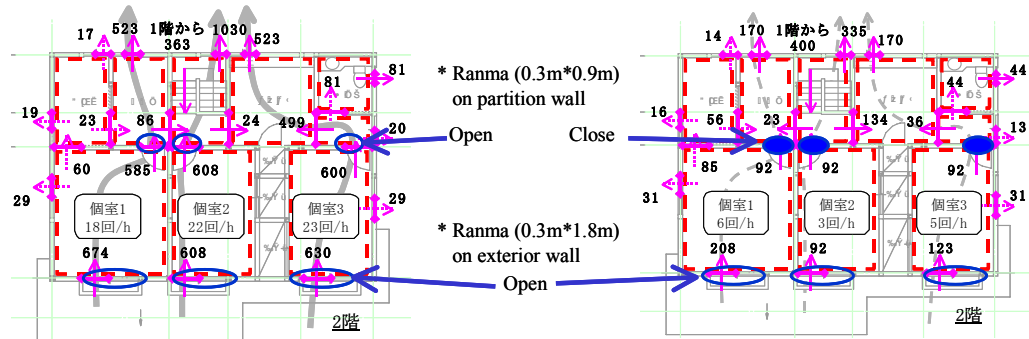

One result of airflow rate under cross ventilation

The figure below shows example of airflow rate in the flat. The mechanical ventilation system is examined by airflow rate and SRF.

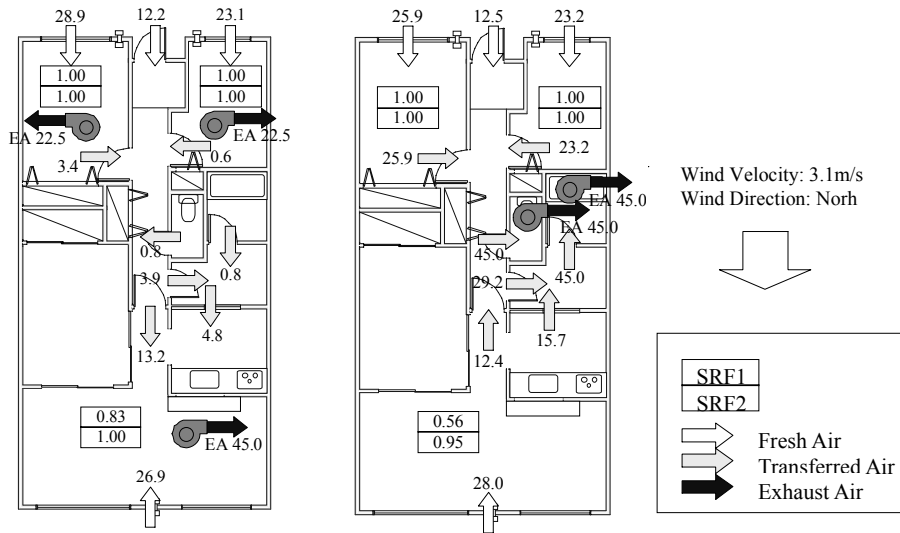

Airflow rate and performance of mechanical ventilation in flat

References

NISHIZAWA Shigeki, at Building Research Institute, Japan.

Computer Simulation Tools

A comprehensive overview of building energy performance simulation programs may be found at www.energytoolsdirectory.gov. At this web-page, one may also find a report by Crawley et al (2005) contrasting the capabilities of 20 building energy performance simulation programs: BLAST, BSim, DeST, DOE-2.1E, ECOTECH, Ener-Win, Energy Express, Energy-10, energyPlus, eQUEST, ESP-r, IDA ICE, IES <VE>, HAP, HEED, PowerDomus, SUNREL, Tas, TRACE and TRNSYS. The comparison includes the following categories:

- Zone loads
- Building envelope
- Daylighting and solar
- Infiltration
- Ventilation and multizone airflow
- Renewable energy systems
- Electrical systems and equipment
- HVAC systems
- HVAC equipment
- Environmental emissions
- Economic evaluation
- Climate data availability
- Results reporting
- Validation
- User interface
- Links to other programs
- Availability

Another useful overview of building energy performance simulation tools has been presented by Wachenfeldt (2003), see the table next page.

References

Crawley et al (2005), “Contrasting the Capabilities of Building Energy Performance Simulation Programs”, United States Department of Energy, University of Strathclyde, University of Wisconsin.

Wachenfeldt, B. J. (2003), “Trial lecture for PhD defense at the Norwegian University of Science and Technology, Trondheim, Norway.

Overview of simulation tools by Wachenfeldt (2003).

TOOLS:	ESP-r	TRNSYS	EnergyPlus	APACHE	Energy-10	IBLAST	DOE-2	BSIM 2002	SCIAC Pro	IDA	Microflo	Fluent Airpac	CFX	FLOVENT	COMIS	COMTAM	Radiance	ADELIN	Window 5	
Air flow and IAQ-related:																				
Airflow network with ext. pressure	Y3	YL	Y3																	
General contaminant/CO ₂ transport	N	YL		YL	N	N	N	N	N	N	YL	Y3	Y3	Y3	Y3					
Moisture transport	Y	N		N	N	N	N	N	N	N	N	N	N	N	N					
Contaminant source/sink effects	N	N	N	YL	N	N	N	N	N	N	N	N	N	N	N					
Air cleaning	N	N	N	YL	N	N	N	N	N	N	N	N	N	N	N					
Contaminant gradients	Y3	N	N	N	N	N	N	N	N	N	Y3	Y3	Y3	Y3						
Computational fluid dynamics	Y3	N	N	YL	N	N	N	N	N	N	Y3	Y3	Y3	Y3						
Energy flow and HVAC:																				
Heat Balance	Y	Y	Y	Y	Y	Y	N	Y	Y	Y	Y	Y3	Y3	Y3						
Advanced interior surface convection	Y3	Y1	Y2	N	N	N	Y2	Y1	N	N	N	Y3	Y3	Y3						
Electric power flow	Y3	Y3	Y3	N	N	N	N	N	N	N	N	N	N	N						
Renewable energy conversion Syst.	Y3	Y3	Y3	N	N	N	N	N	N	N	N	N	N	N						
Fluid loops	Y	Y	Y	Y	N	N	N	N	N	N	N	N	N	N						
Air loops	Y	Y	Y	Y	N	N	N	N	N	N	N	N	N	N						
User configurable HVAC systems	Y1	Y3	Y2	Y	N	N	N	N	N	N	N	N	N	N						
High temp. radiant heat trans.	Y2	Y3	Y3	Y	N	N	N	N	N	N	N	N	N	N						
Low temp. radiant heat trans.	Y2	Y2	Y3	Y	N	N	N	N	N	N	N	N	N	N						
Solar and lighting:																				
Anisotropic sky model for diff. rad.	Y	Y	Y	Y	Y	N	Y	Y	N	Y	N	N	N	N				Y3	Y	N
Daylight control/shading	Y2	N	Y3	Y	Y3	N	Y	Y	Y1	Y3	N	N	N	N				Y3	Y	N
Advanced daylight illumination	Y1	N	Y2	Y	Y1	N	Y	Y1/YL	N	Y3	N	N	N	N				Y3	Y	N
Advanced fenestration calculations	Y2	N	Y3	Y	Y	N	Y	Y2	Y2	Y2	N	N	N	N				Y3	Y	N
Advanced window calculations	Y2	Y2	Y3	N	N	N	Y	N	Y1	Y1	N	N	N	N				N	N	Y3
Various other capabilities:																				
Integrated simultaneous solution	Y3	Y3	Y3	Y	Y1	Y	N	Y	Y2	Y3	YL	Y	Y	Y	N	N		YL	N	N
Multiple timestep	Y3	Y3	Y3	Y	N	N	N	N	Y2	Y3	Y	Y	Y	Y	N	N		YL	N	N
Advanced control algorithms	Y3	Y3	Y3	Y	N	N	N	N	Y1	Y3	YL	Y	Y	Y	N	N		YL	N	N
Multiple zone capabilities	Y3	Y3	Y3	Y	Y1	Y	Y	Y3	Y2	Y3	YL	N	N	N				YL	N	N
Input functions	N	Y3	Y	N	N	N	N	N	Y	Y3	Y	Y	Y	Y	YL	Y3		YL	Y	N
Graphical user interface/CAD facility	Y2	YL	N	Y	Y3	Y	Y	Y3	Y2	Y3	Y	Y3	Y3	Y3	YL	Y3		YL	Y3	N
Graphical user report mechanism	Y2	YL	N	Y	Y3	Y	Y	Y3	Y2	Y3	Y	Y3	Y3	Y3	YL	Y3		YL	Y3	N
Particular building design facilities	Y3	YL	Y	Y	Y3	Y	Y	Y3	N	Y3	Y	Y3	Y3	Y3	N	N		N	Y	N
Thermal comfort	Y	Y	Y	Y	Y	Y	Y	Y	Y	Y	N	Y3	N	Y3	N	N		N	N	N
Atmospheric pollution	N	N	N	Y1	N	Y	Y	N	Y1	N	N	N	N	N	N	N		N	N	N
Life cycle assessment	Y2	N	N	N	N	N	N	N	N	Y1	N	N	N	N	N	N		N	N	N
Acoustics	Y	N	N	N	N	N	N	N	N	N	N	N	N	N	N	N		N	N	N
Import from CAD-tools	Y2	YL	Y	Y	N	N	N	N	Y3	Y1	Y3	Y	Y	Y	N	N		N	Y1	N
Link to TRNSYS	N	N	N	N	N	N	N	N	N	N	N	N	N	N	Y	N		N	Y1	N
Link to Radiance	Y3	N	Y	N	N	N	N	Y1	N	N	N	N	N	N	N	N		N	N	N
Link to ESP-r	N	N	N	N	N	N	N	N	N	N	N	N	N	N	N	N		Y3	N	N
Link to APACHE	N	N	N	N	N	N	N	N	N	N	Y3	N	N	N	N	N		N	N	N
Link to Microflo	N	N	N	Y3	N	N	N	N	N	N	N	N	N	N	N	N		N	N	N
General public licence	Y	N	N	N	N	N	N	N	N	N	N	N	N	N	N	N		N	N	N
FREE version exists	Y	N	Y	N	N	N	N	N	N	N	N	N	N	N	Y1	Y2		N	N	N
Runs under windows	Y1	Y	Y3	Y	Y	Y	Y3	Y	Y	Y	Y	Y	Y	Y	Y	Y		N	N	N
Runs under Linux/Unix	Y3	N	Y	N	N	N	N	N	N	N	N	N	N	N	Y1	N		N	N	N
Programming language	F77/C	F77	F90	YB,C++	F77	Visual C++	F77	Visual C++	Visual C++			C++	F90		F77	C		F77	F77, C	Div

Signification:
 Y = a general Yes.
 Y1 = Yes, but only with limited features, models and/or capabilities.
 Y2 = Yes, with "standard" features, models and/or capabilities.
 Y3 = Yes, with "state of the art" features, models and/or capabilities.
 YL = Yes, but only through integrated coupling with another tool.
 N = No.

Definitions:

Air flow and IAQ-related:	
Airflow network with ext. pressure nodes	Network with air nodes, connecting ambient nodes, zones, fans, coils, mixing boxes etc. The pressure at the ambient nodes serves as boundary conditions, taking wind and thermal buoyancy into account when solving the network.
General contaminant/CO ₂ transport	Allowing for the transport of general contaminants such as CO ₂ with the inter-zone airflow.
Moisture transport	Moisture transport as well as transport within the building fabric; for detection of condensation.
Contaminant source/sink effects	Models for pollutant source and sink effects.
Air cleaning	Models for air cleaners as filters and dispersion.
Contaminant gradients	Models for contaminant-gradients within zones (i.e. not the full-mixing assumption).
Computational fluid dynamics	Solving the mass, energy and momentum equations through computational fluid dynamics (CFD), including turbulence models, models for thermal buoyancy etc.
Energy flow and HVAC	
Heat Balance	Simultaneous calculation of radiation and convection processes each time step.
Advanced interior surface convection	Dependent on temperature and air flow and thermal mass.
Electric power flow	Solving a nodal voltage network for modeling of e.g. PV-panels.
Renewable energy conversion Syst.	Model capabilities for renewable energy conversion systems as ducted wind turbines, phase change materials, PV-panels etc.
Fluid loops	Solving a liquid plant network.
Air loops	Solving a network of air nodes for the plant.
User configurable HVAC systems	Containing a variety of pre-defined plant components with adjustable parameters.
High temp. radiant heat trans.	Models for gas/electric heaters and wall panels.
Low temp. radiant heat trans.	Models for heated floors/ceiling and cooled ceilings.
Solar and lighting	
Anisotropic sky model for diff. rad.	Models for the effect of solar position on the diffuse radiation.
Daylight control/shading	Models for shading blocks, blinds, curtains etc. and related control algorithms.
Advanced daylight illumination	Models for prediction of lux-levels and daylight factors within the building.
Advanced fenestration calculations	Models for electromagnetic glazings, double facades, particular coatings, solar incident angle-dependent properties etc.
Advanced window calculations	Models for layer-by-layer input for custom glazing, including low e-coatings etc.
Various other capabilities:	
Integrated simultaneous solution	Solving the whole system simultaneously, requiring iterations within each time step.
Multiple timestep	Possibilities for variable timesteps, and different timestep for the solution of e.g. the thermal model and the HVAC system.
Advanced control algorithms	Advanced control-options for airflow openings, plant, electrical system etc. (e.g. PID-controllers and fuzzy-logic controllers)
Multiple zone capabilities	Solving complex buildings with many zones.
Input functions	Possibilities and flexibility with respect to input-functions to solve particular problems without having to recompile source-code.
Graphical user interface/CAD facility	Ease of use, capabilities, integrated cad tool.
Graphical user report mechanism	Fast and easy presentation of multiple results.
Particular building design facilities	Particular features adapted for the design process, e.g. integrated performance view, algorithms for parametric studies etc.
Thermal comfort	Models for thermal comfort prediction, e.g. the predicted percentage of dissatisfied (PPD) and predicted mean vote (PMV).
Atmospheric pollution	Models for prediction of emissions to the environment.
Life cycle assessment	Methods for life cycle assessment of costs/energy/environmental impact.
Acoustics	Models for prediction of acoustical performance.
Import from CAD-tools	Ability to import various CAD-formats.
Link to TRNSYS	Coupling with TRNSYS, allowing for integrated evaluation of several parameters.
Link to Radiance	Coupling with Radiance, allowing for integrated prediction of solar radiation-effects within the building.
Link to ESP-r	Coupling with ESP-r, allowing for integrated evaluation of several parameters.
Link to APACHE	Coupling with APACHE, allowing for integrated evaluation of several parameters.
Link to Microflo	Coupling with Microflo, allowing for integrated evaluation of airflow.
General public licence	Source code available under General Public License (GPL).
FREE version exists	Free version exists.
Programming language	Programming language of "simulation-engine" and eventually also the interface.

Uncertainty in Building Performance Assessment

Introduction

In the design of integrated building concepts it is crucial to be able to predict the building performance with a satisfactory accuracy, especially, when selection between alternative design solutions is needed or if the aim is to perform an optimization of the building performance. When expressed in suitable indicators as primary energy use, environmental load and/or the indoor environmental quality, the building performance simulation provide the decision maker with a quantitative measure of the extent to which the design solution satisfies the design requirements and objectives.

It is essential that the simulation result reflects the characteristics of the building and its technical systems and is able to simulate the building performance with a satisfactory accuracy - that the results are reliable and comparable. Traditionally, building performance simulation is based on a deterministic approach, which implies that the spread of input parameters is zero. However, to be able to compare different design alternatives against each other it is necessary also to estimate how reliable a design is, i.e. to quantify the uncertainty that is affiliated to the simulated result of each design alternative. This can contribute to more rational design decisions. At the same time it may lead to a more robust design due to the fact that the influence of variation in important design parameters has been considered.

The different sources for uncertainties can be divided into four different categories:

- Uncertainties in the physical model of the building and its technical systems.
 - Algorithms used in the software are simplifications/models of the physical system
 - Models for different parts of the system have typically not the same level of detail
- Uncertainties in the software and the numerical solution of equations.
 - Programming errors will always exist in detailed software tools.
 - Numerical solution of the governing equations is an approximation of the real solution.
- Uncertainties introduced by the operator of the software
 - The real system is very complex, which requires that approximations and simplifications are made. Different operators make different decisions on this
 - Operators make mistakes when running the software
- Uncertainties in selection of scenarios and parameter estimation
 - Different scenarios can be selected for simulation, as it is very difficult to predict future use of a building
 - Modeling requires a huge number of different input parameters which are not well defined
 - Lack of information may lead to the use of “educated guesses”.
 - Imprecision in the construction process and natural variability in properties of building components and materials will also occur.

The first two categories of uncertainties are dealt with and minimized in the development and validation of the simulation models and software tools, while the two last are dominating in the application phase. The following focuses on the application phase and especially on the

uncertainties introduced in the selection of modeling scenarios and estimation of input parameters.

Description of method

An *Uncertainty Analysis* determines the total uncertainty in model predictions due to imprecisely known input variables, while a *Sensitivity Analysis* determines the contribution of the individual input variable to the total uncertainty in model predictions. The sequence of the two analysis methods is quite arbitrary as it is an iterative process, especially for large models, as it is the case for simulation of the performance of integrated building concepts.

First of all it must be decided if the uncertainty in model predictions is considerable. This is most often based on subjective judgment in the first case. Next step is a screening analysis (based on a simplified sensitivity analysis) that limits the number of investigated parameters to a manageable amount and, finally, an uncertainty analysis determines if the uncertainty is considerable. If so, a sensitivity analysis is performed to identify the most important parameters. Then these are defined more precisely and an uncertainty analysis evaluate, if the uncertainty has decreased to an acceptable level. If not, the iterative process is repeated until an acceptable level is found and/or the actual level of uncertainty is known. Usually, after the initial screening analysis it is only necessary to run the process one or two times to reach acceptable results.

Probability density functions

Variable and/or uncertain input parameters are described by a probability density function, which are used in the investigation and quantification of their importance for model outputs – simulation results.

If appropriate data are available, it may be possible to estimate distributions and distribution parameters for the input data with formal statistical procedures. Unfortunately most parameters are not amenable to statistical analysis. In most cases it is only possible to estimate the limits for the variation of the parameters, estimate the most probable value of the parameter within the limits and choose the most appropriate probability density function. Sensitivity analysis results generally depend more on the selected ranges than on the assigned distributions. However, distributional assumptions can have an impact on the estimated distributions for output variables.

Typically three different functions are used (see figure):

- Normal distribution
- Log-normal distribution
- Uniform distribution

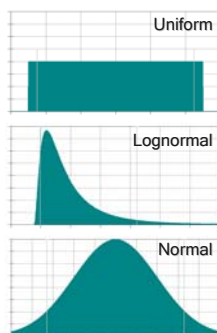

Probability density distributions usually applied in sensitivity and uncertainty analysis.

A parameter is considered to be *sensitive*, if its value can vary considerably. These parameters are the ones selected for sensitivity analysis. If variation of the parameter results in considerable variation in model output – simulation results, the parameter is considered to be *important*. The result of the sensitivity analysis is a list of important parameters, which are the ones selected for the uncertainty analysis.

Uncertainty analysis (UA) and sensitivity analysis (SA)

Sensitivity analysis can be grouped into three classes:

- Screening methods. Are used for complex models which are computational expensive to evaluate and have a large number of input parameters. An economical method that can identify and rank qualitatively the parameters that control most of the output variability. Are often so-called OAT-methods (One-parameter-At-a-Time) in which the impact of changing the values of each parameter is evaluated in turn (partial analysis). A calculation using “standard values” is used as control. For each parameter, usually two extreme values are selected on both sides of the standard value. The differences between the result obtained by using the standard value and using the extreme values are compared to evaluate, which parameters the model is significantly sensitive to.
- Local sensitivity methods. Is an OAT approach, where evaluation of output variability is based on the variation of one parameter, while all other parameters are held constant. Useful for comparison of the relative uncertainty of various parameters. The input-output relationship is assumed to be linear and correlation between parameters is not taken into account.
- Global sensitivity methods. Is an approach, where output variability due to one parameter is evaluated by varying all other parameters as well, and where the effect of range and shape of their probability density function is incorporated.

The basic steps in a sensitivity analysis, see figure below, include:

1. Identification of questions to be answered by the analysis, define output variable(s)
2. Determine input parameters to be included by an initial screening analysis
3. Assign probability density functions to each parameter
4. Generate an input vector/matrix (maybe considering correlation)
5. Create an output distribution and evaluate the model uncertainty
6. Assess the influence of each input parameter on the output variable(s)

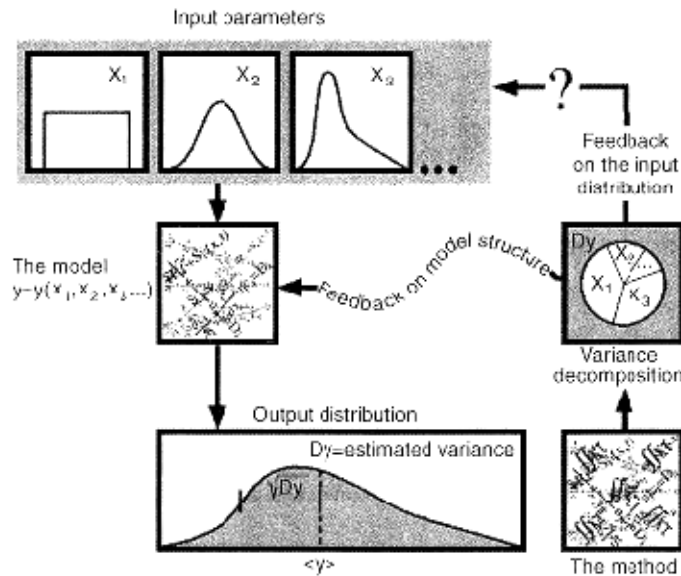

Basic steps in sensitivity analyses. From Saltelli et al., 2000, p. 7.

A number of different mathematical methods for sensitivity analysis can be found in the literature (Saltelli et al. 2000a,b; Hamby, 1994; Lam and Hui, 1996; Lomas and Eppel, 1992; Morris, 1991).

Based on the available information the Morris method (Morris, 1991) is evaluated as the most interesting for screening analysis as:

- The method is able to handle a large number of parameters
- It is economical – the number of simulation is few compared to the number of parameters
- It is not dependent on assumptions regarding linearity and/or correlations between parameter and model output
- Parameters are varied globally within the limits
- Results are easily interpreted and visualised graphically.
- Indicates if parameter variation is non-linear or mutually correlated.

To estimate simulation uncertainty Monte Carlo analysis are often used. By generating a series of random combinations of input parameters the simulation results can be used to determine both uncertainty in model predictions and apportioning to the input parameters their contribution of this uncertainty.

A Monte Carlo analysis involves a number of steps. The first step is based on the probability density functions of each parameter to generate random samples of input parameters. Various sampling procedures exist among which are: random sampling, Latin hypercube sampling and quasi-random sampling. Control of correlation between variables within a sample is extremely important and difficult, because the imposed correlations have to consistent with the proposed variable distribution. A method is proposed by Iman and Conover (1982). The second step is the evaluation of the model for each sample of input parameters. The third step

is the uncertainty analysis, where the expected value and the variance for the output parameter(s) are estimated. The final step is the sensitivity analysis to apportion the variation in the output to the different sources of variation in the system. A number of different techniques can be used, like rank transformation, regression analysis and scatter plots, yielding different measures of sensitivity, Saltelli et al. (2000a).

Uncertainty and sensitivity analyses can in principle be used for all kinds of projects, however, the more spread found in the various input parameters and the higher the sensitivity to those parameters, the more benefit will be gained from the analyses. For instance, it will obviously be more beneficial to perform an uncertainty analysis for a naturally ventilated light building than for a traditional fully air-conditioned heavy type of building.

The UA/SA analyses will typically be performed by consulting engineers preferably at a reasonably early stage of the building process where it is still possible to influence the important parameters. It may be very useful to apply the analysis at two stages; for the initial design where the overall important parameters are determined and later on when the detailed design is worked out and, for instance, the building services are considered.

The analyses will usually focus on the building energy consumption (e.g. kWh/(m² year)) and the indoor environmental quality (e.g. average/cumulated PPD, number of hours exceeding a certain predefined temperature etc.). The building costs may be linked to the UA/SA analyses and form an integrated part of the entire decision process.

Application of method

In order to illustrate the use of the model an example of evaluation of the thermal comfort conditions in a naturally ventilated atrium in an office building in Denmark is described in this section. The figure below shows the atrium and the office building. The building and the atrium is in two stories. The atrium is naturally ventilated with openable windows in the façade and in the roof.

The thermal comfort conditions in the atrium is determined by a number of parameters as i.e. solar radiation, solar shading, internal heat load, thermal mass, opening area, outdoor temperature, wind speed, wind direction, etc. 17 potentially important parameters were identified for the atrium and a sensitivity analysis was performed using the Morris method and an uncertainty analysis using the Monte Carlo method.





Ny Allerødgård naturally ventilated office building and atrium, HQ for Sjælsø Gruppen (major Danish developer company).

From the sensitivity analysis it was possible to identify the most important parameters. The figure below shows the evaluation of the thermal comfort conditions in the atrium for the four most important parameters expressed by the distribution of PPD (Predicted Percentage of Dissatisfied). The average PPD value of the reference case is 29.8%. The similar value, if all 17 parameters are included in the uncertainty analysis, is an average PPD value of 23.2% and a standard deviation of 3.7%, see table below. The most important parameters were the temperature set point for venting, the opening area, background ventilation level and the level of infiltration.

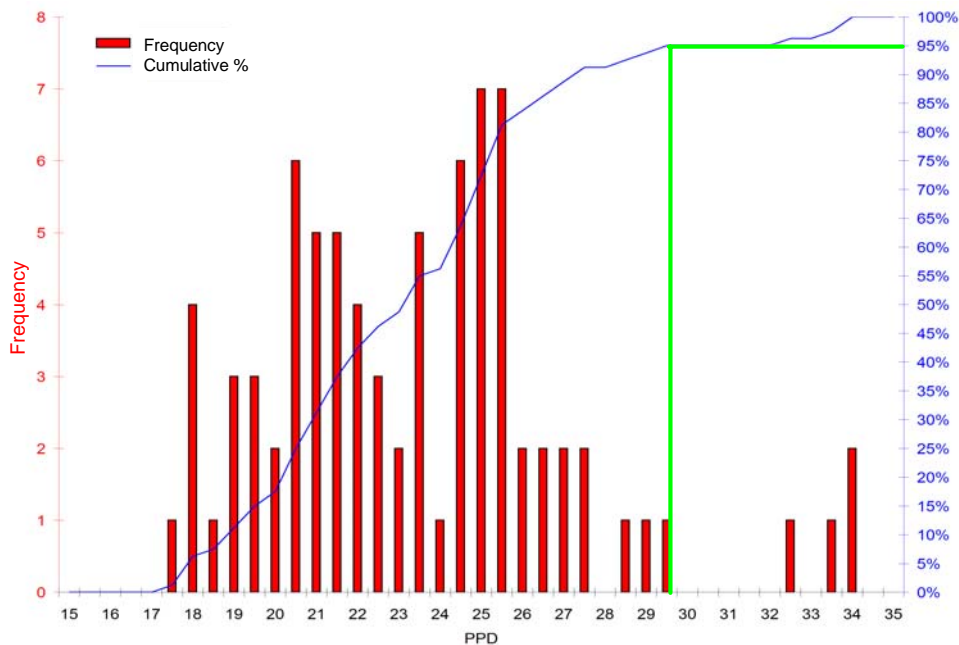

Frequency distribution (red vertical bars) and cumulative distribution function (thin blue curve) of Predicted Percentage of Dissatisfied (PPD) with the thermal comfort condition in the atrium. The thick green line shows the cumulative value of 95%, indicating that all other things being equal there is a probability of 95% of getting a PPD value lower than 30 for the investigated building design.

Comparison of reference calculation and uncertainty analysis. Results are presented directly in PPD as well as in hours of temperature above a certain predefined level. μ is the mean value and σ is the standard deviation.

	PPD (%)		Hours > 26 °C		Hours > 27 °C	
	μ	σ	μ	σ	μ	σ
Reference Calculation	29.8	-	213	-	131	-
Uncertainty analysis (17 parameters)	23.2	3.7	139	36	97	28

Benefits

The uncertainty analysis makes it possible to identify the most important parameters for building performance assessment and to focus the building design and optimization on these fewer parameters.

The results give a much better background for evaluation of the design than a single value (uncertainty quantified), which often is based on cautious selection of input parameters and therefore tends to underpredict the potential of passive technologies.

In many cases evaluation of a design solution is based on a calculation of the thermal comfort expressed by a performance indicator like PPD and/or the number of hours the temperature is higher than a certain value. Due to complexity of modelling of buildings and technical systems and the variation of boundary conditions and possible user scenarios, it is actually irresponsible to base decisions on a single calculation using a single sample of input parameters. An uncertainty analysis gives much more information about the performance and a much better background to make decisions.

Barriers

The main barrier for application of uncertainty analysis in building performance assessment is the increase in calculation time and complexity. Even if the Morris method is relative effective for screening analyses about 500 calculations are needed for an investigation of 50 variable input parameters.

Monte Carlo simulation is attractive for the uncertainty analysis, as the only requirement is that it is possible to describe the probability density function of the important input parameters. The disadvantage of the method is the high number of simulations. Even if an appropriate sampling procedure is selected the number of simulations to investigate the uncertainty is 2 – 5 times the number of parameters investigated with a total number of realizations not lower than 80 - 100.

Need for further research

Uncertainty analysis is far from being a central issue in consultancy. Explicit appraisal of uncertainty is the exception rather than the rule and most decisions are based on single valued estimates for performance indicators. At the moment experiences from practical design cases are almost nonexistent. These are needed to demonstrate the benefits and transform the methods to practice, i.e. include uncertainty analysis in commercially available building simulation tools.

Uncertainty analyses have a potential to be used to assess the robustness of different solutions to changes in boundary conditions and different user scenarios to avoid the design of very sensitive solutions. Methods and procedures for this purpose have to be developed.

The knowledge of typical variations of many input parameters is very limited. Material properties and characteristic parameter values of building components can only be estimated from tabular data and theoretical calculations. It is necessary to establish knowledge about the natural variability in properties of building components and materials as constructed in the built environment to improve the quality of the uncertainty analysis.

References

- Breesch, H. and Janssens, A. (2004). Uncertainty and Sensitivity Analysis of the Performances of Natural Night Ventilation, Proceedings of Roomvent 2004, 9th International Conference on Air Distribution in Rooms, Coimbra, Portugal, 5 – 8 September.
- Brohus, H. (2004). Performance Assessment of a Naturally Ventilated Multizone Building, Proceedings of CIB2004, CIB World Building Congress 2004, Toronto, Ontario, Canada, 1 – 7 May.
- Brohus, H. (2005). Uncertainty of IAQ Performance Assessment of a Naturally Ventilated Building, Proceedings of the 10th International Conference on Indoor Air Quality and Climate Indoor Air 2005, pp. 2854 – 2859, Beijing, China, September 4 – 9.
- Brohus H., Frier, C. and Heiselberg, P. (2002a). Stochastic Load Models based on Weather Data, Annex 35 Technical Report TR17, Department of Building Technology and Structural Engineering, Aalborg University, Aalborg, Denmark.
- Brohus H., Frier, C. and Heiselberg, P. (2002b). Stochastic Single Zone and Multizone Models of a Hybrid Ventilated Building – A Monte Carlo Simulation Approach, Annex 35 Technical Report TR19, Department of Building Technology and Structural Engineering, Aalborg University, Aalborg, Denmark.
- Hamby, D.M. (1994). A Review of Techniques for Parameter Sensitivity Analysis of Environmental Models, Environmental Monitoring and Assessment, Vol. 32, pp. 135 – 154.
- Iman, R.L. and Conover, W. J. (1982). A Distribution-Free Approach to Introducing Rank Correlation Among Input Variables. Commun. Statist. Simul. Comput. B 11, 311-334.
- Lam, J.C. and Hui, S.C.M. (1996). Sensitivity Analysis of Energy Performance of Office Buildings, Building and Environment, Vol. 31, No. 1, pp. 27 – 39.
- Lomas, K.J. and Eppel, H. (1992). Sensitivity Analysis Techniques for Building Thermal Simulation Programs, Energy and Buildings, Vol. 19, No. 1, pp. 21 – 44.
- Morris, M.D. (1991). Factorial Sampling Plans for Preliminary Computational Experiments, Technometrics, Vol. 33, No. 2, pp. 161 – 174.
- Saltelli, A., Chan, K., Scott, E. M. (2000a). Sensitivity Analysis. John Wiley & Sons. ISBN 047 1998 923.
- Saltelli, A., Tarantola, S. and Campolongo, F. (2000b). Sensitivity Analysis as an Ingredient of Modeling, Statistical Science, Vol. 15, No. 4, pp. 377-395.
- De Wit, M.S. (1997). Identification of the Important Parameters in Thermal Building Simulation Models, J. Statist. Comput. Simul., Vol. 57, pp. 305 – 320.

Published 2008 by
Aalborg University
Department of Civil Engineering
Sohngaardsholmsvej 57,
DK-9000 Aalborg, Denmark

ISSN 1901-726X
DCE Technical Report No. 049