



Aalborg Universitet

AALBORG UNIVERSITY  
DENMARK

## Single-User MIMO for LTE-A Uplink: Performance Evaluation of OFDMA vs. SC-FDMA

Maestro, Luis Angel; Berardinelli, Gilberto; Frattasi, Simone; Pajukoski, Kari; Mogensen, Preben Elgaard

*Published in:*  
Proceedings of IEEE Radio and Wireless Symposium

*Publication date:*  
2009

*Document Version*  
Publisher's PDF, also known as Version of record

[Link to publication from Aalborg University](#)

*Citation for published version (APA):*  
Maestro, L. A., Berardinelli, G., Frattasi, S., Pajukoski, K., & Mogensen, P. (2009). Single-User MIMO for LTE-A Uplink: Performance Evaluation of OFDMA vs. SC-FDMA. In Proceedings of IEEE Radio and Wireless Symposium (pp. 304-307). IEEE.

### General rights

Copyright and moral rights for the publications made accessible in the public portal are retained by the authors and/or other copyright owners and it is a condition of accessing publications that users recognise and abide by the legal requirements associated with these rights.

- ? Users may download and print one copy of any publication from the public portal for the purpose of private study or research.
- ? You may not further distribute the material or use it for any profit-making activity or commercial gain
- ? You may freely distribute the URL identifying the publication in the public portal ?

### Take down policy

If you believe that this document breaches copyright please contact us at [vbn@aub.aau.dk](mailto:vbn@aub.aau.dk) providing details, and we will remove access to the work immediately and investigate your claim.

# Single-User MIMO for LTE-A Uplink: Performance Evaluation of OFDMA vs. SC-FDMA

Luis Ángel Maestro Ruiz de Temiño #, Gilberto Berardinelli #, Simone Frattasi #,  
Kari Pajukoski \* and Preben Mogensen #

# Department of Electronic Systems, Aalborg University, Denmark

Email: {lam, gb, sf, pm}@es.aau.dk

\* Nokia-Siemens Networks, Oulu, Finland

Email: kari.pajukoski@nsn.com

**Abstract**— The 3rd Generation Partnership Project (3GPP) Long Term Evolution-Advanced (LTE-A) aims at very high peak data rates such as 1 Gbps in local areas and 100 Mbps in wide areas. To meet these targets, evolved multi-antenna techniques and large spectrum allocations are required. In this paper, we carry out a performance evaluation of uplink single-user multiple-input-multiple-output (SU-MIMO), both for orthogonal frequency division multiple access (OFDMA) and single-carrier frequency division multiple access (SC-FDMA) under LTE parameters. Different MIMO schemes such as single-input-multiple-output (SIMO), spatial multiplexing (SM) and transmit diversity with space-frequency coding (SFC) are investigated. Results show that OFDMA tends to outperform SC-FDMA for 2 receive antennas. However, this gap is reduced when 4 antennas are considered at the receiver. Furthermore, it is shown that the peak-to-average power ratio (PAPR) of the SC-FDMA signal is increased about 0.6 dB, when SFC is employed; nevertheless, a gain of 2 dB over OFDMA is still preserved.

**Index Terms**— LTE-A, MIMO, OFDMA, PAPR, SC-FDMA, spatial multiplexing, transmit diversity

## I. INTRODUCTION

The 3rd Generation Partnership Project (3GPP) is currently specifying the minimum requirements for Long Term Evolution-Advanced (LTE-A) systems, targeting peak data rates of 1 Gbit/s in local areas and 100 Mbit/s in wide areas. To cope with this ambitious requirements, advanced multiple-antenna techniques, providing high spectral efficiency values and very large spectrum allocations, in the order of 100 MHz, are expected to be deployed. In the previous LTE Release 8 standard [1], orthogonal frequency division multiple access (OFDMA) has been selected for the downlink due to its ability to easily cope with the frequency selectivity of wideband channels and its high spectral efficiency. In this scheme, the modulated symbols are split over low-rate narrowband orthogonal subcarriers and a proper cyclic prefix (CP) is inserted allowing simple equalization at the receiver [2]. However, due to the nature of the transmitted signal, in which the subcarriers can add in phase, OFDMA suffers from high peak-to-average power ratio (PAPR). This is particularly an issue for uplink

transmissions due to power consumption constraints in the mobile terminals. Therefore, single-carrier frequency division multiple access (SC-FDMA) was chosen for the uplink of LTE. This modulation scheme presents the same benefits in terms of multipath mitigation as OFDMA and it is characterized for its low PAPR properties [1]. However, it suffers from an effect called “noise enhancement”, which degrades its performance when linear receivers are used. Furthermore, by using an iterative approach based on turbo equalization [3], this performance degradation can be overcome at the expense of a higher computational complexity. Nevertheless, the selection of the most appropriate uplink access scheme for LTE-A is still under discussion. Furthermore, uplink single-user multiple-input-multiple-output (SU-MIMO) has not been standardized in LTE Release 8 but it is expected to be included in LTE-A to cope with the targeted data rates.

In this paper, we present a performance comparison of OFDMA vs. SC-FDMA for different open-loop multiple-antenna schemes such as single-input-multiple-output (SIMO), transmit diversity with space-frequency coding (SFC) based on the well-known Alamouti scheme and spatial multiplexing (SM) with single codeword configuration. These schemes have been widely treated in literature [4]-[5]-[6] and it is not our goal to deeply go into their principles. However, we evaluate their performance for LTE parameters bearing in mind their possible inclusion in the uplink of upcoming standards. The main goal is to obtain baseline results to provide a fair comparison between the access schemes and to investigate the feasibility of the previous MIMO schemes under realistic system assumptions. Previous work has been focused on the comparison of OFDMA vs. SC-FDMA for single-input-single-output (SISO) and SIMO with 2 receive antennas under ideal conditions [7]. We instead extend this study and relax those assumptions on a single-user scenario, where the number of receive antennas is shown to be a key parameter and non-ideal channel estimation is assumed amongst other constraints.

The rest of the article is organized as follows: in Section II, the considered LTE-A system is described as well as the MIMO schemes employed. The performance evaluation between access schemes is presented and discussed in Section III. Finally, Section IV concludes the work.

## II. SYSTEM MODEL

A simplified baseband MIMO OFDMA/SC-FDMA system is depicted in Fig. 1 with  $N_T$  transmit antennas and  $N_R$  receive antennas. On the transmitter side, the data bits are encoded, interleaved and mapped onto QPSK, 16QAM or 64QAM symbols yielding the vector  $\mathbf{d}$ . Then, a discrete Fourier transform (DFT) is performed in the case of SC-FDMA, spreading each data symbol over all the subcarriers, obtaining the vector  $\mathbf{s}$ . For OFDMA instead, each data symbol is mapped onto one subcarrier, i.e.,  $\mathbf{s} = \mathbf{d}$ . The complex symbols  $\mathbf{s}$  are then fed to the MIMO encoder block which performs spatial transformation of the input symbols giving as an output the encoded MIMO symbols  $\mathbf{x}$ . Next, pilot symbols are inserted in predefined positions to enable channel estimation at the receiver. Finally, an inverse fast Fourier transform (IFFT) is applied and CP is appended.

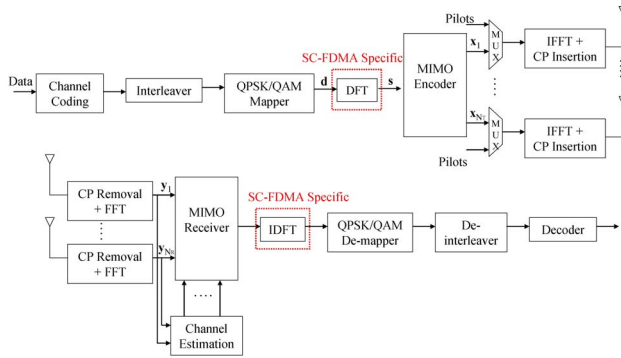

Fig. 1. Simplified OFDMA/SC-FDMA block diagram.

Assuming that the channel is static over the duration of an OFDMA symbol and that the CP is long enough to cope with the maximum delay of the multipath channel, the received signal after CP removal and fast Fourier transform (FFT) can be expressed as:

$$\mathbf{y}[k] = \mathbf{H}[k]\mathbf{x}[k] + \mathbf{w}[k] \quad (1)$$

where  $\mathbf{x}[k] = [x_1(k), x_2(k), \dots, x_{N_T}(k)]^T$  is a vector containing the encoded MIMO complex transmit symbols at subcarrier  $k$  from the  $N_T$  transmit antennas,  $\mathbf{w}[k] = [w_1(k), w_2(k), \dots, w_{N_R}(k)]^T$  is the additive white Gaussian noise vector with  $E[w_i(k)w_i(k)^*] = \sigma_w^2$  and

$$\mathbf{H}[k] = \begin{bmatrix} h_{11}(k) & \dots & h_{1N_T}(k) \\ \vdots & \ddots & \vdots \\ h_{N_R1}(k) & \dots & h_{N_RN_T}(k) \end{bmatrix} \quad (2)$$

is the channel transfer function matrix at subcarrier  $k$ .  $h_{ij}(k)$  denotes the complex channel gain from the transmit antenna  $j$  to the receive antenna  $i$ . In this study, it is assumed that  $E[s(k)s(k)^*] = 1$  and that the transmitted power is equally distributed among the transmit antennas.

The signal  $\mathbf{y}$  is fed to the MIMO receiver block which performs equalization of the received symbols to compensate for the amplitude and phase distortions introduced by the channel. To do so, an estimate of the channel transfer function is provided by the channel estimation block. The rest of the receiver chain performs the reversal operations of the transmitter side. Note that the inverse discrete Fourier transform (IDFT) is the responsible of the noise enhancement of SC-FDMA systems since the noise contribution of each subcarrier is spread over all symbols.

The next subsections will introduce the principles of the MIMO schemes considered in this work.

### A. SIMO

In this scheme there is only one transmit antenna. Hence, it can be written:

$$x_1(k) = s(k) \quad (3)$$

with  $k = 0, \dots, N_s - 1$ , being  $N_s$  the number of data symbols per OFDMA symbol. At the MIMO receiver block, maximal ratio combining (MRC) is performed for OFDMA [4] and minimum-mean-squared error (MMSE) equalization for SC-FDMA [8].

### B. SFC

For SFC, we consider Alamouti-based transmission on 2 antenna ports as suggested in 3GPP specifications [9]. If we only take the first block with subcarrier index 1 and 2 as example, the encoded MIMO vector  $\mathbf{x}$  is shown to be:

$$\begin{bmatrix} x_1(1) & x_1(2) \\ x_2(1) & x_2(2) \end{bmatrix} = \frac{1}{\sqrt{2}} \begin{bmatrix} s(1) & s(2) \\ -s(2)^* & s(1)^* \end{bmatrix} \quad (4)$$

At the receiver, the signals from different antennas are coherently added with the MRC principle assuming that the neighboring two subcarriers experience the same channel.

### C. SM

Finally, in this scheme the symbols  $s(k)$  are transmitted in parallel onto the different antennas to increase the spectral efficiency of the system. Therefore, it can be expressed:

$$x_j(k) = \frac{1}{\sqrt{N_T}} s(kN_T + j - 1) \quad (5)$$

with  $j$  denoting the transmit antenna index. In this case, MMSE detection is performed to mitigate the inter-stream interference [6].

TABLE I  
SIMULATION PARAMETERS

Sampling frequency	15.36 MHz
Subcarrier spacing	15 KHz
FFT size	1024
Used subcarriers	600
CP length	$5.2^a/4.68^b \mu s$
Slot duration	0.5 ms
Symbols per slot	7
MIMO schemes	(1x2, 1x4) SIMO; (2x2, 2x4) SFC; (2x2, 2x4) SM
User speed	3 kmph
MCS settings	QPSK: 1/6, 1/3, 1/2, 2/3 16QAM: 1/2, 2/3, 3/4 64QAM: 1/2, 2/3, 3/4

<sup>a</sup>First OFDMA/SC-FDMA symbol in a slot.

<sup>b</sup>2<sup>h</sup> – 7<sup>h</sup> OFDMA/SC-FDMA symbol in a slot.

### III. PERFORMANCE EVALUATION

In order to evaluate the performance of the previously introduced MIMO schemes for both OFDMA and SC-FDMA, 10 MHz LTE configuration parameters [9] are taken as a reference to run Monte Carlo simulations. These parameters are gathered in Table I as well as the modulation and coding scheme (MCS) formats employed. Realistic channel estimation based on robust Wiener filtering [10] is assumed. Furthermore, the considered channel coding is based on a rate 1/3 turbo encoder following 3GPP Release 8 specifications [11]. Results are presented for SCM-A channel model [12] in terms of link adaptation curves representing spectral efficiency (bits/s/Hz) vs. signal-to-noise ratio (SNR). These curves have been obtained by selecting the MCS which maximizes the average throughput for a given SNR point.

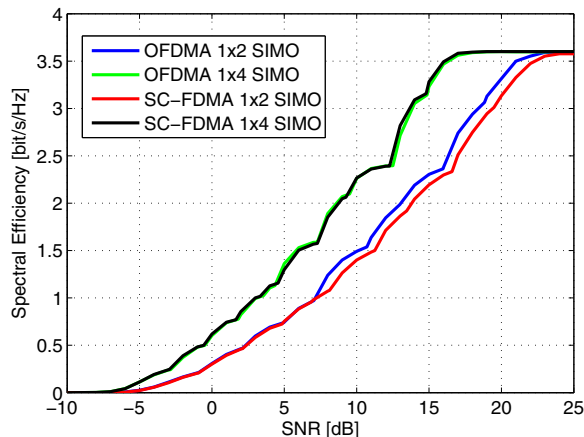

Fig. 2. SIMO results for SCM-A.

Fig. 2 depicts spectral efficiency results for SIMO configuration. It can be observed that the performance is highly leveraged for 4 receive antennas for both OFDMA and SC-FDMA. Furthermore, the 1 dB gap at medium-high SNR range between both access schemes for 1x2 configuration disappears when the number of receive antennas is set to 4. This is due to the increase of diversity branches, which averages the channel seen at the receiver. Extending the number of receive antennas will further smooth the deep fades of the channel, hence reducing the noise enhancement suffered by SC-FDMA and yielding the same performance for both access schemes. In Fig. 3, we present some results regarding transmit diversity with SFC. As for SIMO, there is a significant improvement when increasing the number of receive antennas. Moreover, for this MIMO scheme, OFDMA is shown to slightly outperform SC-FDMA with a gain of around 0.5 dB regardless the number of antennas at the receiver.

Regarding SM, spectral efficiency results are shown in Fig. 4. In the case of 2 receive antennas, OFDMA clearly outperforms SC-FDM with a gain of around 3 dB at high SNR. Here, we can easily see the effect of the noise enhancement on SC-FDMA, which severely degrades its performance compared to OFDMA. However, the gap between these access schemes is reduced to 0.5 dB when the receiver employs 4 antennas. Furthermore, we can appreciate that both access schemes perform similarly for low SNR range. Let us point out that the high spectral efficiency achieved by this MIMO scheme makes it a very attractive solution to achieve high peak data rates when favorable SNR conditions can be met.

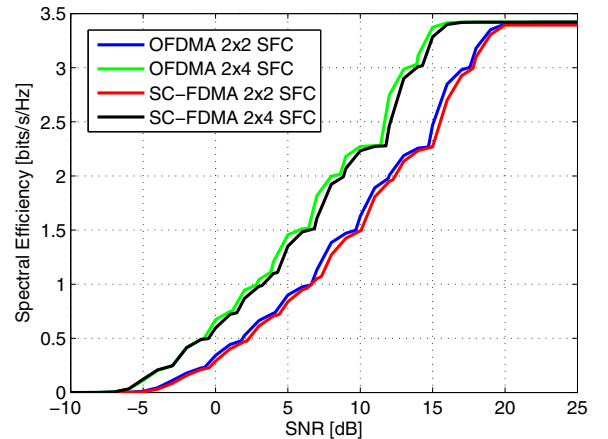

Fig. 3. SFC results for SCM-A.

Finally, some considerations regarding the PAPR of the transmitted signal must be done. Fig. 5 presents the complementary cumulative distribution function (CCDF) of the PAPR. As it can be seen, the PAPR of the SC-FDMA signal is increased by 0.6 dB with respect to the

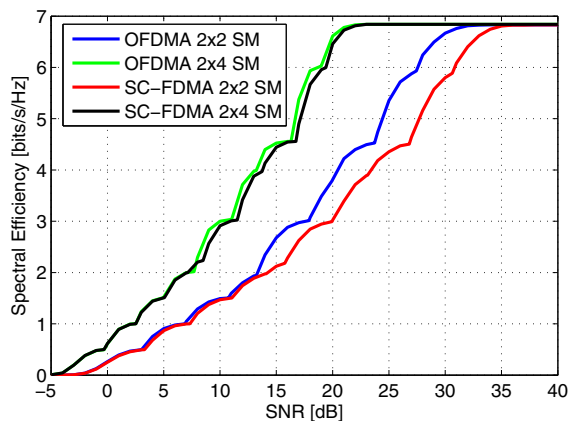

Fig. 4. SM results for SCM-A.

SISO case due to the SFC processing. However, there is still a gain of around 2 dB compared to OFDMA. Due to the particularities of the SFC scheme considered, this PAPR increase only affects the second transmit antenna since in the first one, the symbols are transmitted without any modification. Furthermore, there is not appreciative degradation in the case of OFDMA. For clarity only the PAPR of the SFC signal has been plotted.

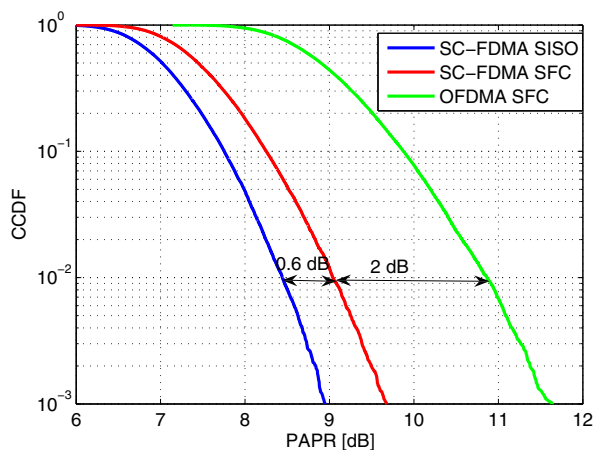

Fig. 5. PAPR of SC-FDMA for 16QAM.

#### IV. CONCLUSIONS

In LTE-A, SU-MIMO is expected to be introduced in uplink to cope with its ambitious data rate requirements. In this work, we have presented a performance comparison between OFDMA and SC-FDMA for different MIMO

schemes, which have been approved in the downlink of LTE. Specifically, SIMO, SFC and SM have been studied under realistic system assumptions. Results showed that, for 2 receive antennas, OFDMA outperforms SC-FDMA, especially for SM with a gain of 3 dB at high SNR. However, when the number of antennas at the receiver is increased up to 4, the gap between access schemes is highly reduced. Finally, it has been shown that there is a PAPR increase for SC-FDMA of 0.6 dB due to the spatial processing of SFC. This degradation is only appreciable in the second transmit antenna due to the considered SFC scheme. Nevertheless, a gain of 2 dB over OFDMA is still preserved.

As a future work, advanced non-linear receivers based on turbo equalization are to be investigated to boost SC-FDMA performance. It is expected that, with such a receiver, SC-FDMA will perform as good as OFDMA.

#### REFERENCES

- [1] "LTE Physical Layer - General Description (Release 8)," 3rd Generation Partnership Project, Tech. Rep. TS 36201, V8.1.0, Nov. 2007.
- [2] L. Hanzo, M. Munster, B. Choi, and T. Keller, *OFDM and MC-CDMA for Broadband MultiUser Communications, WLANs and Broadcasting*. John Wiley - IEEE Press, 2003.
- [3] G. Berardinelli, B. E. Priyanto, T. B. Sorensen, and P. Mogensen, "Improving SC-FDMA performance by turbo equalization in UTRA LTE uplink," *IEEE Vehicular Technology Conference*, pp. 2557–2561, May 2008.
- [4] T. Lo, "Maximum ratio transmission," *IEEE Transactions on Communications*, vol. 47, no. 10, pp. 1458–1461, Oct 1999.
- [5] S. Alamouti, "A simple transmit diversity technique for wireless communications," *IEEE Journal on Selected Areas in Communications*, vol. 16, no. 8, pp. 1451–1458, Oct 1998.
- [6] P. Wolniansky, G. Foschini, G. Golden, and R. Valenzuela, "V-BLAST: an architecture for realizing very high data rates over the rich-scattering wireless channel," *URSI International Symposium on Signals, Systems and Electronics*, pp. 295–300, Oct 1998.
- [7] B. Priyanto, H. Codina, S. Rene, T. Sorensen, and P. Mogensen, "Initial performance evaluation of DFT-spread OFDM based SC-FDMA for UTRA LTE uplink," *IEEE 65th Vehicular Technology Conference, VTC2007-Spring*, pp. 3175–3179, April 2007.
- [8] D. Falconer, S. Ariyavisitakul, A. Benyamin-Seeyar, and B. Eidson, "Frequency domain equalization for single-carrier broadband wireless systems," *IEEE Communications Magazine*, vol. 40, no. 4, pp. 58–66, Apr 2002.
- [9] "Evolved Universal Terrestrial Radio Access (E-UTRA); Physical Channels and Modulation," 3rd Generation Partnership Project, Tech. Rep. TS 36.211, V8.1.0, Nov. 2007.
- [10] O. Edfors, M. Sandell, J. van de Beek, and S. Wilson, "OFDM channel estimation by singular value decomposition," *IEEE Transactions on Communications*, vol. 46, no. 7, pp. 931–939, July 1998.
- [11] "Evolved Universal Terrestrial Radio Access (E-UTRA); Multiplexing and channel coding," 3rd Generation Partnership Project, Tech. Rep. TS 36.212, V8.1.0, Nov. 2007.
- [12] "Physical layer aspects for evolved Universal Terrestrial Radio Access (UTRA)," 3rd Generation Partnership Project, Tech. Rep. TR 25.814, V7.1.0, 2006.