



Aalborg Universitet

AALBORG UNIVERSITY
DENMARK

Improving SC-FDMA performance by Turbo Equalization in UTRA LTE Uplink

Berardinelli, Gilberto; Priyanto, Basuki Endah; Sørensen, Troels Bundgaard; Mogensen, Preben Elgaard

Published in:

I E E V T S Vehicular Technology Conference. Proceedings

DOI (link to publication from Publisher):

[10.1109/VETECS.2008.562](https://doi.org/10.1109/VETECS.2008.562)

Publication date:

2008

Document Version

Publisher's PDF, also known as Version of record

[Link to publication from Aalborg University](#)

Citation for published version (APA):

Berardinelli, G., Priyanto, B. E., Sørensen, T. B., & Mogensen, P. (2008). Improving SC-FDMA performance by Turbo Equalization in UTRA LTE Uplink. I E E V T S Vehicular Technology Conference. Proceedings, 2557-2561. DOI: 10.1109/VETECS.2008.562

General rights

Copyright and moral rights for the publications made accessible in the public portal are retained by the authors and/or other copyright owners and it is a condition of accessing publications that users recognise and abide by the legal requirements associated with these rights.

- ? Users may download and print one copy of any publication from the public portal for the purpose of private study or research.
- ? You may not further distribute the material or use it for any profit-making activity or commercial gain
- ? You may freely distribute the URL identifying the publication in the public portal ?

Take down policy

If you believe that this document breaches copyright please contact us at vbn@aub.aau.dk providing details, and we will remove access to the work immediately and investigate your claim.

Improving SC-FDMA Performance by Turbo Equalization in UTRA LTE Uplink

Gilberto Berardinelli, Basuki E. Priyanto, Troels B. Sørensen, Preben Mogensen

Department of Electronic Systems, Aalborg University

Niels Jernes Vej 12, DK-9220 Aalborg East, Denmark

Email: {gb, bep, tbs, pm}@es.aau.dk

Abstract—Turbo equalization is known as an advanced iterative equalization and decoding technique that allows to enhance the performance of the data transmission over a frequency selective fading channel. The turbo equalizer will result in extra receiver complexity, but isolated to the base-station, which does not have stringent power constraints. In this paper, a turbo equalization technique to improve Single Carrier Frequency Division Multiple Access (SC-FDMA) performance is proposed. A new adaptive coefficients solution for frequency domain equalization is considered. The work is in the context of UTRA Long Term Evolution (LTE) Uplink. The performance is evaluated for 1x2 Single Input Multiple Output (SIMO) antenna configuration in a 6 paths Typical Urban (TU-06) channel profile. For assessment purpose, the results are compared with SC-FDMA MMSE and OFDMA schemes. Simulation results show that the turbo equalizer can improve the BLER performance around 1 dB with only a few iterations, and improve the SC-FDMA performance over OFDM, especially at high coding rate.

Index Terms - OFDM, SC-FDMA, Uplink, Turbo Equalization, UTRA LTE

I. INTRODUCTION

UTRA Long Term Evolution (LTE) [1] is introduced to ensure the competitiveness of UMTS system in the upcoming years. The objective is to obtain high data rate, low latency, and packet optimized radio access technology [2]. The target uplink peak data rate is 50 Mbps in 20 MHz system bandwidth. In 3GPP UTRA LTE Study Item, Single Carrier Frequency Division Multiple Access (SC-FDMA) has been selected for the uplink radio access technology. SC-FDMA is preferred for uplink transmission over OFDMA because of the lower Peak-to-Average Power Ratio (PAPR) property of SC-FDMA signals [3]. It results in more efficient power amplification in the user equipment (UE).

The performance results in our previous study [4] show that the OFDMA performance is generally better than SC-FDMA. The aim of this work is to propose a turbo equalization suitable for SC-FDMA and evaluate the performance. The performance gain is obtained by adding complexity at the receiver. The principal operation of the turbo equalization is an iterative process, in which feedback information obtained from the decoder is incorporated into the equalization process. In that way the performance is improved through an iterative exchange of extrinsic information between the equalizer and the decoder. The iterative processing allows for reduction of the intersymbol interference (ISI), multistream interference, and noise.

Turbo equalization (TEQ) was originally proposed by Douillard et al. [5] with the purpose of mitigating the effects of inter-symbol interference using an MLSE (Maximum Likelihood Sequence Estimation) equalizer. Tuchler [6] proposed the turbo equalization based on both MMSE (Minimum Mean Square Error) and DFE (Decision Feedback Equalization) equalizer with the advantage of reducing the receiver complexity. Combined turbo coding equalization and decoding has been studied in [7], whereas in [8], turbo equalization has been extended for multi-level modulation schemes. In all of these papers, the equalization is performed in the time domain. Tuchler et al. proposed a frequency domain equalizer with fixed coefficients solution, and with lower complexity [9].

The proposed turbo equalization in this paper follows the principles explained in [10], but the equalization is performed through a frequency domain soft interference cancellation (SIC) equalizer [11]. The novelty part is to use adaptive coefficients for the equalization, which are recalculated at each iteration.

The paper is outlined as follows. In section II, the SC-FDMA basic transmitter operation is presented. The turbo equalization scheme at the SC-FDMA receiver is described in section III. In section IV, the derivation of the forward and feedback coefficients for the turbo equalization processing are presented. The simulation results for various modulation and coding rate and the performance comparison with the OFDM and SC-FDMA MMSE are presented in section V. Finally, the conclusions are drawn in section VI.

II. SC-FDMA TRANSMITTER

The SC-FDMA transmitter structure is shown in Fig.1. A frame of information bits u_i is encoded by a turbo encoder. The coded bits b_l are interleaved by using a random permutation function [12]. The interleaved and coded bits b_m are grouped in N q -length blocks $\{[b_{1,1}, \dots, b_{1,q}], \dots, [b_{N,1}, \dots, b_{N,q}]\}$. Each block is mapped to a complex symbol s^i , $i=1, \dots, M$, where $M = 2^q$ is the number of symbols of the considered constellation. The SC-FDMA transmitter structure is almost identical to OFDM [1]. It has an additional Discrete Fourier Transform (DFT) spreading operation performed after the M-PSK or M-QAM symbol sequence s_n . The output of the DFT spreading is given by:

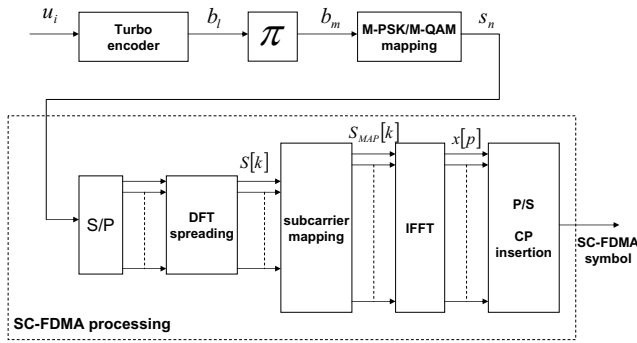

Fig. 1. SC-FDMA transmitter

$$S[k] = \frac{1}{N} \sum_{n=0}^{N-1} s_n e^{-\frac{j2\pi kn}{N}} \quad k = 0, \dots, N-1 \quad (1)$$

where N is the number of useful subcarriers.

This operation spreads the symbol sequence over all the subcarriers, so that each subcarrier takes information of the entire symbol sequence. Spread symbol sequences are mapped to the assigned subcarriers (S_{MAP}) for transmission [4]. Finally, the data is OFDM-processed by an IFFT block and the output is given by:

$$x[p] = \sum_{k=0}^{N_{FFT}-1} S_{MAP}[k] e^{\frac{j2\pi kp}{N_{FFT}}} \quad p = 0, \dots, N_{FFT}-1 \quad (2)$$

where N_{FFT} is the FFT size. A cyclic prefix (CP) is added [13], with the purpose of eliminating the intersymbol interference (ISI) caused by the time dispersive channel.

III. TURBO EQUALIZATION

Considering that the frequency selective channel can be regarded as an encoder serially concatenated with the transmitter channel encoder, the main idea of the turbo equalization is to perform joint equalization/demodulation and decoding operations at the receiver [10]. In this case, equalizer and decoder are considered as soft input/soft output blocks, separated by the bit-deinterleavers and bit-interleavers. The information produced by one of these blocks can be treated as an a priori information for the other one. The purpose of this operation is to produce a more reliable estimation of the transmitted symbol sequence in each iteration. It is obtained through the progressive reduction of the interference component and the knowledge of the coded words structure given by the decoder.

The block diagram of our turbo equalizer receiver is shown in Fig. 2. It uses a soft interference cancellation (SIC) equalizer as described in [11] and a frequency domain equalization. This

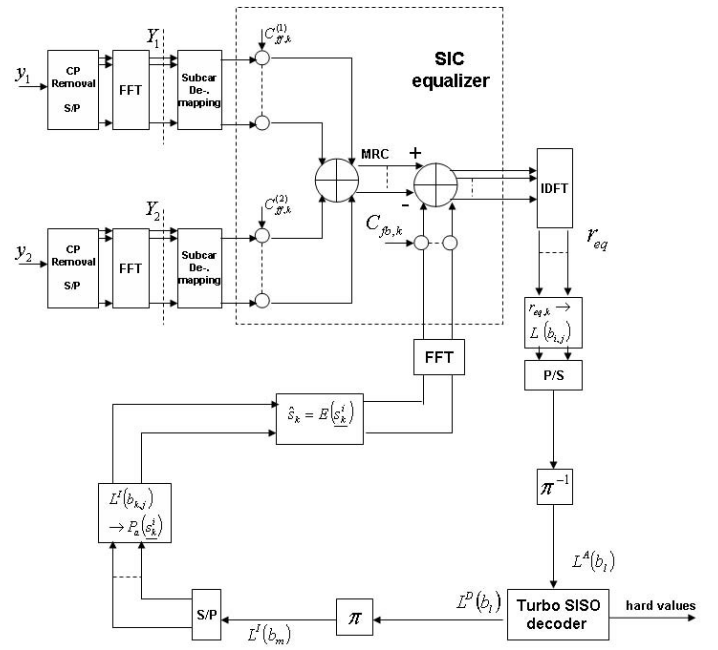

Fig. 2. Turbo equalizer structure

structure results in more efficient operation than the traditional time domain equalization [9], since the equalization is performed on a data block at a time. Moreover, the operations on this block involve an efficient FFT operation and a simple channel inversion operation.

In our study, we consider the two receive antennas (1x2 SIMO) case. After the CP removal and FFT operation, the received signal at each antenna can be written as:

$$\mathbf{Y}_1 = \mathbf{X} \cdot \mathbf{H}_1 + \mathbf{w}_1 \quad (3)$$

$$\mathbf{Y}_2 = \mathbf{X} \cdot \mathbf{H}_2 + \mathbf{w}_2 \quad (4)$$

where \mathbf{X} is the diagonal matrix of the transmitted sub-carrier symbols, \mathbf{H}_1 and \mathbf{H}_2 are the vectors of channel frequency responses for the two antennas, and \mathbf{w} is the noise component vector.

Then, a frequency domain equalization with a simple one tap equalizer is performed to compensate the amplitude and phase distortions of the received signals. The equalizer coefficients are indicated as the forward coefficients ($C_{ff}^{(1)}, C_{ff}^{(2)}$), and these will be discussed in the next section. Then the signals from both paths are simply added Maximal Ratio Combining (MRC), and the resultant signal is converted to the time domain through an IDFT operation. The output is the estimation of the transmitted M-PSK or M-QAM symbols.

The IDFT operation spreads the noise contribution of all the individual subcarriers on all the samples in time domain: this noise enhancement is the main reason for degradation of SC-FDMA performance compared to OFDMA.

Note that each symbol s^i of the constellation diagram is associated to a known sequence of bits of length q . The log-likelihood ratios of all the coded bits [14] are approximated by:

$$L(b_{i,j}) \approx \left(\min_{\epsilon_k^i: b_{i,j}=-1} \epsilon_k^i - \min_{\epsilon_k^i: b_{i,j}=1} \epsilon_k^i \right) \quad (5)$$

where $b_{i,j}$ is the j^{th} bit associated with the constellation point s^i , k is the index of the transmitted symbol, and ϵ_k^i denotes the squared euclidean distance of the equalizer output to s^i , defined as:

$$\epsilon_k^i = |r_{eq,k} - s^i|^2 \quad (6)$$

where $r_{eq,k}$ is the SIC equalizer output after the IFFT operation.

The log-likelihood ratios of all coded bits $L^A(b_l)$, obtained from (5) after the parallel-to-serial and the deinterleaving operations, are submitted to the turbo decoder. The turbo decoder exploits a *soft* operation instead of its traditional hard detection task: it computes an improved log-likelihood ratio of all coded bits $L^D(b_l)$, taking into account the knowledge of the encoder scheme. This soft output has been obtained modifying the structure of each Maximum A Posteriori (MAP) decoder inside the turbo decoder structure [15], applying the BCJR algorithm [16] at both the systematic and the parity bits [7]. After the interleaving operation, the resulting $L^I(\cdot)$ are grouped in q -length blocks and defined as:

$$\{ [L^I(b_{1,1}), \dots, L^I(b_{1,q})], \dots, [L^I(b_{N,1}), \dots, L^I(b_{N,q})] \}. \quad (7)$$

In this way, a $(N \times q)$ matrix having in each row the log-likelihood ratios of the bits related to each transmitted symbol is obtained. The probability of each bit is computed as follows:

$$P_e(b_{k,j} = 0) = \frac{1}{1 + \exp(L_a^E(b_{k,j}))}; \quad (8)$$

$$P_e(b_{k,j} = 1) = 1 - P_e(b_{k,j} = 0). \quad (9)$$

Thus, it is possible to compute the $(N \times M)$ apriori symbol probability matrix $[P_a(s_k^i)]$, whose generic element is defined as follows:

$$P_a(s_k^i) = P(s_k = s^i) = \prod_{j=1}^q P_e(b_{k,j} = b_{i,j}) \quad (10)$$

for $k=1, \dots, N$ and $i=1, \dots, M$, where s_k is the k -th symbol of the transmitted sequence.

From each row of this matrix, the estimation of the transmitted symbol vector can be computed:

$$\hat{s}_k = E(s_k^i) = \sum_{i=1}^M s^i P_a(s_k^i) \quad (11)$$

The estimated sequence is then converted to frequency domain through an FFT operation and multiplied with the feedback coefficients (C_{fb}), in order to extract the interference component from it. This interference component is then subtracted from the equalized vector.

The turbo equalizer exploits the described tasks for a number of iterations; after that, the turbo decoder takes hard decisions about the transmitted bits.

The computational complexity of the turbo equalizer processing is mostly related to the computation of the $(N \times M)$ apriori symbol probability matrix, that should be recomputed at each iteration of the algorithm.

IV. SIC EQUALIZER COEFFICIENTS

The key issue affecting the performance of the turbo equalizer is the proper derivation of the forward and feedback coefficients of the SIC equalizer. The forward coefficient C_{ff} should be computed with the purpose of increasing the signal to noise ratio and obtaining a good estimation of the transmitted symbols. The feedback coefficients C_{fb} should be computed with the purpose of cancelling the interference component in the estimated symbol vector. Instead of using the traditional fixed frequency domain SIC coefficients as defined in [9], we use an adaptive solution where the coefficients are updated at each iteration of the algorithm. The main idea is to update the coefficients depending on the variance of the estimated symbol vector \hat{s}_k . The equalizer forward coefficients are computed as follows:

$$C_{ff,k}^{(1)} = \frac{\sigma_s^2}{1 + \beta \sigma_s^2 (\sigma_s^2 - \sigma_s^2)} \frac{H_{1,k}^*}{(|H_{1,k}|^2 + |H_{2,k}|^2) + \frac{\sigma_w^2}{\sigma_s^2}} \quad (12)$$

$$C_{ff,k}^{(2)} = \frac{\sigma_s^2}{1 + \beta \sigma_s^2 (\sigma_s^2 - \sigma_s^2)} \frac{H_{2,k}^*}{(|H_{1,k}|^2 + |H_{2,k}|^2) + \frac{\sigma_w^2}{\sigma_s^2}} \quad (13)$$

where $\frac{\sigma_w^2}{\sigma_s^2}$ is the noise-to-signal ratio, σ_s^2 is the variance of the transmitted symbols, σ_s^2 is the variance of the estimated symbols. β is defined as:

$$\beta = \frac{1}{N} \sum_{k=1}^N \frac{|H_{1,k}|^2 + |H_{2,k}|^2}{(\sigma_s^2 - \sigma_s^2) (|H_{1,k}|^2 + |H_{2,k}|^2) + \frac{\sigma_w^2}{\sigma_s^2}} \quad (14)$$

N is the length of the channel frequency response vector. For analytical derivation of (12) and (13) we refer to [17], where a similar approach has been used for the time domain equalization.

At the first iteration, we assume $\sigma_s^2 = 0$ because no apriori information is available. The forward coefficients perform as the traditional MMSE coefficients [18]. For the next iterations, the estimation of the transmitted symbols becomes more accurate, $\sigma_s^2 \approx \sigma_s^2$. The feedback coefficients are given by:

$$C_{fb,k} = H_{1,k} C_{ff,k}^{(1)} + H_{2,k} C_{ff,k}^{(2)} - 1. \quad (15)$$

It can be shown that feedback coefficients are defined in condition where the estimated symbol sequence is very accurate ($\sigma_s^2 \approx \sigma_s^2$), the resultant interference component becomes very small. Using these adaptive coefficients, the obtained vector after the multiplication with the forward coefficients changes at each iteration, and get closer to the

TABLE I
UTRA LTE UPLINK SIMULATION PARAMETERS.

Parameter	Value
Carrier Frequency	2 GHz
Transmission BW	10 MHz
Sub-frame duration	0.5 ms
Sub-carrier spacing	15 kHz
SC-FDM symbols per sub-frame	6 LBs, 2 SBs
CP duration	4.1 μ s
Useful subcarriers/FFT size	600/1024
Useful subcarriers	600
MCS settings	BPSK: 1/6, 1/3 QPSK: 1/2, 2/3, 3/4 16QAM: 1/2, 2/3, 3/4, 4/5
Channel code	3GPP Rel. 6 compliant Turbo code with basic rate 1/3
Turbo decoder Iterations	8
Interleaver	3GPP Rel. 6
Channel Estimation	Ideal
Antenna schemes	1x2 SIMO
Channel model	Typical Urban 6 paths [19]
Receiver Scheme	MMSE TEQ
Speed	3 kmph

transmitted vector as the estimated interference component decreases.

V. SIMULATION RESULTS

A computer simulation is carried out to evaluate our proposed turbo equalizer technique. The simulation settings and parameters are following the UTRA LTE Uplink context given in Table I. For details on the link level processing we refer to [4]. During the simulation, we have the following assumption:

- One subframe in uplink consists of 6 long blocks (LBs) and 2 short blocks (SBs) [1]. LBs are used for data transmission, whereas SBs are used for reference signals for coherent demodulation and/or control/data transmission;
- ideal channel estimation;
- the maximum excess delay of the frequency selective fading channel is shorter than the CP duration.

Fig. 3 shows the BLER (Block Error Rate) performances of the SC-FDMA 16 QAM system with three different coding rates. The main purpose is to demonstrate the impact of turbo equalizer on the link level performance. The results of TEQ with different iterations and SC-FDMA with simple MMSE are given. Two different results for turbo equalization are shown, obtained, respectively, with 2 and 4 iterations of the algorithm. Compared with the MMSE receiver, the turbo equalizer shows a gain of around 1 dB. In our assumptions, the cyclic prefix allows complete removal of the ISI, hence the gain is exclusively due to the reduction of the noise component. The significant gain is already obtained from 2 iterations of the algorithm.

In Fig. 4 the performance of OFDMA has also been included, and the results are shown for both QPSK and 16 QAM modulation systems. The aim is to compare with the SC-FDMA TEQ receiver performance for 2 iterations of the

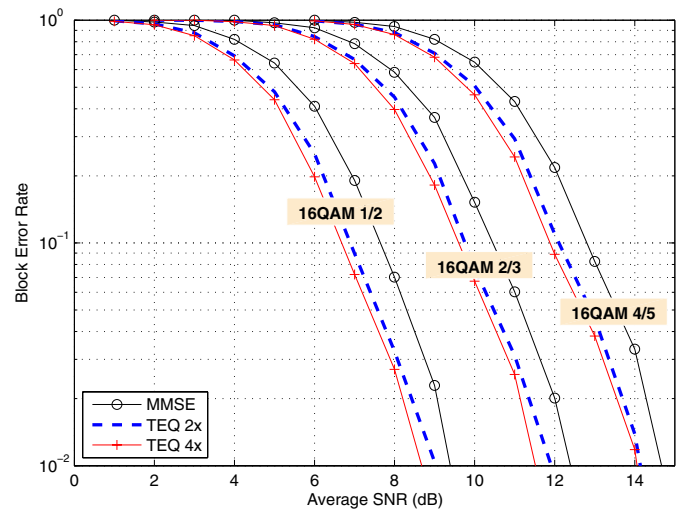

Fig. 3. BLER Performance for SC-FDMA 1x2 MRC with and without Turbo Equalizer in TU 06 channel.

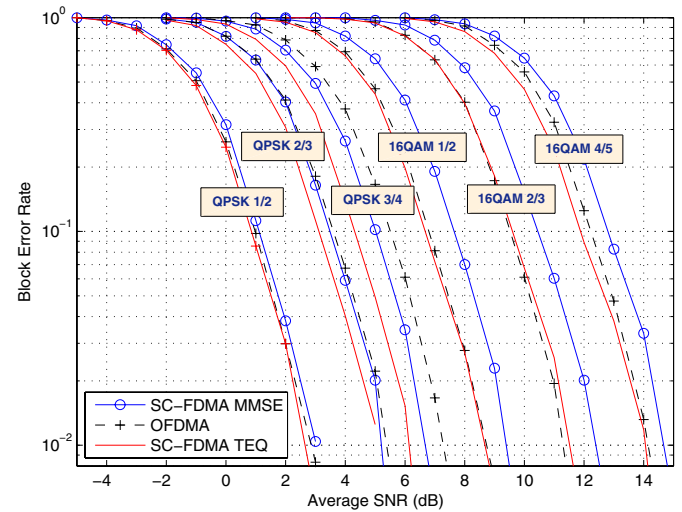

Fig. 4. BLER Performance for SC-FDMA versus OFDMA in TU 06 channel.

algorithm. Note that, for QPSK 2/3 and QPSK 3/4, the SC-FDMA MMSE system performs better than OFDMA. This is due to the fact that low order modulation schemes are much robust to the noise enhancement of SC-FDMA transmission. Moreover, OFDM transmission is more sensitive to the coding rate than SC-FDMA [13]. SC-FDMA takes advantage of spreading the data symbols over the transmission bandwidth, since the effect of a deep fading affecting few subcarriers will be diminished in the receiver combining all the subcarriers information. The receiver with turbo equalizer gives better performance in most of the cases, and in the worst case it shows the same performance as OFDMA.

Therefore, turbo equalizer allows to reduce the noise enhancement due to the time domain transmission in the SC-FDMA system, and makes performance the same or better than OFDMA. The gain depends mostly on the usage of equalizer

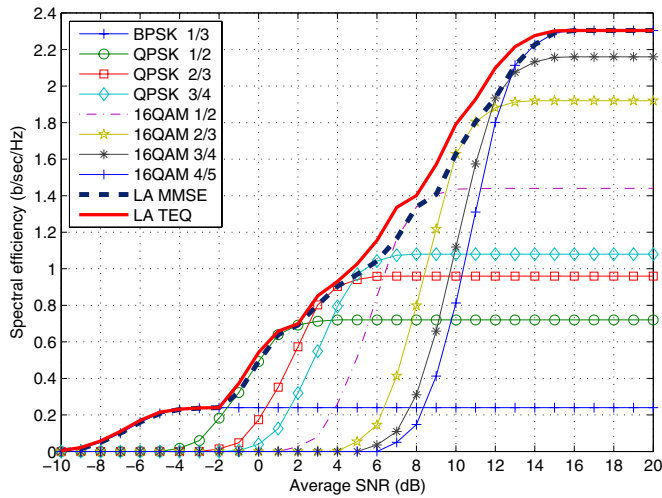

Fig. 5. Spectral efficiency for 1x2 MRC SC-FDMA in TU 06 channel.

with adaptive coefficients.

The performance results for several MCS (Modulation Coding Scheme) in terms of spectral efficiency are shown in Fig. 5. The figure shows the Link Adaptation (LA) curve for both the MMSE and the TEQ receiver. Here, the link adaptation is defined as the maximum achievable spectral efficiency for various MCS schemes versus the average SNR. It is shown that the turbo equalization is effective for higher order MCS, whereas for BPSK it does not show any performance improvement. Therefore, in order to exploit its performance gain, the turbo equalizer receiver could be used for high order modulation schemes, whereas the simple MMSE receiver can still be used for BPSK. In this way, the computation time for low order modulations can be further reduced.

VI. CONCLUSIONS

In this paper, a turbo equalizer suitable for SC-FDMA in UTRA LTE Uplink is proposed and evaluated. A 1x2 SIMO case is considered in this study. The aim of the proposed turbo equalizer is to enhance the performance of the SC-FDMA system, so that it performs better than OFDMA.

Despite of an increase of the receiver complexity in the base station, the turbo equalizer can reduce the noise enhancement in SC-FDMA system. Results show that a turbo equalizer receiver for SIMO system can improve the BLER performance by almost 1 dB compared to a traditional MMSE receiver. Most of the performance gain is obtained with 2 iterations of the algorithm. The gain is mostly obtained from the usage of equalizer with adaptive coefficients. In our case, both forward and feedback coefficients are updated at each iteration. Furthermore, the simulation results show that the SC-FDMA turbo equalizer performance is better or equal to OFDMA for all the modulation and coding schemes. Link Adaptation curves show that the turbo equalizer gain becomes effective

for high order modulation schemes, especially for high coding rates. Therefore, the turbo equalizer is especially advantageous in a high SNR scenario.

Our future work will address an extension of the SC-FDMA turbo equalizer to the MIMO antenna scheme. Here, the iterative process allows for reduction of the multistream interference, and a significant gain from the usage of the turbo equalizer is expected.

ACKNOWLEDGMENT

The authors wish to thank Carles Navarro Manchon for his helpful comments and fruitful discussions.

REFERENCES

- [1] 3GPP TR 25.814 V1.4.0 (2006-05), "Physical Layer Aspects for Evolved UTRA".
- [2] 3GPP TR 25.913 V7.3.0 (2006-03), "Requirements for Evolved UTRA (E-UTRA) and Evolved UTRAN (E-UTRAN)".
- [3] J. Tubbx, et al., "OFDM Versus Single Carrier With Cyclic Prefix: A System-Based Comparison", in *Proc. 54th IEEE Vehicular Technology Conference*, vol. 2, Atlantic City, NJ, USA, pp.1115-1119, October 2001.
- [4] B. E. Priyanto, et al., "Initial Performance Evaluation of DFT-Spread OFDM Based SC-FDMA for UTRA LTE Uplink", in *IEEE 65th Vehicular Technology Conference*, nr.65, Dublin, Ireland, Apr. 2007.
- [5] C. Douillard et al., "Iterative correction of intersymbol interference: Turbo equalization", *European Trans. on Telecomm.*, vol.6, pp.507-511, Sept. 1995.
- [6] Micheal Tuchler, et al., "Turbo Equalization: Principles and New Results". *IEEE Transactions on Communications*, vol.50, no.5, May 2002.
- [7] D. Raphaeli, Y. Zarai, "Combined turbo equalization and turbo decoding", *IEEE Communications Letters*, vol.2, no.4, pp. 107-109, Apr.1998.
- [8] A. Dejonghe, L. Vanderdorpe, "Turbo-equalization for multilevel modulation: an efficient low-complexity scheme", *IEEE International Conference on Communications*, vol.3, pp.1863-1867, May 2002.
- [9] M. Tuchler, J. Hagenauer, "Turbo equalization using frequency domain equalizers", in *Proc. Allerton Conference*, Monticello, AR, USA, p. 144153, Oct. 2000.
- [10] R. Koetter, et al., "Turbo equalization", *IEEE Signal Processing Mag.*, vol.21, no.1, pp.67-80, Jan. 2004.
- [11] C. Laot, et al., "Turbo equalization: adaptive Equalization and Channel Decoding Jointly Optimized", *IEEE Journal on Sel. Areas in Communs*, vol.19, no.9, Sept. 2001.
- [12] 3GPP TR 25.212 V6.5.0(2005-2006), "Multiplexing and channel coding".
- [13] D. Falconer, et al., "Frequency domain equalization for single-carrier broadband wireless systems," *IEEE Commun. Mag.*, vol. 40, no. 4, pp. 5866, Apr. 2002.
- [14] B. Sklar, "A primer on turbo code concepts", *IEEE Communication Mag.*, vol. 35, no. 12, pp. 94101, Dec. 1997.
- [15] W. E. Ryan, "A Turbo Code Tutorial", New Mexico State University, Box 30001 Dept. 3-0, Las Cruces, MN 88003, <http://www.ece.arizona.edu/ryan/>.
- [16] C. Berrou, et al., "Near Shannon limit error-correcting coding and decoding: Turbo Codes", in *Proc. 1993 Int. Conf. Comm.*, Geneva, Switzerland, pp.1064-1070, May 1993.
- [17] C. Laot, et al., "Low-Complexity MMSE Turbo Equalization: A Possible Solution for EDGE", *IEEE Transactions on Wireless Communications*, vol.4, no.3, May 2005.
- [18] H. Sari, G. Karam, and I. Jeanclaude, "Frequency-domain equalization of mobile radio and terrestrial broadcast channels," in *Proc. IEEE Global Telecommun. Conf.*, vol. 1, Nov. 1994.
- [19] 3GPP TR 25.943, "Deployment aspects".