



AALBORG UNIVERSITY
DENMARK

Aalborg Universitet

Protection Coordination Based on a Multi-agent for Distribution Power System with Distribution Generation Units

Chen, Zhe; Kong, Wei

Publication date:
2007

Document Version
Publisher's PDF, also known as Version of record

[Link to publication from Aalborg University](#)

Citation for published version (APA):

Chen, Z., & Kong, W. (2007). Protection Coordination Based on a Multi-agent for Distribution Power System with Distribution Generation Units. Paper presented at International Workshop on Next Generation Regional Energy System Development, Seoul, .

General rights

Copyright and moral rights for the publications made accessible in the public portal are retained by the authors and/or other copyright owners and it is a condition of accessing publications that users recognise and abide by the legal requirements associated with these rights.

- ? Users may download and print one copy of any publication from the public portal for the purpose of private study or research.
- ? You may not further distribute the material or use it for any profit-making activity or commercial gain
- ? You may freely distribute the URL identifying the publication in the public portal ?

Take down policy

If you believe that this document breaches copyright please contact us at vbn@aub.aau.dk providing details, and we will remove access to the work immediately and investigate your claim.

Protection Coordination Based on Multi-agent for Distribution Power System with Distribution Generation Units

*Z. Chen, and **W. Kong

¹Abstract--The penetration of DGs would drastically affect the traditional distribution power system fault current level and the characteristics of fault currents, consequently, the traditional protection arrangements developed in radial systems are difficult in coordination, and also the reclosing scheme would be affected. With the rapid developments in distribution system automation and communication technology, the protection coordination and reclosing scheme based on information exchange for distribution power system can be realized flexibly. A protection coordination mode based on multi-agent technology is discussed in this paper.

Index Terms--Distribution power system, Distributed Generation Units, Protection Coordination, Multi-agent technology

I INTRODUCTION

The traditional power systems, which are based on large fossil fuel fired power generation plants, long distance transmission lines and hierarchical control centres, are changing. A large number of dispersed generation (DG) units, including renewable energy sources such as wind turbines, PV generators, fuel cells together with Combined Heat and Power (CHP) plants, are being integrated into power systems at distribution level. For example, the decentralised power plants, including wind turbines, cover up about 40% of the total production capacity in Danish power systems. The use of DG units, especially renewable energy source based DGs, are driven by the growing concern over the environmental pollution and the increased internationalisation and liberalization of the electricity market. The use of renewable sources is promoted to meet environmental goals and provide long-term energy supplies. The liberalization of the electricity

market provides the opportunity for investors to install various types of renewable energy based DG units. The energy, being produced locally near the load, can also reduce the losses from the power transmission and distribution. On the other hand, the large number of the renewable based DG integrated into the power market also presents a great number of challenges. The introduction of renewable energy based DG units affects the network economically and technically in a number of ways. The power electronic converters, which are used for interfacing most of renewable generation units, fuel cells and energy storage devices, may present very different characteristics from the conventional generation units, including load frequency control, voltage regulation and system level automatic generation control; The DG units connected to the distribution network could present a complicated pattern of load flow, which will affect the utilization levels and power losses, and they could also alter the fault level. The power electronic interfaces may introduce different transient and dynamic behaviours, therefore it is expected the distribution system with large number of renewable energy based DG units will present very different dynamic characteristics in comparison with the conventional systems. As the number of renewable energy based DG units increases, the aforementioned impacts would become more serious, and have the possibility of limiting the capacity of accepting the integration of the renewable energy based DG units. Therefore, it is critical to assess the impacts of the DG installation on power systems so that good quality and secured power supply can be provided. One of the most important issues is the protecting relay systems.

The penetration of DGs changes the traditional distribution power system short circuit power, fault current level and the characteristics of the fault current, such as amplitude, direction, distribution. So protection systems developed for radial systems are facing great challenge. Also the reclosing schemes of power systems will be affected. The

*Z. Chen is with Aalborg university, Denmark, (e-mail: zch@iet.aau.dk)

**W. Kong is with Tsinghua university, China and currently at Aalborg University as a visiting researcher.

coordination of relays needs to be reconsidered, and the coordination between the reclosing strategy and the anti-islanding action should be taken into account as well.

This paper is focused on the protection coordination. Coordination is a basic requirement for operation of protective relays, active research has taken place in this area. The influence of the distributed generation on the directional relays based on the symmetrical components of the currents was discussed in [1]; the distance relay algorithm was discussed in detail in [2]; and the coordination of overcurrent protection for ring-fed distribution network with distributed generators was investigated in [3]; the coordination between recloser and fuse was discussed and a method to choose recloser curves to achieve coordination was proposed in [4]. Single phase grounding faults were simulated, and the results indicate that the grounding faults caused by distributed generators could be dealt with by using rapid anti-islanding protection in [5].

The distribution power system automation techniques have been widely adopted and the infrastructure of communication has been developed. The protections based on microprocessors with communication capabilities are utilized, so that the status of the relays and breakers can be obtained from the distribution power system supervisory control and data acquisition system, which can serve as an information exchange platform. Based on the platform, the protection coordination and adaptation can be dealt with flexibly.

The protection system based on the Multi-agent technology has been proposed. An agent-based current differential relay using a communication network was investigated in [6]; an agent-based paradigm for self-healing protection systems was proposed in [7]; and a decentralized multi-agent based protection with capability of detecting high impedance fault and fault location, and shedding load for the DGs systems was discussed in [8].

A protection coordination based on multi-agent technology for distribution systems with DG units is discussed in this paper.

II EFFECTS OF DGs ON POWER SYSTEM FAULTS

Different types of DGs may present different fault characteristics. If power electronic converters are used as the interface for DGs, due to the fast switching and control

nature of power electronic converters, the short circuit currents and transients from the converter system may be distinctly restrained. Also, automatically reclosing device may fail: since the fault may not be cleared because the fault may be fed from DGs. In case that the islanding operation happens, the voltage and frequency may be varying due to power unbalance, so that a reclosing without synchronization could wrongly connect two systems which may not meet the synchronization condition, consequently, cause system dynamic problems. Extended delay time may have to be adopted between the separation of the DG units and the reconnection of the utility supply to make sure fault clearing possible. The total reclosing delay time may be prolonged to 1 second or so.

When DGs are connected into the distribution power grid, the grounding strategy should be taken into account. There are various grounding methods: solid grounding or impedance grounding (including small resistance grounding and reactor grounding), or no grounding. In [9], interconnection of distributed generators to power systems was discussed in detail. From the view of protection, a different grounding strategy will result in different fault current distribution, and then the sensitivity of the protection devices could be affected.

III PROTECTION ARRANGEMENT BASED ON MULTI-AGENT

Structure of protection agent

The radial topology is still mostly adopted in many distribution power systems. Because of DGs introduction, the system operation and fault response could be changed as discussed above. The traditional time overcurrent protection arrangement may not satisfy the new situation. But the protection arrangement may be improved by taking the advantage of the aforementioned information exchange platform, which can be based on the data platform of the distribution power system automation. The whole protection agent system may take the format as illustrated in Fig. 1. The whole protection management system may be classified into two layers: the substation layer and the protection (Intelligent Electronic Devices) IED layer.

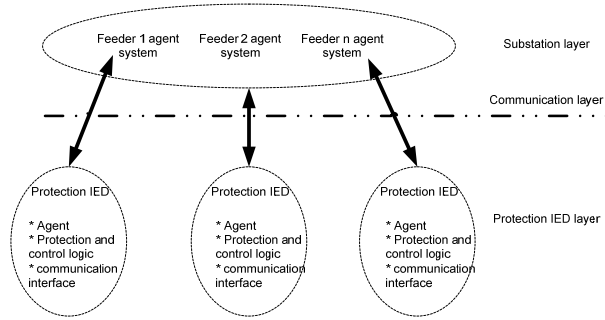

Fig. 1 Structure of protection agent

The substation layer is the kernel of the whole agent system. The functions of the substation layer are described as follows:

- 1) obtain the power system status by a SCADA system, and process the information from the control nodes, which are located on some distribution busbars and can be classified into three types: Normal nodes; Interconnection nodes; PCC nodes;
- 2) to establish protection strategies;
- 3) to create logic for inter-locking and inter-tripping;
- 4) to create strategy for protection backup;

The protection IED layer is the second subsystem, which form the detailed protection and control logics to deal with each individual fault.

Communication

The communication is the basis to realize the protection agent system. There are various communication structures, such as synchronous digital hierarchy network (SDH), microwave etc. But the field bus interfaces (for instance CAN bus [10]) is a popular and cheap communication method for microprocessor based relays. The Elec-Optic can be adopted to convert the electrical signal to optical signal, and then the digital signals are transmitted through optical fibres (wavelength 1.31um or 1.55um).

A CAN message data frame is composed of 7 different bit fields: start of frame, arbitration filed, control field, data field, CRC field, ACK field, end of frame. The maximal length of data field is 8 bytes. The standard data frame is up to 109 bits long. The bit rate is up to 1Mbit/sec.

If the transmission speed is 19200bit/s, the whole standard data frame can be transmitted in 5.7ms, and it takes no more than 5ms in the transmission channel. So the time should be less than 11ms. In general, the calculation time of

relay is no more than 30ms.

IV CASE STUDY

A simplified radial distribution power grid is shown in

Fig. 2.

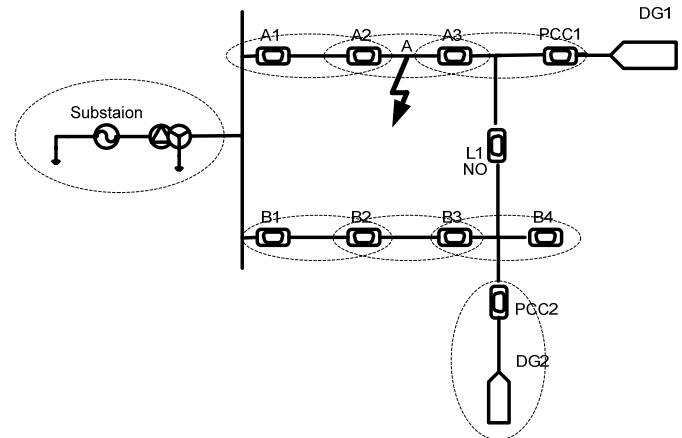

Fig. 2 A simplified grid structure

Case 1 reported in the paper is a single-phase grounding fault occurred at 0.5s of simulation time at point A with 10ohms grounding resistance. The DGs, having capacity of 150kW each, are based on power electronics interfaces and connected into the grid by Y/delta transformers. Each supplies 95% of its local load.

The setting of the over-current relay is 200% of the overload current. When the single phase fault happens at A, both relay A1 and A2 will start up by the overcurrent and the downstream power direction. Then the relay A1 and A2 send the message including direction and overcurrent indications. If the relay A1 and relay A2 both indicate the overcurrent and downstream direction, then relay A2 may call the downstream relay A3 for the information of current, voltage and direction indications at Relay A3. The logic of relay A2 is shown in

Fig.3.

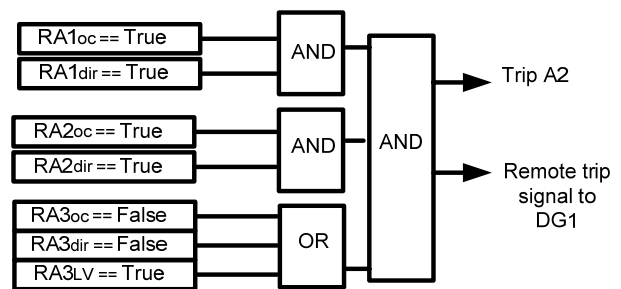

Fig. 3 The logic of relay A2 (prohibiting DG islanding operation)

(OC: overcurrent; LV: low voltage)

(dir: power direction, downstream = True, upstream = False)

For the case of prohibiting DG islanding operation, the possible operation steps are as follows:

1) The relay A2 is tripped out, and the DG1 is also tripped out by sending the remote trip signal. Therefore islanding operation is not permitted in this case,

2) The relay A2 recloses, if the reclosing succeeds, then relay A2 sends indication to reconnect the DG1.

3) Otherwise, it indicates that a permanent fault between A2 and A3, the relay A3 will be tripped out, and the fault is isolated, then the interconnection breaker L1 is closed, and the DG1 may be reconnected to restore power supply.

Some simulation results are shown in Fig. 4.

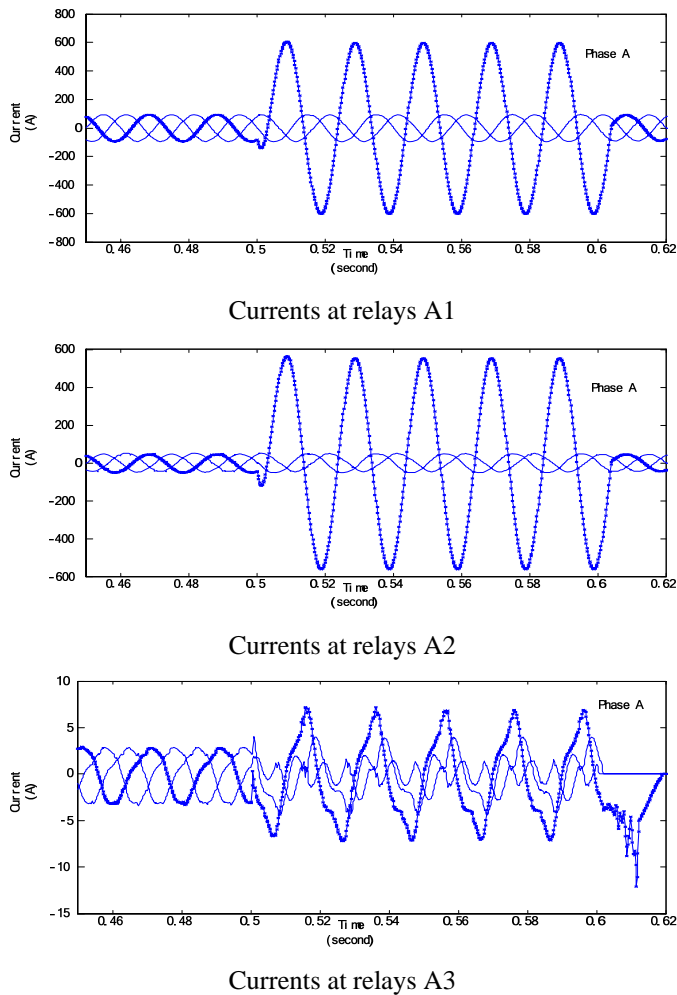

Fig. 4 Simulation results (prohibiting DG islanding operation), currents at relays A1, A2 and A3 downwards

Case 2 is a single phase grounding fault occurred at 0.5 s of

simulation time at point A with 10ohms grounding resistance.

The DGs, having capacity of 150kW each, are based on synchronized generators and connected into the grid by Y/delta transformers. Each supplies 95% of its local load. In this case, the permitting DG islanding operation and reclosing are taken into account.

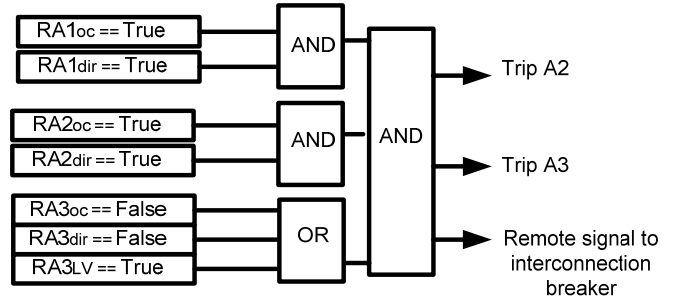

Fig. 5 The logic of relay A2 (permitting DG islanding operation)

The relay operation steps are as follows:

1) The relays A2 and A3 are tripped out, while the DG1 stay in network to supply some its local load in islanding operation mode.

2) The relay A2 recloses, if the reclosing succeeds, then relay A2 sends indication to reconnect the A3.

3) Otherwise, it indicates that a permanent fault between A2 and A3, the DG1 may keep the islanding operation mode until the fault is cleared or it may be connected the network through the interconnection breaker L1.

Some simulation results are shown in Fig. 6.

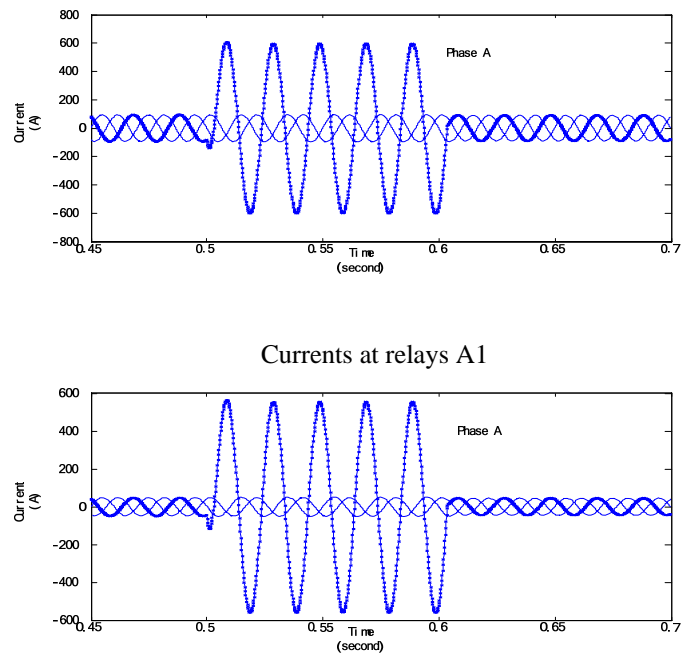

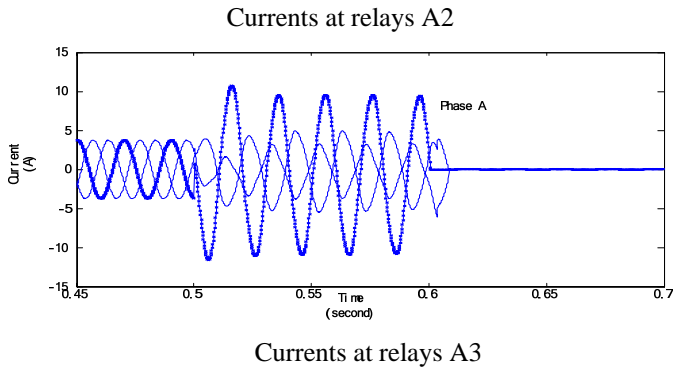

Fig. 6 Simulation results (permitting DG islanding operation), currents at relays A1, A2 and A3 downwards

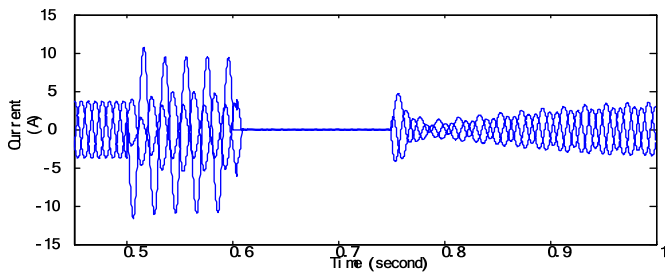

Fig. 7 Reclosing the interconnection breaker L1 without synchronization

In **fig. 6**, it is shown that the DGs based on synchronized generators have more notable impact on the faults than that based on electronic converter interface (in **fig. 4**) because of the characteristics of the electronic converter control strategy. And in **fig.7**, it is shown that the reclosing without synchronization device results in reclosing power swing. Therefore, in order to realise the islanding operation, more devices may be required, such as synchronization device may need to be installed at the selected possible busbars and the DGs should have the fast regulation ability to avoid the reclosing overshooting and the power swing of the DGs.

V CONCLUSION

When DGs are connected into the distribution power system, the coordination of the protection will become complicated. In this paper, a protection arrangement based on multi-agent is discussed. The proposed method takes the advantage of the information platform of distribution power automation systems. It has better performance than the traditional protection arrangement, such as protection coordination and fault location, but when the communication fails it may degrade to transitional time-overcurrent protection

scheme.

VI REFERENCES

- [1] Petit M, Le Pivert X, Bastard P, Gal I, "symmetrical components to suppress voltage sensors in directional relays for distribution networks: effect of distributed generation", *Developments in Power System Protection, 2004. Eighth IEE International Conference, Vol.2*, pp. 575 – 578, 5-8 April 2004
- [2] Chilvers, N, Jenkins and P. Crossley, "Distance relaying of 11kV circuits to increase the installed capacity of distributed generation", *Generation, Transmission and Distribution, IEE Proceedings*, pp. 40 – 46, Jan 2005
- [3] So, C.W., Li, K.K., "protection relay coordination on ring-fed distribution network with distributed generations", *TENCON '02. Proceedings, vol.3*, pp. 1885 – 1888, 28-31 Oct. 2002
- [4] Brahma. S.M., Girgis. A.A., "Microprocessor-Based Reclosing to Coordinate Fuse and Recloser in a System with High Penetration of Distributed Generation", *Power Engineering Society Winter Meeting, 2002. IEEE*, pp. 453 – 458, Jan. 2002
- [5] L.K.Kumpulainen, K.T.Kauhaniemi, "aspects of the effects of distributed generation in single-line-to-earth faults", *Future power system 2005*, pp. 1-5 Nov. 2005
- [6] Coury. D.V., Thorp. J.S., Hopkinson. K.M., Birman. K.P., "An agent-based current differential relay for use with a utility intranet", *IEEE Transactions on Power Delivety, Vol. 17*, pp.47-53, Jan.2002
- [7] Su Sheng, Li K.K., Chan. W.L., Zeng Xiangjun, Duan Xianzhong,, "Agent-Based Self-Healing Protection System", *IEEE Transactions on Power Delivety, Vol. 21*, pp. 610 - 618, April 2006
- [8] Zeng Xiangjun, Li K.K., Chan. W.L., Su Sheng, "Multi-Agents Based Protection for Distributed Generation Systems", *Electric Utility Deregulation, Restructuring and Power Technologies, 2004*, pp. 393 - 397, April 2004
- [9] Nagpal. M., Plumpre. F., Fulton. R., Martinich. T.G., "Dispersed generation interconnection-utility perspective" *IEEE Transactions on Industry Applications, Vol. 42* pp. 864 - 872, May-June 2006
- [10] CAN specification, version 2.0, Robert Bosch GmbH, Stuttgart, 1991