



Aalborg Universitet

AALBORG UNIVERSITY
DENMARK

Detection of Damage in a Lattice Mast Excited by Wind by Dynamic Measurements

Pedersen, Lars; Brincker, Rune

Published in:

Proceedings of the 2nd International Operational Modal Analysis Conference

Publication date:

2007

Document Version

Publisher's PDF, also known as Version of record

[Link to publication from Aalborg University](#)

Citation for published version (APA):

Pedersen, L., & Brincker, R. (2007). Detection of Damage in a Lattice Mast Excited by Wind by Dynamic Measurements. In R. Brincker, & N. Møller (Eds.), Proceedings of the 2nd International Operational Modal Analysis Conference (Vol. Vol. 2, pp. 659-667). Aalborg Universitet.

General rights

Copyright and moral rights for the publications made accessible in the public portal are retained by the authors and/or other copyright owners and it is a condition of accessing publications that users recognise and abide by the legal requirements associated with these rights.

- ? Users may download and print one copy of any publication from the public portal for the purpose of private study or research.
- ? You may not further distribute the material or use it for any profit-making activity or commercial gain
- ? You may freely distribute the URL identifying the publication in the public portal ?

Take down policy

If you believe that this document breaches copyright please contact us at vbn@aub.aau.dk providing details, and we will remove access to the work immediately and investigate your claim.

DETECTION OF DAMAGE IN A LATTICE MAST EXCITED BY WIND BY DYNAMIC MEASUREMENTS

Lars Pedersen, Department of Civil Engineering, Aalborg University, Denmark

Rune Brincker, Department of Civil Engineering, Aalborg University, Denmark

lpe@civil.aau.dk

Abstract

The paper illustrates the effectiveness of monitoring the dynamic response of a system for detection of damage herein using an output-only assessment scheme. The system is a 20 m height steel lattice mass excited by wind and the mast is instrumented with accelerometers picking up dynamic responses under ambient loading conditions. The paper presents the instrumentation and considerations regarding layout of instrumentation and strategies for acquisition and processing of data. Damage in the mast is provoked using a hacksaw and the cross sectional area of one the diagonals of the mast (one located close to the foundation) is gradually reduced by sawing deeper and deeper into the diagonal. During the process of introducing damage to the mast, its dynamic responses are recorded. By postprocessing these recordings, the changes in dynamic characteristics of the mast with the size of damage are identified. By studying the recorded variations it seems reasonable to conclude that by implementing a vibration monitoring system on the mast it would be possible to reliably detect a damage corresponding to less than a 50% loss of cross sectional area of the diagonal. This would allow for issue of a warning of a potential progress towards structural collapse prior to its occurrence.

1 Introduction

When the integrity of a dynamic system is to be assessed there are a number of options at hand ranging from visual inspection of the structure to the employment of advanced system identification methods relying on measurements of the dynamic response of the system to provide information useful for assessing the integrity of the system. This paper considers the efficiency of system identification methods and thus dynamic measurements for the evaluation of structural integrity, and in general there are a range of different techniques that may be useful to employ in this context, see e.g. refs. [1] - [8]. Some of these references represent research efforts made at Aalborg University in the field of system identification of civil engineering structures, and refs. [9] - [11] give overviews of the developments within the field that address changing traditions and renewed proposals for how to record and process data.

Diagnosing a structural system may encompass issues related to for instance i) detection of damage, ii) localization of damage, iii) quantification of the size of damage. Generally, the design and scale of a monitoring system depend on the purpose of the system, i.e. which level/type of information concerning system integrity that is to be conveyed to decision makers. This paper focuses on the procedures employed for designing a vibration monitoring system for a specific structure; a monitoring system targeted for detecting damage in the structural system (information level i) based on measurements of the global dynamic response of the system, specifically by monitoring changes of its dynamic characteristics. Moreover, the paper examines the capability of

the chosen monitoring system design by testing its usefulness in detecting damage. Prior to settling on an instrumentation and system identification strategy for that matter, efforts are made to understand the system and how it will react to damage. These preposterior analyses involves finite element modelling of the system and provide information about the dynamic characteristics of the undamaged system and an understanding of how these characteristics are expected to change if damage is introduced in the system. On basis of the preposterior analyses a suitable instrumentation and system identification strategy is identified.

The dynamic system considered is a lattice mast excited by wind. An output-only based system identification procedure is adopted and a time-domain system identification strategy is chosen in order to avoid some of the bias error problems that may be involved with identification in the frequency domain.

Section 2 describes the lattice mast and the investigations and considerations made prior to designing the vibration monitoring system. Section 3 describes the modal identification method employed, and Section 4 presents the recorded variation of dynamic characteristics with size of damage, and assessments are made related to the detectable size of damage.

2 The Mast and The Approach Adopted for Detecting Damage

In this section the mast and a monitoring system targeted for detection of damage in the mast is presented along with some of the considerations made in relation to designing an effective and efficient damage detection system.

2.1 The Lattice Mast

The mast subject to investigation and wind excitation is a steel mast of a height of 20 m erected on the premises of Aalborg University for the purpose of the investigations. Figure 1 shows pictures of the mast and the site at which it is located.



Figure 1. The mast viewed from different angles.

The four main vertical rafters of the mast are connected by diagonals and all connections are welded. For the main rafters, L 90x11 profiles are used, and for the lower diagonals of the mast, L

40x4 profiles are used. Figure 2 shows the overall geometry of the mast and indicates the diagonal in which damage deliberately is introduced (o) to test the capability of the monitoring system design. The damage is introduced about 2 m above the top of the concrete block that constitutes the top of the foundation of the mast. The concrete block reaches 1.8 m below ground level and at this level the concrete block is 3 by 3 m. The exterior contour of the upper section of the mast (upper 2 meters) is provided with plates of plywood as can be seen in figure 1, with the effect that a large proportion of the wind excitation is transferred to the mast here, as the plates are more effective in obstructing the wind flow than the lower cross sections of the mast.

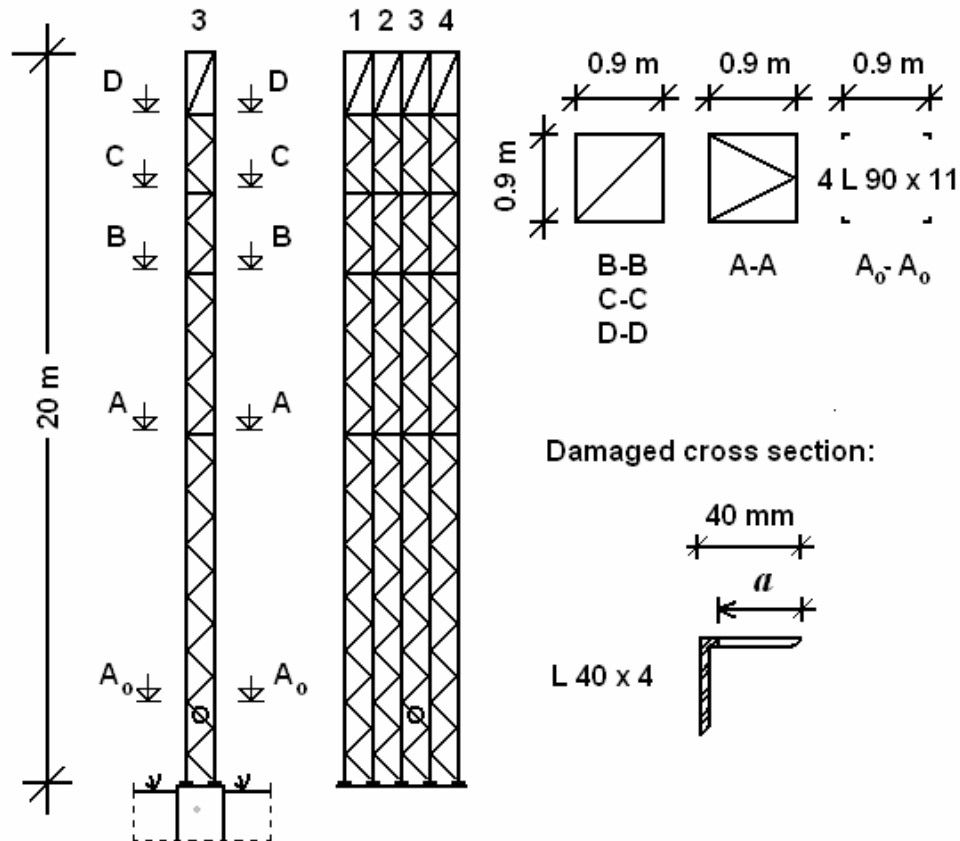

Figure 2. The mast and identification of the diagonal in which damage is introduced (o). Definition of the state of damage in the diagonal by the parameter a (the depth of the kerf).

The damage in the L 40x4 diagonal is introduced using a hacksaw increasing damage size in steps of 2.5 mm. Values of a of 0, 2.5 mm, 5 mm, 7.5 mm, 10 mm, ... , up to 40 mm are considered for the present studies.

2.2 Finite Element Model and Behaviour of Natural Frequencies

Prior to making decisions about the design of the monitoring system, a finite element model of the lattice mast was implemented. By this model, estimates of system natural frequencies were obtained. Furthermore, the model was used to study the sensitivity of natural frequencies of

different modes of vibration to damage in the diagonal later to encounter a cross sectional reduction using a hacksaw. The finite element model was constructed using Bernoulli Euler beam elements for main rafters and diagonals, and the foundation (the concrete block) was assumed not to experience any deformations. By gradually refining the element resolution of the finite element model, the three first natural frequencies of the undamaged mast were found at 2.02 Hz, 2.03 Hz, and 8.33 Hz, respectively. The frequencies at 2 Hz represent the two lower translational modes (slightly different in terms of frequency due to asymmetry in the structure) and the 8.33 Hz mode represents the 1. torsional mode of the mast which is a mode well separated from other modes of vibration, as the next set of translation modes appears at about 12 Hz.

Damage in the diagonal was modelled by reducing its cross sectional area in the numerical model (over the entire length of the diagonal). The damage was gradually increased thus emulating damage growth and at each damage state, the system natural frequencies were extracted from the model. From this separate study, it was identified that the frequency of the 1. torsional mode would be the frequency of the system most sensitive to the introduction of damage. It was chosen to target the design of the damage detection system for the identification of the natural frequency of this mode and to neglect any information about the structural integrity that might be hidden in for instance estimates of frequencies of other modes. Basically, the structural system will be considered a SDOF system, which due to the well-separated modes, can be achieved by suitable filtering of system output. On one hand this means that not all information brought about by measurements will be used for diagnosing the system, but on the other hand, this approach to modelling and identifying the system reduces model complexity; a complexity which else could become troublesome for at least some system identification methods.

The preposterior (FEM) analyses of the behaviour of the damaged system has thus provided information useful for deciding on the dynamic characteristics to be monitored for this specific structure and for the specific application of the monitoring system (detection of damage in a diagonal). The decisions made in terms of which modes to monitor have impact on choices next to be made about instrumentation, data acquisition strategy, filtering strategy and also on the choice of method to be used for estimating dynamic characteristics.

2.3 Instrumentation, Data Acquisition and Signal Conditioning

A set of two uni-axial Schaevitz-type accelerometers were mounted close to the top of the mast (some 2 meters below its top) according to the layout plan shown in figure 3.

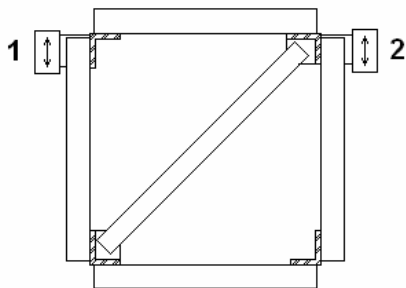

Figure 3. Positioning and measurement directions of accelerometers.

Noticeably, the instrumentation does not allow estimation of operational deflection shapes; estimates which could be useful when attempting to diagnose the system. Instead, a rather sparse instrumentation is chosen so as to investigate the capability of this instrumentation in terms of damage detection.

The accelerometers were sampled at a frequency of 32.6 Hz recording 4-min output sequences. 6 sequences were recorded for each damage state (one after another with a few minutes in between) so as to provide a basis for assessment that can be addressed from a statistical point-of-view.

The entire test programme including measurements at damage states of $a = 0$ mm to $a = 40$ mm was completed within about 12 hours. The measured acceleration signals were subject to filtering before and after storage on the hard-disc of a PC. An analogue 8-pole Butterworth low-pass filter with a cut-off frequency of 12.2 Hz was applied in order to eliminate aliasing errors, and the recorded signals were pre-amplified using a suitably selected amplifier in order to minimize quantification errors associated with amplitude discretization of the recorded analogue signals.

Subsequently, a digital band-pass filtering of recorded signals was performed using a Yulewalker filter. Prior to settling on a band-pass frequency range, a number of numerical simulations of system response was carried out followed by estimation of the a priori assumed/known dynamic characteristics, and it turned out that a band-pass range of 2.4 Hz would be useful. In the numerical investigations as well as in the analysis of measured acceleration signals, the central frequency of the filter was set at 8.33 Hz corresponding to the frequency of the 1. torsional mode identified from FEM-studies of the system. By using the band-pass filter only the 1. torsional mode remains for the identification of the system.

3 Modal Identification Procedure

The filtered time series of the responses of the mast to the excitation of wind were subsequently analysed with the purpose of estimating the natural frequency of the 1. torsional mode of the mast. This section describes the methods applied in this context and the procedures used to validate the approach and to validate assumptions related to its use.

The natural frequency associated with the 1. torsional mode was estimated from each 4-min record employing an ARMA(n, m) model defined by the equation:

$$x_t = \sum_{i=1}^n \Phi_i x_{t-i} - \sum_{i=1}^m \Theta_i e_{t-i} + e_t \quad (1)$$

where x_t represents the response signal, and e_t the time series of a white noise process. The AR-parameters (the first term of the equation) controls the Auto Regressive part of the response whereas the MA-parameters (the second term of the equation) controls the Moving Average part of the response. As can be recognized, the model assumes that the response can be represented by a linear combination of past output (response) and present and past input (excitation). It is advantageous that the ARMA model provides unbiased estimates of the dynamic characteristics of the system under certain assumptions. These involve the assumption of a stationary Gaussian white noise excitation of the system and the assumption of a linear system, and optimally these assumptions are to be checked as an integral part of validating the model.

Another attractive feature of the ARMA model is that the calibrated parameters of the model (specifically the AR-parameters) are directly linked to the dynamic characteristics of the system, f_i and ζ_i , through the roots of the system λ_i . The $2n$ roots of the system (λ_i) can be estimated from the characteristic polynomial:

$$\lambda^{2n} - \Phi_1 \lambda^{2n-1} - \dots - \Phi_{2n-1} \lambda - \Phi_{2n} = 0. \quad (2)$$

Prior to this, the AR-parameters are estimated by minimizing an error function related to the variance of e_t .

The roots (λ_i) are related to μ_i by the equation:

$$\lambda_i = \exp(\mu_i \Delta t) ; \quad i = 1, 2, \dots, 2n \quad (3)$$

where Δt represents the sampling interval of the recorded time series, and where

$$\mu_i = -2\pi f_i \zeta_i \pm i 2\pi f_i \sqrt{1 - \zeta_i^2} ; \quad \zeta_i < 1. \quad (4)$$

Eqns. (2)-(4) illustrate the direct link between the dynamic characteristics of the system (f_i, ζ_i) and the ARMA parameters calibrated to the discretely sampled response of the system (x_t).

In the present application an ARMA(2,1) model is assumed for calibrating the ARMA model and its parameters, as the filtering of the recorded response has ensured that only a single mode dominates the output (x_t) used as input for model calibration. This is in accordance with recommendations in ref. [5] and it significantly reduces computation time for the ARMA calibration due to the reduction of model complexity. As previously mentioned, by the filtering, some, potentially useful, information about the system is discarded and thus neglected in the subsequent system diagnosis. But neglecting that information is part of the purpose of the investigations. The sufficiency of the model order ($n = 2$) of the ARMA model applied on filtered output was validated using some of the techniques recommended in ref. [5].

Generally, other system identification methods could have been adopted such as automated PolyMAX (see for example ref. [12]) or automated FDD (see for example ref. [13]). These methods would be expected to perform somewhat better than an ARMA calibration in the event that the system to be identified was complex and required the output from multiple channels to be handled. Moreover, fully automated identification (without a need for user action after setting up the system) would be useful if the system was actually to be implemented on the structure for long-term monitoring. For the short-term exercise at hand and considering the simplicity of the system, the ARMA calibration described above is considered a suitable method for identifying the system characteristics.

3.1 Validation of Basic Assumptions

For the estimation of system natural frequencies using the approach outlined above it is assumed that the excitation represents a stationary Gaussian white noise process and that the system is linear. The validity of these assumptions is considered and discussed in this section.

It is common to assume that the turbulence component of wind is well represented by a random Gaussian process, and hence this is not investigated any further in this paper. As for whiteness of the excitation, a way to perform an evaluation without access to actual wind registrations from the site, is to turn to wind spectra available in codes and standards. Doing so, it appears that the whiteness of resonant excitation (i.e. whiteness in a frequency region around a natural frequency) increases with increases in natural frequency. It is assessed that for a frequency corresponding to the 1. torsional mode of the mast (8.33 Hz), the whiteness assumption is quite reasonable at least considering the other uncertainties involved with the frequency estimation.

A thorough investigation of system linearity was not performed, but for an evaluation of linearity, advantage was made of the fact that if a linear system is exposed to a Gaussian excitation, the response of the system will also be Gaussian. Hence, if the response is Gaussian, there is at least some indication of a linear system and a Gaussian excitation. The recorded responses of the mast were therefore postprocessed and a fair agreement between the probability distribution function of the response and that of a Gaussian distribution was noticed. Compliance with the stationarity assumption was also evaluated by analysing a few of the recordings, and these generally did not suggest the conditions to be significantly non-stationary.

Generally the outcome of validation tests reassured that main assumptions associated with the system identification strategy were not seriously violated, but naturally nature does not by nature ensure perfect compliance with assumptions and other factors than damage may influence system natural frequencies. Some degree of bias errors in frequency estimates is hence to be expected which need to be acknowledged when attempting to diagnose the system.

4 Results

The recorded variation of the first torsional frequency of the mast with size of damage (a) is shown in figure 4. At each damage state, six time series were recorded per accelerometer (i.e. 12 time series and 12 frequency estimates), which allowed for extraction of the mean value of the frequency estimate and for evaluating the uncertainty associated with the estimate. It is chosen to illustrate the uncertainty by displaying the 95% confidence levels associated with the estimates at the states of damage considered. The 95% confidence levels are obtained by assuming a Gaussian distribution of the natural frequency estimate.

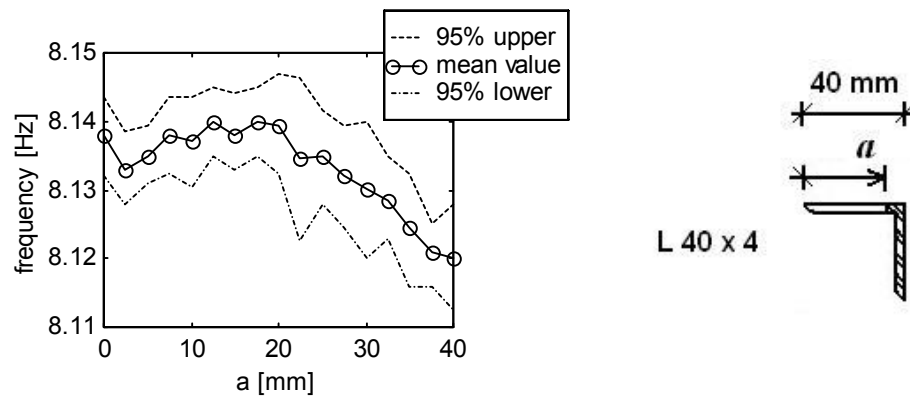

Figure 4. The measured decline of natural frequency with size of damage (solid line) and 95% confidence levels of frequency estimates (dashed and dotted lines).

First item to notice is that measurements suggest a frequency of about 8.14 Hz for the undamaged mast ($a = 0$ mm) for which the finite element model suggested a frequency of 8.33 Hz, thus overall indicating a reasonably accurate finite element model. The variation of frequency with size of damage (a) is of primary interest and as can be seen in figure 4, and as expected, the natural frequency declines as a increases (solid line). At least this tendency becomes obvious for damage sizes beyond 25 mm. The dashed and dotted lines that indicate 95 % confidence levels associated with the frequency estimate are useful in the context of assessing confidence associated with the detection of damage. At a damage of about 35 mm, the upper 95% confidence level associated with the frequency estimate descends below the lower 95% confidence level associated with the undamaged state. If employing this, probably robust, criterion for the detection of damage, it would be possible to detect damage of a size corresponding to less than a 50% cross sectional reduction of the diagonal. Separate studies have shown that at this damage state, the structural safety is still acceptable, and if the damage was a fatigue crack developing in the diagonal, and if the crack was

detected at this damage state, the mast could be rehabilitated prior to encountering an unacceptable safety level.

It should be noted that a potential dependency of dynamic characteristics on environmental parameters (e.g. wind speed levels, wind direction, temperature) have not been examined and considered for the assessment of detectability of damage. The confidence of damage detection might be enhanced by initially mapping these relationships, as hereby their potentially disturbing effect can be removed from the damage assessment. At the same time it would ensure that a change in dynamic characteristics that is actually a result of changes in environmental parameters is not by mistake interpreted as a loss of structural integrity or increase herein. For the short-term (12 h) monitoring programme employed for testing the capability of the monitoring system, the variations of environmental parameters (specifically ambient temperatures and to some extent the wind climate) are limited compared with the variations that may be encountered during in-service long-term monitoring. For long-term monitoring it may prove useful to consider the environmental parameters when diagnosing the system.

5 Conclusion

The paper examined the usefulness of dynamic measurements for detection of damage in a dynamic system; a wind excited lattice mast experiencing damage in a heavily loaded diagonal. From a finite element representation of the system, the behaviour of the system at different damage states was examined prior to settling on a measurement and data acquisition scheme. The numerical investigations indicated that for the purpose of detecting damage in a diagonal at an early state, it would be useful to target the instrumentation and the system identification scheme for monitoring the decline of the natural frequency associated with the 1. torsional mode of the system.

The approach proved useful as by using only 2 accelerometers and rather simple system identification procedures to monitor the decline of this frequency while damage was introduced in the diagonal, it was possible to detect damage corresponding to less than a 50% reduction of the cross sectional area of the diagonal. The investigations serve as an example of the usefulness of including preposterior analyses of the dynamic behaviour of a system into the design of a monitoring/surveillance system. At the same time it demonstrates that output-only system identification techniques can be very efficient; in the present case in the context of detecting damage in a lattice mast.

6 References

- [1] Pandit, S.M, and Wu, S-M. "Time Series and System Analysis with Applications", John Wiley & Sons, Ltd., 1983.
- [2] Ljung, L. "System Identification: Theory for the User", Prentice Hall, 1987.
- [3] Kirkegaard, P.H. "Optimal Design of Experiments for Parametric Identification of Civil Engineering Structures", Ph.D. thesis, Aalborg University, Denmark, 1991.
- [4] Andersen, P. "Identification of Civil Engineering Structures using Vector ARMAR Model", Ph.D. thesis, Aalborg University, Denmark, 1997.

- [5] Jensen, J.L., "System Identification of Offshore Platforms", Ph.D. thesis, Aalborg University, Denmark, 1990.
- [6] Rytter, A., "Vibration Based Inspection of Civil Engineering Structures", Ph.D. thesis, Aalborg University, Denmark, 1993.
- [7] Asmussen, J., "Modal Analysis based on the Random Decrement Technique", Ph.D. thesis, Aalborg University, Denmark, 1997.
- [8] Pedersen, L., Hummelshøj, L.G., Møller, P., "Damage detection by response measurements" (in Danish), M.Sc. thesis, Aalborg University, Denmark, 1991.
- [9] Peeters, B., "System Identification and Damage Detection in Civil Engineering", Ph.D. thesis, Dept. of Civil Engineering, K.U. Leuven, Belgium, 2000.
- [10] Brownjohn, J.M.W., "Long-Term Monitoring of Dynamic Response of a Tall Building for Performance Evaluation and Loading Characterisation", Proc. of the 1st IOMAC, Copenhagen, Denmark, pp. 143-151, 2005.
- [11] Zhang, L., Brincker, R., Andersen, P., "An overview of Operational Modal Analysis: Major Developments and Issues", Proc. of the 1st IOMAC, Copenhagen, Denmark, pp. 179-190, 2005.
- [12] Peeters, B., Vanhullebeke, Van der Auweraer, H., "Operational PolyMAX for estimating the dynamic properties of a stadium structure during a football game", Proc. of the IMACXXIII, Orlando, Florida, US, 2005.
- [13] Brincker, R., Andersen, P., Jacobsen, N.A., "Automated Frequency Domain Decomposition for Operational Modal Analysis", Proc. of IMACXXV, Orlando, Florida, US, 2007