

# How can industrial heat decarbonisation be accelerated through energy efficiency?

Maghrabi, Abdullah M.; Song, Jian; Markides, Christos N.

DOI:

[10.1016/j.applthermaleng.2023.121092](https://doi.org/10.1016/j.applthermaleng.2023.121092)

License:

Creative Commons: Attribution (CC BY)

*Document Version*

Publisher's PDF, also known as Version of record

*Citation for published version (Harvard):*

Maghrabi, AM, Song, J & Markides, CN 2023, 'How can industrial heat decarbonisation be accelerated through energy efficiency?', *Applied Thermal Engineering*, vol. 233, 121092.  
<https://doi.org/10.1016/j.applthermaleng.2023.121092>

[Link to publication on Research at Birmingham portal](#)

## General rights

Unless a licence is specified above, all rights (including copyright and moral rights) in this document are retained by the authors and/or the copyright holders. The express permission of the copyright holder must be obtained for any use of this material other than for purposes permitted by law.

- Users may freely distribute the URL that is used to identify this publication.
- Users may download and/or print one copy of the publication from the University of Birmingham research portal for the purpose of private study or non-commercial research.
- User may use extracts from the document in line with the concept of 'fair dealing' under the Copyright, Designs and Patents Act 1988 (?)
- Users may not further distribute the material nor use it for the purposes of commercial gain.

Where a licence is displayed above, please note the terms and conditions of the licence govern your use of this document.

When citing, please reference the published version.

## Take down policy

While the University of Birmingham exercises care and attention in making items available there are rare occasions when an item has been uploaded in error or has been deemed to be commercially or otherwise sensitive.

If you believe that this is the case for this document, please contact [UBIRA@lists.bham.ac.uk](mailto:UBIRA@lists.bham.ac.uk) providing details and we will remove access to the work immediately and investigate.



## Vision Article

# How can industrial heat decarbonisation be accelerated through energy efficiency?

Abdullah M. Maghrabi<sup>a</sup>, Jian Song<sup>a,b</sup>, Christos N. Markides<sup>a,\*</sup>

<sup>a</sup> Clean Energy Processes (CEP) Laboratory, Department of Chemical Engineering, Imperial College London, London SW7 2AZ, United Kingdom

<sup>b</sup> Birmingham Centre for Energy Storage & School of Chemical Engineering, University of Birmingham, Birmingham B15 2TT, United Kingdom



## ARTICLE INFO

## Keywords:

Benchmarking  
Energy management  
Industrial energy efficiency  
Pinch analysis  
Waste heat recovery

## ABSTRACT

The ongoing energy transition necessitates commitments from various sectors to utilise resources more efficiently. Amongst these, the industrial sector, which is associated with high energy and resource consumption and emissions, has been attracting attention specifically aimed at performance enhancements and continuous progress in energy utilisation. The continued evolution of industrial operations and performance requires energy efficiency measures to be developed and implemented. Diverse portfolios of products, wide-ranging types of equipment, processes and, subsequently, plants, are adopted in the industrial sector, such that energy efficiency measures vary widely, along with their effectiveness, technological maturity, technical and economic impact. It remains a challenge to select the optimal energy efficiency measure(s) for a specific industry, plant and process, given the specific asset requirements. In this context, the development of systematic approaches for identifying optimal energy efficiency measures is of great interest. In this vision paper, we present an assembly of available systematic tools for advancing the energy efficiency of plants and sites in the industrial sector. The contribution of this work to the field of industrial heat decarbonisation arises from developing and proposing the use of a new holistic framework as a guide for the continuous performance improvement of thermal-energy-intensive industries through a series of energy efficiency measures and actions. Specifically, the framework suggests initiating efforts from a proposed top-down peer benchmarking practice aimed at identifying gaps in energy-efficiency performance across products, plants, processes and equipment. In a second stage, recommendations are made in form of a list of steps to close these gaps, starting with conducting equipment gap closure analyses, followed by design improvement studies at the process, plant and site levels using tools such as pinch analysis, steam system optimisation and residual waste heat recovery. We finally propose that simultaneous attention should be given to operational energy management programs along with a sequence of recommended actions to minimise deviations from the targeted energy-efficiency performance. In this vision paper, key technical tools needed to achieve the goal of continuous heat decarbonisation through energy efficiency are reviewed, and the organisational and management aspects required for effective energy targeting and management, and stakeholder engagement are addressed, based upon which relevant research challenges and opportunities are identified.

## 1. Introduction

The industrial sector is a dominant end-user of energy, and if energy-intensive industries are to survive and thrive through the sustainability and energy transition, they will need to continue producing socially beneficial products that provide energy, mobility and valuable materials whilst minimising and eventually eliminating adverse associated health and environmental impacts. All of this should be set against the backdrop of achieving profitability growth and efficiently deploying

investments to achieve these goals. At the same time, energy prices continue to exhibit volatile behaviour. Fig. 1 shows the historical evolution of the prices of natural gas and oil over the past couple of decades. The minimisation of energy consumption represents a compelling opportunity for industry to hedge against such price volatility, and to become more resilient economically. Furthermore, transitioning towards more effective operations in energy-intensive industries requires considerable capital to be invested into displacing current technological assets and replacing them with better performing ones. What adds to this challenge is that industrial facilities are often built as long-term

\* Corresponding author.

E-mail address: [c.markides@imperial.ac.uk](mailto:c.markides@imperial.ac.uk) (C.N. Markides).

<https://doi.org/10.1016/j.applthermaleng.2023.121092>

Received 17 March 2023; Received in revised form 29 June 2023; Accepted 29 June 2023

Available online 30 June 2023

1359-4311/© 2023 The Authors. Published by Elsevier Ltd. This is an open access article under the CC BY license (<http://creativecommons.org/licenses/by/4.0/>).

Nomenclature		WH	waste heat
<i>Abbreviations</i>		WHR	waste heat recovery
CAPEX	capital expenditure	<i>Symbols</i>	
CC	composite curve	$Q$	heat flow rate [W]
GCC	grand composite curve	$T$	temperature [ $^{\circ}$ C, K]
HEN	heat exchangers network	$\Delta$	difference
IEA	international energy agency	<i>Subscripts/superscripts</i>	
LCA	lifecycle analysis	C	cold utility
MILP	mixed-integer linear programming	H	hot utility
MINLP	mixed-integer non-linear programming	min	minimum
OPEX	operational expenditure	max	maximum
R&D	research and development	rec	energy recovery
RWH	residual waste heat		
TSP	total site profile		

investments that typically operate for two to three decades. Therefore, a high sense of urgency is needed to drive the incorporation of best practices and technologies to ensure not only short-term, but also longer-term future competitiveness.

Simultaneously, as shown in Fig. 2, the global energy mix is expected to remain dominated by fossil fuels in the short-to-medium term, despite growth in alternative energy sources such as renewable energy, while industrial energy consumption is expected to continue growing over the next couple of decades. Fig. 2 suggests that industry could be responsible for nearly two-fifths of the global energy consumption by 2040. The

challenge of rising industrial energy demands becomes directly associated with environmental concerns that are caused by the consumption of fossil fuels.

Given the above considerations, it is now widely held that changing how energy is generated and consumed in industries is a critical enabler for industrial decarbonisation. According to the International Energy Agency (IEA), the process industries, which are the industries involved in the extraction, transportation, and processing of raw materials with the goal of producing intermediate or final products using physical, mechanical, and/or chemical processes, are the largest energy consumer

### Brent | Natural gas

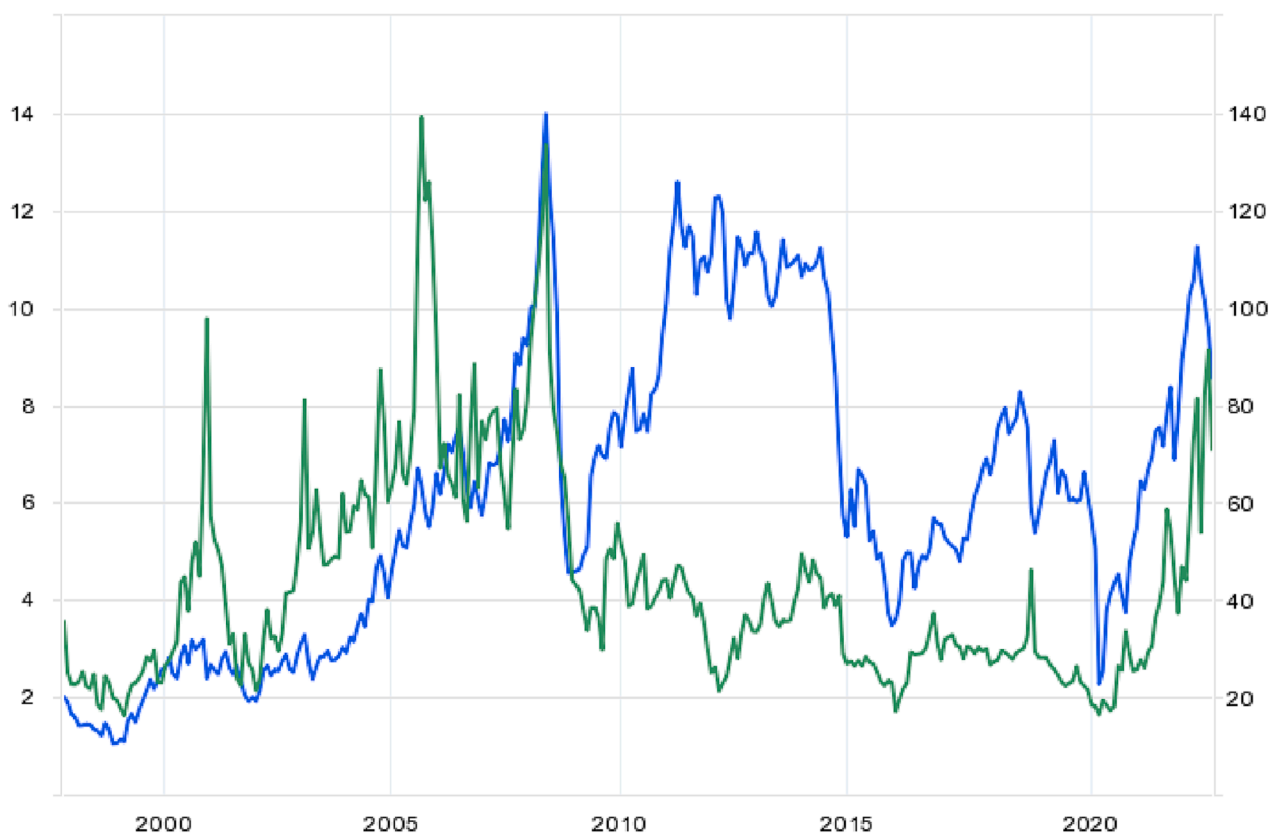

source: tradingeconomics.com

Fig. 1. Prices of oil (blue) in \$/barrel and of natural gas (green) in \$/MMBTU over the past two decades; reproduced from Ref. [1]. (For interpretation of the references to colour in this figure legend, the reader is referred to the web version of this article.)

### Primary energy consumption by fuel

Billion toe

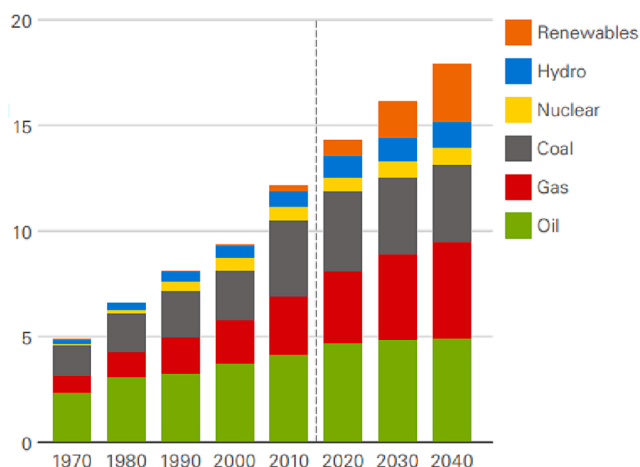

### Primary energy consumption by end-use sector

Billion toe

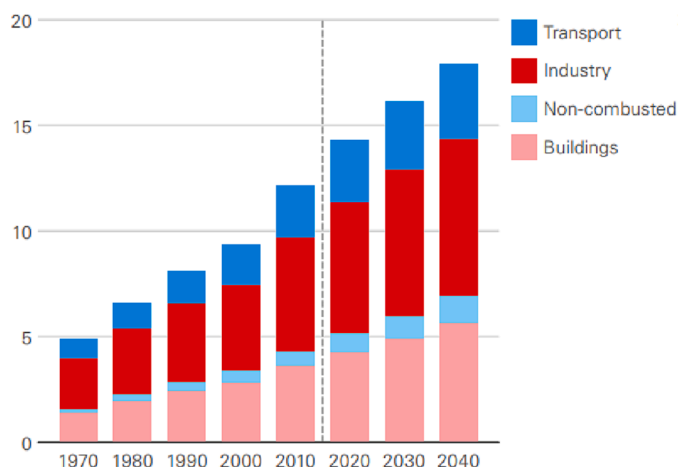

### CO<sub>2</sub> emissions by sector

Gt of CO<sub>2</sub>

Fig. 2. Historical trends and 2040 forecast of: global energy mix by fuel (top left), end-user energy consumption (top right), and CO<sub>2</sub> equivalent emissions by sector; taken from Ref. [2].

within the industrial sector. Subsequently, they are found to be the largest emitter of emissions, including gaseous emissions and other harmful pollutants, which are, in fact, forecasted to continue to increase in the near future [3]. At the same time, the industrial sector has been exhibiting remarkable improvements in reducing its energy intensity [4–7]. It has been reported by the European chemical industry council that the process industries in Europe had reduced their energy intensity by 47% from 1991 to 2019 [4,5]. Despite these notable improvements, however, due to an anticipated growth in demand [2], absolute energy consumption is projected to grow and continue to be dominated by fossil fuels.

When considering the production of bulk chemicals, such as olefins, for example, about 70% of the operating expenses (OPEX) of manufacturing plants are related to onsite energy consumption [8,9]. Therefore, when assessing measures for improving resource efficiency in process industries, it is generally found that energy conservation measures are particularly effective, not just in terms of efficiency improvements and emission reductions, but also better operating economics. Abatement cost ranges associated with the implementation of a variety of suggested measures and solutions are shown in Fig. 3. The IEA estimates that in the efforts to achieve the two degrees scenario targeted by the Paris agreement, 40% of the contribution needs to come from energy

efficiency measures [3], which is highlighted in curves such as this one as low-hanging fruit.

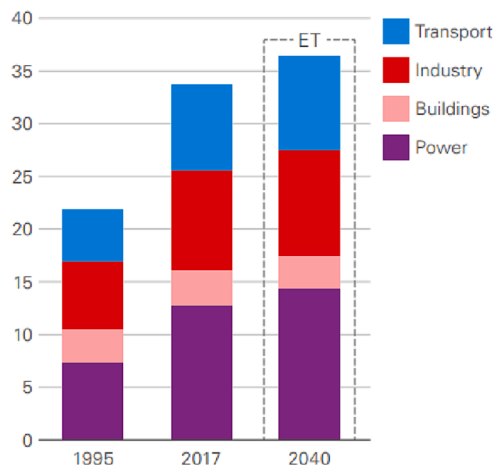
As mentioned above, the largest fraction of industrial primary energy use, and consequently, primary source of emissions, is associated with fossil-fuel consumption. This consumption mainly occurs due to the direct combustion of fossil fuels in the forms of both direct use, as feedstock processing, and indirect use for the production and provision of necessary utilities (e.g., heating, cooling or power). The consumption may take place directly onsite or indirectly by importing energy, of which the former represents 70–80% of the total energy consumption, while the latter accounts for the rest [11,12]. Moreover, about 80–90% of the total industrial fossil fuel consumption is used for heating purposes, either for process heating or steam production in boilers, making this a focal point for energy efficiency, emissions and decarbonisation efforts [11,12].

Close inspection of the aforementioned energy-intensive operations reveals that many of these take place at around double their theoretical minimum energy intensities [13]. Nonetheless, real-life operational issues influence the deviations from theoretical thermodynamic performance analyses. Moreover, variable seasonal conditions, unplanned shutdowns, market conditions and supply chain issues, amongst others, also lead to higher energy consumption than the design bases.

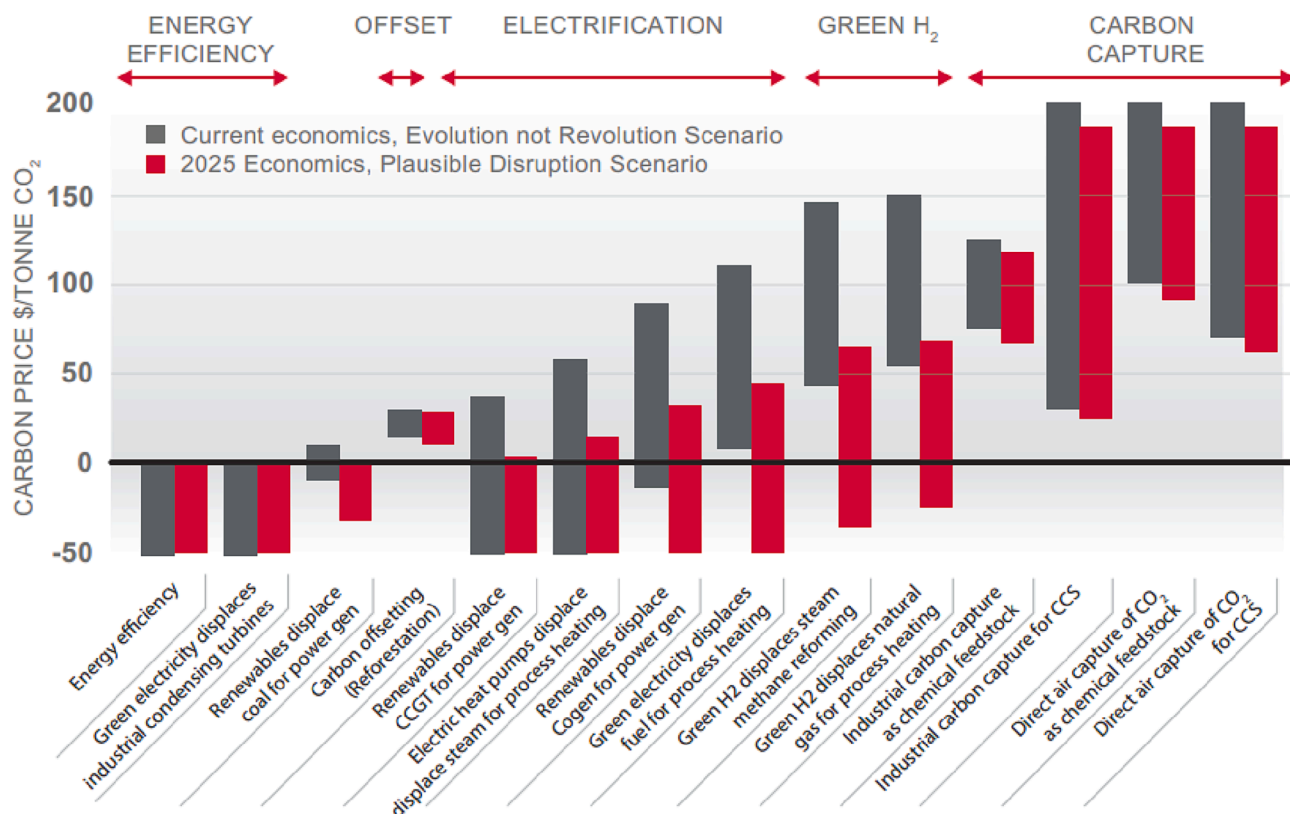

Fig. 3. Marginal abatement cost curve for different emission abatement measures; taken from Ref. [10].

In this paper, a referral to industrial sites, processes, plants, equipment or products adheres to the classification illustrated in Fig. 4. Industrial plants are designed for manufacturing products by converting raw materials, which take place in a number of gradual steps known as process, in which physical or chemical changes occur. These processes typically employ different types of equipment and require utility input (s), including heating, cooling and/or power. A plant flowsheet is established when these steps are combined and integrated with their utility provisions, also shown in Fig. 4. Depending on the size and complexity of the industry, a site can encompass multiple plants that produce several products, some of which could be intermediate ones used as feedstock for another plant.

When studying the decarbonisation of the energy used in the process industries, it is essential to appreciate that many activities will be within the scope of debottlenecking and revamping in an existing assets context rather than designing grassroots systems. Specifically, this can be expected for meeting short-to-medium-term efficiency and emissions targets. Longer-term targets, however, require more drastic changes to the process technologies, including going beyond reinvesting in modifications to the ones adopted and used today to displacing or replacing them with new options. Consequently, when considering how to maximise the energy efficiency of industrial systems, both in grassroots plants and operational ones, an integrated and cross-cutting framework needs to be followed.

The contribution of this work to the field arises from developing and proposing the use of a new holistic framework for the continuous decarbonisation of energy-intensive industries through energy efficiency measures, which is shown in Fig. 5. The proposed framework goes beyond previously published work in the literature by recommending a series of progressive energy-efficiency measures, starting with an assessment of a facility's energy performance through the establishment of baselines and peer benchmarking, which are discussed in Section 2. After determining the gaps between current and targeted performance, proposed gap-closure activities are discussed, starting

with design improvement studies addressed in Section 3. Furthermore, since design improvement studies usually leave behind gaps to be closed, the opportunities for residual heat recovery are reviewed in Section 4. Finally, operational deviations have a significant influence on energy efficiency performance even if energy recovery is inherently maximised in a facility's design; consequently, the prevalence of operational energy management practices is attended to in Section 5. To the best of the authors' knowledge, this study is the first to present a comprehensive and unified framework that can serve the energy-intensive industries as a guide for accelerating decarbonisation efforts through energy efficiency.

## 2. Benchmarking

In order to improve industrial operations, it is essential to know the performance of best-in-class solutions to propose to policymakers, designers, operators and owners of industrial facilities. Energy efficiency peer-benchmarking is a valuable tool that facilitates an understanding of the energy efficiency and emissions performance of equipment, process design, plant operations and maintenance management, or products compared to equivalent ones. As a result, we propose for policymakers, along with the other stakeholders, to use benchmarking to set realistic energy efficiency and emissions targets in a multi-level manner as illustrated in Fig. 6, where we propose to extend it from product families down to plants and processing facilities and all the way down to the equipment level.

A key advantage of benchmarking tools is that they can trigger a continuous improvement environment if they are programmed to be updated periodically. With time, and as solutions (e.g., new facilities are designed and deployed, or measures are implemented), the energy efficiency performance evolves, creating a continuous demand for energy efficiency improvement that initiates efforts from the stakeholders of the industrial sector. Stakeholders such as academia, research and development organisations, and engineering companies could be asked to

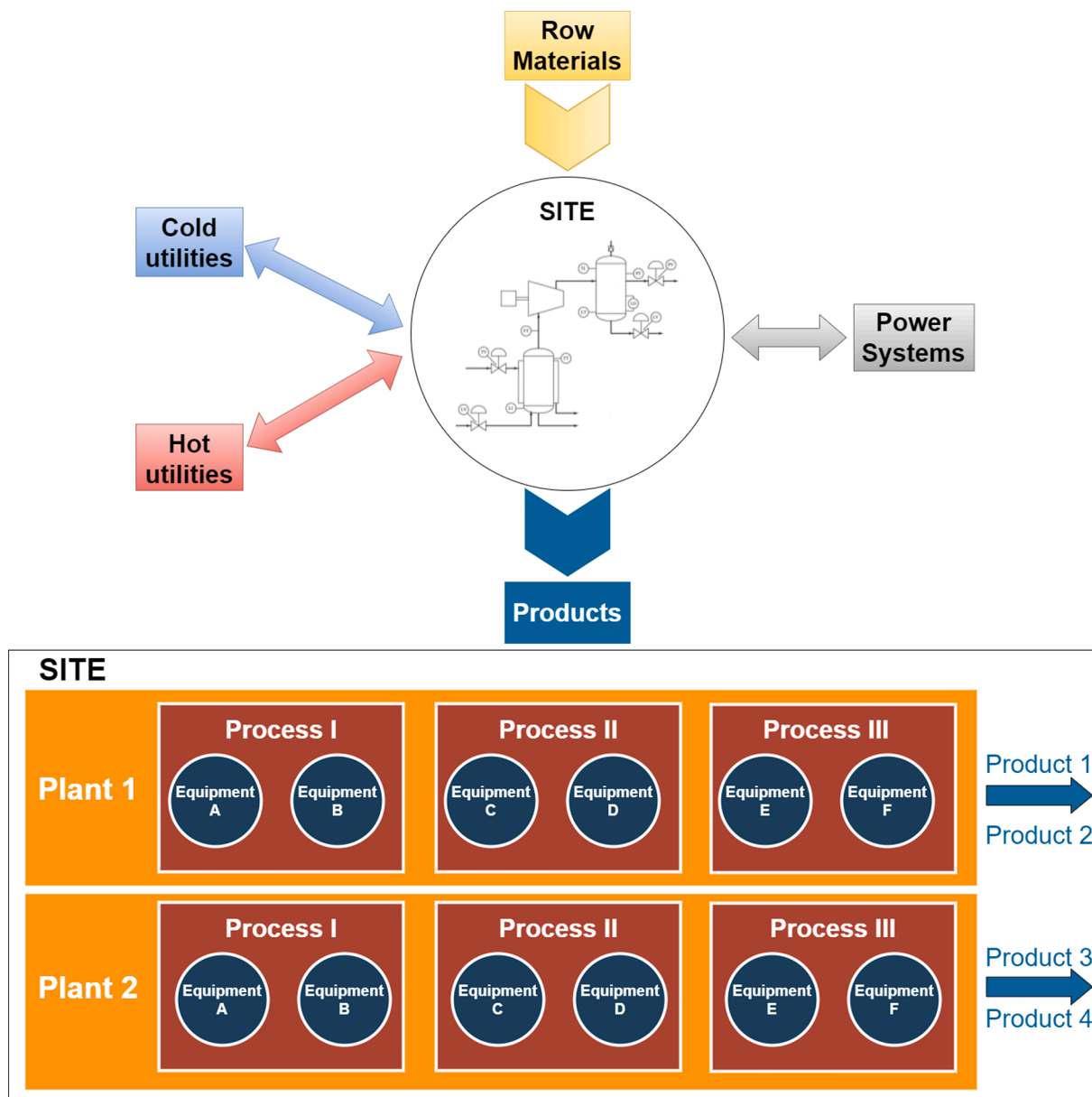

Fig. 4. Classification of a typical industrial process facility and its interactions with utilities.

bring forward next-generation technologies. Both industry and policy-makers can benefit from benchmarking in setting targets and driving the agenda for energy efficiency and resources consumption reductions.

Energy efficiency performance is usually quantified on an intensity basis, i.e., measured as the relative ratio between the absolute amount of energy consumed and the quantity of products produced, with J/t (t: tonne) as a common (but non-SI) unit:

$$\text{energy intensity} = \frac{\text{energy consumed}}{\text{production quantity}}$$

The equation above reflects the two ways in which the energy intensity can be improved: the first is to reduce the absolute amount of energy consumed, and the second is to maximise the production capacity, which is known in the industry as the maximisation of capacity utilisation. In Europe, the average capacity utilisation in the last couple of decades stands at around 85% [5]. Improving capacity utilisation is a crucial imperative for the bottom line of industrial operations. Still, it is also vital in enhancing the asset energy performance as it simultaneously reduces the intensity and improves the operational energy efficiency of

individual units, which often operate with higher efficiency performance at higher rates.

The following steps are suggested for effective energy efficiency benchmarks:

1. Selection of the benchmark portfolio family of either process equipment, process plants, or final products comparably. Comparability determination can be one of the most challenging activities in industrial benchmarking. For example, products such as olefins or polymers can be produced through different process technologies with fundamental differences in operations units, resulting in less meaningful comparison. Consequently, placing criteria such as similarity in the grades and specifications of the products and the raw materials used helps to ensure comparable technologies are benchmarked. Moreover, drawing geographical boundaries could help to obtain a more comparable benchmark. Having regions with different historical energy policies and energy prices often leads to variable regional performance due to the variance in local ecosystems and policies. However, the more global the benchmark portfolio is, the



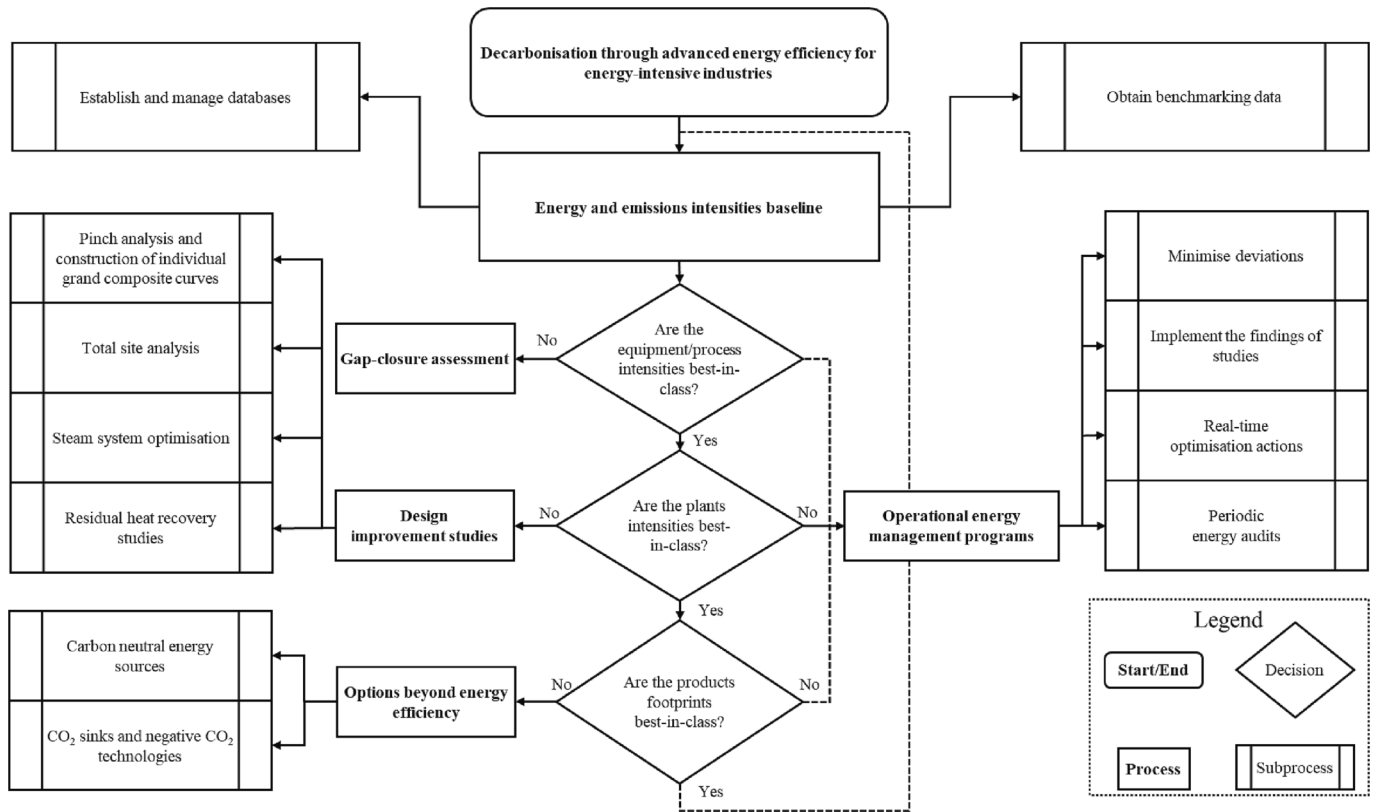

Fig. 5. Proposed steps for decarbonisation via advanced energy efficiency measures in energy-intensive industries.

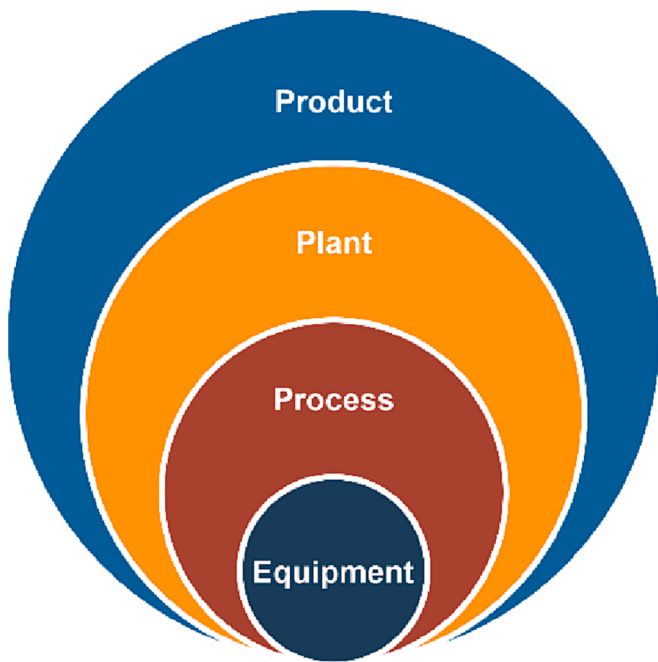

Fig. 6. Proposed benchmarking levels to drive industrial facilities' efficiency improvements.

better understanding of the actual best-in-class performance can be gained regardless of local issues.

- Collection of historical data to set a proper baseline for the benchmark portfolio [14,15]. As sensitive data related to technologies and economics are involved in the benchmarking processes, historically, there have been raising concerns regarding data exposure and

competition laws violations. Consequently, the more extensive a portfolio of participants in such benchmarking databases, the more achievable it becomes to eliminate confidential data traceability and exposure. This scenario can be challenging for some processes or products where few plants exist or participate. Thus, operators and owners of such industrial facilities need to be encouraged to join in benchmarking efforts. Also, both industry and policymakers need to collaborate on establishing and managing databases with guarantees for anonymity, which could only be achieved with as many participants as possible in such databases. Cervo et al. [16] proposed a concept to overcome such challenges and conducted a case study on a refinery to demonstrate how such solutions can be implemented in practice.

- Identification of asset performance improvements guided by a normal distribution. Implementing a statistical methodology that considers factors such as the number of facilities (i.e., frequency) in the benchmark and their specific production quantities provides a more meaningful depiction of their energy-intensity performance distribution. A normal distribution, such as in Fig. 7, can be used for this purpose, as it can assist with the identification of reasonable improvement targets.
- Establishment of time-bounded targets for operational assets to reach a certain performance quartile. After obtaining a picture of where each plant stands, setting an energy target based on the gap between the current and the targeted performance supports initiating the energy efficiency endeavours for these plants. Also, it is necessary to appreciate that timing is a crucial element in such frameworks because different industries have different time scales for implementing capital projects. For instance, if an energy improvement capital project will be implemented in a bulk chemicals facility, a timeframe of 3 to 5 years needs to be anticipated before realising any benefits in energy performance. The performance improvement to meet the targets needs to take that into account, and therefore, continuous dialogue between the stakeholders boosts the chances of

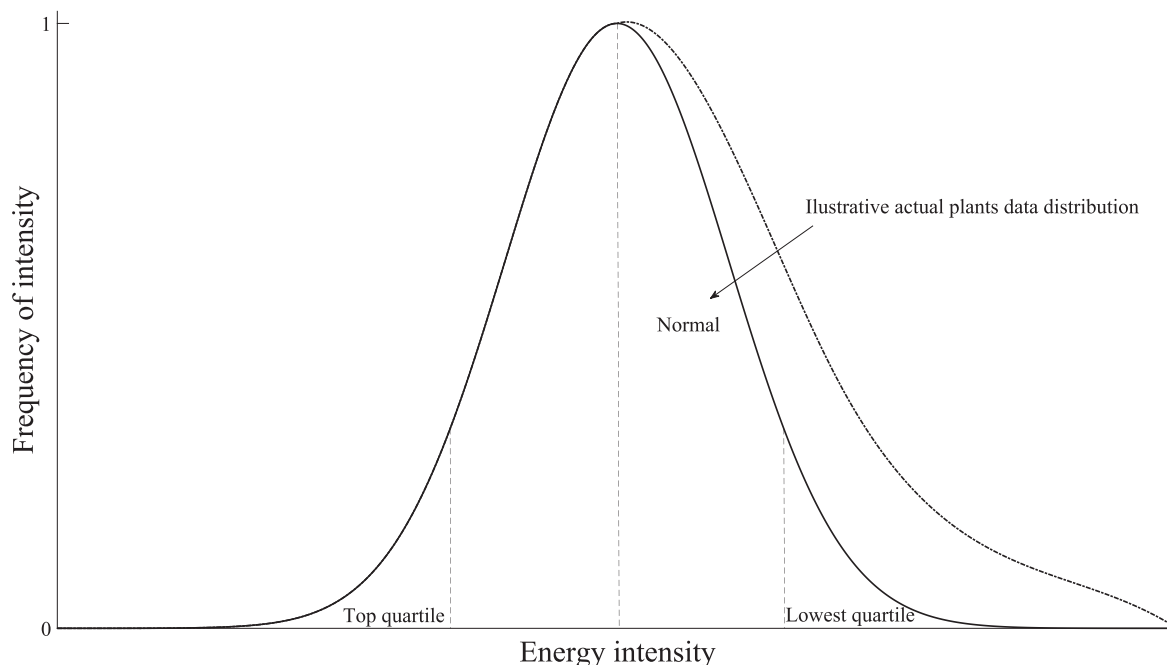

Fig. 7. Normalised frequency or probability distribution of plant energy-intensity and identification of performance improvement opportunities, i.e., of selected portfolio of plants such as olefins.

success by accounting for such practicalities in the framework planning activities. Simultaneously, establishing a time-bound framework could unlock the potential of technologies that accelerate energy efficiency improvements. For instance, investing in technologies that are easily integrated with operational facilities without requiring extensive infrastructural modifications and extended shutdowns can gain momentum because they have the competitiveness of faster deployment. One example of these technologies is integrating waste heat recovery (WHR) technologies so as to minimise inevitable energy losses, which will be covered later in this paper.

5. Finally, as the benchmark framework becomes effective, ensuring new facilities are not deployed unless designed to be best in class is essential in the first place. This can be achieved by organising two-track energy efficiency benchmark targets, one for existing facilities and the other for new facilities, with the latter being stringent.

In summary, the referral to energy efficiency goals is often done interchangeably between design and operational targets, which can be confusing due to several differences between the two. Despite these being two sides of the same coin, it is essential to understand different tools that can be used to analyse and manage off-design performance. In this section, setting operational energy targets has been discussed, and in the next sections, we turn to setting design energy recovery targets. The main difference is that active plants deviate from predicted design performance due to various reasons, and it is advantageous to account for such practicalities and avoid excessive reliance on estimations. Therefore, benchmarking provides unique insights into the real energy efficiency performance of industrial plants and how these are progressing in the transition towards low intensity operations. Multiple global corporations specialise in providing energy benchmarks for various sectors such as refining, fertilisers and bulk chemicals production. However, to maximise the potential of energy benchmarking, a more collective effort between industry and policymakers is needed for less scattered and more streamlined benchmarks that advocate for shared visions and strategies.

### 3. Design improvement studies

Maximising energy efficiency within industrial processes is generally pursued through pinch analysis, which is a systematic approach employing a graphical representation of heat transfer processes between hot and cold streams. It incorporates design parameters such as the minimum approach temperature ( $\Delta T_{\min}$ ) in heat exchangers and estimates the maximum possible energy utilisation within the process ( $Q_{\text{rec}}$ ) and the lowest possible amounts of hot and cold utility imports ( $Q_{\text{Hmin}}$ ) and ( $Q_{\text{Cmin}}$ ), respectively. This concept was first introduced in the 1970 s and has been the golden standard for setting energy targets for process plants since then. The methodology has been extended to cover the domain of heat exchanger network (HEN) design and optimisation, which is typically encountered in grassroots designs and beneficial when retrofitting existing designs [17].

Extensive references on how pinch analysis should be performed are available [18–20]. As shown in Fig. 8(a), composite curves are constructed based on the conditions of hot and cold streams. In the process of drawing the composite curves,  $\Delta T_{\min}$  is determined as a variable that can be optimised, which, together with the stream conditions, gives rise to the composite curve (CC). Once the CC is constructed and the pinch point for the process is determined, it needs to be confirmed that there is no use of hot and cold utilities below and above the pinch point, respectively. Moreover, the CC also can be used to confirm that no heat transfer occurs across the pinch point. These criteria must be met to ensure that no energy inefficiencies inherently exist in the process design.

The grand composite curve (GCC) concept then emerges as a way of providing a representation of the different levels of external utilities required to deliver the duties  $Q_{\text{Hmin}}$  and  $Q_{\text{Cmin}}$  after determining the areas for heat integration (a ‘self-sufficient pocket’) as shown in Fig. 8 (b). By doing so, the maximum possible heat recovery can be determined based on the identified pockets that can be exploited and the integration that can be implemented. The GCC can also be used for appropriate utility selection in terms of temperature and duty levels, such as in the illustration shown in Fig. 8 (c). The CC and GCC are used as the foundation of algorithms to conduct cost-benefit analyses, in order to select the most appropriate energy recovery performance within constraints



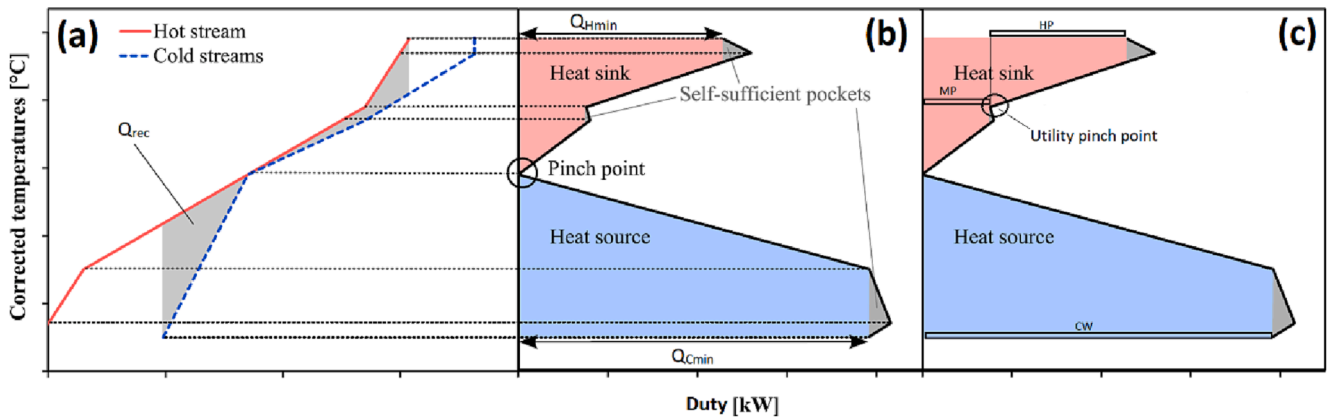

Fig. 8. Illustrations of: (a) a composite curve, (b) a grand composite curve, and (c) utility selection on a grand composite curve; adapted from Ref. [21].

such as environmental/atmospheric conditions and capital expenditure (CAPEX) for process systems.

At sites that encompass multiple processes with a centralised utility system, the analysis can be extended to provide insights on targets and opportunities for maximising heat utilisation and the appropriate utility selection. This is done by conducting a total site analysis by constructing a total site profile (TSP) based on the GCCs of individual processes, which follows a comparable procedure to the CC construction. Yet, TSP involves more extensive data extraction efforts and requires analysing a considerable number of process streams. As a consequence, multiple pieces of software have been developed to automate the steps in pinch analysis procedures and offer optimisation frameworks for process integration studies.

Another aspect of design optimisation is a steam system optimisation, in which the interface between process plants and power produced from heat (by steam), along with heat supply by steam, is optimised. In these studies, the goal is to ensure minimum consumption of fuels and power in the utility production facilities, by influencing how utilities are distributed and consumed, i.e., ensuring that the identified  $Q_{Hmin}$  and  $Q_{Cmin}$  are always minimised, and the co-generation of heat and power is optimised. From a design standpoint, this can be achieved by first designing equipment for generating, transporting, storing and consuming energy efficiently, followed by a steam system designed in a way that leads to the lowest possible consumption of resources.

Fig. 9 illustrates a typical steam balance for a site with a centralised utility system. The following steps need to be achieved for optimal steam

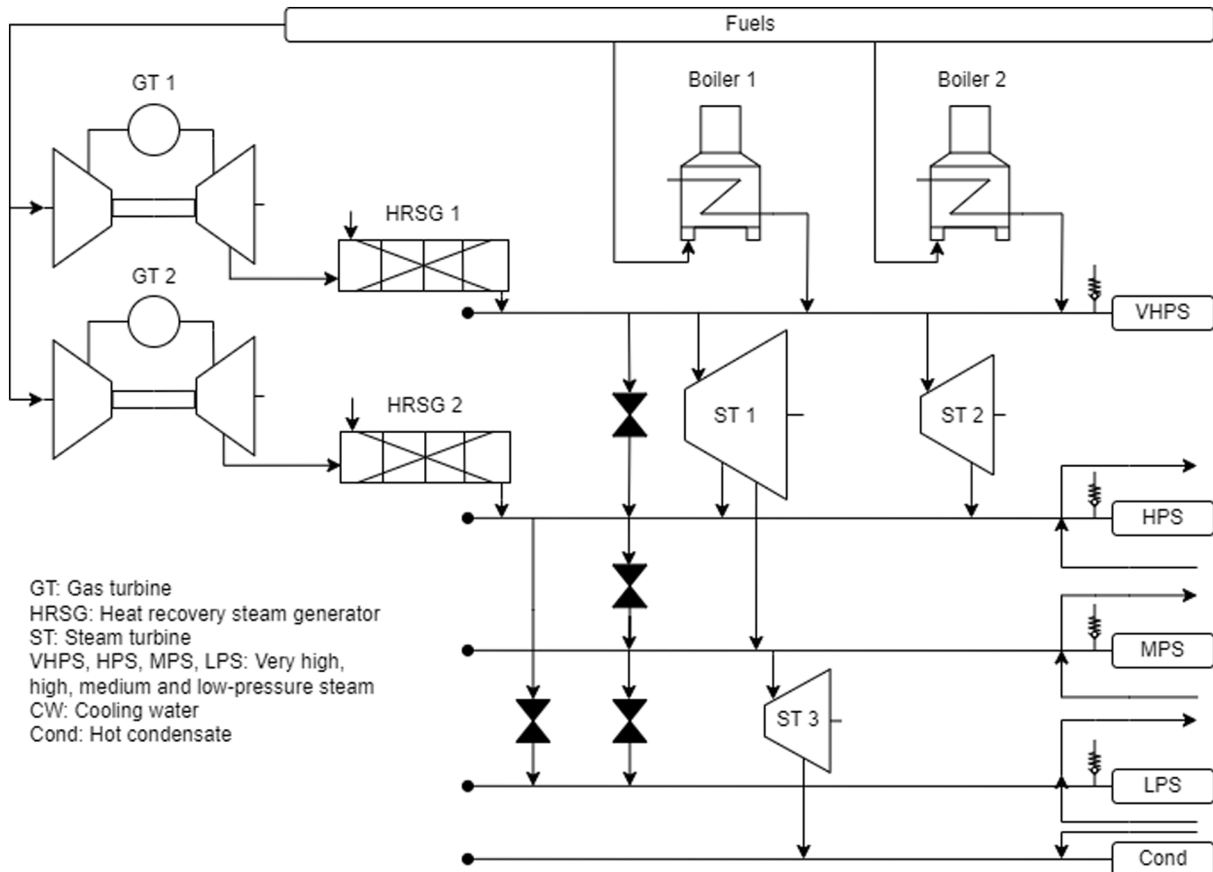

Fig. 9. Illustration of a typical industrial site steam system.

system operation from an energy efficiency perspective [22–27]:

- The system needs to have no steam flow through vents, i.e., no steam header should have excess steam flows. In such cases, a solution is required to offload the steam generation processes with the equivalent amount of steam flowing through vents.
- The system needs to have the flow rates through the let-down valves to lower levels optimised by maximising the let-down through turbines.
- The steam system needs to have minimal condensation of the lowest levels of steam, which will be addressed in Section 4.

Optimising site steam systems often involves solving mathematical equations with a considerable number of variables, and nowadays, the optimisation of these variables is typically performed as part of a computer-aided process. The formulation of the mathematical model starts with modelling the individual components, setting an envelope of conditions (temperature, pressure, etc.) for each of the steam levels, and finally, simulating the entire problem. Since there is a requirement to obtain thermophysical properties for steam and water at different conditions, and the inclusion of part-load scenarios, the problem is typically non-linear. In addition, binary design constraints, such as the availability of turbine-driven or motor-driven pumps/compressors as part of the optimisation, usually make it a mixed-integer non-linear programming (MINLP) problem if more rigorous optimisation is desired. This can be integrated with the benefits of linear programming by incorporating successive mixed-integer linear programming (MILP) [25,27].

An upset or disruption in process plants directly impacts the centralised site utility system, which requires the availability of appropriate steam system balance and optimisation platforms to spot inefficiencies and take the appropriate actions to minimise them. Equally, when conducting energy improvement assessments, steam balances guide decision-making on the site instead of measuring the impact of design or operational changes on the equipment level, which can be misleading [26]. An example of this includes the famous dilemma of selecting the types of drive for mechanical equipment, i.e., pumps and compressors, whether steam-driven or electrically driven. In this case, the second option is generally thought of as the basis for electrification ambitions, as it enables process sites to easier switching to renewable sources of power. However, this needs to be evaluated on the site level because surplus steam may exist, which could be wasted to vent or condensation if the switch is implemented. Furthermore, steam balances provide valuable insights for understanding the impacts of operational activities like equipment maintenance outages on a site's energy efficiency performance.

Therefore, further advancement of energy efficiency performance of process sites requires steam balance models to be constructed, monitored, and optimised. Multiple commercial software algorithms have been developed in this regard, some of which include added features such as linkage with fluid property packages, cost correlations for OPEX and CAPEX estimations, and some even offer real-time optimisation capabilities. However, the concept of steam balance remains fundamentally straightforward to be implemented using spreadsheet calculations. Some challenges arise with modelling existing equipment in old sites where data and performance documents are inaccurate, while in large sites, building a steam system model may involve significant computational problems and data extraction. Several publications and commercial software are available to offer procedural platforms for steam system modelling and optimisation [27–30].

Thus far, our focus has been on hot utility optimisation. However, the cooling utilities may also contribute to substantial energy consumption, emissions, and costs for process sites. Specifically, due to the significant capital and operating costs associated with these systems, sub-ambient cooling by refrigeration needs to be given close attention when optimising plant design and operations. The sub-ambient processes domain of energy efficiency studies was added to the pinch analysis concept by

Dhole and Linnhoff [31], who extended the traditional composite curves to include the exergy element that analyses the trade-off between the shaft power and the cooling capacity supplied. This work is the basis for designing and appropriately placing refrigeration cycles within a process energy system. However, this mainly focuses on systems with a single component as a refrigerant. Other design methodologies are under development, such as complex refrigeration cycles with more than one component and cascade refrigeration cycles. Therefore, the design and retrofit of processes with sub-ambient utility systems should be done with an appreciation of the relationship between the design variables of such systems and the overall site energy efficiency performance. This paper has not dealt with other utilities such as fuel, air, and water. They also potentially contain some overlooked opportunities for improving energy efficiency performance.

In summary, pinch analysis presents itself as a robust methodology for setting energy targets in plants and sites. In existing plants, the main weakness of pinch analysis is the existence of many constraints that may limit the scope for changes, resulting in a lower potential for implementing the theoretical findings of pinch analyses [20]. However, whenever plants are subjected to major revamps that might result in considerable changes to the process design, revising the pinch studies will be a good starting point to assess the potential for energy efficiency of the new plant designs.

#### 4. Residual heat recovery

Thanks to recent advancements in industrial energy efficiency technologies and practices presented earlier in this paper, the process industries have made notable improvements to their energy intensity over the last couple of decades. Nevertheless, there is still a gap to bridge to approach the theoretical minimum energy consumption limits further, which requires identifying the remaining areas where inefficiencies can be addressed. One area that is attracting attention is the exploitation of residual waste heat (RWH) in industrial facilities [32–35]. It is estimated that around 17% of the UK industrial energy consumption ends up as waste heat that is not utilised. Likewise, it is estimated that one-fifth of the industrial energy consumed ends up as waste heat in the US, and that up to 15% of the primary energy consumed in Europe could be reduced by exploiting RWH [33,35–37].

When analysing studies on waste heat recovery (WHR), it is notable that this resource arises and presents itself over various conditions. Therefore, it is beneficial to review different available definitions of waste heat (WH) in the literature and to identify appropriate ones for the energy-intensive process industries. Ammar et al. [38] defined WH to be the heat with a temperature lower than the lowest temperature at which heat recovery is viable, and it has to be hotter than the coldest heat sink by a thermodynamically acceptable difference. Gangar et al. [33] found that this definition yielded the classification of heat sources of temperatures at around 250 °C and lower as WH, which was close to the recommendations of the US Department of Energy and Watt committee. This definition provides good insight, especially for superstructure optimisation frameworks, and can be used to easily guide mathematical models on the distinction between RWH and heat at higher temperatures (grades).

However, this definition is based on the economic viability of heat recovery from different sources, which cannot be standardised as industrial sectors have different standards and hurdle rates to assess commercial viability. Bendig et al. [39] added the element of avoidance potential to the definition mentioned above. The primary motivation for adding this criterion was that it allowed for a differentiation between heat that could be exploited within the process based on pinch analysis and heat that could not be avoided by post-pinch and HEN retrofit analysis. Another definition has been suggested by Oluleye et al. [40,41], who stated that WH was “the residual heat after heat recovery within a process, heat recovery between several processing units on a site, and residual heat rejected to cooling water and air from a site utility

system". Consequently, it can be deduced that RWH classification should not be based on a single criterion, such as temperature, but rather on a site level to maximise heat recovery potential within plants. Also, one often overlooked aspect in assessing the potential of WHR in process industries is the heat wasted during routine and unplanned maintenance downtime. Some chemical production plants, like olefins, methanol, and ethylene glycol, require major shutdowns every 3 to 6 years, which can significantly impact the site's energy intensity. This presents a potential opportunity for temporary onsite or offsite solutions that can convert this intermittency into usable energy products.

There are multiple options for exploiting RWH, depending on the scale and the conditions of the applications of interest. Generally, WH can be used to produce heating [42], cooling [43,44], power [45,46], multi-generation [47,48], fuels [49,50], and other stored forms of energy [51,54]. Also, there are opportunities to export upgraded forms of RWH outside of the industrial facilities through the integration with district heating/cooling networks [52,53]. When conducting RWH studies, proper modelling of each of these technologies is essential, as is keeping all options open at the early stages of the assessment. Some of these technologies have been commercialised, while others still have lower technology or market development maturity.

In this paper, we propose the schematic shown in Fig. 10 to guide the elementary screening efforts of RWH technologies. Fig. 10 provides a brief outline of the different technologies that can be considered in different applications, where under each energy vector, there is usually more than one technology option that can be employed, often with very different characteristics. For instance, the conversion of WH to power can be achieved by either thermo-mechanical heat engines or thermo-electric generators. Also, if the RWH is not at a usable temperature, it could be upgraded to higher temperature levels of thermal energy that match the process requirements using either thermo-mechanical or thermo-chemical Type II heat pumps. Examples of these technologies are vapour compression heat pumping systems and absorption heat transformer systems, respectively. WH could also be converted to cooling utility streams using Type I thermo-mechanical or thermo-chemical heat pumping systems. An example of the first is the conversion of WH to power through heat engines coupled with Type I vapour-compression heat pumps, and the second is absorption chiller systems. Other pathways for converting WH into vectors such as fuels could also be considered.

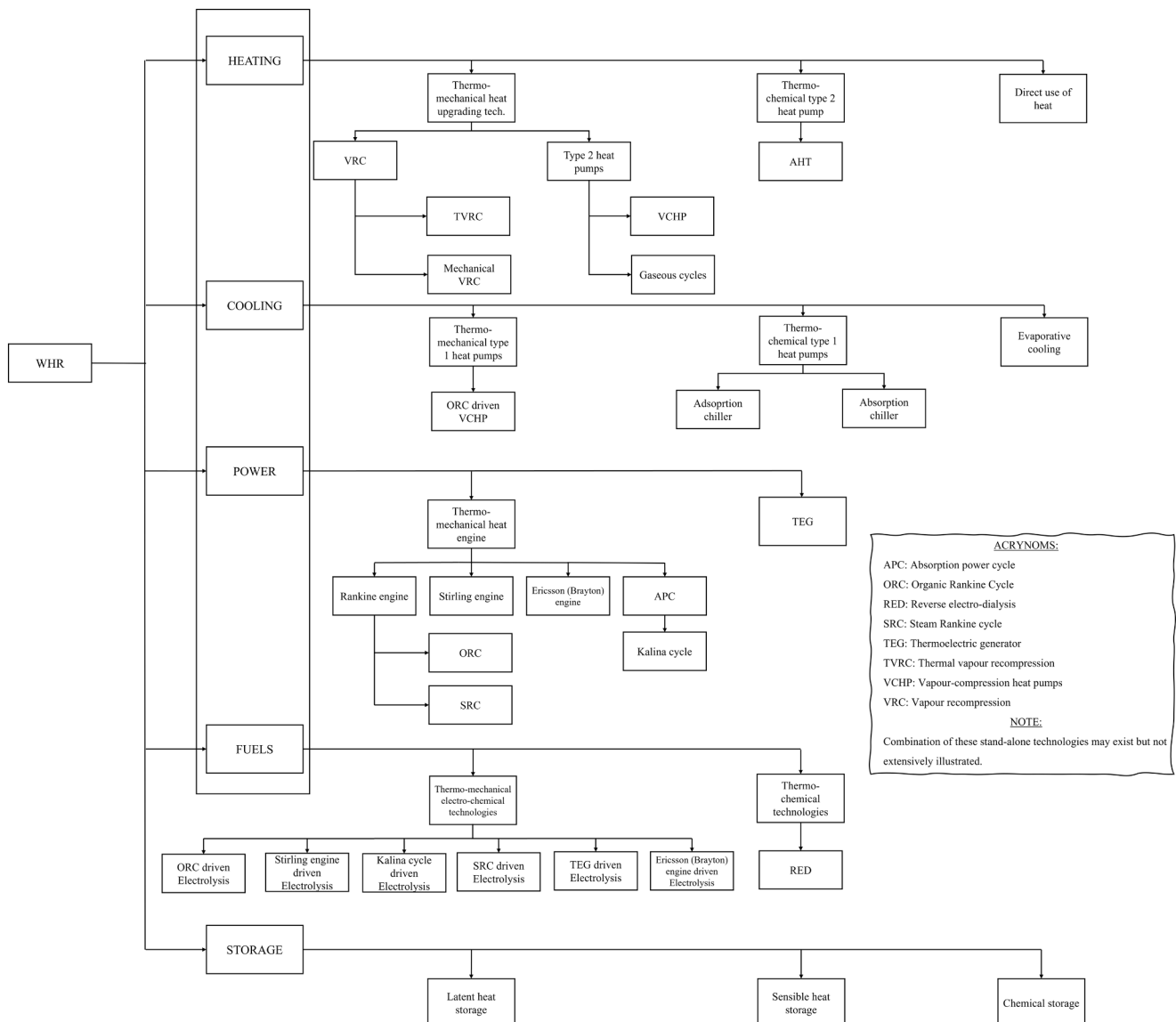

Fig. 10. WHR schemes for the energy-intensive industries that require further R&D.

### 5. Operational energy management programmes

Unfortunately, designing industrial facilities for maximum possible energy efficiency is not enough to guarantee that they will operate accordingly. The dynamism and diversity of industrial operations lead to maintenance outages, performance variability due to weather-related conditions, changes in the portfolios of products and processes, equipment ageing, etc. As a result, having a robust industrial energy management programme is crucial for minimising the effects of such issues and helping to ensure continual energy efficiency performance. The main elements of an industrial energy management programme can be summarised as follows [17,23,55]:

- *Strategic drives:*

The energy management programme starts by establishing a clear policy for the whole organisation regarding energy efficiency. Having a unified strategy enables the embodiment of the different teams within the organisation. Also, the strategy needs to be broken down into specific targets that drive the organisation to undergo activities ranging from operational to investments to achieve them.

- *Organisational elements:*

The implementation of activities for energy management requires the engagement of cross-functional teams from functions such as operations and maintenance of different production lines. Generally, the focus of these teams tends to be paid to the individual process plants rather than the site's integrated energy and emissions performance. The facility energy management is a shared responsibility that can easily get diluted if not appropriately assigned. Therefore, having an organisation with clear roles and responsibilities regarding the site's energy management is crucial for the programme's success.

The energy management team should be responsible for selecting the appropriate tools for managing the site's energy performance. Also, the team may act as the accountable body for implementing real-time optimisation actions flagged by the available tools. Energy issues such as steam leaks, which can significantly impact the performance and require preventive measures, can also be followed up by the team.

Another important aspect of the responsibilities of the energy team is building awareness and fostering a culture of paying attention to energy key variables.

- *Progress reviews:*

Along the way to achieving the strategy, a variety of dynamics are anticipated to affect the plan. Consequently, periodic progress reviews need to be conducted, which requires the development of reports based on data. Effective communication between the stakeholders and the decision-makers needs to be included in a robust programme to ensure achieving continuous improvements.

### 6. Future outlook

In view of the foregoing, the main pathways for decarbonising energy-intensive industries suggested in the proposed framework are summarised in Fig. 11. Maximising the efficiency of process systems designs requires incorporating the evaluation of process integration opportunities to be part of the management of change procedures when investing in system design projects that impact the energy mix of the facility. Also, further research and development work is required to advance technologies and applications for residual waste heat recovery that are focused on the industry.

Furthermore, operational energy-optimisation tools are required to aid real-life and off-design energy efficiency performance management. Advanced data-driven and predictive optimisation algorithms that have the capabilities of minimising the impacts of deviations and outages on energy efficiency are required to improve the actual energy-efficiency performance. In addition, the actual performance needs to be compared to benchmarking data to ensure that best-in-class is pursued.

Lastly, a crucial aspect of energy and emissions benchmarking that was not extensively covered in this work is product footprint benchmarking, which has recently gained momentum as an emerging key differentiator among manufactured products. Product footprint benchmarking involves extended resource consumption and emissions data analysis beyond the boundaries of industrial facilities [56]. This can be achieved with life cycle analysis (LCA), which considers the footprint of the entire supply chain [57,58].

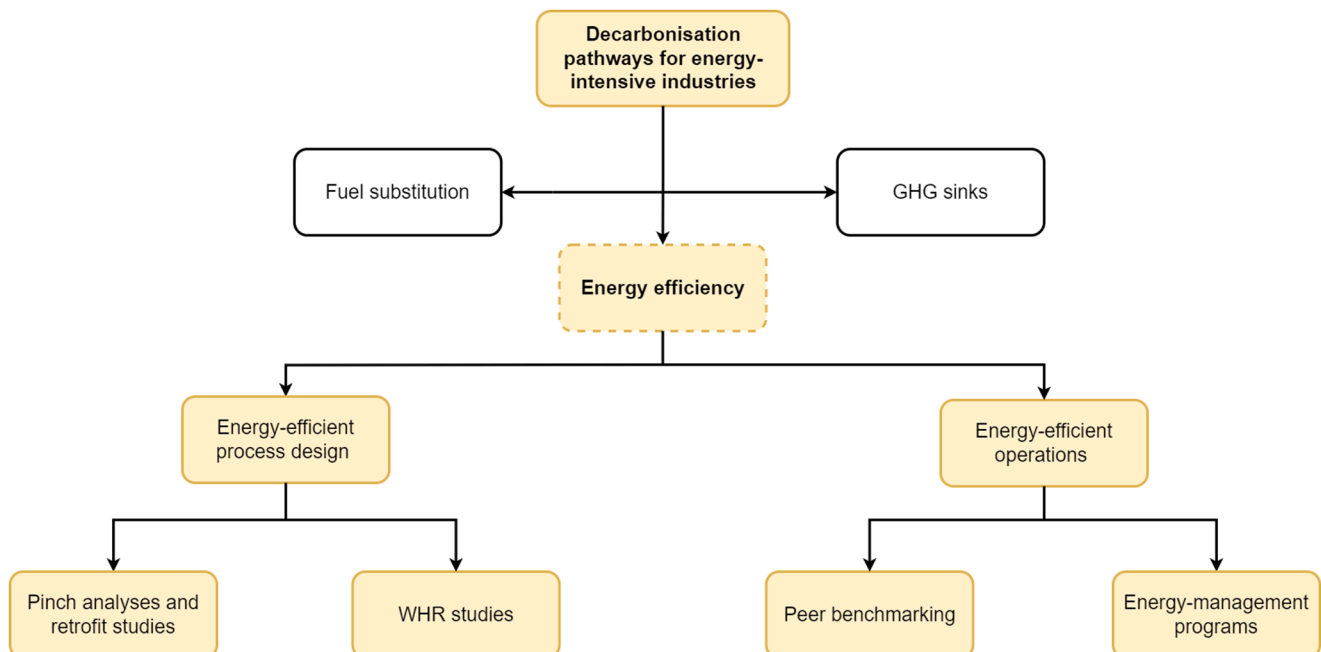

Fig. 11. Pathways to decarbonisation acceleration through energy efficiency.

## 7. Conclusions

Energy efficiency is a crucial part of the ongoing industrial decarbonisation transition due to important benefits covering environmental protection, economic sustainability, and social gains that come from energy abundance resulting from energy conservation efforts. The industrial sector is a vital enabler of maintaining and improving prosperity because its products have a prolonged impact on our lives. Therefore, it is essential to embed energy efficiency as part of the business model for industries. In this paper, suggestions have been made, assembled in an integrated framework, for achieving continuous energy efficiency improvements in industrial facilities, along with a summary of relevant state-of-the-art tools, techniques and technologies that can achieve such a goal.

This vision paper proposes a new guide to the industrial energy efficiency landscape by adopting a system-level thinking approach that considers the broader context of decarbonisation. By emphasising the importance of integrating energy efficiency measures with decarbonisation objectives, we address the critical need for reducing emissions in the industrial sector. We also recognise the crucial role of stakeholder engagement and effective energy management in achieving these objectives, as well as identifying key research challenges and opportunities that can drive innovation in this area.

The main contribution of this paper, and where it goes beyond previous work in the literature, is in developing and proposing a novel holistic framework that is recommended as a guide for the continuous decarbonisation of thermal-energy-intensive industries through the series of energy efficiency measures and actions. In particular, we suggest to initiate energy-efficiency efforts by applying a top-down peer benchmarking approach to identify the gaps in energy-efficiency performance at the products, plants, processes and equipment levels. After this stage, we proposed a series of steps to close the identified energy-efficiency gaps across these levels using tools such as pinch analysis, steam system optimisation and residual waste heat recovery for which we suggest a portfolio of potential schemes that can exhibit benefits at acceptable costs. We also propose to simultaneously turn to operational energy management programs with a sequence of recommended actions that minimise deviations from the targeted energy-efficiency performance.

The above elements require an effective collaboration between industry, academia, research organisations, and policymakers. Exchanging best practices, technological advancements and reliable data all contribute to accelerating the progression towards higher efficiency and lower resource consuming operations. The presented framework can serve as a practical guide for stakeholders to identify tools and appropriate solutions through to attain continuously improved energy efficiency performance and to achieve decarbonisation in the industrial sector. It provides insight and guidance to industrial facility operators, owners, plant managers, and the wider energy system stakeholders.

## Declaration of Competing Interest

The authors declare that they have no known competing financial interests or personal relationships that could have appeared to influence the work reported in this paper.

## Data availability

Data will be made available on request.

## Acknowledgement

The authors would like to acknowledge the Saudi Basic Industries Corporation (SABIC) for providing the financial support to conduct this research. This work was supported by the UK Engineering and Physical

Sciences Research Council (EPSRC) [grant numbers EP/R045518/1, and EP/S032622/1]. The authors also would also like to acknowledge Dr. Paul Sapin for his help in the development of the WHR schemes chart. Data supporting this publication can be obtained on request from cep-lab@imperial.ac.uk. For the purpose of Open Access, the authors have applied a CC BY public copyright licence to any Author Accepted Manuscript version arising from this submission.

## References

- [1] Trading economics website, available at: <https://tradingeconomics.com>.
- [2] British Petroleum (BP). BP Energy Outlook, 2019.
- [3] International Energy Agency (IEA). Energy Technology Perspectives, 2017.
- [4] The European Chemical Industry Council (CEFIC). Landscape of The European Chemical Industry, 2020.
- [5] The European Chemical Industry Council (CEFIC). Facts and Figures of the European Chemical Industry, 2022. <https://cefic.org/a-pillar-of-the-european-economy/facts-and-figures-of-the-european-chemical-industry>.
- [6] T.A. Napp, A. Gambhir, T.P. Hills, N. Florin, P.S. Fennell, A review of the technologies, economics and policy instruments for decarbonising energy-intensive manufacturing industries, *Renew. Sustain. Energy Rev.* 30 (2014) 616–640, <https://doi.org/10.1016/j.rser.2013.10.036>.
- [7] Vallejo L., et al., Halving global CO2 by 2050: technologies and costs, 2013.
- [8] T. Ren, M. Patel, K. Blok, Olefins from conventional and heavy feedstocks: Energy use in steam cracking and alternative processes, *Energy* 31 (4) (2006) 425–451, <https://doi.org/10.1016/j.energy.2005.04.001>.
- [9] A.G. Hernandez, J.M. Cullen, Exergy: A universal metric for measuring resource efficiency to address industrial decarbonisation, *Sustain. Prod. Consum.* 20 (2019) 151–164, <https://doi.org/10.1016/j.spc.2019.05.006>.
- [10] KBC (a Yokogawa Company). Industrial Energy Transition Manifesto, 2019.
- [11] G.P. Thiel, A.K. Stark, To decarbonize industry, we must decarbonize heat, *Joule* 5 (2021) 531–550, <https://doi.org/10.1016/j.joule.2020.12.007>.
- [12] Rissman J., et al., Technologies and policies to decarbonize global industry: Review and assessment of mitigation drivers through 2070, *Appl. Energy*, vol. 266, no. November 2019, p. 114848, 2020. <https://doi.org/10.1016/j.apenergy.2020.114848>.
- [13] International Energy Agency (IEA). Energy Technology Perspectives, 2006.
- [14] U.S. Department of Energy, Steps to Develop a Baseline: A Guide to Developing an Energy Use and Energy Intensity Baseline and the Reporting Requirements for the Save Energy Now LEADER Pledge. <https://www1.eere.energy.gov/manufacturing/resources/pdfs/leaderbaselinesteps guideline.pdf>.
- [15] The International Standards Organisation (ISO). ISO 50006: Energy Management Systems - Measuring Energy Performance Using Energy Baselines (EnB) and Energy Performance Indicators (EnPI) - General Principles and Guidance, 2016.
- [16] H. Cervo, J.-H. Ferrasse, B. Descales, G. Van Eetvelde, Blueprint: A methodology facilitating data exchanges to enhance the detection of industrial symbiosis opportunities—application to a refinery, *Chem. Eng. Sci.* 211 (2020), 115254, <https://doi.org/10.1016/j.ces.2019.115254>.
- [17] F. Kreith, D.Y. Goswami, *Handbook of Energy Efficiency and Renewable Energy*, First edition, CRC Press LLC, 2007.
- [18] B. Linnhoff, D. Boland, *A user guide on process integration for the efficient use of energy*, Second edition, Elsevier Ltd., Oxford, 1982.
- [19] R. Smith, *Chemical Process Design and Integration*, Second edition, Wiley, Chichester, 2016.
- [20] I.C. Kemp, *Pinch analysis and process integration: a user guide on process integration for the efficient use of energy*, Second edition, Elsevier, 2007.
- [21] A.S. Wallerand, *Integration of Solar Energy with Industrial Processes*, École Polytechnique Fédérale, De Lausanne, 2018.
- [22] P. Velasco-Garcia, P. Varbanov, H. Arellano-Garcia, G. Wozny, Utility systems operation: Optimisation-based decision making, *Appl. Therm. Eng.* 31 (16) (2011) 3196–3205, <https://doi.org/10.1016/j.applthermaleng.2011.05.046>.
- [23] A.P. Rossiter, B.P. Jones, *Energy Management and Efficiency for the Process Industries*, John Wiley & Sons Inc, Hoboken, 2015.
- [24] P.S. Varbanov, S. Doyle, R. Smith, Modelling and optimization of utility systems, *Chem. Eng. Res. Des.* 82 (5) (2004) 561–578, <https://doi.org/10.1205/026387604323142603>.
- [25] P. Varbanov, S. Perry, J. Klemes, R. Smith, Synthesis of industrial utility systems: Cost-effective de-carbonisation, *Appl. Therm. Eng.* vol. 25, no. 7 Spec. Iss (2005) 985–1001, <https://doi.org/10.1016/j.applthermaleng.2004.06.023>.
- [26] L. Sun, C. Liu, Reliable and flexible steam and power system design, *Appl. Therm. Eng.* 79 (2015) 184–191, <https://doi.org/10.1016/j.applthermaleng.2014.11.076>.
- [27] P.S. Varbanov, J. Skorpik, J. Pospisil, J.J. Klemes, *Sustainable Utility Systems : Modelling and Optimisation*, De Gruyter, Berlin/Boston, 2021.
- [28] Process Integration Limited (PIL). i-Steam product. <https://www.processint.com/software/i-steam>.
- [29] Aspen Technology, Aspen utilities product. <https://www.aspentech.com/en/products/engineering/aspen-utilities>.
- [30] Process Systems Engineering (PSE). gPROMS utilities advisor and planner. <https://www.psenterprise.com/solutions/gutilities>.
- [31] V.R. Dhole, B. Linnhoff, Overall design of low temperature processes, *Comput. Chem. Eng.* 18 (1994) S105–S111, [https://doi.org/10.1016/0098-1354\(94\)80018-9](https://doi.org/10.1016/0098-1354(94)80018-9).



- [32] X. Zhou, et al., Comparative study for air compression heat recovery based on organic Rankine cycle (ORC) in cryogenic air separation units, *Energy* 225 (2022), <https://doi.org/10.1016/j.energy.2022.124514>.
- [33] N. Gangar, S. Macchietto, C.N. Markides, Recovery and utilization of low-grade waste heat in the oil-refining industry using heat engines and heat pumps: An international technoeconomic comparison, *Energies* 13 (10) (2020) pp, <https://doi.org/10.3390/en13102560>.
- [34] J. Song, X. Li, K. Wang, C.N. Markides, Parametric optimisation of a combined supercritical CO<sub>2</sub> (S-CO<sub>2</sub>) cycle and organic Rankine cycle (ORC) system for internal combustion engine (ICE) waste-heat recovery, *Energy Convers. and Manag.* 218 (2020), <https://doi.org/10.1016/j.enconman.2020.112999>.
- [35] C.N. Markides, The role of pumped and waste heat technologies in a high-efficiency sustainable energy future for the UK, *Appl. Therm. Eng.* 53 (2) (2013) 197–209, <https://doi.org/10.1016/j.applthermaleng.2012.02.037>.
- [36] BSC Incorporated. Waste Heat Recovery: Technology Opportunities in the US Industry, 2008.
- [37] Element Energy Limited. The Potential for Recovering and Using Surplus Heat from Industry, 2014.
- [38] Y. Ammar, S. Joyce, R. Norman, Y. Wang, A.P. Roskilly, Low grade thermal energy sources and uses from the process industry in the UK, *Appl. Energy* 89 (1) (2012) 3–20, <https://doi.org/10.1016/j.apenergy.2011.06.003>.
- [39] M. Bendig, F. Maréchal, D. Favrat, Defining waste heat for industrial processes, *Appl. Therm. Eng.* 61 (1) (2013) 134–142, <https://doi.org/10.1016/j.applthermaleng.2013.03.020>.
- [40] G. Oluleye, M. Jobson, R. Smith, A hierarchical approach for evaluating and selecting waste heat utilization opportunities, *Energy* 90 (2015) 5–23, <https://doi.org/10.1016/j.energy.2015.05.086>.
- [41] G. Oluleye, M. Jobson, R. Smith, J.S. Perry, Evaluating the potential of process sites for waste heat recovery, *Appl. Energy* 161 (2016) 627–646, <https://doi.org/10.1016/j.apenergy.2015.07.011>.
- [42] J. Fitó, et al., Energy- and exergy-based optimal designs of a low-temperature industrial waste heat recovery system in district heating, *Energy Convers. and Manag.* 211 (2020), <https://doi.org/10.1016/j.enconman.2020.112753>.
- [43] G. Maouris, E.J.S. Escriva, S. Acha, N. Shah, C.N. Markides, CO<sub>2</sub> refrigeration system heat recovery and thermal storage modelling for space heating provision in supermarkets: An integrated approach, *Appl. Energy* 264 (2020), <https://doi.org/10.1016/j.apenergy.2020.114722>.
- [44] Y. Liang, Z. Yu, W. Li, A Waste Heat-Driven Cooling System Based on Combined Organic Rankine and Vapour Compression Refrigeration Cycles, *Appl. Sci.* 9 (20) (2019) pp, <https://doi.org/10.3390/app9204242>.
- [45] S. Lecompte, et al., Case Study of an Organic Rankine Cycle (ORC) for Waste Heat Recovery from an Electric Arc Furnace (EAF), *Energies* 10 (5) (2017) pp, <https://doi.org/10.3390/en10050649>.
- [46] F. Fatigati, D. Vittorini, Y. Wang, J. Song, C.N. Markides, R. Cipollone, Design and operational control strategy for optimum off-design performance of an ORC plant for low-grade waste heat recovery, *iEnergies* 13 (21) (2020) pp, <https://doi.org/10.3390/en13215846>.
- [47] A.M. Pantaleo, J. Fordham, O.A. Oyewunmi, P. De Palma, C.N. Markides, Integrating cogeneration and intermittent waste-heat recovery in food processing: Microturbines vs. ORC systems in the coffee roasting industry, *Appl. Energy* 225 (2018) 782–796, <https://doi.org/10.1016/j.apenergy.2018.04.097>.
- [48] A.S. Kalan, H. Ghiasirad, R.K. Saray, S. Mirmasoumi, Thermo-economic evaluation and multi-objective optimization of a waste heat driven combined cooling and power system based on a modified Kalina cycle, *Energy Convers. and Manag.* 247 (2021), <https://doi.org/10.1016/j.enconman.2021.114723>.
- [49] H. Ishaq, I. Dincer, G.F. Naterer, New trigeneration system integrated with desalination and industrial waste heat recovery for hydrogen production, *Appl. Therm. Eng.* 142 (2018) 767–778, <https://doi.org/10.1016/j.applthermaleng.2018.07.019>.
- [50] F. Wang, L. Wang, H. Zhang, L. Xia, H. Miao, J. Yuan, Design and optimization of hydrogen production by solid oxide electrolyzer with marine engine waste heat recovery and ORC cycle, vol. 229, 2021. <https://doi.org/10.1016/j.enconman.2020.113775>.
- [51] Y. Zhao, et al., Thermo-economic assessments of pumped-thermal electricity storage systems employing sensible heat storage materials, *Renewable Energy* 186 (2022) 431–456, <https://doi.org/10.1016/j.renene.2022.01.017>.
- [52] F. Bühler, et al., Spatiotemporal and economic analysis of industrial excess heat as a resource for district heating, *Energy* 151 (2018) 715–728, <https://doi.org/10.1016/j.energy.2018.03.059>.
- [53] K. Pettersson, et al., Holistic methodological framework for assessing the benefits of delivering industrial excess heat to a district heating network, vol. 44, pp. 2634–2651, 2020. <https://doi.org/10.1002/er.5005>.
- [54] L. Miró, J. Gasia, F. Gabeza, Thermal energy storage (TES) for industrial waste heat (IWH) recovery: A review, *Appl. Energy* 179 (2016) 284–301, <https://doi.org/10.1016/j.apenergy.2016.06.147>.
- [55] D. Kaya, K.F. Çanka, H.H. Öztürk, *Energy management and energy efficiency in industry practical examples*, first ed., Springer International Publishing, Cham, 2021.
- [56] J. Barrett, T. Cooper, G.P. Hammond, N. Pidgeon, Industrial energy, materials and products: UK decarbonisation challenges and opportunities, *Appl. Therm. Eng.* 136 (2018) 643–656, <https://doi.org/10.1016/j.applthermaleng.2018.03.049>.
- [57] A. Azapagic, S. Perdan, *Sustainable Development in Practice: Case Studies for Engineers and Scientists*, Second Edition, Wiley-Blackwell, 2011.
- [58] J.J. Klemes, *Assessing and measuring environmental impact and sustainability*, first ed., Butterworth-Heinemann, Oxford, 2015.