

Shurooq T. AL-Hemeri

Department of Chemical
Engineering, University of
Technology, Iraq, Baghdad
salhemi2004@yahoo.com

Riyadh S. AL-Mukhtar

Department of Chemical
Engineering, University of
Technology-Iraq, Baghdad.

Lina W. Mahmood

Department of Chemical
Engineering, University of
Technology-Iraq, Baghdad

Received on: 16/09/2018

Accepted on: 10/01/2019

Published online: 25/04/2019

Thermodynamic and Kinetic Investigation of Desalination by Refrigerant Clathrate Hydrate Formation

Abstract-Gas hydrate is a crystalline solid compound form of water with hydrophobic gas at certain conditions (pressure and temperature). The hydrogen bond in water molecules constructs a framework as a host that entraps gas molecules (guest). Gas hydrate can be applied to many industries such as gas separation, cool storage, food concentration and desalination. Hydrate route looks a promising alternative technology compared to the conventional process, by utilizing a proper gas host, which can be held within water cavities composed by hydrogen-bonded water molecules. In this study the selected host gas was Refrigerant R134a, the work consists of an experimental and theoretical investigation dealing with hydrate formation for the ternary system (water, refrigerant gas, salt) at different initial pressures, the salts were NaCl, KBr and NaF. Method of isochoric pressure search method was used to measure the pressure and temperature for hydrate formation and conduction the three phases of (hydrate-liquid-vapour). The measurements were performed with pressure range (0.1 - 0.4) MPa and the temperatures about (275.2 – 283)K at the concentrations of (0.09, 0.17 and 0.26) mol/kg for each salt. The kinetics of R134a clathrate formation for ternary systems (R134a, water and salt) at various types and concentrations of salts. Many objective functions were obtained from the kinetic model for hydrate formation, such as the amount of gas consumed, the growth rate, and the conversion of the water to hydrate. The results showed the effect of the initial pressure on the gas consumed, the rate of growth and water to hydrate conversion, that when the initial pressure increases the moles of R134a gas consumed was increased due to the increased driving force of hydrate formation, also other functions were increased. While the increasing in the concentration of salt for all types will be decreased gas consumed, whereas water to hydrate conversion, the growth rate is slightly decreased. And from the results noticed the presence of different salts in the ternary systems have an effect on the thermodynamics inhibition of refrigerant hydrates and the inhibition increases with the presence of NaCl salt in the ternary system more than other types of salts and also increases with increase the concentration of salt.

Keywords- Gas clathrate, refrigerant guest, kinetics, thermodynamics inhibition, ternary systems, salts.

How to cite this article: S.T. AL-Hemeri, R.S. AL-Mukhtar and L.W. Mahmood, "Thermodynamic and Kinetic Investigation of Desalination by Refrigerant Clathrate Hydrate Formation," *Engineering and Technology Journal*, Vol. 37, Part C, No. 1, pp. 29-44, 2019.

1. Introduction

Gas hydrates or clathrates hydrate are crystalline solid compound physically resembling ice form when sufficient amount of water with small non-polar molecules (typically gases) present at a suitable condition, the expectation of hydrate formation increased at high pressure and low temperature [1]. The molecules of water are known as the (host) because of the hydrogen bonds construct a framework that entraps the gas molecules, which name the (hydrate former) or (guest) [2]. When light gases like methane or ethane contact with water at high pressure and low temperature close to the freezing point of water gas hydrate can be crystallized. The light gases may

enter and stabilize in small and large cavities whose molecular diameter is less than the diameter of the cavity of water molecules lattices. The oil and gas industries are familiar with hydrate deposits in pipes and equipment that carry natural gas when liquid water is present [3]. Recently, gas hydrates have been increasingly developed at different fields that related to gas transportation, water desalination and energy storage, also the different studies, which concern with the hydrate problems that involve the thermodynamics, kinetics and mass and heat transfer for the formation of hydrate and dissociation [4]. The more commonly studies of hydrates guest molecules are for the light hydrocarbons like

<https://doi.org/10.30684/eti.37.1C.6>

2412-0758/University of Technology-Iraq, Baghdad, Iraq

This is an open access article under the CC BY 4.0 license <http://creativecommons.org/licenses/by/4.0>

propane and isobutene and most low molecular weight gases, including hydrogen, CO₂, hydrogen sulfide and nitrogen [5]. Refrigerant hydrates can be formed at lower temperature and under low pressures and can be considered in the desalination process, also favorable materials for energy storage, and that considered favorable in air conditioning systems. The most general refrigerants, which used in the industry, are about three types, which included CFC (chlorofluorocarbon), HCFC (hydro chlorofluorocarbon) and HFC (hydrofluorocarbon). The CFC refrigerants, like R11 and R12 are used as an appropriate media for applications of cold storage, but these refrigerants have been limited by the Montreal Protocol because of their high ozone depletion potential (ODP). Chlorofluorocarbon (CFC) is replaced by development alternatives to protect the world's environment. Hydrofluoro carbons (HFCs) are compounds that do not contain chlorine and are selected as a good alternative for CFC [6]. The first consideration taken on the choice of commercial fluorinated hydrating agents was dependent on a number of factors; these included tests, as well as similarities in structure between gases. The best factors in the choice of commercial fluorinated are availability, low cost, non-toxicity, non-flammability, chemical stability and suitable operating temperature and pressure resulted in lower operating costs [7]. R134a refrigerant has all these factors, which make it the best commercial fluorinate. R134a (1, 1, 1,2-tetrafluoroethane) famous as Freon, or HFC-134a, is a haloalkane refrigerant with thermodynamic properties identical to R-12 (dichlorodifluoromethane). It has the formula CH₂FCF₃ and a boiling point of -26.3 °C (-15.34 °F) at the atmospheric pressure [8]. The process of hydrate formation is a crystallization process, which has many similarities with that of as crystallization; also, it is a stochastic phase change that requires a supersaturated environment to happen. Gas solubility has a significant influence on the hydrate formation rate and equilibrium pressure, the solubility of gas increases with decreasing temperature [9]. The hydrate formation process involves two phases to occur. The nucleation is one of the phases includes the nuclei of hydrate formation. Hydrate growth is the second phase, which represents the growth of stable nuclei [10]. The T cycle of formation and dissociation of R134a refrigerant hydrate, as shown in Figure 1 may be used as a stand by technology to the desalination of salty water instead of the traditional process, like that reverse osmosis (RO) and multistage flash (MSF) distillation[11]. Some of

the researchers mentioned that the presence of salts did not inter in the crystalline structure of the hydrates by using microscopic analyses (NMR)nuclear magnetic resonance and (PXRD)powder X-ray diffraction, because the salts did not contribute in the constructing of hydrate cages, as shown in the Figure 2 [12]. This technology of gas hydrate has been shown to be so promising because water and a suitable refrigerant enable to form hydrate at moderate temperatures and low pressure. The hydrate produced can be dissociated later to obtain pure water and refrigerant which can be recycled into the system [13]. Because of low operating temperatures, scaling, corrosion and fouling are reduced. The materials used in desalination may be had low cost due to the low operating temperature compared to (MED) multi-stage flash evaporation desalination [14].

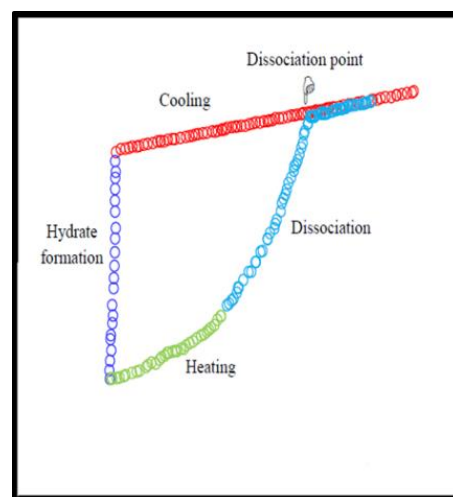

Figure1: Isochoric search technique [15]

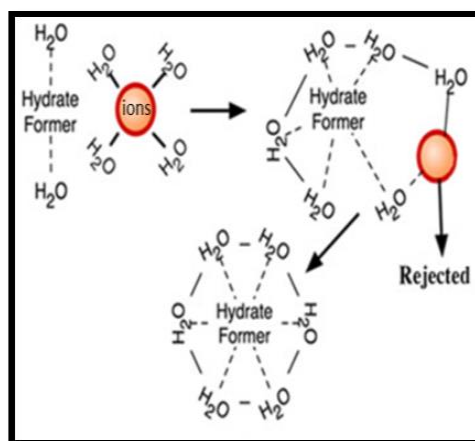

Figure 2: Basic of hydrate desalination. [12]

Bradshaw evaluated the formation of a clathrate hydrate experimentally by using various gases (guest molecules) that include R141b (C₂FCl₂H₃) and ethylene where is the guest of a gaseous hydrate, easily formed hydrates in presence of salty water above to 5°C and 20 atm [16].

Karamoddin and Vartanian studied the process of hydrate growth for R141b in various salty solutions to desalinate the saline water [8]. Kinetic experiments were applied with initial temperatures of 0, 2, and 4°C with 1, 2, 4, and 6% weight of NaCl and also with the molarity 0.304mol/L of NaCl, KCl, CaCl₂, and MgCl₂ in system forming to hydrate. Each dissolved mineral is removed in the following order: K¹⁺>Na¹⁺>Ca²⁺>Mg²⁺ with 59–70% of efficiency. Jeong et al. focused on their experimental study to design a hydrate formation reactor to produce R134a hydrate slurry for economic application in desalination of seawater by applying gas hydrate technology [17]. Lee et al. investigated the effect of presence NaCl in the system forming to hydrate on the thermodynamic hydrate condition to the R-134a hydrate, the systems consisting of the R-134a+ (0, 3.5, and 8.0 wt%) of NaCl+ water were measured by using isochoric (pVT) method and a stepwise differential scanning calorimeter (DSC) method [18].

Advantages of clathrate hydrate method are:

1. It proves advantageous due to its low energy requirement: the latent heat of fusion of ice is one-seventh of the latent heat of vaporization of water, that's making it suitable for hydrate desalination technology.
2. A high heat transfer coefficient and surface area may be achieved as there is a direct contact between the brine and the refrigerant.

The main purpose of this work can be briefed in the following steps:-

I. Studying the phenomena of hydrate formation of refrigerant R134a for the binary system (water +R134a) and ternary system (water +R134a + salt) for different types of salt at different concentrations.

II. Initiating a semi-empirical model to explain the hydrate formation of the binary system and ternary systems and building a computer program to calculate these parameters :

- a. The gas consumed (Δn) in the formation of the hydrate.
- b. The growth rate ($r(t)$).
- c. The conversion of water to hydrate.

2. Experimental Work

The experimental work including the thermodynamic conditions of clathrate hydrate formation for the binary system consists of (refrigerant R134a, water) and ternary system comprising (refrigerant R134a, water and salt). Three types of salts (NaCl, KBr, and NaF) were used in this study. The main chemical materials used in this work are refrigerant gas R134a, distilled water and electrolytes.

Test rig of refrigeration system with clathrate hydrate cell was built in the present work to perform the experimental tests as shown in Figures 3 and 4.

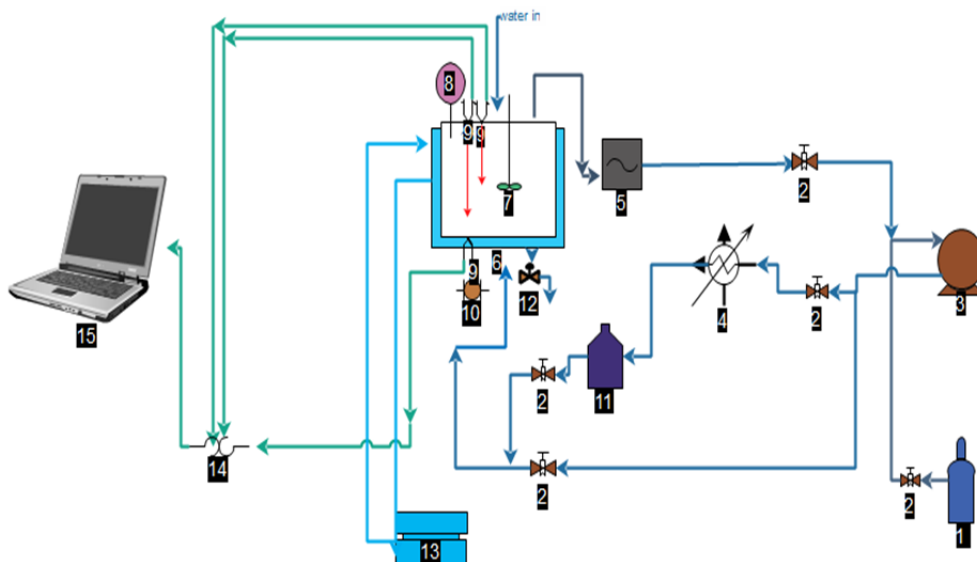

Figure 3: Simplified schematic of the experimental setup: (1) R134a refrigerant container ; (2) needle valve; (3) gas compressor; (4) condenser; (5) accumulator; (6) Experimental cell; (7) mechanical stirrer; (8) pressure gauges; (9) thermocouples; (10) valve ; (11) gas collection cylinder; (12) valve drain (13) chiller; (14) interface system; (15) computer.



Figure 4: The experimental test rig

The experimental cell is a glass cylinder having internal diameter 14.0 cm, outer diameter 14.5cm and height 14.5 cm; the total volume is about 1.5 L. The top and the bottom cover are carbon steel plates. The top cover contains six openings. The first is for water input and the second is for the stirrer. Two other openings are used for inserting thermocouples inside the cell. The fifth hole is for the cell evacuation. The last one is for the pressure gauge. The bottom plate has two openings, one for gas input and the second used to discharge the cell content. The cell is surrounded by a jacket made of transperance plastic and filled with cold water supplied by water bath type Julabo F10-VC; to ensure maintaining the isothermal environment.

a. Cell preparation: In order to remove any pollution from the cell contents, it should be cleaned prior to undertaking any experimental measurements. Initially, the cell was filled by distilled water about 400 ml, and then water was allowed to stirrer inside the cell with a speed of 400 rpm for 10 minutes to remove any impurities present on the cell wall. Thereafter, the water was drained from the cell. This step were repeated two times to ensure removing the impurities, after that the cell was emptied from the air by the compressor at a pressure of (-0.0089) bar for 10 minutes.

b. Cell loading: When the cell was adequately cleaned, the distilled water or salt aqueous solution

was drawn into a hosepipe. The entrance valve of the cell was connected to the filled hosepipe and opened to let the aqueous solution or distilled water enters to the cell. The air in the cell was discharged by the compressor at pressure (-0.0089) bar and for 10 minutes. The cell was surrounded by the temperature controlled jacket in which the temperature was set to lower temperature. Then, the cell was loaded with R134a gas pressurized to the desired pressure.

When the system reached to the desired pressure, the stirrer was run on and set to 250 rpm. Then, a slow decrease was noticed in the temperature to facilitate the nucleation of hydrates visually. The pressure was then decreased gradually with increasing of hydrate formation till reaching a fixed value that the pressure was stabilized. After that, the temperature of the cell increased slowly by increasing water bath temperature in a stepwise manner that leads to hydrate dissociation, also temperature and pressure were recorded till returning to the initial pressure and temperature .

The temperature and pressure were recorded at each 4 minutes interval till reaching to lowest pressure, and the measurement procedures are:

I. The visual observations through the cell side were taken by photographic pictures through the formation stages, as shown in Figure 5:

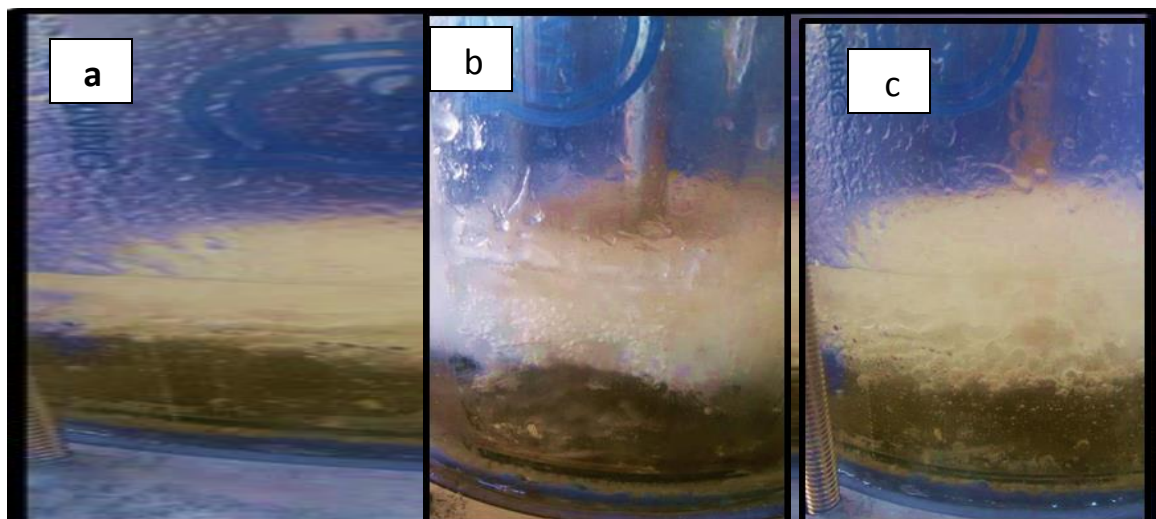

Figure 5: Visual observations of hydrate formation

II. The same procedure was used with different initial pressures (0.42, 0.3, 0.25, 0.21) MPa for the binary system (R134a + water); in order to obtain the formation and dissociation conditions.

III. The same procedure was repeated for three types of salt NaCl, KBr and NaF with different concentrations and two different initial pressures

which ranging between (0.39 to 0.3)MPa, to obtain the formation condition, as illustrated in Table 1.

After completion each test run, the obtained data from the three steps above were plotted to find the conditions (pressure and temperature) that were used in calculating the thermodynamic conditions.

Table 1: The operating data of the clathrate system

Salt type	Concentration (mg/L)	P (MPa)	T (K)	Salt type	Concentration (mg/L)	P (MPa)	T (K)
No salt	0	0.42	284		5000	0.3	281.6
No salt	0	0.3	282.2	KBr	10000	0.38	282
No salt	0	0.25	279.7		10000	0.3	280.8
No salt	0	0.2	279.2	KBr	15000	0.36	280.7
NaCl	5000	0.4	283		15000	0.3	280.2
	5000	0.3	281	NaF	5000	0.38	282.9
NaCl	10000	0.38	281.8		5000	0.3	281.8
	10000	0.3	280	NaF	10000	0.38	282
NaCl	15000	0.36	281		10000	0.3	281
	15000	0.3	279.6	NaF	15000	0.36	281
KBr	5000	0.39	282.5		15000	0.3	280.6

3. Mathematical Model

A kinetics model of hydrate formation system was investigated. In addition, the compressibility factor was calculated by the thermodynamic equation that focused on the conditions of the systems. The following assumptions for Kinetic model concerning the presence of the hydrate former molecules in the hydrate cavities [19] are:

a. The phenomena of nucleation and growth of hydrate accurse at the gas-liquid boundary in the liquid layer.

b. Hydrate cavities are spherical .

c. Each cavity can engage a maximum of one guest molecule .

d. The interactions between guest-guest molecules are negligible .

e. The structural properties of the water lattice are not deformed by guest molecules .

I. Amount of gas consumed (Δn)

The equation of water and R134a gas to form hydrate can be expressed through the following equation [20]:



M= The hydrate number (number of water molecules)

$$M = \frac{136}{8\theta_L + 16\theta_S} \quad (2)$$

θ_L, θ_S = The fraction of linked large and small cavities occupied by guest molecules, respectively.

$$\theta_L = \frac{C_L f_G}{1 + C_L f_G} \quad (3)$$

$$\theta_S = \frac{C_S f_G}{1 + C_S f_G} \quad (4)$$

C_L, C_S is the Langmuir constant for large cavities and small cavities for R134a hydrate which calculated as:

$$C_L = \frac{A_L}{T} \exp \left[\frac{B_L}{T} \right] \quad (5)$$

$$C_S = \frac{A_S}{T} \exp \left[\frac{B_S}{T} \right] \quad (6)$$

Where f_G is the fugacity of (R134a) gas. To calculate f_G , equation (7) may apply.

$$f_G = \phi * P \quad (7)$$

Where, ϕ is fugacity coefficient, equation (8) can be used to estimate ϕ through Peng-Robinson equation [21].

$$\ln \phi = (z-1) - \ln(z-B) - \frac{A}{2\sqrt{2}B} \ln \left(\frac{z+(1+\sqrt{2})B}{z+(1-\sqrt{2})B} \right) \quad (8)$$

Calculations of compressibility factors for equation (8) are found through in the following equations (9- 29), in which A and B are adjustable parameters for R134a gas. The calculations of process design, cubic equations of state are mostly used. The pressure, temperature, molar volume and gas constant are related in the equations below [14]:

Peng and Robinson are the most popular of cubic equations given by:

$$P = \frac{RT}{V-b} - \frac{a}{V^2 - 2bV - b^2} \quad (9)$$

$$Z = \frac{V}{V-b} - \frac{RT(V^2 + 2bV - b^2)}{P V} \quad (10)$$

$$\text{Where, } Z = \frac{P V}{RT} \quad (11)$$

$$T_r = \frac{T}{T_c} \quad (12)$$

$$P_r = \frac{P}{P_c} \quad (13)$$

$$a = 0.45724 \left(\frac{R^2 T_c^2}{P_c} \right) \alpha \quad (14)$$

$$\alpha = (1 + k (1 - T_r))^2 \quad (15)$$

$$k = 0.37464 + 1.54226 \omega - 0.26992 \omega^2 \quad (16)$$

$$b = 0.077796 \left(\frac{R T_c}{P_c} \right) \quad (17)$$

Equation (3) is rearranged to give:

$$Z_3 + \beta Z_2 + \gamma Z + \delta = 0 \quad (18)$$

$$\beta = B - 1 \quad (19)$$

$$\gamma = A - 3B^2 - 2B \quad (20)$$

$$\delta = B^3 + B^2 - AB \quad (21)$$

$$A = \frac{a P}{R^2 P^2} \quad (22)$$

$$B = \frac{b P}{R T} \quad (23)$$

The following two values are first calculated:

$$q = \frac{\beta^2 - 3\gamma}{2\beta^3 - 9\beta\gamma + 27\delta} \quad (24)$$

$$r = \frac{2\beta^3 - 9\beta\gamma + 27\delta}{54} \quad (25)$$

$$\theta = \arccos \left(\frac{r}{q^2} \right) \quad (26)$$

Then, the three roots are given by:

$$Z_1 = -2q^{1/2} \cos \left(\frac{\theta}{3} \right) - \left(\frac{\beta}{3} \right) \quad (27)$$

$$Z_2 = -2q^{1/2} \cos \left(\frac{\theta + 2\pi}{3} \right) - \left(\frac{\beta}{3} \right) \quad (28)$$

$$Z_3 = -2q^{1/2} \cos \left(\frac{\theta + 4\pi}{3} \right) - \left(\frac{\beta}{3} \right) \quad (29)$$

The largest Z value identifies the compressibility factor of vapor [22].

The moles of the hydrate former consumed throughout the formation of hydrate are obtained by applying the real gas law as follows [21].

$$\Delta n = \frac{P_0 V_0}{z_0 R T_0} - \frac{P_t V_t}{z_t R T_t} \quad (30)$$

Where, P and T represent the pressure and temperature of the cell correspondingly, and z defines the compressibility factor. The “0” subscripts refer to the initial conditions, while “t” refers to the conditions at the time, t, of the system. To estimate volume of un reacted R134a gas inside a cell, the next equation is used:

$$V_t = V_{\text{cell}} - V_{w0} + V_{RWt} - V_{Ht} \quad (31)$$

$$V_{RWt} = M \times \Delta n \times v_W^L \quad (32)$$

Where v_W^L displays the molar volume of water that may be calculated by the following relation [Hashemi H. et al.; 2015b:

$$V_{Ht} = M \times \Delta n \times v_W^{MT} \quad \dots \quad (33)$$

Where the v_W^{MT} is the volume occupied by empty hydrate lattice which is determined by the below expression [23]:

$$v_W^{MT} = (17.13 + 2.249 \times 10^{-5} T + 2.013 \times 10^{-2} \frac{10^{-30} N_A}{136} - 8.006 \times 10^{-9} P + 5.448 \times 10^{-12} P^2) \quad (34)$$

II. The growth rate of hydrate formation:

The rate of growth can be presented using the below equation [24]:

$$r(t) = - \frac{dn_R}{dt} \Big|_{t_i} = \frac{\Delta n_R}{\Delta t} \Big|_{t_i} = \frac{(n_{R,i-1} - n_{R,i+1})}{(t_{i+1} - t_{i-1}) * n_{W0}} \quad (35)$$

$n_{R,i-1}$ and $n_{R,i+1}$ present the moles of R134a gas which is hydrate former at t_{i-1} and t_{i+1} , respectively. n_{W0} is the initial number of moles of water.

III. Water to hydrate conversion

The conversion of water to hydrate which is defined as the moles of water converted to hydrate for each mole of water feed and can be estimated by relation below [25]:

$$\text{The water conversion} = \frac{M * \Delta n}{n_{W0}} * 100 \quad (36)$$

The amount of consumed gas, hydrate growth and rate constant calculation were programmed using

MATLAB. The plan of the previous calculation is presented in Figure 6. Dissociation condition The Z model calculation was programmed using MATLAB. The diagram of the previous calculation is presented in Figure 7.

4. Results and Discussion

The results of kinetic models of hydrate formation for binary and ternary systems were included for different salt types; sodium chloride (NaCl), potassium bromid (KBr) and sodium florid (NaF).

I. Gas hydrate formation visual observations

Hydrate formation was visually observed through the cell side as Figure 8 that shows photographic pictures through the formation stage. The experiments were done by isochoric pressure method, as the cell was loaded with R134a gas pressurized to the desired pressure (as an experiment set up), the cell solution temperature is decreased slowly. Some clouds were appeared at

the top of the solution, as shown in Figure (8-a). After a while, foam like view apparently seen in the cell was recognized, it was a significant sign for hydrate nucleation, see Figure (8-b). The hydrate layer could be noticed inFigure (8-c), this layer thickness increased with time as a result of the hydrate formation growth. In Figure (8-d), the pressure inside the cell decreased with the time, then the hydrate layer thickness remained constant, as shown in Figures (8-e) and (8-f).

II. Kinetic results

The suggested model was used for the results of the experimental study of hydrate formation for binary system and for ternary system to obtain the gas consumed, formation rate and other parameters of gas hydrate for binary and ternary systems.

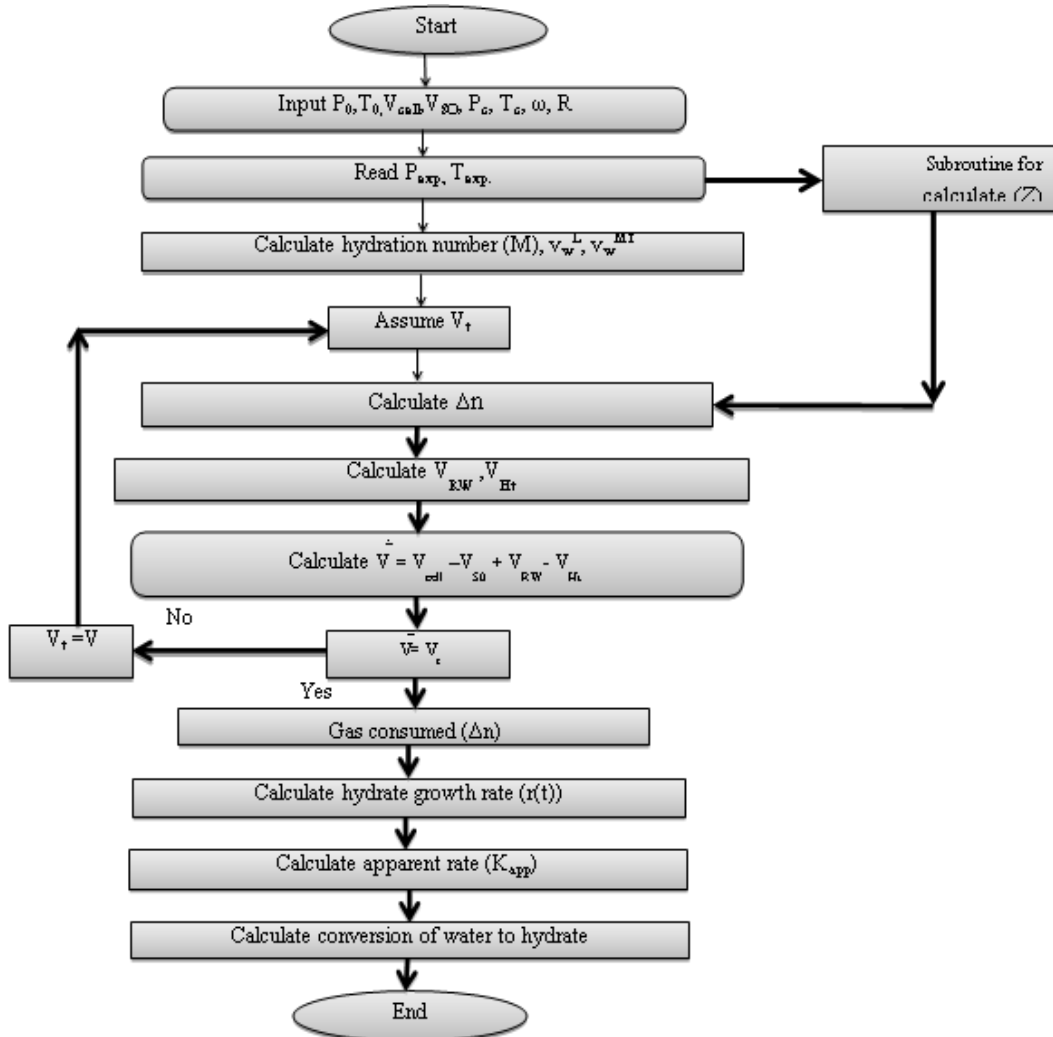

Figure 6: The suggested algorithm to calculate the gas consumed and the apparent rate hydrate formation of R134a.

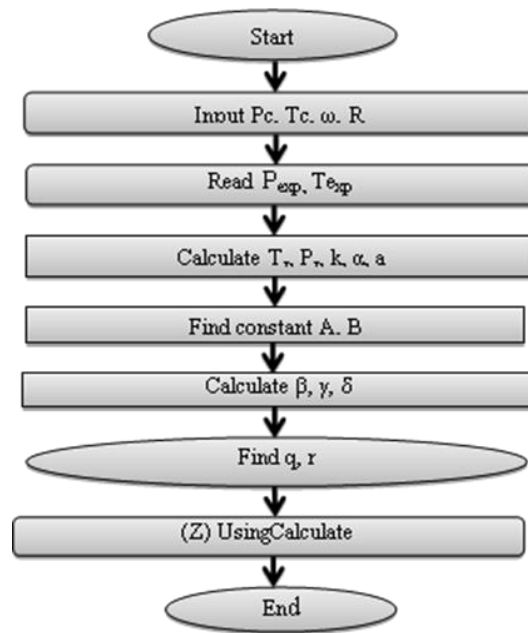

Figure 7: Subroutine to calculate the compressibility factor (Z) by Peng and Robinson

Gas consumption

The pressure drop in the cell was represented by the numbers of R134a molecules leaving the gas phase, which entering in the cages of hydrate at liquid phase. The gas consumption was calculated at various initial pressures through the gas hydrate formation for a binary system, as shown in Figures 9, 10, 11 and 12. From these figures, the starting time of gas consumed (hydrate formation) is considered as a time zero in the graphs. The initial gas pressure effects on the gas consumed during the hydrate formation were noticed clearly. As presented in Figure 12, it may be seen as a step

reduction in pressure in the cell, that is due to temperature decrease inside the cell. After a certain time, the pressure dropped sharply because of the rapid formation of the clathrate and increasing of R134a molecules leaving the gas phase and entering in the hydrate cages. That is also can be recognized by the gas consumption curve. The two curves seem symmetrical as the refrigerant gases consumed by mass transfer reflect the effects on the pressure drop.

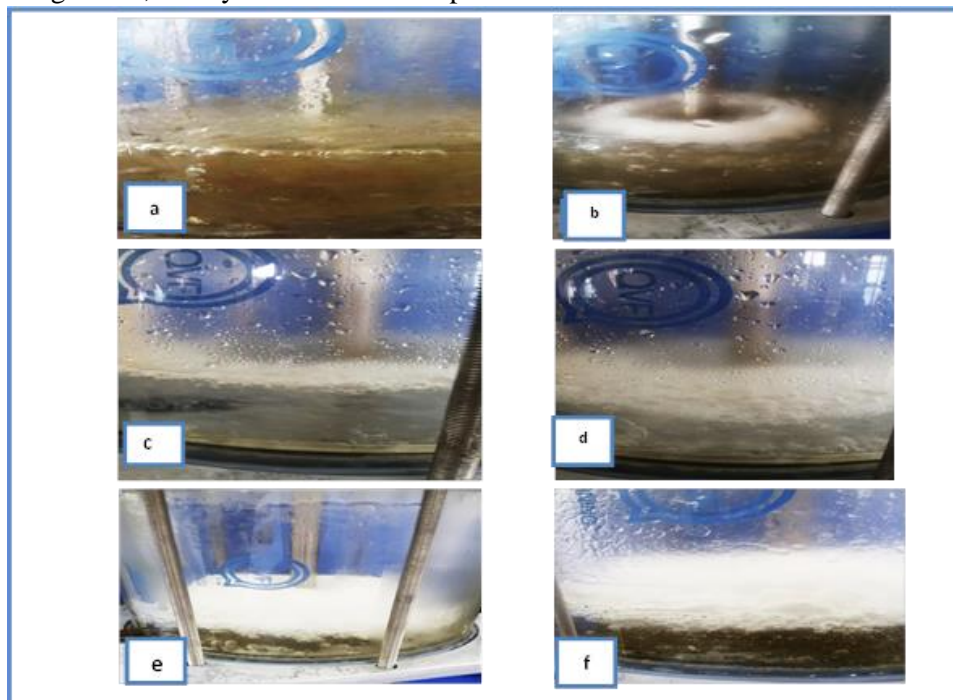

Figure 8: (a-b-c-d-e-f): Typical sequence for R134a clathrate hydrate formation

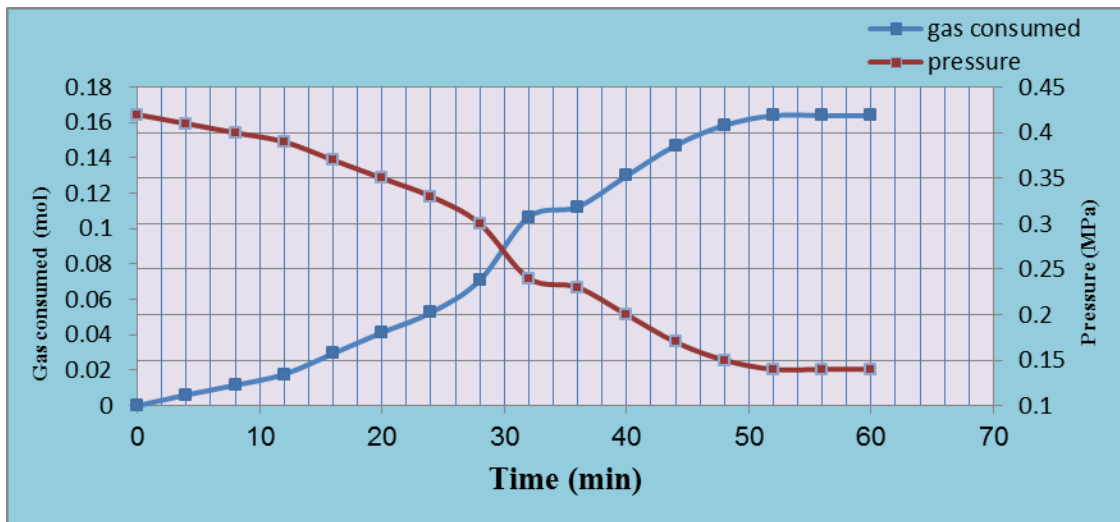

Figure 9: The graph of R134a gas consumed versus time at initial pressure of 0.42 MPa during the hydrate formation process.

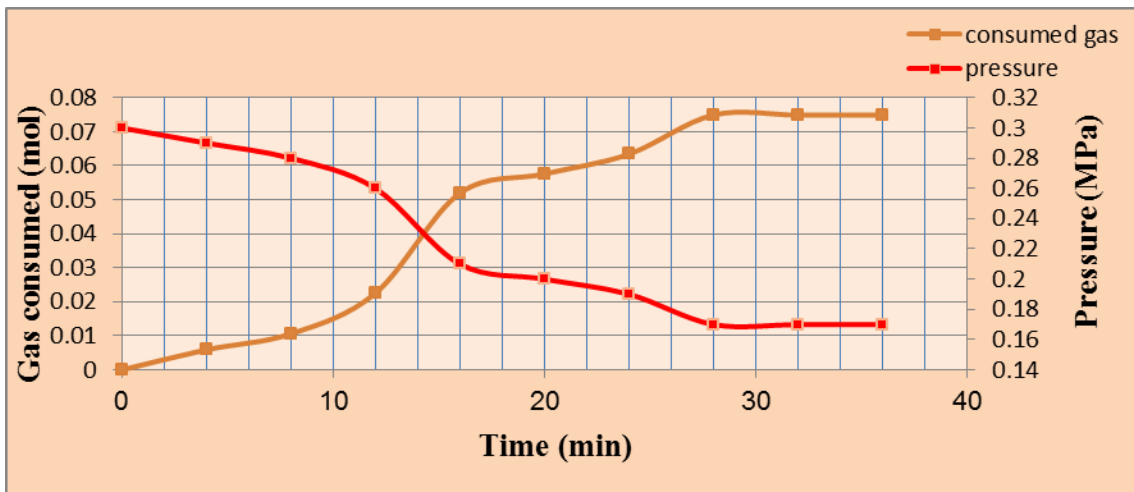

Figure 10: The graph of R134a gas consumed versus time at initial pressure 0.3 MPa during the hydrate formation process.

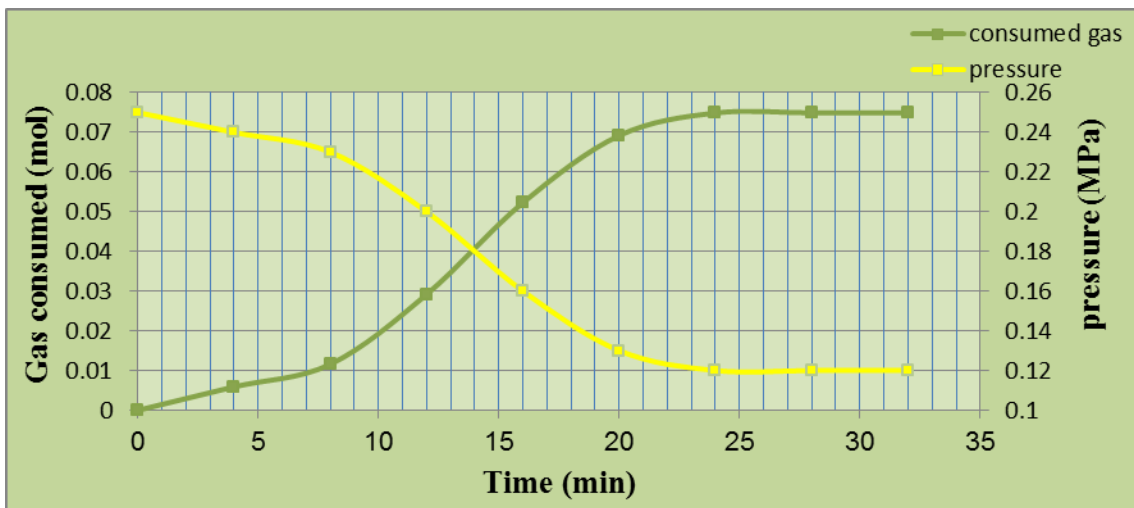

Figure 11: The graph for R134a gas consumed versus time at initial pressure of 0.25 MPa during the hydrate formation process.

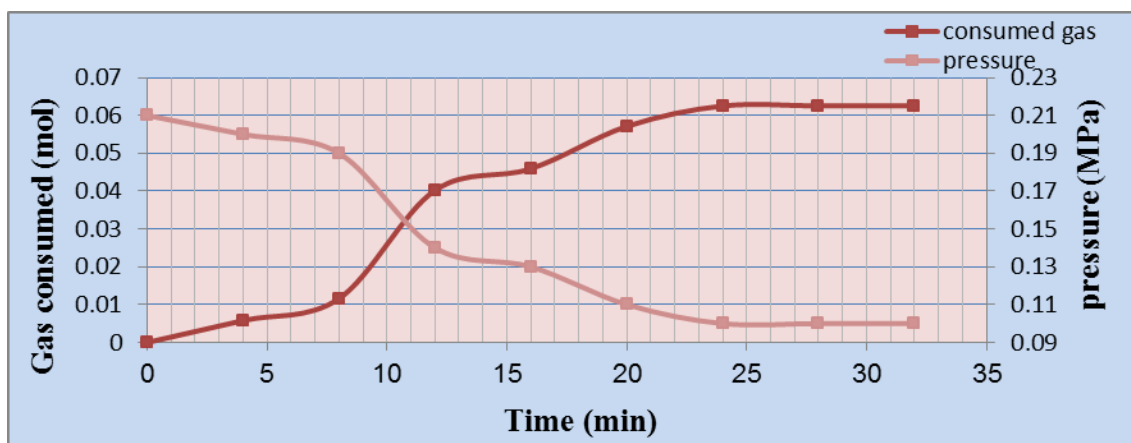

Figure 12: The graph of R134a gas consumed versus time at initial pressure of 0.21 MPa during the hydrate formation process.

In the cell of the isochoric system, the gas consumption of the binary system is plotted on the same graph, as shown in Figure 13. As shown in the plot, with the increase in initial pressure, the consumed gas raised with time. This result indicates that there is a higher driving force represented by the difference in the fugacity of the

gas phase for the formation of gas hydrate when the initial pressure is increased. The results of these experiments support those obtained by Raz [26] which show that the gas hydrate forms faster at higher pressures.

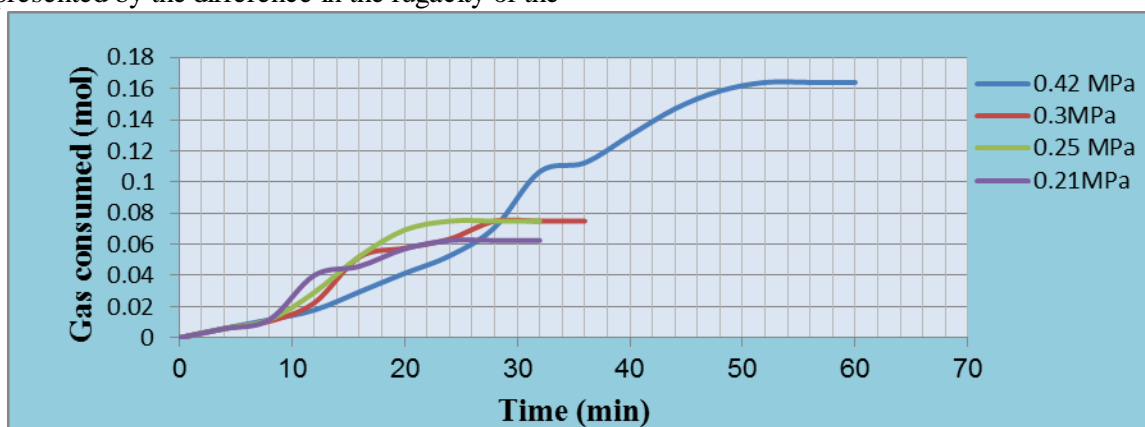

Figure 13: The plots of consumed moles of R134a gas during the formation of gas hydrate versus time under different initial pressure conditions.

The different gas consumptions in the experiments at initial pressure 0.42 MPa for binary and ternary systems are shown in Figure 14, it depicts that when the salt concentration increases, the gas consumption decreases and that is because the salt concentration effects on the number of water cages reduced due to the effects of salt ion in the solution. The same behavior was noticed by the

other salts types used in the experiments also at initial pressure 0.42MPa for binary and ternary systems as shown in the Figures 15 and 16. In these figures, the gas consumed increases slowly at the initial time, and the moles of gas consumed increase with increase drop in the pressure and temperature inside the cell due to the nucleation and growth of hydrate layer.

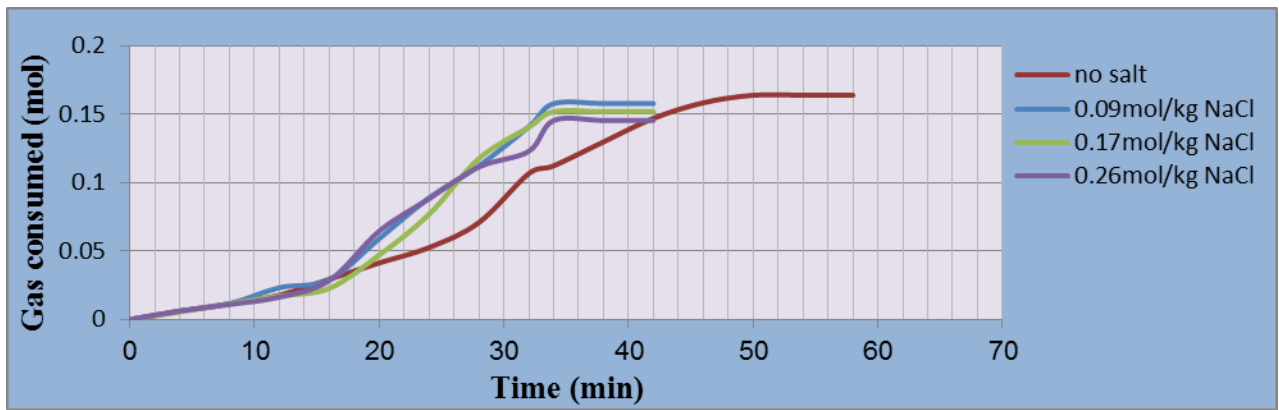

Figure 14: The gas consumed of hydrate formation for a ternary system with NaCl salt for three concentrations at initial pressure 0.42MPa.

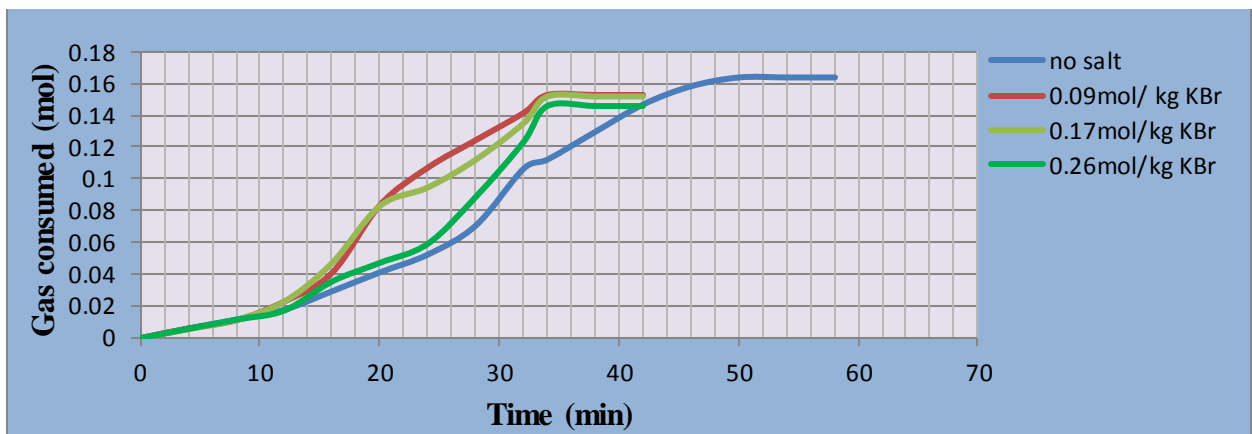

Figure 15: The gas consumed of hydrate formation for ternary systems for KBr electrolyte for three concentrations at initial pressure 0.42MPa.

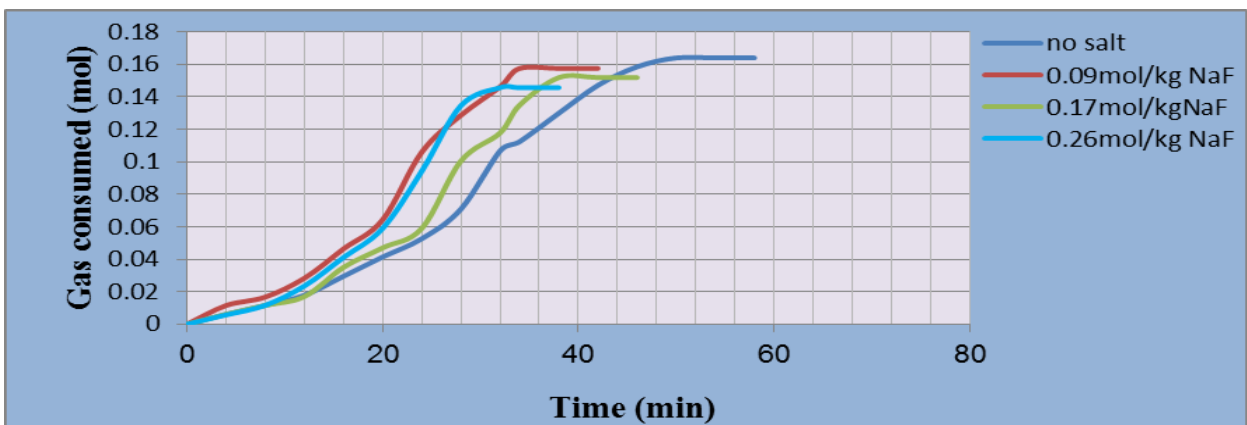

Figure 16: The gas consumed of hydrate formation for ternary systems for NaF salts for three concentrations at an initial pressure of 0.42 MPa.

Growth rate of R134a hydrate formation

The rate of hydrate is mostly expressed as the molecules of R134a converted to hydrate. In this work, the growth rates are described with the time for the binary and ternary system. In Figures 17 and 18, the difference in the rate of growth during the growth period depends on the initial pressure

and the degree of sub cooling of hydrate formation. The rates of growth reduce when time increases, because of the dropping in the driving force with time. The hydrate growth increases with increase initial pressure, as shown in Figures 19 and 20. These figures show that at 0.42MPa, the highest rate and the lowest were at 0.21 MPa.

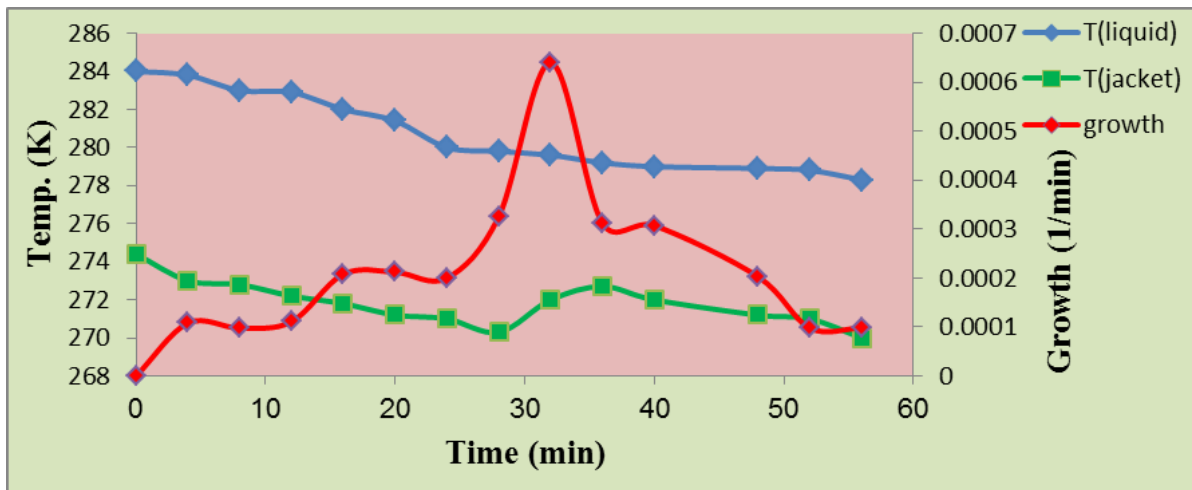

Figure 17: The R134a hydrate growth rate against time at initial pressure of 0.42 MPa.

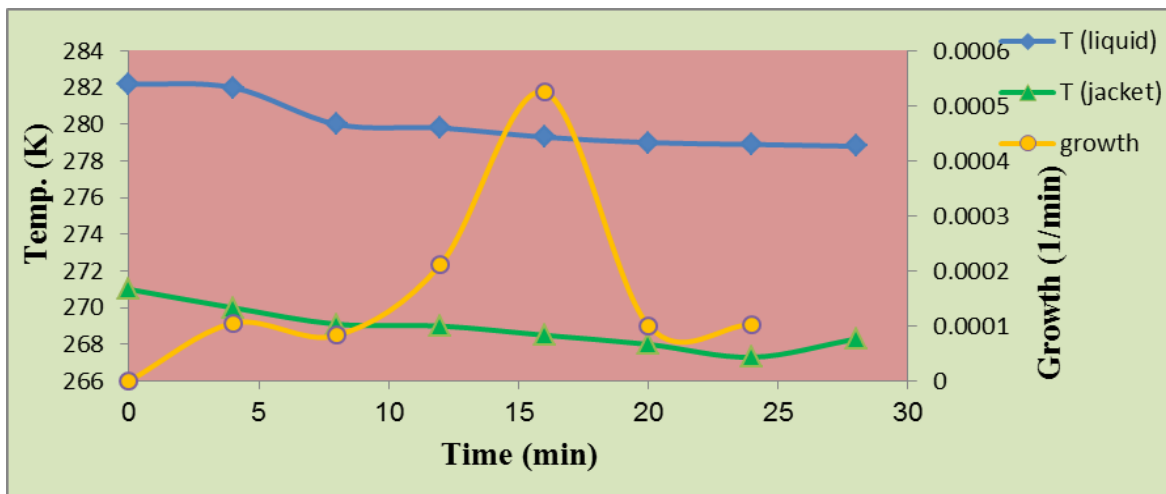

Figure 18: The R134a hydrate growth rate against time at initial pressure 0.3MPa.

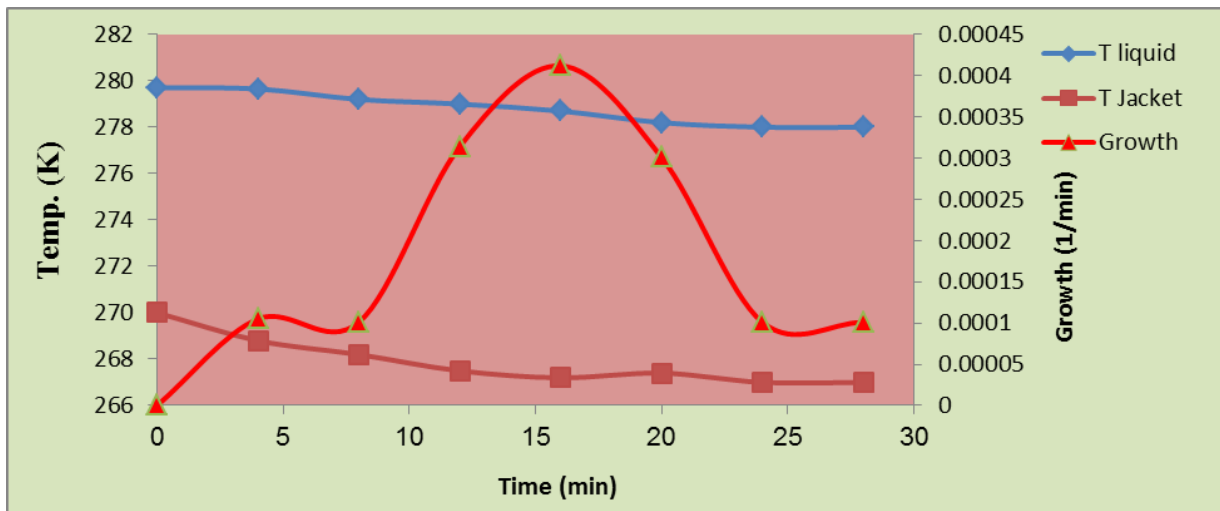

Figure 19: The R134a hydrate growth rate against time at initial pressure of 0.25 MPa.

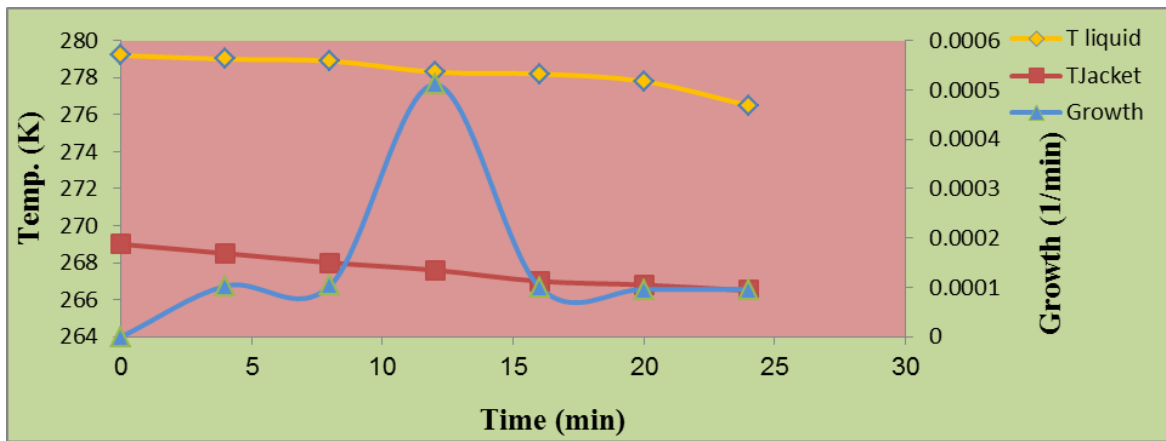

Figure 20: The R134a hydrate growth rate against time at an initial pressure of 0.21 MPa.

For the ternary system, the hydrate growth represented in Figure 21 for three electrolytes at high concentration. The different salts have different influence on the growth of hydrate. Add salts reduced the final amount of hydrate also increased the rate of hydrate formation and finally decrease the time to reach the steady state. The

growth rate in the presence of NaCl for ternary system increases gradually until reaching the maximum value at 20 minute where the maximum rate value in the presence of KBr and NaF reaches at the same time of 28 minute.

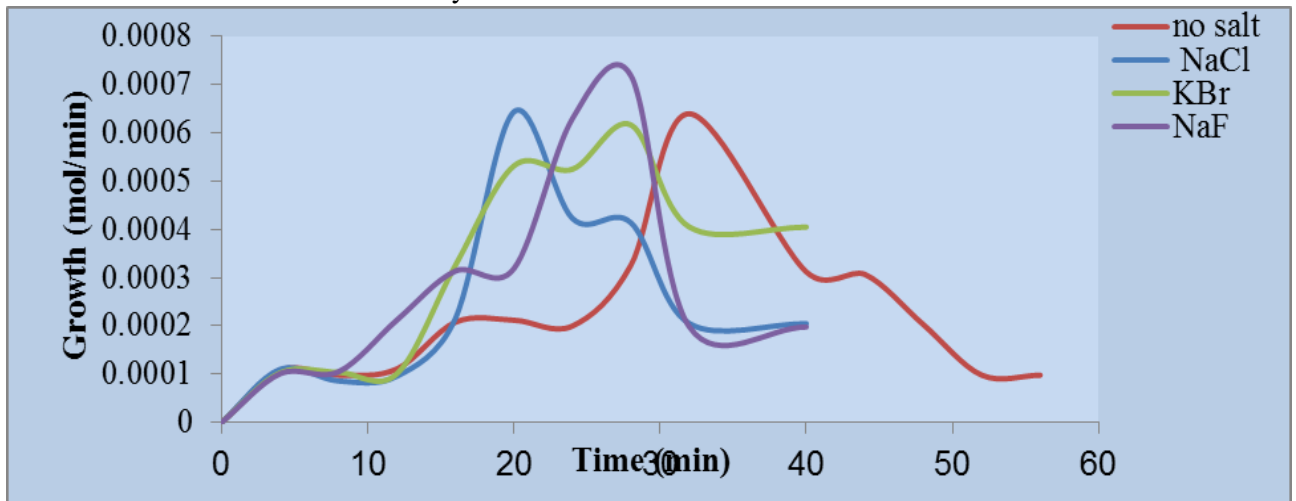

Figure 21: The R134a hydrate growth rate for a ternary system of three types of salt At 0.26 mole/kg against time at initial pressure 0.3 MPa.

Water to hydrate conversion

The moles of water transforms to hydrate during the hydrate growth process were calculated for binary system and ternary system. For a binary system, the water conversion to hydrate was represented at different initial pressures as shown in Figure 22. It was found that with the increase the initial pressure, the water conversion increases due to increase the driving force with the time.

For the ternary system, the water to hydrate conversion was represented as function with time for NaCl, KBr and NaF at three concentrations for each type of salt. For three types of salt, the water to hydrate conversion increase with decrease in the concentration of salts, as shown in Figures 23, 24 and 25. The decrease in the water conversion is due to that the addition of salts to the solutions reduces the hydrate formation.

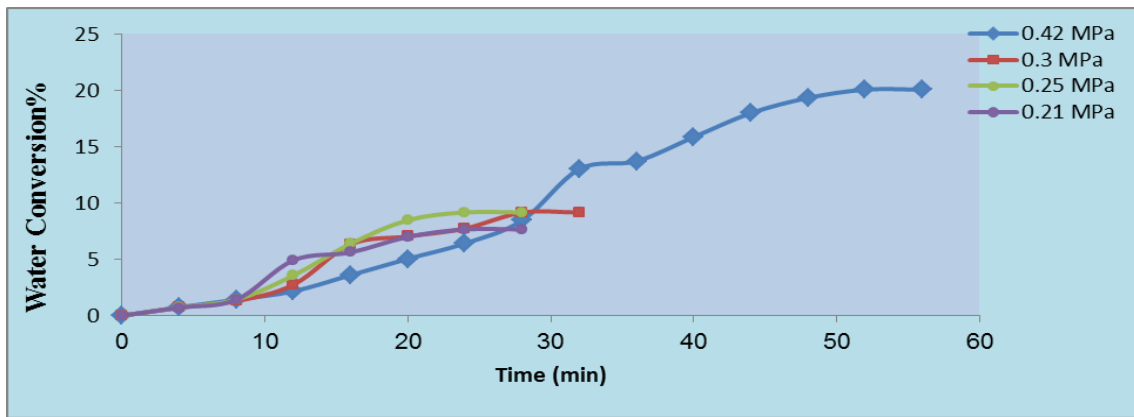

Figure 22: The water to hydrate conversion as function with time for the binary system at different initial pressures.

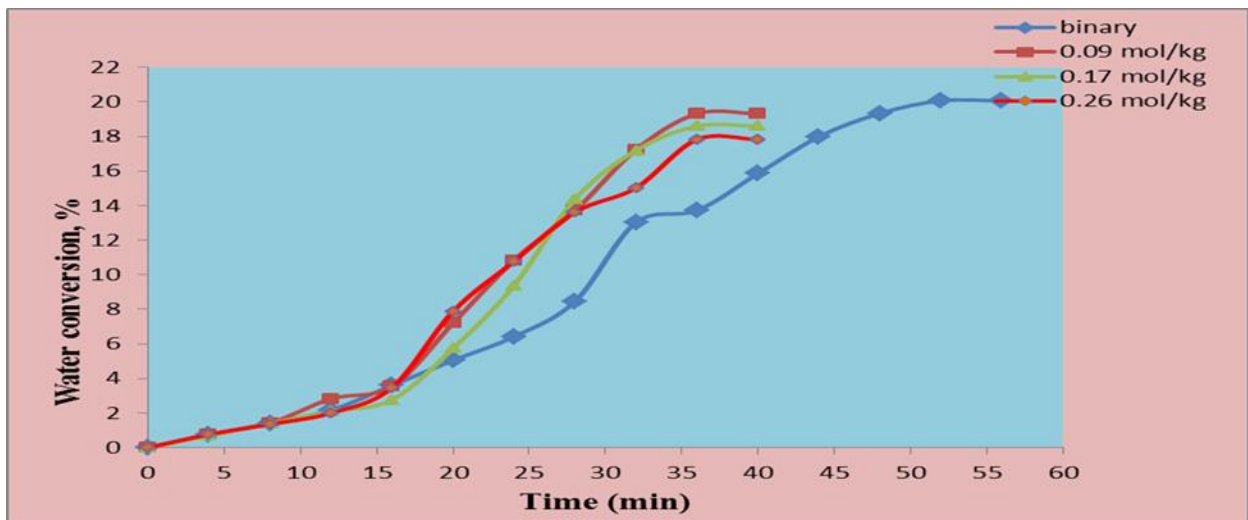

Figure 23: The water to hydrate conversion as function with time for the ternary system in the presence of sodium chloride.

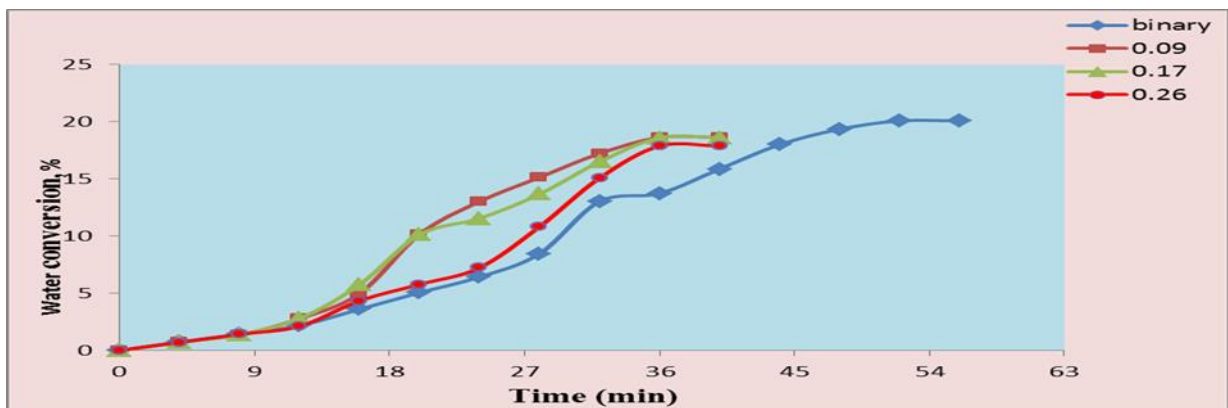

Figure 24: The water to hydrate conversion as function with time for the ternary system in the presence of potassium bromide at three concentrations.

The comparison between water conversions of three salts at 0.26 mol /kg and the binary system is represented in Figure 26. The ternary system in the

presence of NaCl, KBr and NaF had the same conversion of water to hydrate, which was lower than the conversion of a binary system.

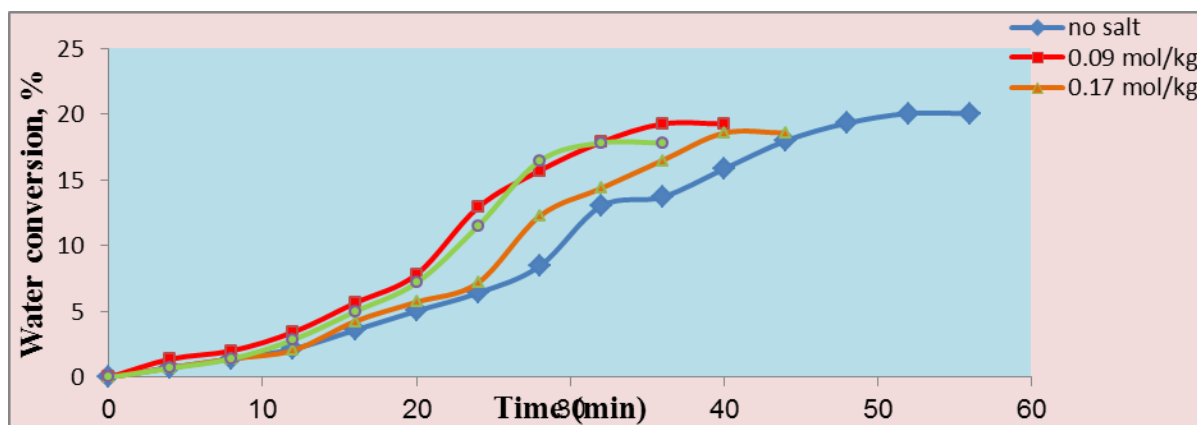

Figure 25: The water to hydrate conversion as function with time for the ternary system in the presence of sodium fluoride at three concentrations.

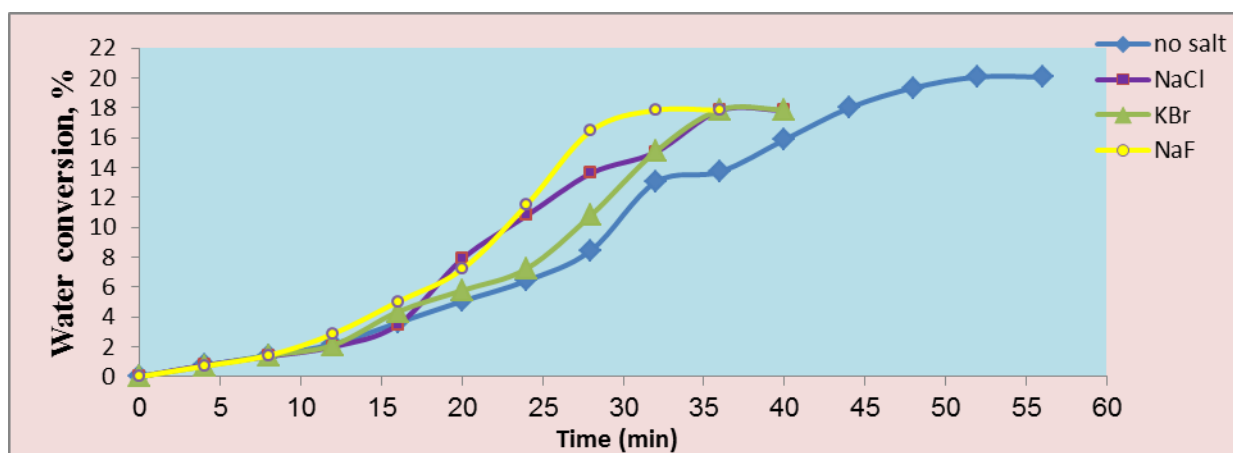

Figure 26: the water to hydrate conversion as function with time for the ternary system in the presence of different salts at 0.26 mol/kg.

5. Conclusions

1. R134a refrigerant gas was used in the current work to form hydrate in a binary system (water+ R134a) and ternary system (water +R134a+ salt). Three types of salt were used in this study (NaCl, KBr and NaF) with different concentrations.
2. The effects of the initial pressure on the gas consumed, rate of growth and water to hydrate conversion were studied by the kinetic of hydrate formation.
3. The results showed that when the initial pressure increase from 0.21 MPa to 0.42 MPa, the rate of hydrate formation or the moles of R134 consumed were increased by (0.1015) mols due to the increased driving force of hydrate formation. Also, other functions, such as the growth rate and the water conversion increased with increasing initial pressure.
4. The hydrate formation kinetic studies were done for ternary systems, it was noticed that the existence of the salt in the hydrate formation system decreases the gas consumed about (0.0184) mol, whereas water to hydrate conversion, the growth rate and apparent rate constant are slightly decreased.

References

- [1] J. Carroll, "Natural Gas Hydrates," Third Edition, Calgary, Canada, pp.1-21, 2014.
- [2] A. Smith, "Phase equilibria of refrigerant gas hydrate systems in the presence of sucrose," M.Sc. Thesis, University of KwaZulu-Natal, Iran, 2015.
- [3] M. Karamoddin and F. Varaminian, "Study on the growth process of HCFC141b hydrate in the isobaric system by a macroscopic kinetic model," International Journal of Refrigeration, 44, pp.1-25, B, 2014.
- [4] M. Abolala., M. Karamoddin and F. Varaminian, "Thermodynamic modeling of phase equilibrium for gas hydrate in single and mixed refrigerants by using SPC-SAFT equation of state," Fluid Phase Equilibrium, 370, pp. 69–74, 2014.
- [5] P.B. Kerkar, K. Horvat, D. Mahajan and K.W. Jones, "Formation and Dissociation of Methane Hydrates from Seawater in Consolidated Sand: Mimicking Methane Hydrate Dynamics beneath the Seafloor," Energies, 6, pp.6225-6241, 2013.
- [6] P. Thokozani Ngema, P. Naidoo and A. Mohammadi, "Thermodynamic stability conditions of clathrate hydrates for refrigerant (R134a or R410a or R507) with MgCl₂ aqueous solution," Fluid Phase Equilibria, pp. 1-7, 2014.
- [7] P.T. Ngema, P. Naidoo, D. Richon, A.H. Mohammadi and D. Ramjugemath, "Experimental Clathrate Hydrate

- Dissociation Data for Systems Comprising Refrigerant+ CaCl₂ Aqueous Solutions,” J. Chem. Eng. Data, 61:pp. 827–836, 2016.
- [8] M. Karamoddin and F. Varaminian, “Solubility of R22, R23, R32, R134a, R152a, R125 and R744 Refrigerants in Water by Using Equations of State,” International Journal of Refrigeration, 24, pp.1-24, 2012.
- [9] A.A. Chernov, A.A. Pil’nik, D.S. Elistratov, I.V. Mezentsev, A.V. Meleshkin, M.V. Bartashevich and M.G. Vlasenko, “New hydrate formation methods in a liquid-gas medium,” Kutateladze Institute of Thermo physics, 7, pp.1-9, 2017.
- [10] J. S. Zhang, S. Lee and J. Lee, “Kinetics of Methane Hydrate Formation from SDS Solution,” Ind. Eng. Chem. Res., 46, pp.6353-6359, 2007.
- [11] K.N. Park, S.N.Y. Hong, J.W. Lee, K.C. Kang, Y.C. Lee, H.A. M.-G. and J.D. Lee, “A new apparatus for seawater desalination by gas hydrate process and removal characteristics of dissolved minerals (Na⁺, Mg²⁺, Ca²⁺, K⁺, B³⁺),” Desalination, 274, pp. 91-96, 2011.
- [12] M. Max, “Natural gas hydrate: in oceanic and permafrost environments,” Kluwer Academic Pub, 2003.
- [13] P.T. Ngema, C. Petticrew, P. Naidoo, A.H. Mohammadi and D. Ramjugernath, “Experimental measurements and thermodynamic modeling of the dissociation conditions of clathrate hydrates for (refrigerant + NaCl + water) systems,” J. Chem. Eng. Data, 58, pp.2695–2695, 2014.
- [14] C. Petticrew, “An investigation into the use of fluorinated hydrating agents of industrial waste water,” M.Sc. Thesis, University of Kwa-Zulu Natal, Iran, 2011.
- [15] P. Ilani-Kashkouli, “Thermodynamic Studies on CO₂ Capture through Gas Hydrate Formation Technology,” Ph.D. Thesis, University of KwaZulu-Natal, Iran, 2015.
- [16] R.W. Bradshaw, B.A. Simmons, E.H. Majzoub, W.M. Clift and D.E. Dedrick, “Clathrate Hydrates for Production of Potable Water,” Mater. Res. Soc. Symp. Proc., 930, pp. 1-6, 2006.
- [17] K. Jeong, Y. S. Choo, H.J. Hong, Y.S. Yoon and M.H. Song, “Tetrafluoroethane (R134a) hydrate formation within variable volume reactor accompanied by evaporation and condensation,” Review of Scientific Instruments, 86, pp.1-9, 2015.
- [18] D. Lee, Y. Lee, W. Choi, S. Lee, and Y. Seo, “Accurate measurement of phase equilibria and dissociation enthalpies of HFC-134a hydrates in the presence of NaCl for potential application in desalination,” Korean Journal Chemical Engineering, 33, pp.1425-1430, 2016.
- [19] E.D. Sloan and C. Koh, “Clathrate Hydrates of Natural Gases,” Third Edition, USA, CRC Press Taylor & Francis Group, 2008.
- [20] H. Hashemi, A.H. Mohammadi, S. Babaei, P. Naidoo and D. Ramjugernath, “Experimental study and modeling of the kinetics of refrigerant hydrate formation,” Journal of Chem. Thermodynamics, 82, pp.47–52, 2015.
- [21] J. M. Smith., H.C. Van Ness and M.M. Abbott, “Introduction to Chemical Engineering Thermodynamics,” 6th ed., McGraw Hill, Singapore, 2005.
- [22] R. Smith, “Chemical Process Design and Integration,” University of Manchester, 2005.
- [23] J.B. Klauda, and S.I. Sandler, “a fugacity model for gas hydrate phase equilibria,” Industrial & Engineering Chemistry Research, 39, pp.3377-3386, 2000.
- [24] H. Hashemi, S. Babaei, A. H. Mohammadi and P. Naidoo, “Experimental Measurements and Thermodynamic Modeling of Refrigerant hydrate dissociation condition,” Journal of Chemical Thermodynamic, 80, pp.30-40, 2015.
- [25] S. Babaei, H. Hashemi, A. H. Mohammadi, P. Naidoo and D. Ramjugernath, “Kinetic and Thermodynamic Behavior of CF₄ Clathrate Hydrates,” Journal Chemical of Thermodynamics, pp. 1-38, 2015.
- [26] B. S. Raz, “The Study of Formation and Dissociation of Gas Hydrate,” Petroleum Engineering, M.Sc. Thesis, University of Texas A&M, 2012.