

Radon Gas Concentrations in Soil and Radon Exhalation Rates in Thiqr City

2nd Conference on Environment and Sustainable Development 28-29-Oct-2015

Nada F. Tawfiq

Department of Physics, College of Science, Al-Nahrain University

Hazim L. Mansour 

Department of Physics, College of Education, Al-Mustansiriyah University

Mahmood S. Karim

Department of Physics, College of Education, Al-Mustansiriyah University

Abstract

First part to determination concentrations of Rn-222 in surface samples of soil, the highest average concentration of Rn-222 was found in AL-Refai region was equal to $(127.500 \pm 2 \text{ Bq/m}^3)$, while lowest the average was found in AL-Aeckekh region which was equal to $(33.750 \pm 2.2 \text{ Bq/m}^3)$, with an average value of $(75.875 \pm 21.8 \text{ Bq/m}^3)$, while the (RER) was found to be ranged from $(36.821 \text{ mBq/m}^2\text{h})$ (T_{19} region) to $(139.103 \text{ mBq/m}^2\text{h})$ (T_1 region), with average value $(82.780 \pm 18.6 \text{ mBq/m}^2\text{h})$, second part to determine of concentration of Rn-222 in samples of soil from depth 10 cm, the highest average concentration of radon in AL-Refai region which was equal to $(109.500 \pm 7.7 \text{ Bq/m}^3)$, while the lowest average concentration of Rn-222 gas was found in AL-Aeckekh region equal to $(30.250 \pm 2.9 \text{ Bq/m}^3)$, with an average value $(66.703 \pm 14.8 \text{ Bq/m}^3)$, while (RER) was found to be ranged from $(33.003 \text{ mBq/m}^2\text{h})$ (T_{19} region) to $(119.465 \text{ mBq/m}^2\text{h})$ (T_1 region), with value of average $(72.784 \pm 16.2 \text{ mBq/m}^2\text{h})$. The concentration of Rn-222 in surface soil and at depth (10 cm) were less than the recommended value given (ICRP, 1993).

Keywords: Radon Concentration; Soil; Radon exhalation rate; CR-39 nuclear track detector

تركيز غاز الرادون في التربة ومعدل انبعاث الرادون في مدينة ذي قار

الخلاصة

في هذا البحث تم قياس تركيز الرادون في نماذج تربة سطحية ولعمق (10 سم) لمناطق مختلفة من محافظة ذي قار باستخدام باعث جسيمات الفا المنبعثة من غاز الرادون في كاشف الأثر النووي (CR-39). تضمن الجزء الأول التعرف على تركيز الرادون في نماذج التربة السطحية، وكانت النتائج تشير إلى أن أعلى معدل لتركيز غاز الرادون في التربة في محافظة ذي قار كان في منطقة الرفاعي (T_1) والذي كان $(127.500 \pm 2 \text{ Bq/m}^3)$ بينما أقل معدل لتركيز غاز الرادون كان في منطقة العكيكة (T_{19}) والذي كان $(33.750 \pm 2.2 \text{ Bq/m}^3)$ وبمعدل $(75.875 \pm 21.8 \text{ Bq/m}^3)$ بينما تراوح معدل انبعاث الرادون من $(36.821 \text{ mBq/m}^2\text{h})$ في منطقة T_{19} إلى $(139.103 \text{ mBq/m}^2\text{h})$ في منطقة T_1 وبمعدل $(82.780 \pm 18.6 \text{ mBq/m}^2\text{h})$. الجزء الثاني تضمن إيجاد تركيز غاز الرادون في نماذج التربة لعمق (10 سم) وكانت النتائج تشير إلى أن أعلى معدل لتركيز غاز الرادون في التربة في محافظة ذي قار كان في منطقة الرفاعي والذي كان $(109.500 \pm 7.7 \text{ Bq/m}^3)$ بينما أقل معدل لتركيز

غاز الرادون كان في منطقة العيكة والذي كان ($30.250 \pm 2.9 \text{ Bq/m}^3$) وبمعدل (66.703 ± 14.8) (Bq/m^3). بينما تراوح معدل انبعاث الرادون من ($33.003 \text{ mBq/m}^2\text{h}$) في منطقة (T_{19}) الى ($119.465 \text{ mBq/m}^2\text{h}$) في منطقة (T_1) وبمعدل ($72.784 \pm 16.2 \text{ Bq/m}^2\text{h}$). النتائج الحالية تبين ان تركيز الرادون لنماذج التربة السطحية ولعمق (10 سم) كان اقل من القيمة المسموحة (200 Bq/m^3) والمعطاة من قبل الوكالة الدولية للوقاية من الاشعاع لعام (1993).

الكلمات المرشدة: تركيز الرادون، التربة، معدل انبعاث الرادون، كاشف الأثر النووي (CR-39)

INTRODUCTION

Rn-222 gas is a half-life of about (3.825 d) and falls within the noble group elements and decay of the natural U-238 radioactive series, which starts with U-238 [1]. U-238 is a very more widely distributed element in the earth's crust, it is presented naturally everywhere in rocks, sand and soil in various concentrations from one place to another. [2]. It is character Rn-222 noble gas allows it to spread through the atmosphere. The greatest fraction of natural radiation exposure in humans results from inhalation indoors and works places of the decay products of Rn-222 gas [3].

Experimental Procedure

A- Description of Study Area

Thiqr City heart of Iraqi's marshland areas. Figure (1) and Table (1) shows, the studied different sites in Thiqr city [4].

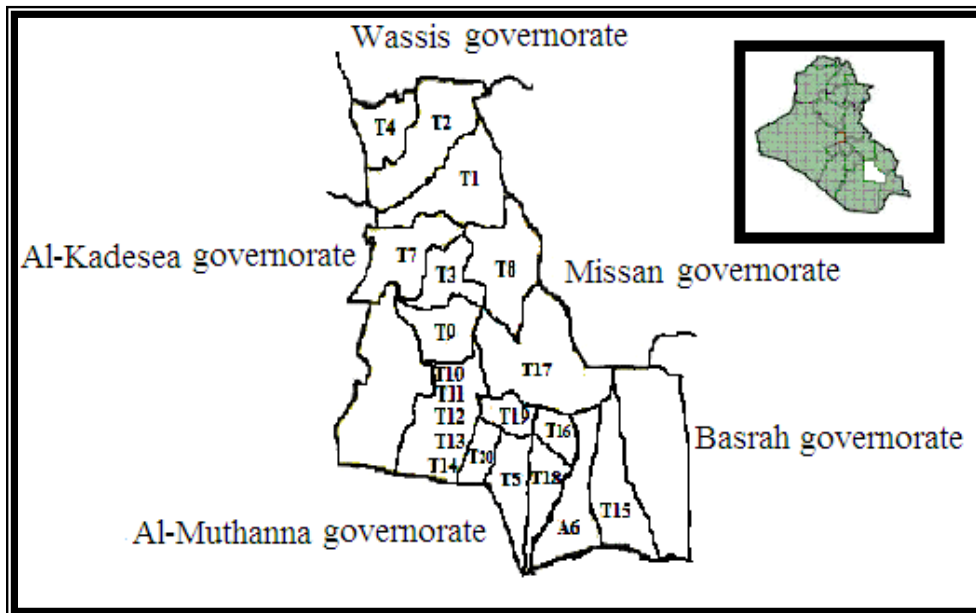

Figure (1). Sketch map shows locations of study samples in Thiqr city

Table (1). Location name and symbol for sites samples in Thiqr city

Symbol	Location name	Symbol	Location name
T ₁	AL-Refai	T ₁₁	AL- Nasiriyah (Sayed Dakhil)
T ₂	Qulat Sikar	T ₁₂	AL- Nasiriyah (Askan)
T ₃	AL-Shatra	T ₁₃	AL- Nasiriyah (AL-Askary)
T ₄	AL-Fajr	T ₁₄	AL- Nasiriyah (Baghdad street)
T ₅	Suq-AL-Shuyukh	T ₁₅	AL- Hammar
T ₆	AL-Fuhud	T ₁₆	AL- Tar
T ₇	AL- Nasir	T ₁₇	AL-Islah
T ₈	AL- Dwaya	T ₁₈	Garmat Beni Saeed
T ₉	AL- Garraf	T ₁₉	AL-Aekeckh
T ₁₀	AL- Nasiriyah (Ur district)	T ₂₀	AL- Fadlia

B- The Detector

Detector plastic of CR-39 of thickness about of (500 μm), area (1×1 cm²). It was used as a detector integrating of α-particles emitted from ²²²Rn [5].

C- The Exposure

The weight of the samples were about of (10 g), the concentration of radon gas in soil was obtained by using cup technique see Figure (2).

Irradiation time after the (30 days), the (CR-39) detectors were etched in (6.25 N) (NaOH) solution at temperature of (60 °C) for (10 h), and the density tracks were recorded using optical microscope and magnification (400x) [6]:

$$\text{Density Tracks } (\rho) = \frac{\text{Average number of total tracks}}{\text{Area of field view}} \tag{1}$$

Standard soil samples, using the relation [7]:

$$C_x = \rho_x \cdot (C_s / \rho_s) \tag{2}$$

Figure (3) shows the relation between concentration of Rn-222 gas and the density of track in standard samples of soil.

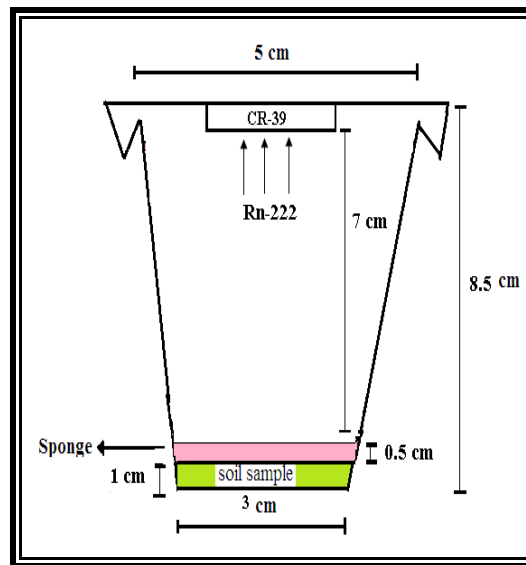

Figure (2). Diagram of cup technique in soil

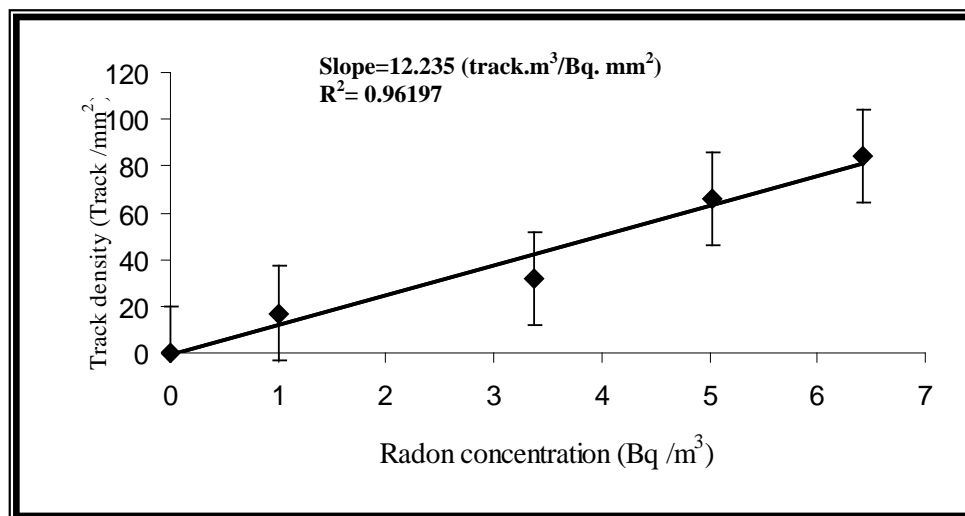

Figure (3). Relation between concentration of Rn-222 gas and density of track in standard soil

D- Calculation of Radon Exhalation Rate

The Rn-222 exhalation rate calculated by using the relation [8]:

$$RER = \frac{CV\lambda}{A [T + \lambda^{-1}(e^{-\lambda T} - 1)]} \quad (3)$$

Results and Discussion

Table (2) presents concentrations of Rn-222 gas in soil for selected regions in Thiqr city. The highest average Rn-222 concentration (obtained by using the relation (2) in surface soil samples was found in T₁ (AL-Refai) region equal to (127.500±2 Bq/m³), while the lowest average concentration of radon was found in T₁₉ (AL-Aekeckh) region which was equal to (33.750±2.2 Bq/m³), with average value (75.875±21.8 Bq/m³), see Figure (4). While the (RER) was found to be ranged from (36.821 mBq/m²h) (T₁₉ region) to (139.103 mBq/m²h) (T₁ region), with an average value of (82.780±18.6 mBq/m²h), see Figure (5).

Table (3) presents the concentration of Rn-222 gas in soil for depth (10 cm) for selected regions in Thiqr city, the highest average concentration of Rn-222 in soil was found in (T₁ region) which was equal to (109.500±7.7 Bq/m³), while the lowest average concentration of Rn-222 gas was found in (T₁₉ region) which was equal to (30.250±2.9 Bq/m³), with average value (66.703±14.8 Bq/m³), see Figure (6). While the (RER) was found to be ranged from (33.003 mBq/m²h) (T₁₉ region) to (119.465 mBq/m²h) (T₁ region), with average value (72.784±16.2 mBq/m²h), see Figure (7).

Table (2). (C_{Rn}), mean of (C_{Rn}) and (RER) for surface soil samples in Thiqr city

Sample location	C_{Rn} ($Bq.m^{-3}$)				Mean of C_{Rn} ($Bq.m^{-3}$)	(RER) (mBq/m^2h)
	1	2	3	4		
T ₁	130	129	127	124	127.500±2.0	139.103
T ₂	104	102	110	99	103.750±3.2	113.191
T ₃	71	68	66	63	67.000±3.3	73.097
T ₄	101	99	90	89	94.750±6.1	103.372
T ₅	69	67	62	62	65.000±3.5	70.915
T ₆	61	59	52	54	56.500±4.2	61.642
T ₇	61	59	59	56	58.750±2.0	64.096
T ₈	62	56	55	51	56.000±4.5	61.096
T ₉	89	86	81	80	84.000±4.2	91.644
T ₁₀	80	77	75	71	75.750±3.7	82.643
T ₁₁	91	87	87	82	86.750±3.6	94.644
T ₁₂	91	90	87	85	88.250±2.7	96.281
T ₁₃	70	68	66	62	66.500±3.4	72.552
T ₁₄	91	90	87	96	91.000±3.7	99.281
T ₁₅	78	72	71	69	72.500±3.8	79.098
T ₁₆	71	70	69	66	69.000±2.1	75.279
T ₁₇	109	102	100	98	102.250±4.7	111.555
T ₁₈	51	49	47	39	46.500±5.2	50.732
T ₁₉	36	35	33	31	33.750±2.2	36.821
T ₂₀	77	72	70	69	72.000±3.5	78.552
Average					75.875±21.8	82.780±18.6

Table (3). (C_{Rn}), mean of (C_{Rn}) and (RER) for soil samples for depth (10 cm) in Thiqar city

Sample location	C_{Rn} ($Bq.m^{-3}$)				Mean of C_{Rn} ($Bq.m^{-3}$)	(RER) (mBq/m^2h)
	1	2	3	4		
T ₁	119	112	106	101	109.500±7.7	119.465
T ₂	94	92	90	84	90.000±4.3	98.190
T ₃	68	64	60	60	63.000±3.8	68.733
T ₄	89	82	82	80	83.250±3.9	90.826
T ₅	59	55	50	50	53.500±4.3	58.369
T ₆	91	87	86	81	86.250±4.1	94.099
T ₇	58	54	50	48	52.500±4.4	57.278
T ₈	50	47	45	44	46.500±2.6	50.732
T ₉	74	74	69	66	70.750±3.9	77.188
T ₁₀	74	71	68	62	68.750±5.1	75.006
T ₁₁	84	81	77	71	78.250±5.6	85.371
T ₁₂	55	50	49	49	50.750±2.8	55.368
T ₁₃	64	60	59	57	60.000±2.0	65.460
T ₁₄	86	82	80	74	80.500±5.0	87.826
T ₁₅	66	64	61	59	62.500±3.1	68.188
T ₁₆	66	64	61	54	61.250±5.2	66.824
T ₁₇	86	82	82	78	82.000±3.2	89.462
T ₁₈	44	40	39	36	39.750±3.3	43.367
T ₁₉	34	31	29	27	30.250±2.9	33.003
T ₂₀	70	66	64	60	65.000±4.1	70.915
Average					66.703±14.8	72.784±16.2

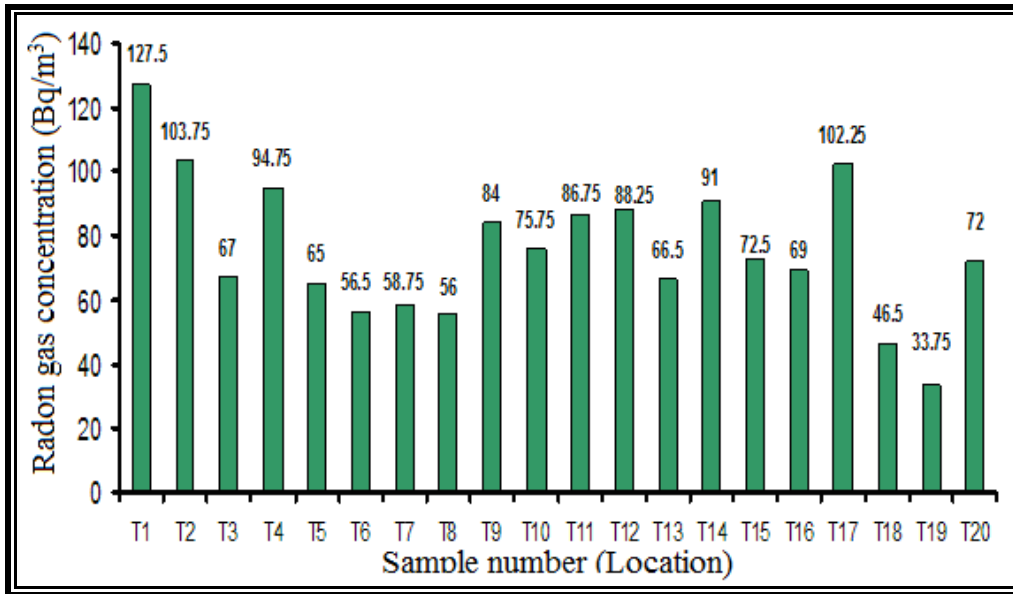

Figure (4). (C_{Rn}) in soil samples in all regions studied in Thiqr city

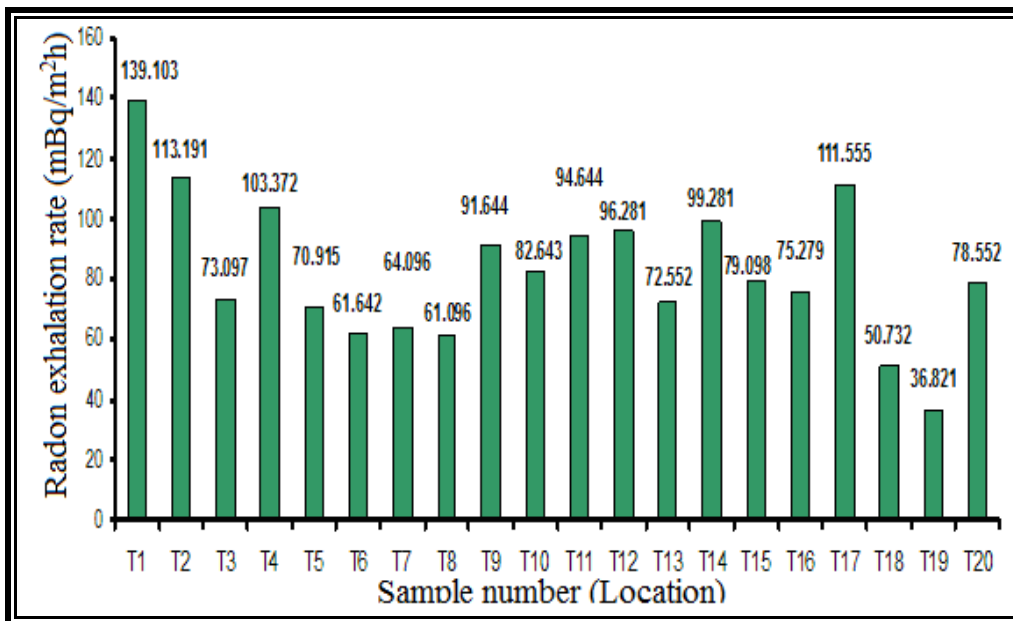

Figure (5). (RER) in soil samples in all regions studied in Thiqr city

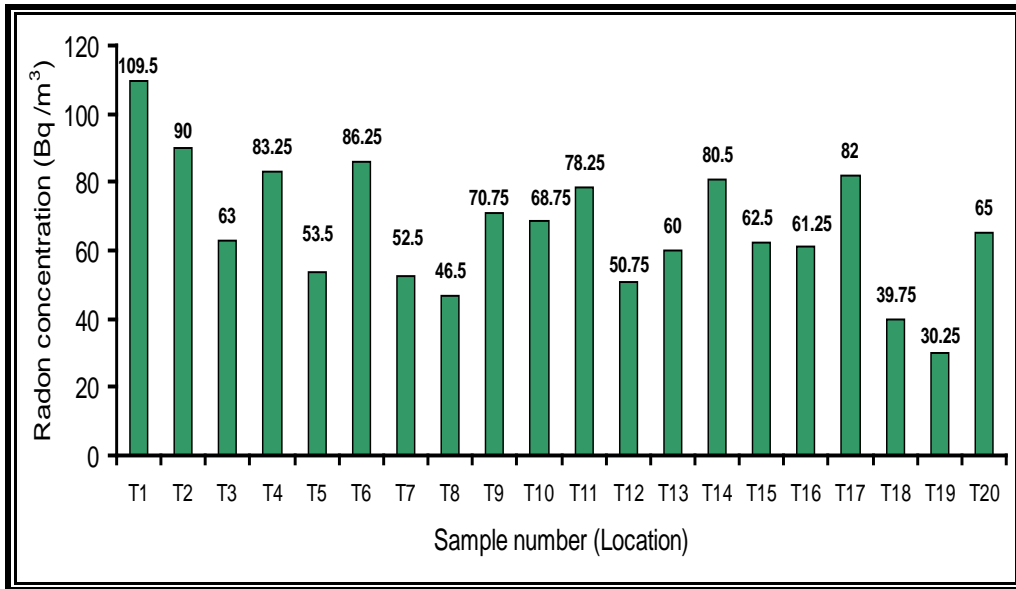

Figure (6) (C_{Rn}) in soil samples for depth (10 cm) in all regions studied in Thiqr city

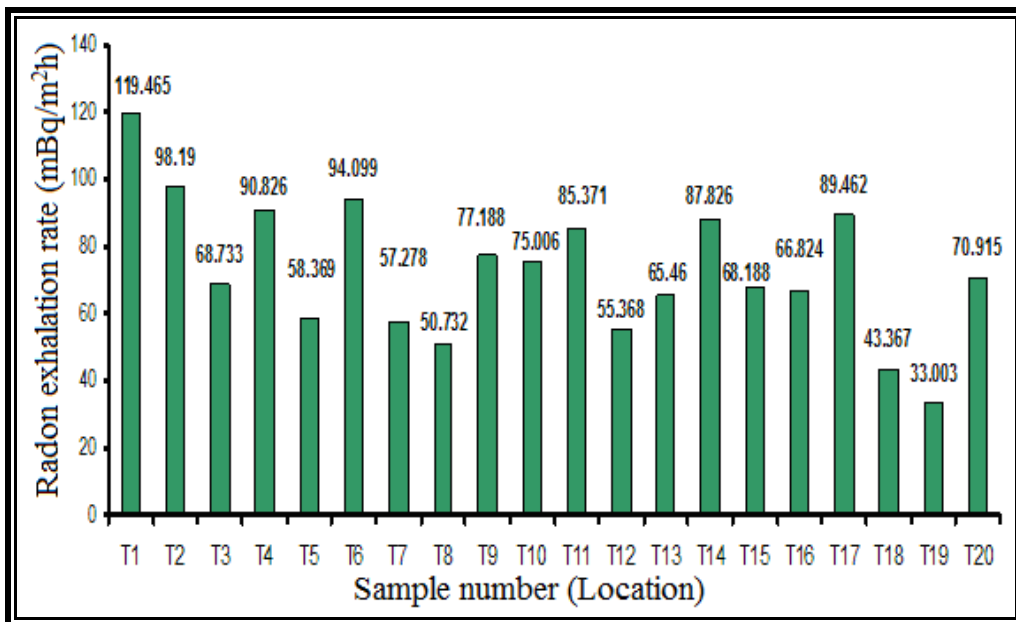

Figure (7). (RER) in soil samples for depth (10 cm) in all regions studied in Thiqr city

Conclusions

Concentrations of Rn-222 gas in the studied soil samples (surface soil and at depth 10 cm) were less than the value of recommended (200 Bq/m³), (ICRP, 1993) [9].

References

- [1] Mansour, H.H., Khdar, S., Abdulla, H.Y., Muhamad, N.Q., Othman, M.M. and Qader, S. "Measurement of indoor radon level in Erbil capital by using solid state nuclear track detector", *Radiat.Measur*, Vol.40, 544-547, 2005.
- [2] Abumurad, K.M. "Chances of lung cancer due to radon exposure in Al-Mazar Al-Shamali, Jordan", *Radiat.Measur*, Vol.34, 537-540, 2001.
- [3] Baixeras, C., Erlandsson, B., Font, Ll. and Jonsson, G. "Radon emanation from soil samples, *Radiat.Measur*", Vol. 34, 441-443, 2001.
- [4] Kadhem Z.G., "concentration of Radioactivity with uranium, radon gas and concentrations of some heavy metals in soil at Al-Nasiriyah city", M.Sc. Thesis, Thiqr University, College of Science for Women, 2012.
- [5] Khan A.J., Varshney A.K., Prasad R, Tyagi R.K., Ramachandran T.V.; "Calibration of a CR-39 plastic track detector for the measurement of radon and its daughters in dwellings", *Nucl Tracks Radiat Meas*, Vol.17, 497-502, 1990.
- [6] Amalds O., Custball N.H. & Nielsen G.A. "Cs¹³⁷ in Montarq Soils", *Health Physics*, Vol. 57, No. 6, 955-958. 1989.
- [7] Durrani S.A. and Bull R.K., "Solid State Nuclear Track Detection: Principles, Methods and Applications", Pergammon Press, U.K., 1987.
- [8] Ferreira A.O., Pecequilo B.R. Aquino and R.R., "Application of a Sealed Can Technique and CR-39 detectors for measuring radon emanation from undamaged granitic ornamental building materials", *Radioprotection Journal*, Vol. 46, No. 6, 49-54, 2011.
- [9] ICRP "International Commission on Radiological Protection against Radon -222 at Home and Work", Publication 65, Pergamum Elsevier, Vol. 35, 1993.