



AALBORG UNIVERSITY
DENMARK

Aalborg Universitet

Adaptive Feature Based Control of Compact Disk Players

Odgaard, Peter Fogh; Stoustrup, Jakob; Vidal, Enrique Sanchez

Published in:

Proceedings of the 44th IEEE Conference on Decision and Control, and European Control Conference ECC'05

DOI (link to publication from Publisher):

[10.1109/CDC.2005.1583165](https://doi.org/10.1109/CDC.2005.1583165)

Publication date:

2005

Document Version

Publisher's PDF, also known as Version of record

[Link to publication from Aalborg University](#)

Citation for published version (APA):

Odgaard, P. F., Stoustrup, J., & Vidal, E. S. (2005). Adaptive Feature Based Control of Compact Disk Players. In Proceedings of the 44th IEEE Conference on Decision and Control, and European Control Conference ECC'05 (pp. 6262-6267). Electrical Engineering/Electronics, Computer, Communications and Information Technology Association. DOI: 10.1109/CDC.2005.1583165

General rights

Copyright and moral rights for the publications made accessible in the public portal are retained by the authors and/or other copyright owners and it is a condition of accessing publications that users recognise and abide by the legal requirements associated with these rights.

- ? Users may download and print one copy of any publication from the public portal for the purpose of private study or research.
- ? You may not further distribute the material or use it for any profit-making activity or commercial gain
- ? You may freely distribute the URL identifying the publication in the public portal ?

Take down policy

If you believe that this document breaches copyright please contact us at vbn@aub.aau.dk providing details, and we will remove access to the work immediately and investigate your claim.

Adaptive Feature Based Control of Compact Disk Players

P.F. Odgaard, J. Stoustrup, P. Andersen & E. Vidal

Abstract—Many have experienced the problem that their Compact Disc players have difficulties playing Compact Discs with surface faults like scratches and fingerprints. The cause of this is due to the two servo control loops which are used to keep the Optical Pick-up Unit focused and radially on the information track of the Compact Disc. The problem is to design servo controllers which are well suited for handling surface faults which disturb the position measurement and still react sufficiently against normal disturbances like mechanical shocks. In previous work of the same authors a feature based control scheme for CD-players playing CDs with surface fault is derived and described. This feature based control scheme uses precomputed base to remove the surface fault influence from the position measurements. In this paper an adaptive version of the feature based control scheme is proposed and described. This adaptive scheme can in contrast with the other scheme adapt to the given fault. The adaptive scheme recomputes the feature extraction bases which is used to remove fault components from the measurements, at each encounter of the given fault. The improvements of this adaptive scheme are illustrated by simulations, with the clear result that the adaptive scheme clearly adapts better to the given faults compared with the non-adaptive version of the feature based control scheme.

I. INTRODUCTION

Optical disc players such as Compact Disc players (CD-players) have become widely used in homes and businesses in the last couple of decades. However, performance issues are still to be improved. One of these issues is the CD-players' problem playing certain discs with surface faults like scratches and fingerprints.

In the CD-player an Optical Pick-up Unit (OPU) is used to retrieve the data/music stored in the spiral shaped information track on the disc. The OPU is positioned by two servo loops. A servo loop is formed to keep the OPU focused on the reflection layer of the disc. The second servo loop keeps the OPU radially tracked.

The OPU includes optics which facilitate measures of the focus and radial distances. The distances are the distance from the actual position of the OPU to the position where the OPU is focused and radially tracked. The main problem with the surface faults is that they introduce additional fault components in the measurements of focus and radial distances. These degenerated position measurements can result in loss of focus and/or tracking.

One possible method to handle these faults is to use a fault tolerant control strategy, where the surface faults are handled in a special way, when detected. Faults are detected

as fast as possible and when a fault is detected, the control strategy is changed in a way that accommodates the detected fault. A frequently used method for detection of faults is to observe changes in either the sum of focus signals or the sum of the radial signals, since a fault would reduce these sums, e.g. see [1]. A simple fault tolerant control strategy has often been used to handle such surface faults. The core idea in this simple approach is not to rely on sensor information during the fault. The sensor signals are simply fixed to zero as long as a fault is detected. This, however, means that the system is operated in open loop, and sometimes this causes loss of tracking.

The research in control of CD-players has been intense in other directions than fault tolerant control, especially in adaptive and robust controllers applied to the CD-player. An interesting example of a μ -controller used in a CD-player was reported in [2], which was based on DK-iterations. An example of an adaptive control design was [3] where a self-tuning controller was suggested. Only [4] addresses the use of FTC in the handling of surface faults such as scratches, fingerprints etc.

In the PhD work by the first author of this paper, see [5], a scheme based on fault tolerant control and signal processing was presented. This scheme is called feature based control, since features are extracted from the detected surface faults and subsequently used to remove the influence from surface faults on the distance signals. The standard nominal controllers can subsequently be used to control focus and radial distances. This method uses precomputed approximating bases of predefined classes of surface faults. In practice this strategy can be non optimal, since a given fault is not always well-described by the approximating bases attached to this class.

This paper suggests an approach for making the feature based control scheme adaptive. In the sense that the approximating basis is adapted to the given fault during playback of the CD. This means that the approximating basis is recomputed after each encounter of the given surface fault.

A short description of the focus and radial servos in the CD-player is given together with a description of the relevant model of the CD-player and surface faults. The general structure of the feature based control scheme is introduced with focus on the fault accommodation part of the feature based control scheme. An adaptive version of the feature based control scheme is subsequently proposed. Simulations of the adaptive feature based control scheme are compared with simulations of feature based control scheme in order to illustrate the improvements of the adaptive scheme. In the end a conclusion is drawn.

P.F. Odgaard, J. Stoustrup and P. Andersen are at Department of Control Engineering, Aalborg University, Fredrik Bajers Vej 7C, DK-9220 Aalborg East, Denmark, {odgaard, jakob, pa}@control.aau.dk

E. Vidal is at Bang & Olufsen A/S, Peter Bangs Vej 15, DK-7600 Struer, Denmark, evs@bang-olufsen.dk

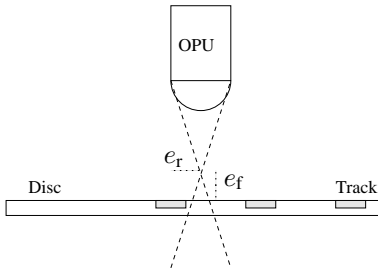

Fig. 1. The focus distance, e_f , is the distance from the focus point of the laser beam to the reflection layer of the disc, the radial distance, e_r , is the distance from the center of the laser beam to the center of the track. The OPU is the Optical Pick-up Unit, which measures four detector signals. These can be used to estimate these distances as well as two residuals, used to detect surface defects as scratches.

II. THE CD-PLAYER

The OPU in the CD-player is focused and radially tracked by movements of the OPU in two directions, called focus and radial directions. These movements are enabled by a two axis device, where linear electro-magnetic actuators are used to perform the actual movements. By moving the OPU in those two directions the focus distance, e_f , and the radial distance, e_r can be minimized. The two distances are illustrated in Fig. 1. The position of the OPU in these two directions is measured by using smart optics in the OPU. The OPU generates four detector signals which can be used to generate the approximations of the distances. Two focus detector signals are denoted D_1 and D_2 , and the two radial distances are denoted S_1 and S_2 . The pair wise differences of these are qualified approximations of the respective distances.

Unfortunately these measurements are influenced by the surface faults. All these are illustrated by Fig. 2. In this figure the signals are defined as follows. $\mathbf{u}[n]$ is a vector of the control signals to the electro-magnetic system, $\mathbf{d}[n]$ is a vector of the unknown disturbances to the electro-magnetic system, $\mathbf{d}_{\text{ref}}[n]$ is a vector of the unknown references, (generated by local disc geometry), to the system, $\mathbf{e}[n]$ is a vector of the focus distances, $\tilde{\mathbf{e}}[n]$ is a vector of the distance components due to the surface fault, $\hat{\mathbf{e}}[n]$ is a vector of the estimated/measured distances, $\beta[n]$ is a vector of scalings of the detector signals due to the surface fault, $\mathbf{s}[n]$ is detector signals without surface faults and $\mathbf{s}_m[n]$ is a vector of the measured detector signals.

A. Model of the electro-magnetic system

The electro-magnetic system in the CD-player is modeled and described in a number of publications. The focus and radial models are much alike, and are often modeled by decoupled second order models, see [6] and [7]. In the discrete time version the model is given by

$$\eta[n+1] = \begin{bmatrix} \mathbf{A}_f & \mathbf{0} \\ \mathbf{0} & \mathbf{A}_r \end{bmatrix} \cdot \eta[n] + \begin{bmatrix} \mathbf{B}_f & \mathbf{0} \\ \mathbf{0} & \mathbf{B}_r \end{bmatrix} \cdot \mathbf{u}[n], \quad (1)$$

$$\begin{bmatrix} e_f[n] \\ e_r[n] \end{bmatrix} = \begin{bmatrix} \mathbf{C}_f & \mathbf{0} \\ \mathbf{0} & \mathbf{C}_r \end{bmatrix} \cdot \eta[n], \quad (2)$$

where $\eta[n] \in \mathcal{R}^4$ is the vector of states in the model, $\mathbf{A}_f \in \mathcal{R}^{2 \times 2}$, $\mathbf{B}_f \in \mathcal{R}^{2 \times 1}$, $\mathbf{C}_f \in \mathcal{R}^{1 \times 2}$ are the model matrices in

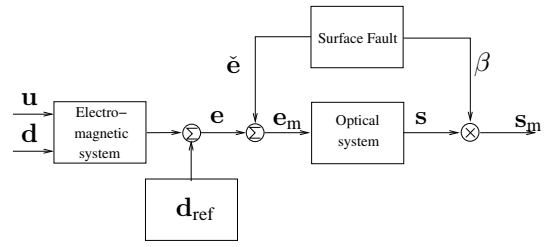

Fig. 2. The principles of the model of the CD-player. The CD-player consists of four parts. The electro-magnetic system and the optical system, the unknown references (in a vector denoted $\mathbf{d}_{\text{ref}}[n]$) and the surface fault. $\mathbf{u}[n]$ is a vector of the control signals to the electro-magnetic system, $\mathbf{d}[n]$ is a vector the unknown disturbances to the electro-magnetic system, $\mathbf{e}[n]$ is a vector of the distances, $e_r[n]$ is the radial distance, $\tilde{\mathbf{e}}[n]$ is a vector of the distance components due to the surface fault, $\hat{\mathbf{e}}[n]$ is a vector of the estimated/measured distances, $\beta[n]$ is a vector of scalings of the detector signals due to the surface fault, $\mathbf{s}[n]$ is a vector of the detector signals without surface faults and $\mathbf{s}_m[n]$ is a vector of the measured detector signals.

the focus model, and $\mathbf{A}_r \in \mathcal{R}^{2 \times 2}$, $\mathbf{B}_r \in \mathcal{R}^{2 \times 1}$, $\mathbf{C}_r \in \mathcal{R}^{1 \times 2}$ are the model matrices in the radial model. This model is somewhat simplified, but sufficient for our purposes.

B. Model of the optical detectors

This optical model is expressed by the vector mapping, described in (3),

$$\mathbf{f} : \begin{bmatrix} e_f[n] \\ e_r[n] \end{bmatrix} \rightarrow \begin{bmatrix} D_1[n] \\ D_2[n] \\ S_1[n] \\ S_2[n] \end{bmatrix}, \quad (3)$$

where $D_1[n]$ and $D_2[n]$ are the two focus detectors and $S_1[n]$ and $S_2[n]$ are the two radial detectors. The four coordinate functions of \mathbf{f} can be simplified in the following manner, (see [8]),

$$f_i(e_f[n], e_r[n]) \approx h_i(e_f[n]) \cdot g_i(e_r[n]), \quad (4)$$

where

$$i \in \{1, 2, 3, 4\}, \quad (5)$$

moreover

$$g_1(e_r[n]) = g_2(e_r[n]). \quad (6)$$

In [8], detailed optical models are described. In practice it is useful to simplify this model, in [8] and [9] it is suggested to approximate $h_i(e_f[n])$ and $g_i(e_r[n])$ with cubic splines.

C. Model of the surface faults

The surface faults decrease the energy received in all the detectors. This can be described by scaling the photo detector signals, such that the two focus detectors are scaled with one scale, $\beta_f[n]$, and the two radial detectors are scaled with another one, $\beta_r[n]$. However, if these scalings were the only influence from the surface faults on the detector signals, the surface fault components could be removed from the detector signals by normalization of the detector signals. The surface faults introduce a pair of faulty distance components represented by a vector $\tilde{\mathbf{e}}[n]$, see [10] and [11]. These surface

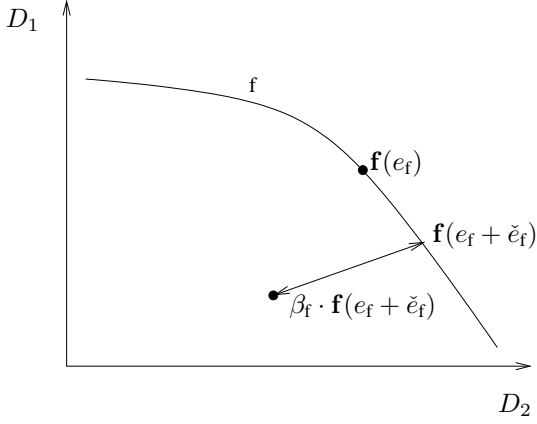

Fig. 3. Illustration of how the surface faults influence the focus measurements D_1 and D_2 . $\beta_f \cdot \mathbf{f}(e_f + \tilde{e}_f)$ is the measured point parameterized with β and \tilde{e}_f . $\mathbf{f}(e_f)$ is point where the measurements would have been if no surface fault has been present.

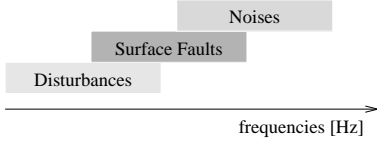

Fig. 4. An illustration of how the frequency region of the surface faults is overlapping both the frequency region of disturbances and measurement noises.

faults components are illustrated for the focus detector in Fig. 3. This leads to the following model of the detector signals during a surface fault,

$$\mathbf{s}_m[n] = \begin{bmatrix} \beta_f[n] \cdot \mathbf{I} & \mathbf{0} \\ \mathbf{0} & \beta_r[n] \cdot \mathbf{I} \end{bmatrix} \cdot \mathbf{f}(e[n] + \tilde{e}[n]). \quad (7)$$

An important observation which is made in [5] and [12], states that a surface fault does not vary much from one encounter to the next encounter.

D. The problem in handling surface faults

Based on the models of the CD-player and the surface faults, one could draw the conclusion that surface faults can be viewed as measurement noises. However, a controller design based on this idea is not a very qualified solution to this problem of handling surface faults. The disturbances and measurement noises are in the CD-player example reasonably well separated in frequencies, meaning that it is possible to cover the disturbances in frequencies by the sensitivity of the controller and to cover the measurement noises by complementary sensitivity function. However, the frequency region of the surface faults is partly in the region of the disturbances and partly in the region of the measurement noises, as illustrated in Fig. 4. Disturbances are due to mechanical shocks, deformations of the disk and track, etc. An example on measurement noise is internal electromagnetic noises in the CD-player. I.e. if the surface faults are included in the measurement noises it is not possible to separate disturbances from measurement noises in the frequency domain.

III. FEATURE BASED CONTROL

In this section the core idea of the feature based control scheme of the CD-player will be described briefly. The idea in short is that the signals, $\alpha_f = 1 - \beta_f$ and $\alpha_r = 1 - \beta_r$, are used to detect and locate the surface faults on the time axis. The feature extraction presented in [13] gives a classification of faults. Approximating coefficients of the surface faults in a given basis representing a class of faults have been presented in [11]. This approximation of the surface faults is used to remove the fault component from the measurement of the next surface fault encounter based on the previous encounters. The standard focus and radial controllers can be used, since the fault component is removed from the detector signals.

The feature based control strategy is illustrated in Fig. 5, from which it can be seen that the feature based control strategy consists of: Residual & Distance Estimator, Feature Extraction/Fault Detection, Fault Accommodation and a Controller. $\mathbf{s}_m[n]$ is a vector of the measured detector signals, α is a vector of the residuals, $\tilde{\mathbf{e}}[n]$ is a vector of the distance measurements, $\mathbf{f}_d[n]$ is a vector of the fault detection signals, these takes the value 1 in case of a detected fault and 0 elsewhere, $\hat{\mathbf{e}}[n]$ is a vector of estimates of distances due to the control signals, $\bar{\mathbf{e}}[n] = \tilde{\mathbf{e}}[n] - \hat{\mathbf{e}}[n]$ is a vector of the part of distances which are unrelated to the control signals, $\hat{\mathbf{e}}[n]$ is a vector of the corrected distances, $\mathbf{u}[n]$ is a vector of the control signals. One should notice that $\bar{\mathbf{e}}[n]$ contains more than just the distance fault components, in addition $\bar{\mathbf{e}}[n]$ contains disturbances and noises. I.e. filtering is necessary in order to estimate the fault components.

This filtering is performed by subtracting approximation of the fault components from the measurements. The estimations of the fault components are performed by the use of Karhunen-Loève bases, see [14], computed based on $\bar{\mathbf{e}}[n]$ containing measured surface faults. Denote the matrices with focus and radial $\bar{\mathbf{e}}[n]$ measurements as column vectors: \mathbf{D}_f and \mathbf{D}_r respectively, see [5]. The approximating bases can subsequently be computed as the Karhunen-Loève basis of

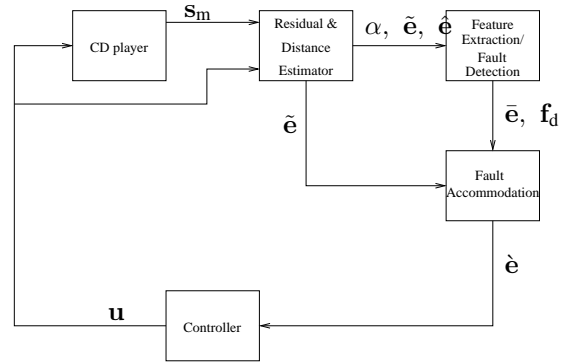

Fig. 5. Illustration of the structure of the feature based control scheme, to handle surface faults as faults. \mathbf{s}_m is a vector of the measured detector signals, α is a vector of the residuals, $\tilde{\mathbf{e}}$ is a vector of the distance measurements, \mathbf{f}_d is a vector of the fault detection signals, $\hat{\mathbf{e}}$ is a vector of estimates of distances due to the control signals, $\bar{\mathbf{e}}$ is a vector of the distances parts not depending on the control signals, $\hat{\mathbf{e}}$ is a vector of the corrected distances, \mathbf{u} is a vector of the control signals.

these matrices. A number of the most approximating basis vectors are used for the approximation, since these few basis vectors approximates the general structures in data matrices, and the remaining ones support the noises in the data vectors. In this application, this separation between signal and noise, removes the fault component from the disturbances and noises by filtering. The surface fault does not change much from encounter to encounter, whereas disturbances and noises can be assumed to vary from encounter to encounter. I.e. the surface component is the general signal structure and the disturbances and noises are filtered by this approximation,

$$\mathbf{K}_{\tilde{\epsilon}} = \{\text{eigenvector}(\mathbf{D}_f \cdot \mathbf{D}_f^T)\}, \quad (8)$$

and the approximating part of \mathbf{K}_{e_f} denoted $\mathbf{K}_{\tilde{e}_f}$ is

$$\mathbf{K}_{\tilde{e}_f} = \mathbf{K}_{e_f} \{N - \kappa + 1 \cdots N\}, \quad (9)$$

where κ is the number of used approximating vectors. In this application κ is equal 4. The approximating radial basis can be defined likewise,

$$\mathbf{K}_{\tilde{e}_r} = \mathbf{K}_{e_r} \{N - \kappa + 1 \cdots N\}. \quad (10)$$

A. The feature based control algorithm

The feature based control algorithm is presented in [5] and [12].

The fault correction algorithm can now be stated:

- 1) Detect the fault and locate its position in time, when the fault is detected at sample n , $f_d[n] = 1$.
- 2) If $f_d[n] = 1$:

$$a = \begin{cases} 0 & \text{if } f_d[n-1] = 0, \\ a+1 & \text{if } f_d[n-1] = 1. \end{cases}$$

$$\tilde{e}[n] = \tilde{e}[n] - \begin{bmatrix} \tilde{e}_f[l] \\ \tilde{e}_r[l] \end{bmatrix},$$

where

$$\iota = ((L - l_f) \text{ div } (2)) + a,$$

where L is the length of the correction block, (in the used example $L = 256$), a is a counter counting the number of samples the given fault is present, finally ι is a counter used to locate the given sample relative to the fault correction block.

- 3) When the fault has been passed, classify the fault, compute the samples where the fault begins and ends, and compute the fault length l_f .
- 4) Compute the focus correction block coefficients by: $\mathbf{k}_f = \mathbf{K}_{\tilde{e}_f} \cdot \tilde{e}_f[v]$ and the radial correction coefficients by: $\mathbf{k}_r = \mathbf{K}_{\tilde{e}_r} \cdot \tilde{e}_r[v]$, where v is the interval of L samples in which the fault is present.
- 5) Compute the focus fault removal correction block by: $\tilde{\tilde{e}}_f = \mathbf{K}_{\tilde{e}_f} \cdot \mathbf{k}_f$, and the radial fault removal correction by: $\tilde{\tilde{e}}_r = \mathbf{K}_{\tilde{e}_r} \cdot \mathbf{k}_r$.

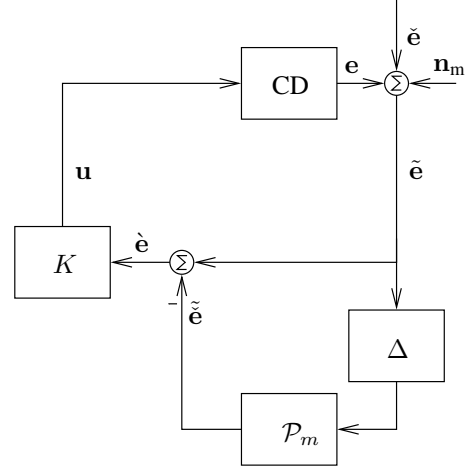

Fig. 6. Illustration of the closed loop with the feature based correction \mathcal{P}_m at encounter m , for the non-adaptive feature based control scheme, $\mathcal{P}_m = \mathcal{P}$, and time invariant. K is the controller, and CD is the CD-player. Δ is the unit revolution delay. \mathbf{u} is a vector of the control signals, \mathbf{e} is a vector of focus and radial distances, $\tilde{\mathbf{e}}$ is a vector of faulty sensor components due to the surface fault, $\tilde{\tilde{\mathbf{e}}}$ is a vector of the estimates of the faulty sensor components due to the surface fault. $\tilde{\mathbf{e}}$ is a vector of the measured distance signals and \mathbf{n}_m is a vector of the measurement noises.

B. Stability of the scheme

A stability criterion for this feature based control scheme is derived in [5] and [11]. The criterion is given by Lemma 1.

Define the following matrices. \mathcal{P}^L is the lifted approximating basis system, and it can be computed by

$$\mathcal{P}^L = \mathbf{K}_{\tilde{\epsilon}} \cdot \mathbf{K}_{\tilde{\epsilon}}^T, \quad (11)$$

and the lifted representation of the complementary sensitivity is

$$T^L = \begin{bmatrix} h_0 & 0 & \cdots & 0 \\ h_1 & h_0 & & \vdots \\ \vdots & & \ddots & \\ h_{255} & \cdots & & h_0 \end{bmatrix}, \quad (12)$$

where $\mathbf{h} = [h_0 \ h_1 \ \cdots \ h_{255}]$ is time series of L samples of the impulse response of T .

Lemma 1 *The feature based control system defined by Fig. 6 is stable if and only if: $\max(|\text{eig}(T^L \mathcal{P}^L)|) < 1$, where \mathcal{P}^L is defined in (11) and T^L is defined in (12).*

IV. ADAPTIVE FEATURE BASED CONTROL

The use of the fault handling method proposed in [5] and [12] introduces a potential problem. The approximating basis is precomputed being the best approximation basis of the entire fault class. However, in most cases it will be possible to compute a basis which approximates the fault much better than the basis for the given class of fault. This can be accommodated by extending the feature based control algorithm with an update of the approximating basis after each encounter with the surface fault.

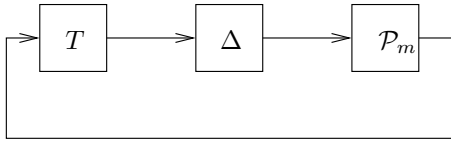

Fig. 7. Closed loop of the adaptive feature based control system. T is the complementary sensitivity of the nominal system, Δ is the unit revolution delay, and \mathcal{P}_m is the feature based fault handling.

This update consists of the following steps: Extract the data containing the focus and radial signals of the recent encounter of the fault. This extracted data is subsequently augmented with a matrix storing the past fault encounters. The augmented data matrix is following used to compute the new set of approximating vectors by the Karhunen-Loève transform. The computation of the approximation of the fault is the same as in the standard feature based control scheme, see (8-10). However, stability is an issue which one should be aware of.

A. Stability of adaptive feature based control algorithm

The stability issue of the adaptive version of feature based control scheme is not the same as in the standard case, since the merged system in the adaptive scheme is linear time variant in contrast with the non-adaptive scheme.

In order to derive a stability criterion, the complementary sensitivity of the nominal servo system and the adaptive \mathcal{P} at encounter m are lifted, meaning that both part systems are represented by a discrete time series of a given length. The stability of the scheme can be dealt with in this way since p is so large that the response of a fault encounter is dead before the next fault encounter.

The lifted \mathcal{P} can be computed by

$$\mathcal{P}_m^L = \mathbf{K}_{\tilde{e}_m} \cdot \mathbf{K}_{\tilde{e}_m}^T, \quad (13)$$

where $\mathbf{K}_{\tilde{e}_m}$ is matrix representation of the approximation filter computed at encounter m , and the lifted representation of the complementary sensitivity at encounter m is

$$T^L = \begin{bmatrix} h_0 & 0 & \cdots & 0 \\ h_1 & h_0 & & \vdots \\ \vdots & & \ddots & \\ h_{255} & \cdots & & h_0 \end{bmatrix}, \quad (14)$$

where $\mathbf{h} = [h_0 \ h_1 \ \cdots \ h_{255}]$ is time series of L samples of the impulse response of T .

By lifting the system illustrated in Fig. 7 one gets a set of discrete time varying difference equations of the form, if :

$$\xi[N+1] = \mathbf{A}_m \xi[N] + \mathbf{K} \mathbf{u}[N], \quad (15)$$

where $\mathbf{A} = T^L \mathcal{P}_m^L$, and ξ is the related state vector. These definitions make it possible to state Lemma 2, which says that the adaptive feature based control scheme is stable if a certain requirement is fulfilled.

Lemma 2 *The adaptive feature based control system defined by Fig. 6, which is stable if and only if: $\max_m (\bar{\sigma}(T^L \mathcal{P}_m^L)) <$*

1, where \mathcal{P}_m^L is defined in (13) and T^L is defined in (14).

3 Proof of Lemma

Necessary and sufficient conditions:

The stability of the closed loop system shown in Fig. 6 which is equivalent to stability of the system in (15), which is a linear time varying discrete time system, from which the result follows, the system is stable if and only if $\max_m (\bar{\sigma}(A_m)) = \max_m (\bar{\sigma}(T^L \mathcal{P}_m^L)) < 1$.

The system response through $T_L \mathcal{P}_m^L$ will converge towards zero if the maximum singular value of $T_L \mathcal{P}_m^L$ is strictly less than one for all m , meaning that the system represented by $T_L \mathcal{P}_m^L$ is stable if $\max_m (\bar{\sigma}(T^L \mathcal{P}_m^L)) < 1$.

The stability shall be checked each time a new approximating basis has been computed. The stability problem occurs if the sensitivity of the closed loop is amplified too much at given frequencies through the approximating basis. This might happen if a given fault has a very low frequency content, and as the adaptive approximating basis covers these frequencies more and more, the stability margin of the system decreases. This might end in instability of the system.

The stability check procedure is as follows: When a new approximating basis is computed, determine if the new system is stable using Lemma 2. If the system is stable use the newly computed approximating basis, if not use the latest stable computed basis.

B. The algorithm of the adaptive feature based control strategy

The adaptive fault correction algorithm can now be stated:

- 1) As step 1 in the feature based control scheme, see Subsection III-A.
- 2) As step 2 in the feature based control scheme, see Subsection III-A.
- 3) When the fault has been passed, determine the location of the the fault in time, compute the fault length l_f , and update \mathbf{D}_f and \mathbf{D}_r with vectors containing the past fault. If the data matrices are too large, the oldest fault vector in each matrix is removed.
- 4) Compute the focus approximating basis by: $\mathbf{K}_{\tilde{e}_f} = \{\text{eigenvector}(\mathbf{D}_f \cdot \mathbf{D}_f^T)\}_{\{N - \kappa + 1 \cdots N\}}$, and the radial approximating basis by: $\mathbf{K}_{\tilde{e}_r} = \{\text{eigenvector}(\mathbf{D}_r \cdot \mathbf{D}_r^T)\}_{\{N - \kappa + 1 \cdots N\}}$.
- 5) Check stability using Lemma 2. If the system is stable use the newly computed approximating basis, if not use the latest computed stable basis.
- 6) Compute the focus correction block coefficients by: $\mathbf{k}_f = \mathbf{K}_{\tilde{e}_f} \cdot \tilde{e}_f[v]$ and the radial correction coefficients by: $\mathbf{k}_r = \mathbf{K}_{\tilde{e}_r} \cdot \tilde{e}_r[v]$, where v is the interval of L samples in which the fault is present.
- 7) Compute the focus fault removal correction block by: $\tilde{\tilde{e}}_f = \mathbf{K}_{\tilde{e}_f} \cdot \mathbf{k}_f$, and the radial fault removal correction by: $\tilde{\tilde{e}}_r = \mathbf{K}_{\tilde{e}_r} \cdot \mathbf{k}_r$.

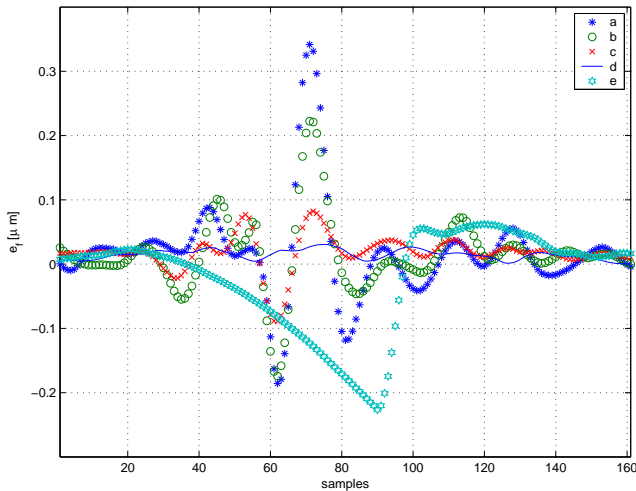

Fig. 8. A zoom on focus distance during the handling at the same fault in five different ways. a) in case of no correction, b) handled by the feature based control scheme, c) handled by the adaptive scheme after 4 encounters of the fault, d) handled by the adaptive scheme after 9 encounters of the fault, and e) standard industrial fault handling method.

V. SIMULATION

The adaptive feature based control scheme is tested by simulations, using a simulation model of a CD-player playing a CD with a surface fault, see [11]. In order to make the simulations challenging the variance of the fault from encounter to encounter is increased with a factor of 3. In the simulation model the surface faults are generated based on statistics of measured faults transformed by the approximating basis. In simulation the basis vectors used for the fault generation are modified such that the standard approximating basis is not a good representation anymore, both still close to it.

The output of this simulation is illustrated by Fig. 8, which shows five zooms on the system's reaction on the fault, in five different situations: no correction, the standard feature based control scheme, the adaptive feature based control scheme after 4 and 9 fault encounters and the standard industrial fault handling method. From this it can be seen that the feature based scheme improves the handling, but not as good as the two adaptive handlings, and the industrial scheme. It is also seen that adaptive feature based method is clearly better than the industrial method. The adaptive handling improves as the number of encounters increase. However, in the simulations the improvements seem to converge at the 9th fault encounter. The plotted results are chosen, since they are a good representative for a number of different simulations of both focus and radial loops. It can thereby be concluded that an adaptive feature based control scheme is an improvement of the feature based scheme in terms of CD-players handling surface faults on the disk surface. In all the simulations made of the adaptive feature based control scheme, the stability

criterion has been fulfilled at all encounters.

VI. CONCLUSION

In previous work of the same authors a feature based control scheme designed for CD-players playing CDs with surface faults is derived and described. In this paper an adaptive version of this feature based control scheme is proposed and described. This adaptive scheme can in contrast to the previous scheme adapt to the given fault, and thereby handle the surface faults in a better way, measured in terms of the controller reaction to the surface faults. The improvements of this adaptive scheme is illustrated by simulations, with the result that the adaptive scheme clearly adapts better to the given faults compared the non-adaptive version of the feature based control scheme. In addition a stability criterion for the adaptive feature based control scheme is derived.

VII. ACKNOWLEDGMENT

The authors acknowledge the Danish Technical Research Council, for support to the research program WAVES (Wavelets in Audio Visual Electronic Systems), grant no. 56-00-0143.

REFERENCES

- [1] Philips, *Product specification: Digital servo processor DSIC2, TDA1301T*, Philips Semiconductors, Eindhoven, The Netherlands, March 1994.
- [2] M. Steinbuch, G. Schoostra, and O. Bosgra, "Robust control of a compact disc player," in *Proceedings of the 31st IEEE Conference on Decision and Control*, Tucson, Arizona, USA, December 1992.
- [3] W. Draijer, M. Steinbuch, and O. Bosgra, "Adaptive control of the radial servo system of a compact disc player," *Automatica*, vol. 28, no. 3, pp. 455-462, May 1992.
- [4] E. Vidal Sánchez, "Robust and fault tolerant control of cd-players," Ph.D. dissertation, Department of Control Engineering, Aalborg University, 2003, ISBN: 87-90664-15-9.
- [5] P. F. Odgaard, "Feature based control of compact disc players," Ph.D. dissertation, Department of Control Engineering, Aalborg University, 2004, ISBN: 87-90664-19-1.
- [6] S. G. Stan, *The CD-ROM drive*. Kluwer Academic Publishers, 1998.
- [7] W. Bouwhuis, J. Braat, A. Huijser, J. Pasman, G. van Rosmalen, and K. Schouhamer Immink, *Principles of Optical Disc Systems*. Adam Hilger Ltd, 1985.
- [8] P. Odgaard, J. Stoustrup, P. Andersen, and H. Mikkelsen, "Modelling of the optical detector system in a compact disc player," in *Proceedings of the 2003 American Control Conference*, Denver, Colorado, USA, June 2003.
- [9] —, "Fault detection for compact disc players based on redundant and non-linear sensors," in *Proceedings of American Control Conference 2004*, Boston, Massachusetts, USA, June-July 2004.
- [10] —, "Extracting focus and radial distances, fault features from CD player sensor signals by use of a kalman estimator," in *Proceedings of the 42nd IEEE Conference on Decision and Control*, Maui, Hawaii, USA, December 2003.
- [11] P. Odgaard, J. Stoustrup, P. Andersen, M. Wickerhauser, and H. Mikkelsen, "A simulation model of focus and radial servos in compact disc players with disc surface defects," in *Proceedings of the 2004 IEEE CCA/ISIC/CACSD*, Taipei, Taiwan, September 2004.
- [12] —, "A fault tolerant control scheme for CD players to handle surface defects," 2004, submitted for journal publication.
- [13] P. Odgaard and M. Wickerhauser, "Discrimination between different kind of surface defects on compact discs," in *Proceedings of the 30th Annual Conference of the IEEE Industrial Electronics Society IECON'04.*, November 2004.
- [14] S. Mallat, *A wavelet tour of signal processing*, second. ed. Academic Press, 1999.