



Aalborg Universitet

AALBORG UNIVERSITY
DENMARK

Model Test Setup and Program for Experimental Estimation of Surface Loads of the SSG Kvitsøy Pilot Plant from Extreme Wave Conditions

Kofoed, Jens Peter; Larsen, Brian Juul

Publication date:
2005

Document Version
Publisher's PDF, also known as Version of record

[Link to publication from Aalborg University](#)

Citation for published version (APA):

Kofoed, J. P., & Larsen, B. J. (2005). Model Test Setup and Program for Experimental Estimation of Surface Loads of the SSG Kvitsøy Pilot Plant from Extreme Wave Conditions. Aalborg: Department of Civil Engineering, Aalborg University. (Hydraulics and Coastal Engineering; No. 32).

General rights

Copyright and moral rights for the publications made accessible in the public portal are retained by the authors and/or other copyright owners and it is a condition of accessing publications that users recognise and abide by the legal requirements associated with these rights.

- ? Users may download and print one copy of any publication from the public portal for the purpose of private study or research.
- ? You may not further distribute the material or use it for any profit-making activity or commercial gain
- ? You may freely distribute the URL identifying the publication in the public portal ?

Take down policy

If you believe that this document breaches copyright please contact us at vbn@aub.aau.dk providing details, and we will remove access to the work immediately and investigate your claim.

Model Test Setup and Program for Experimental Estimation of Surface Loads of the SSG Kvitsøy Pilot Plant from Extreme Wave Conditions



according to Co-operation Agreement (phase 4) between
WAVEenergy (Norway) and Aalborg University, Dept. of Civil Engineering

Brian Juul Larsen & Jens Peter Kofoed, Aalborg University

October, 2005



DEPARTMENT OF CIVIL ENGINEERING
AALBORG UNIVERSITY
SOHNGAARDSHOLMSVEJ 57 DK-9000 AALBORG DENMARK
TELEPHONE +45 96 35 80 80 TELEFAX +45 98 14 25 55

Hydraulics and Coastal Engineering No. 32

ISSN: 1603-9874

Model Test Setup and Program for Experimental Estimation of Surface Loads of the SSG Kvitsøy Pilot Plant from Extreme Wave Conditions

by

Brian Juul Jensen & Jens Peter Kofoed, Aalborg University

October, 2005

Preface

This report presents the preparations done prior to model tests planned for November 2005 focusing on experimental estimation of the surface loads on the wave energy convert (WEC) Seawave Slot-Cone Generator (SSG) due to extreme wave conditions. SSG is a WEC utilizing wave overtopping in multiple reservoirs. In the present SSG setup three reservoirs have been used.

Model tests are planned using a model (length scale 1:60) of the SSG prototype at the planned location of a pilot plant at the west coast of the island Kvitsøy near Stavanger, Norway. The properties of the coastal area surrounding the planned pilot plant site is also modeled. The tests will be carried out at Dept. of Civil Engineering, Aalborg University (AAU) in the 3D deep water wave tank.

The preparations have been carried out by Brian Juul Larsen and Jens Peter Kofoed, AAU, in co-operation with Espen Osaland, WAVEenergy, Norway (WE). The report has been prepared by Brian Juul Larsen and Jens Peter Kofoed (tlf.: +45 9635 8474, e-mail: jpk@civil.aau.dk).

The work has been carried out according to a Co-operation Agreement (phase 4) between WAVEenergy (WE) and Aalborg University, Dept. of Civil Engineering.

Aalborg, October, 2005.

Table of Contents

1	INTRODUCTION.....	3
2	DESIGN SEA STATES	5
2.1	THE NORSOK METHOD	5
2.2	STATOIL REFRACTION ANALYSIS	5
2.3	HINDCAST DATA ANALYSIS	5
2.3.1	<i>Comparison between Locations</i>	7
2.4	DEPTH LIMITATION	9
2.5	HIGH WATER LEVEL	11
2.6	CONCLUSION	11
3	TEST PROGRAM	13
4	MODEL TEST SETUP.....	15
4.1	DESCRIPTION OF BATHYMETRY	15
4.2	BUILD-UP OF THE MODEL	16
4.3	WAVE GENERATION	19
4.4	INSTRUMENTATION	20
4.4.1	<i>Calibration</i>	22
4.5	DATA ACQUISITION AND ANALYSIS	22
5	SUMMARY	23
6	REFERENCES.....	25

1 Introduction

The purpose of the tests is to find the wave induced surface loads on the SSG pilot plant when exposed to extreme wave conditions, ie. the design loads.

The design sea states used in the model tests are found through a study of the wave climate from a number of different sources, as described in chapter 2.

Based on the hereby obtained extreme wave data for the SSG pilot plant location a test program has been designed to establish the surface loads on the SSG pilot plant in various relevant sea states, see chapter 3.

A description of the test setup and the model is made in detail – including a description of the instrumentation and data acquisition and also the data analysis.

2 Design Sea States

2.1 The NORSOK Method

According to NORSOK (1999) the following sea-state parameters has an annual exceedance probability of 0.01 for sea-states of 3 hours duration west of the Kvitsøy test site (offshore):

- $H_{m0} = 14.5$ m
- $T_p = 16$ s

The maximum single wave height H_{100} is assumed to be 1.9 times H_{m0} in NORSOK. The period T used in conjunction with H_{100} should be varied in the following range:

$$\sqrt{6.5H_{100}} \leq T \leq \sqrt{11H_{100}}$$

H_{100} would then be 27.6 m and the T would be between 13.4 s and 17.4 s.

2.2 Statoil Refraction Analysis

Statoil has gathered material on waves from 1955 to 2001. The hindcast data is from grid point 1312. In table 1 the 100 years extreme events of the offshore environment near the test site are shown to the left. Due to refraction and diffraction in the near shore environment those offshore conditions gives the conditions on the plateau in front of the structure that are listed to the right in table 1.

		Offshore			Plateau	
		Θ [°]	H_s [m]	T_p [s]	Θ [°]	H_s [m]
		150	10.3	14.0	185	2.5
S		180	11.7	14.8	195	4.5
		210	10.8	14.3	225	5.5
		240	10.8	14.3	240	10.5
W		270	12.5	15.2	270	12.5
		300	13.2	15.6	285	9.5
		330	14.3	16.2	300	5.5
N		0	14.3	16.2	315	2.5

Table 1. 100 years extreme events.

The waves from West (270°) are head-on waves.

2.3 Hindcast Data Analysis

Hindcast wave data from grid points 1261 and 1262, DNMI, has been analyzed with a P.O.T. analysis. H_s , T_p and direction have been measured every six hours since 1955. The largest H_s measured are:

Grid Point	H_s [m]	T_p [s]	Direction
1261	12.06	15.2	NW
1262	8.61	12.7	W

Table 2. Largest H_s measured.

A threshold (x') has been set and 26 uncorrelated extreme wave heights have been identified for both grid points. In order to be considered as uncorrelated (from two different storm events) the extreme data has to be separated by more than 12 hours. In figure 1 and 2 the extreme wave heights have been plotted with Weibull's plotting formula. $F_i = i / N + 1$.

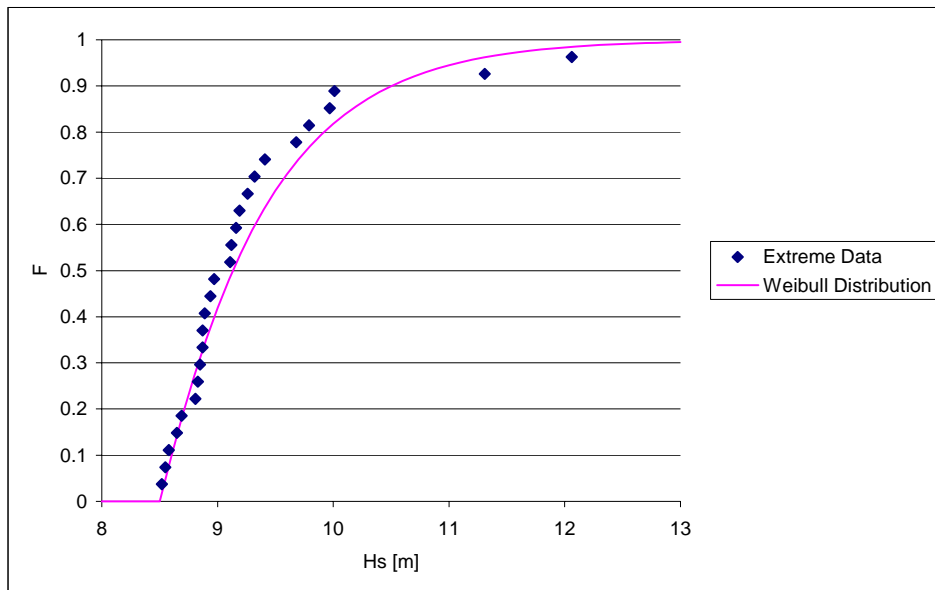

Figure 1. Extreme data for grid point 1261.

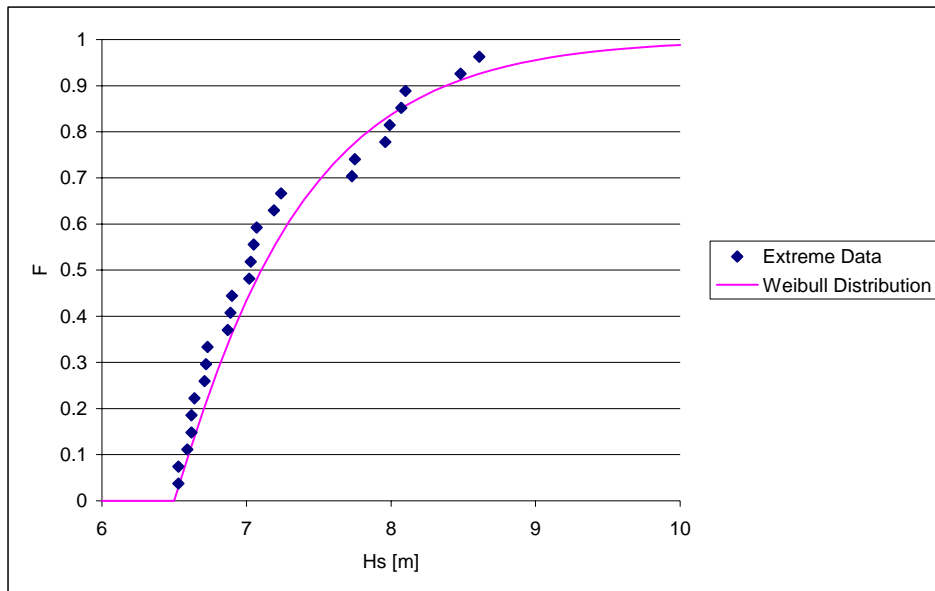

Figure 2. Extreme data for grid point 1262.

Weibull distributions have been calculated.

$$F = 1 - e^{-\left(\frac{x-x'}{A}\right)^k}$$

Grid Point	A	k	x'
1261	0.90	1.041	8.5 m
1262	0.85	1.055	6.5 m

Table 3. Distribution parameters.

H_s with a return period of 100 years then becomes 11.87 m for grid point 1261 and 9.64 m for grid point 1262.

2.3.1 Comparison between Locations

From November 4th 2004 to March 11th 2005 the waves approximately 400 meters west of the test site have been measured. In figure 3 the 12th of January 2005 (Storm “Inga”) is used to show a comparison between the data from grid points 1261 and 1262 and the data from the test site.

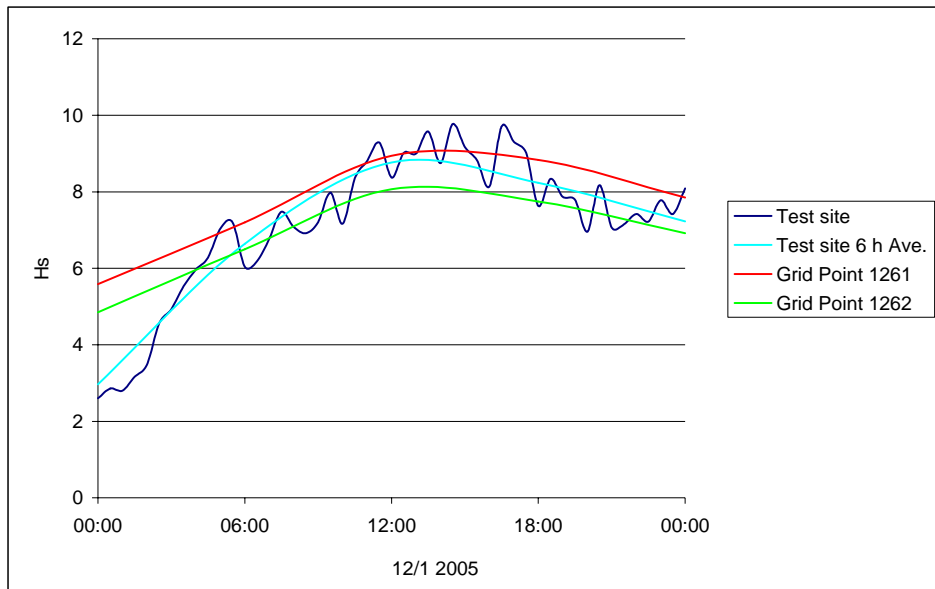

Figure 3. Comparison of H_s .

So far the largest observed H_s over half an hour on the test site is 9.77 m reached on the 12th of January 2005 at 14:30. T_p was 14.8 s. Seen as an average over six hours as with the hindcast data from grid point 1261 and 1262 the largest H_s is 8.77 m. As it can be seen on figure 4 1262 lies closer to the test site than 1261. However, as it can be seen from figure 3 data from grid point 1261 seems to give a better representation for the test site. 1262 underestimate the waves and 1261 gives a slight overestimation. For a conservative approach 1261 should be used.

Furthermore, it was found that the maximum height of a single wave during the storm was 17.78 m. This occurred at 11.30 where the half hour H_s was 9.29 m (17.78 m / 1.91). If the maximum height is compared to the six hour H_s the ratio H_{max}/H_s is 2.03, i.e. considerably higher than 1.90 as given in section 2.1.

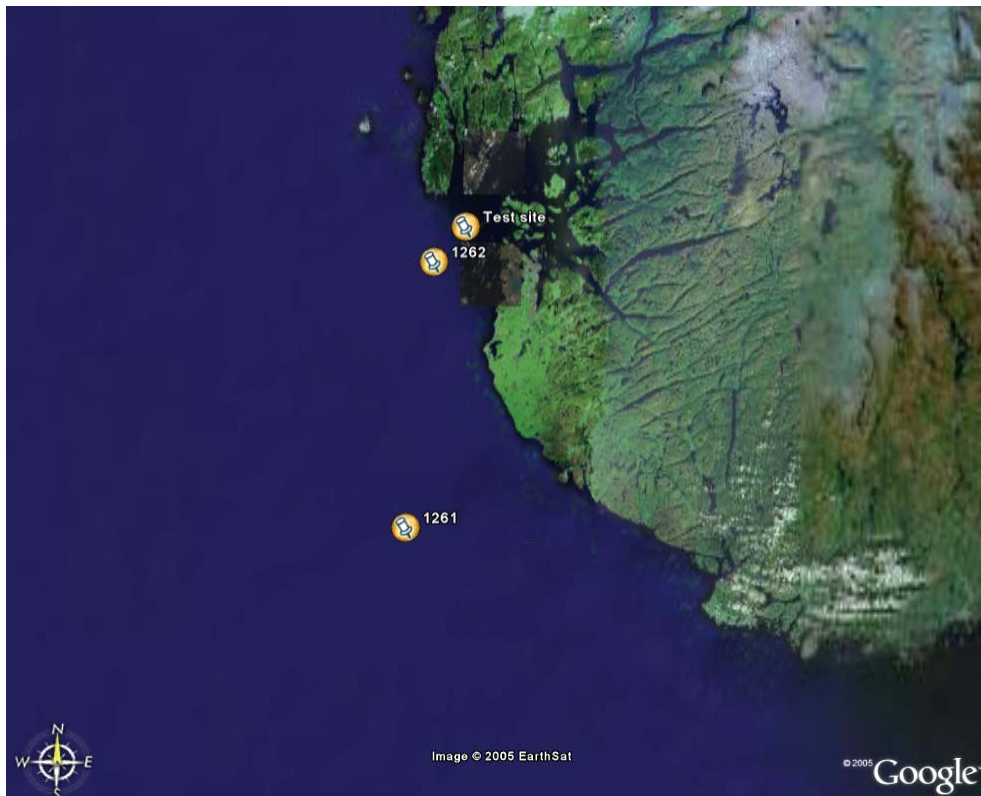

Figure 4. Global placement of grid point 1261, 1262 and the test site.

2.4 Depth Limitation

West of the considered location the water depth is +100 meters. The plateau in front of the structure is approximately 300 meters in stretch and the depth is roughly speaking 30 meters on the entire plateau.

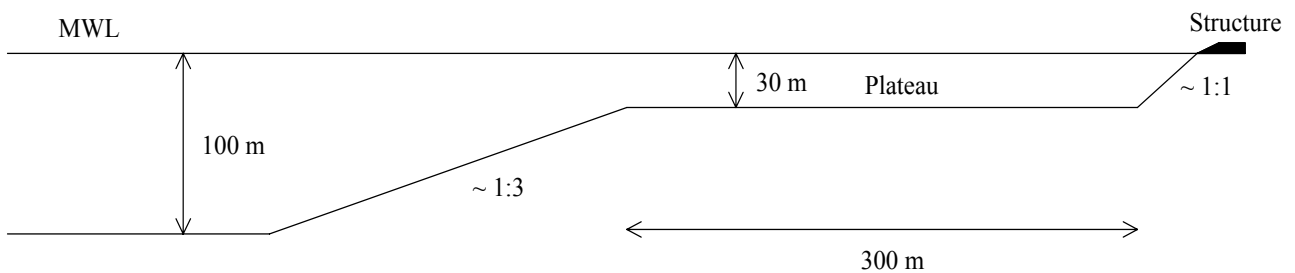

Figure 5. Rough sketch of the foreshore.

Therefore waves of less than 15 meters can not be expected to break on the plateau. If the waves are assumed no higher than $0.8 \cdot h$ and $\frac{H}{L} = 0.142 \cdot \tanh\left(\frac{2 \cdot \pi \cdot h}{L}\right)$ in the near shore environment the largest possible wave height on the plateau would be 24 meters. In rough the bathymetry can also be seen from the sea map in figure 6.

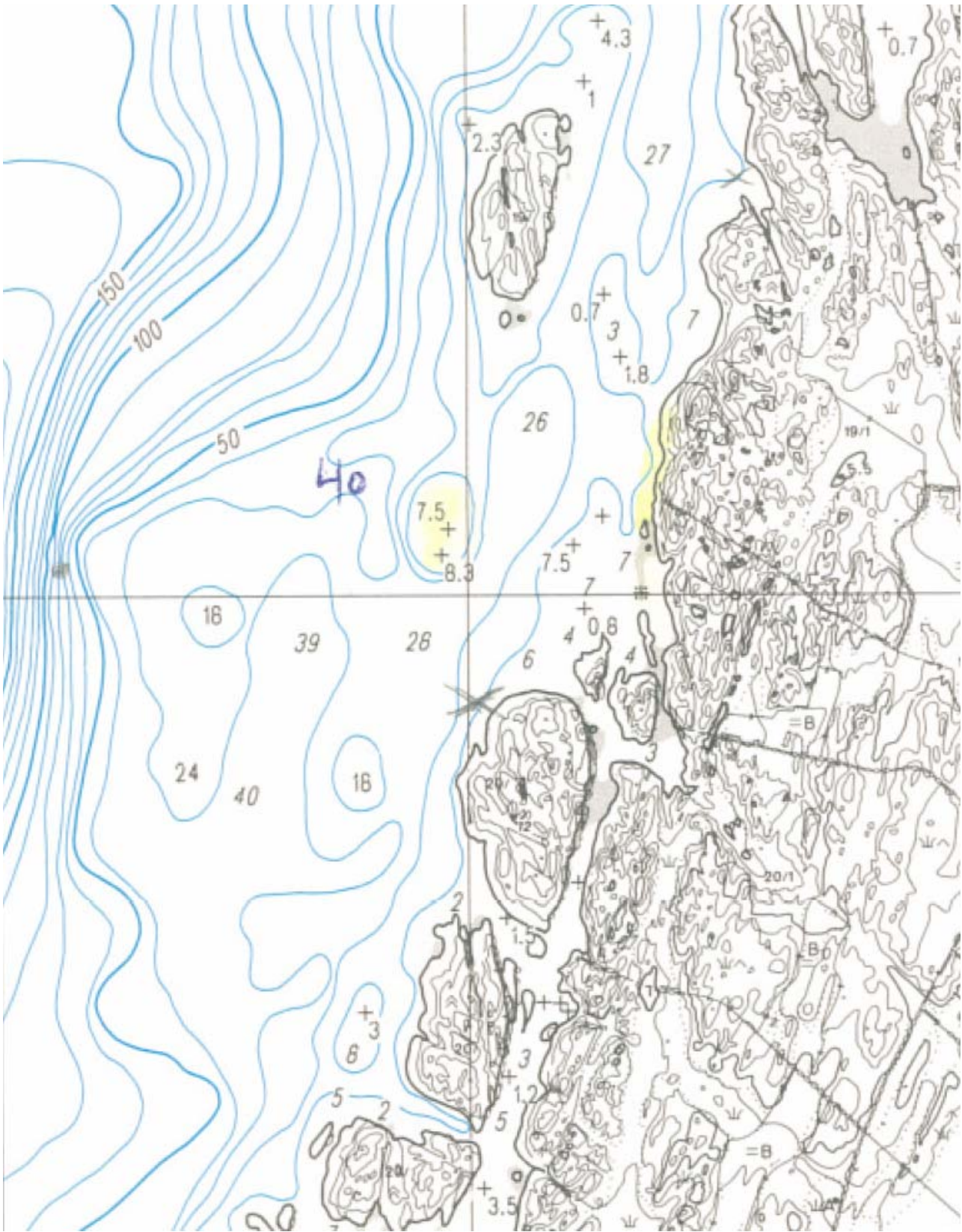

Figure 6. Sea map of the SSG pilot plant test site.

2.5 High Water Level

The variation of the water level in the region has been measured each 10 minutes all through the year 2000. The highest level above mean water level reached in one year was 1.54 m. (Reached at 15:50 on the 29th of January).

2.6 Conclusion

The results from the study described above are summarized in table 4.

It is recommended that the structure is tested for wave attacking at two different angls. For head-on waves the 100 year event at the plateau can be given by wave condition $H_s = 12.5$ m and $T_p = 15.2$ s, based on the Statoil Refraction Analysis.

	H_s [m]	T_p [s]	H_{100} [m]	T_{100} [s]
NORSOK	14.5	16.0	27.6	13.4 – 17.4
Statoil				
Offshore	14.3	16.2	26.6	13.1 – 17.1
Plateau	12.5	15.2	23.3	12.3 – 16.0
Hindcast				
1261	11.9	15.2	22.1	12.0 – 15.6
1262	9.6	12.7	17.9	10.8 – 14.0
Test site	8.8	14.8	16.4	10.3 – 13.4
Max on plateau			24.0	12.5 – 16.2

Table 4. Summary.

The waves attacking from a SW direction is not considered to be critical, although the waves from these directions are larger than the ones from a NW direction. This is due to the local bathymetry at the location of the structure which shelters the structure from the waves from a SW direction.

Therefore, it is recommended that tests are carried out with oblique waves from the northern side where the largest and most critical fetches are between 270° - 315° (W – NW). According to table 1 it would be on the safe side to test waves in an angel of 315° with H_s up to 5.5 m.

Based on the available tide information the extreme wave condition should be considered with a water level at least 1.54 m above normal. However the data referred to in section 2.5 only covers one year. Therefore it is recommended either to obtain tide data from a longer period of time or to perform tests with a conservatively estimated high water level of 1.75 m.

3 Test program

Based on the previous section a program for the wave tank tests is proposed below. The programme has been designed to ensure that data is available to allow a good estimation of the surface loads corresponding to the design 100 years wave event. As it can be seen it is suggested to perform tests with a number of target wave conditions and not only exactly the 100 years wave event. This is done in order to allow comparisons of the laboratory data to measured data from the pilot plant once it has been build, also if the unlikely 100 years event does not occur during the prototype testing.

It is furthermore suggested that the tests are carried out with head-on and oblique waves, with various levels of directional spreading of the waves.

The test program is showed in table 5 on the next page.

In the column “Direction” the words “Front” and “Side” appear. “Front” means waves attacking head-on on the front of the structure – directly from West (270°). “Side” means waves rolling in on the side of structure – from North-West (315°). In all tests a JONSWAP spectrum with a peak enhancement factor of 3.3 is used.

Due to a limitation in model size, two pressure cell configurations are needed. Therefore, the used wave signals are stored and reused from configuration number one to configuration number two. Each of the 32 tests is thereby made twice. The duration of each test is 1800 s in model scale, corresponding to ~1.000 waves.

As the testing progresses the obtained results might show a need for adding a limited number of tests, and/or show that some of the planned tests are obsolete.

Test no.	H_s [m]	T_p [s]	Water level [m]	Direction	Wave field	n
1	7.5	12	30	Front	2D	
2	10.0	14	30	Front	2D	
3	12.5	15	30	Front	2D	
4	15.0	16	30	Front	2D	
5	2.5	8	30	Side	2D	
6	5.0	10	30	Side	2D	
7	7.5	12	30	Side	2D	
8	10.0	14	30	Side	2D	
9	7.5	12	31.75	Front	2D	
10	10.0	14	31.75	Front	2D	
11	12.5	15	31.75	Front	2D	
12	15.0	16	31.75	Front	2D	
13	2.5	8	31.75	Side	2D	
14	5.0	10	31.75	Side	2D	
15	7.5	12	31.75	Side	2D	
16	10.0	14	31.75	Side	2D	
17	7.5	12	31.75	Front	3D	4
18	10.0	14	31.75	Front	3D	4
19	12.5	15	31.75	Front	3D	4
20	15.0	16	31.75	Front	3D	4
21	2.5	8	31.75	Side	3D	4
22	5.0	10	31.75	Side	3D	4
23	7.5	12	31.75	Side	3D	4
24	10.0	14	31.75	Side	3D	4
25	7.5	12	31.75	Front	3D	10
26	10.0	14	31.75	Front	3D	10
27	12.5	15	31.75	Front	3D	10
28	15.0	16	31.75	Front	3D	10
29	2.5	8	31.75	Side	3D	10
30	5.0	10	31.75	Side	3D	10
31	7.5	12	31.75	Side	3D	10
32	10.0	14	31.75	Side	3D	10

Table 5. Proposed test program.

4 Model test setup

The model is made in scale 1:60. The tests are taking place in a wave basin with the dimensions 15.7×8.5 , maximum water depth ~ 0.70 m.

4.1 Description of bathymetry

In rough the bathymetry near the test site is as sketched on figure 5.

- Offshore water depth of +100 m.
- 300 m plateau.
- 30 m water depth locally.
- 1:1 slope directly in front of the SSG unit.

The bathymetry of the plateau is approximated as a horizontal seabed with a water depth of 30 m. The bathymetry in the immediate proximity of the pilot plant has been surveyed and the results here of has been presented in 3D drawing by WE. These data are shown in figure 6 and are used as the basis for the laboratory model.

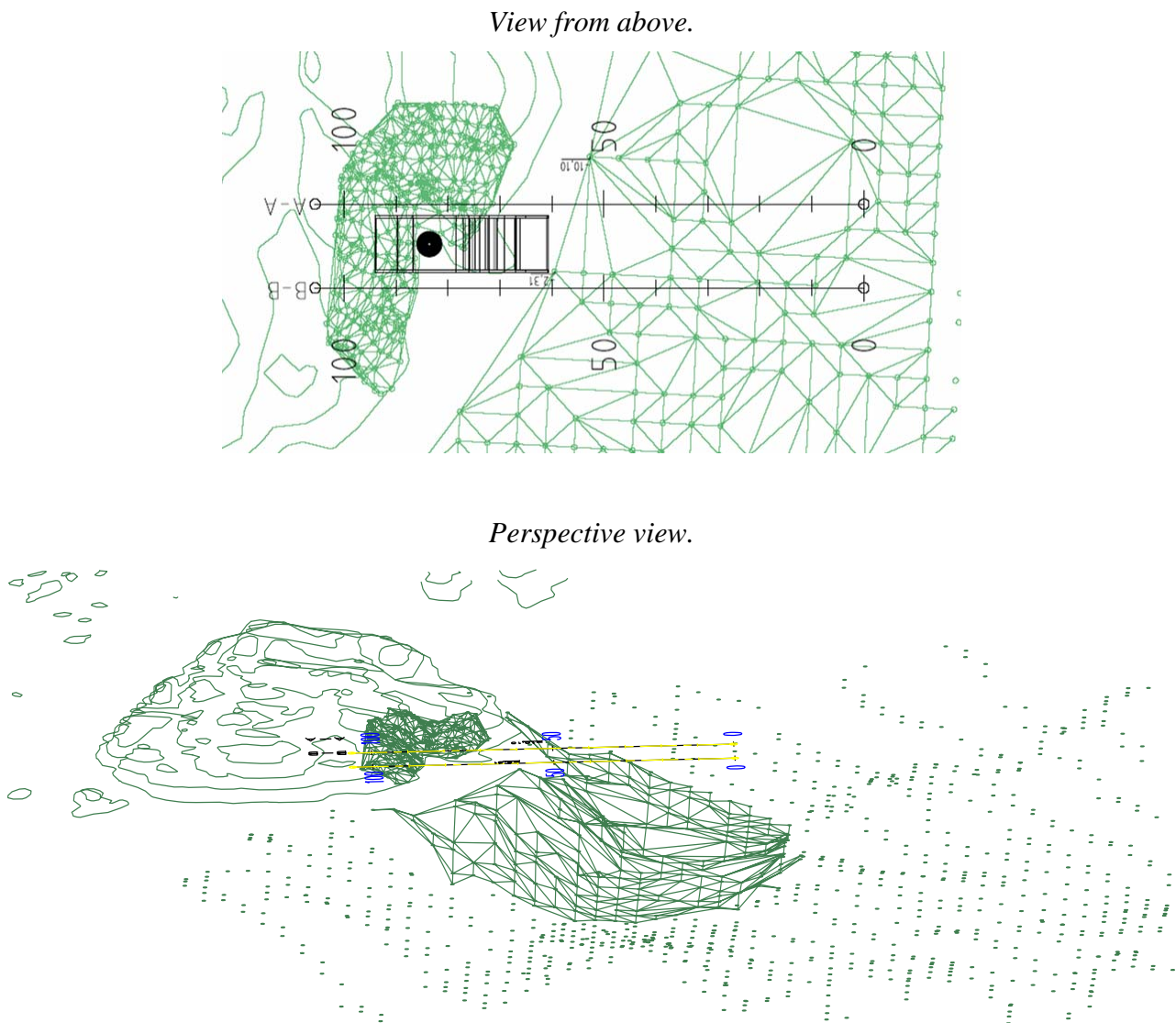

Figure 7. 3D drawing of local bathymetry.

Outside the plateau the water depth is modeled as 39 m. 146.4 m of the 300 m plateau is being build. A piece of 70 × 100 m of the cliff that the SSG is located on is being sculpted as described in the following.

4.2 Build-up of the model

The setup is made in scale 1:60. A 3D model of the cliff at the SSG pilot plant location is build in concrete. The model of the cliff is 1169 × 1670 mm and the heights are as listed below in mm:

e	f	g	h	i	j	k	l	
150	182	225	373	400	473	525	633	15
150	197	283	375	508	567	583	632	14
150	217	248	442	538	585	608	650	13
150	203	382	502	603	625	642	683	12
150	275	395	547	608	625	642	650	11
150	348	422	572	642	650	650	650	10
150	257	402	517	617	633	650	718	9
150	282	395	512	652	707	673	733	8
150	248	400	617	692	728	707	775	7
150	302	353	547	692	733	733	775	6
150	350	365	542	667	733	733	733	5

Table 6. Heights above wave tank floor.

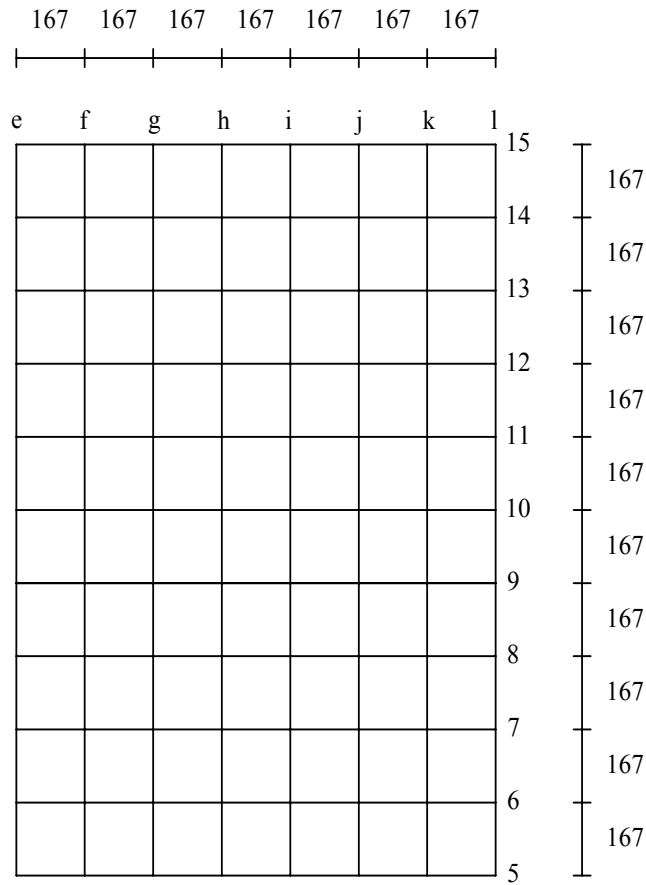

Figure 8. Grid seen from above. All measures in mm.

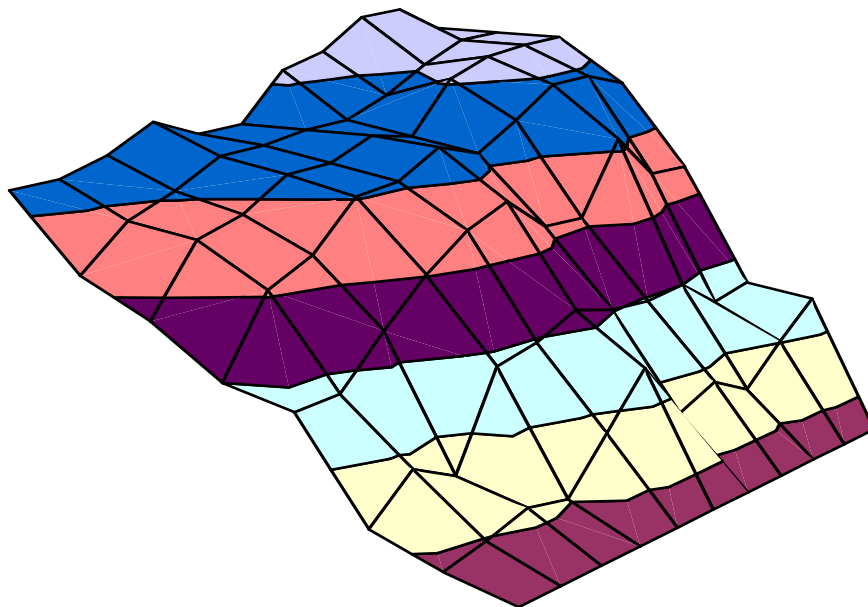
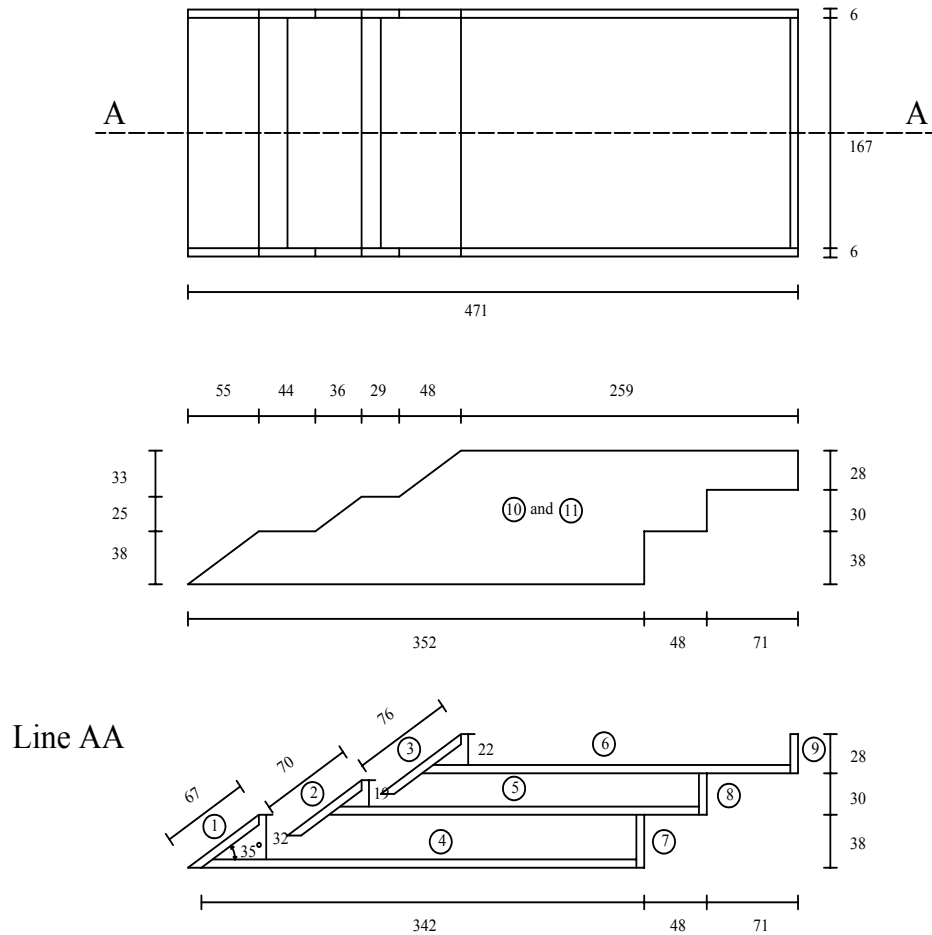
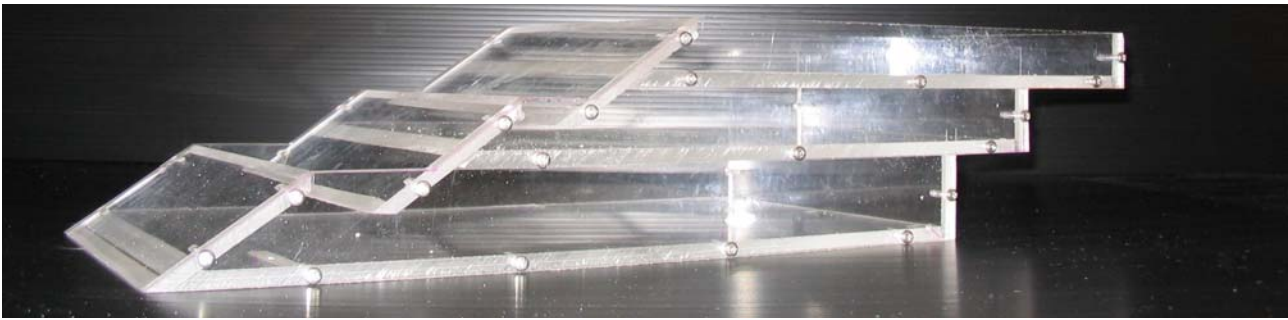

Figure 9. 3D model of the grid. (Combination of table 6 and figure 8).

The 1:60 model of the SSG unit is made of clear plexiglass, see figure 10. All plates are 6 mm thick.



Thickness of plates:

All measures are in mm.

All plates are 6 mm

Element sizes:

1. 67 * 167
2. 70 * 167
3. 76 * 167
4. 336 * 167
5. 284 * 167
6. 284 * 167
7. 38 * 167
8. 30 * 167
9. 28 * 167
10. 471 * 96
11. 471 * 96

Figure 10. Picture and drawing of model.

The model is crafted by technician Kurt S. Sørensen and checked by Brian J. Larsen. The entire setup with SSG unit, cliff and plateau placed inside the wave tank is shown in figure 10.

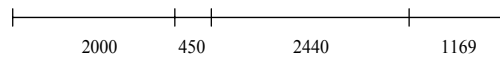
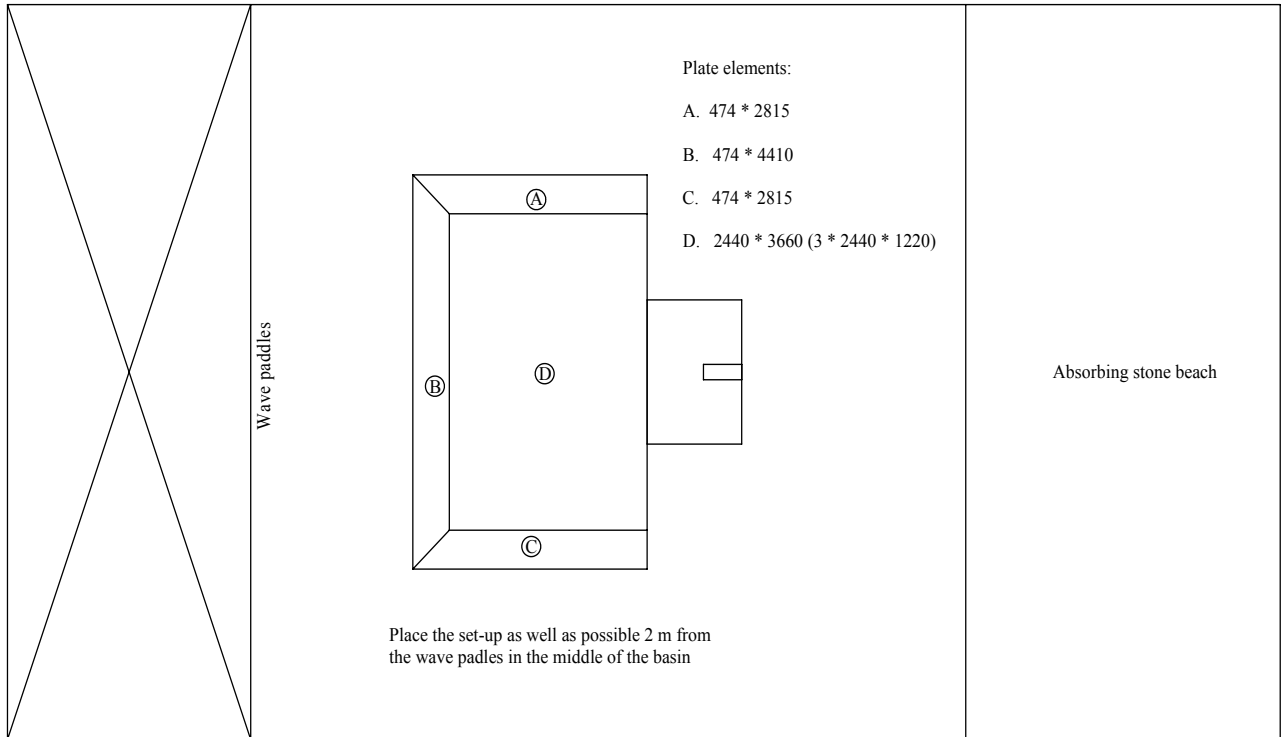

All measures are in mm

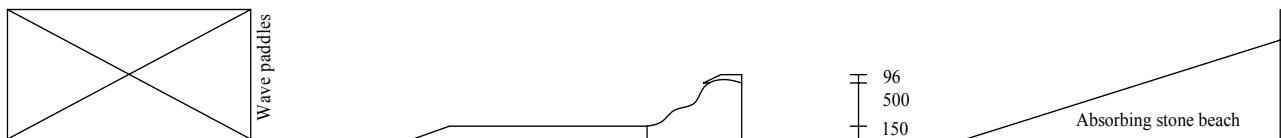

Figure 11. Drawing of set-up.

The three slopes between the plateau and wave tank floor are 1:3.

The set-up is made by technicians Kurt S. Sørensen, Jørgen S. Sørensen and Niels Drustrup and checked by Brian J. Larsen.

4.3 Wave generation

The waves are generated with 10 snake-type wave paddles driven by hydraulic pistons placed in one end of the wave tank. In the other end of the basin there is an absorbing stone beach. The wave machines are controlled by the wave generation software package AWASYS 5. AWASYS 5 is developed by AAU.

4.4 Instrumentation

The pressure is measured in a total of 25 positions on the SSG unit. The rather small model scale 1:60 results in a model of the structure with very limited space inside which – because of the physical dimensions of the pressure transducers – means that two different configurations are needed.

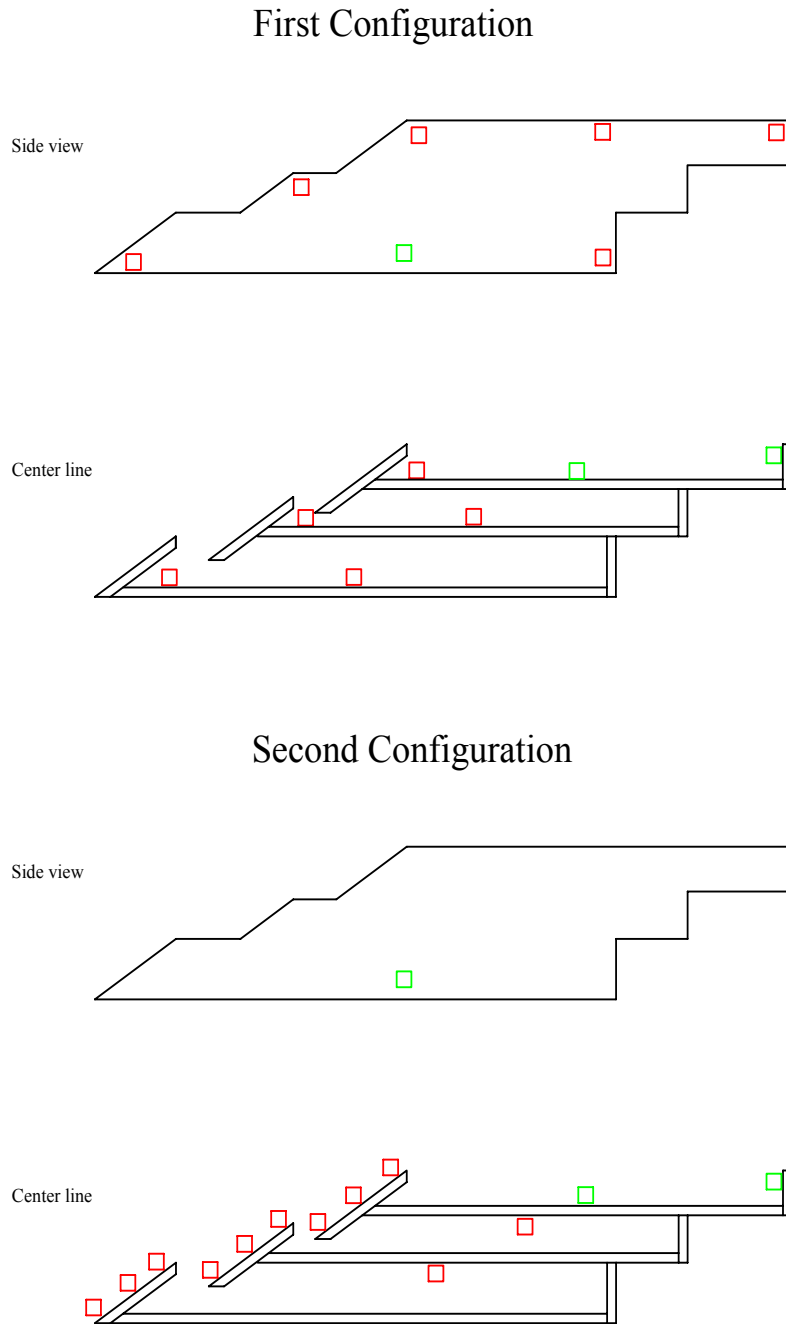

Figure 12. The approximate position of the 14 pressure cells are marked with red and green. The three marked with green are not moved from one configuration to another. They are used to compare the results from the two configurations.

Kulite Semiconductor pressure cells are used to measure the pressure on the SSG. The rated pressure of the cells is 1 bar and the maximum pressure is 2 bar. The sensitivity ranges from 74.249 mV/bar to 84.179 mV/bar.



Figure 13. Kulite Semiconductor pressure cell.

The transducers have been calibrated by the factory (see certificate example, figure 14) and the calibration parameters are checked prior to the model tests.



 	
CALIBRATION CERTIFICATE	
Model No: HKM-134-375M-1BARVG	Serial No: 6481-2-463
Customer: KULITE BENELUX/NORIS	P.O.: 1010043
STANDARD ELECTRICAL CONNECTIONS: X	SPECIAL CONNECTIONS:
RED +Input GREEN +Output BLACK -Input WHITE -Output	
TEST CONDITIONS:	
Rated pressure: 1 BAR VG	Operational Mode: VENTED GAGE
Maximum Pressure: 2 BAR VG	
Maximum Reference Pressure: N.A.	
Tested At: 10.00 VDC Excitation	Maximum Excitation: 15.00 VDC
CALIBRATION	
Sensitivity: 74.709mV/BAR VG	
Zero Pressure Output: <+/- 3% FSO	
Compensated Temperature Range: 5 DEG.C to 25 DEG.C	
Output Impedance: 1578 Ohms	Input Impedance: 2179 Ohms
NO SCREEN	
CABLE LENGTH: 7 METER	
'O' RING SUPPLIED	
M10X1	
REMARKS:	
QUALITY ASSURANCE: calibration traceable to NIST	
Pressure Source Id#: T022	Model#: RK-100
Traceable to NIST Report #: 251820-93	
Tested by: V. VASILCHIKOV	Inspected by: 
Date: 07/20/2001	Date: JUL 20 2001
The calibration of Kulite Semiconductor Products, Inc. Instrumentation is in conformance with MIL-STD-45662A	
<small>KULITE SEMICONDUCTOR PRODUCTS, INC. • One Willow Tree Road • Lodi, New Jersey 07635 • Tel: 201-461-0900 • Fax: 201-461-0990 • http://www.kulite.com UNITED KINGDOM • KULITE SENSORS LTD • Kulite House, Oxley Road, Kingsmead Business Park, Birmingham, B36 5UG England • Tel: 0181 618481 • Fax: 0181 618481 • Email: kulite@kulite.com GERMANY • KULITE SEMICONDUCTOR, GmbH • Postfach 1927 • D-68770 Hufarenz, Germany • Tel: 49 622 26500 • Fax: 49 622 26501 • http://www.kulite.de FRANCE • KULITE INTERNATIONAL SARL • 110, Boulevard de Strasbourg, 93100 St-Denis, France • Tel: 472632277 • Fax: 472632269 • Email: kulite@kulite.fr THE NETHERLANDS • KULITE BENELUX B.V. • Postbox 21 • 3280 AA Leerschenhoek, The Netherlands • Tel: 30217522 • Fax: 70372976 • Email: kulite@kucon.nl</small>	

Figure 14. Calibration certificate for Kulite Semiconductor pressure cell.

The waves are measured in a 7 point CERC wave gauge array placed on the plateau.

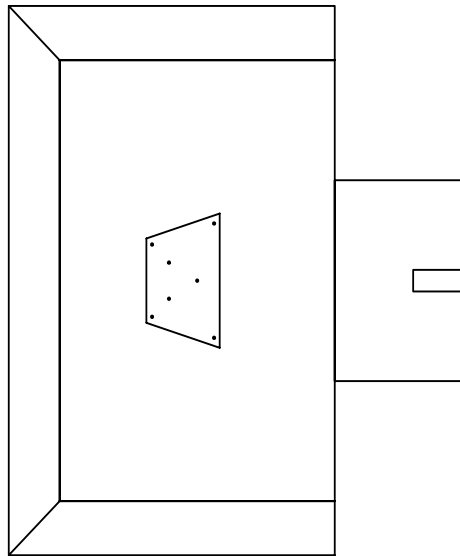

Figure 15. Position of wave gauges.

4.4.1 Calibration

All pressure cells are calibrated before they are mounted on the model. Water columns of three different heights are used as loads. After the pressure cells have been mounted their functionality is double checked.

All wave gauges were calibrated daily. The sensitivity ranges around 0.06 m/volt. The accuracy of the given wave heights are estimated to be ± 0.002 m in model scale.

4.5 Data acquisition and analysis

The signals from the pressure cells are sent to a MGC-plus device and sampled with Catman. The post processing of pressure data is done using custom made routines and results in average and extreme surface loads on the structure.

The wave signals are sampled and analysed with WaveLab 2. WaveLab 2 is developed by AAU. 2D reflection analysis are performed using the Mansard and Funke method. For the 3D wave analysis the BDM procedure in WaveLab 2 is used.

5 Summary

For head-on waves the 100 year event at the plateau can be given by wave condition $H_s = 12.5$ m and $T_p = 15.2$ s, based on the Statoil Refraction Analysis. The largest possible wave height is 24 m. Waves from a 100 year event at the plateau hitting the SSG unit on the side can be expected to have a H_s up to 5.5 m.

The structure is tested using both 2D and 3D waves with an angle of attack of both 0° and 45° . Waves between $H_s = 2.5$ m, $T_p = 8$ s and $H_s = 15$ m, $T_p = 16$ s are tested and both normal water level and 1.75 m high water level is tested.

The model tests are performed using a length scale of 1:60.

The wave induced pressures on the SSG unit are measured in 25 different points.

6 References

NORSOK Standard, "Action and Action Effects", p. 18, N-003, Rev. 1, Feb. 1999

Statoil, "Refraction Analysis – Boknafjorden", Sep. 2002

Hindcast Wave Data from Grid Point 1261 and 1262, DNMI, provided by WE

Tide data, Stavanger, 2000, provided by WE

Kofoed, J. P. (2005): *Model testing of the wave energy converter Seawave Slot-Cone Generator*. Hydraulics and Coastal Engineering No. 18, ISSN: 1603-9874, Dept. of Civil Eng., Aalborg University, April, 2005.

Kofoed, J. P. and Guinot, F. (2005): *Study of Wave Conditions at Kvitsøy Prototype Location of Seawave Slot-Cone Generator*. Hydraulics and Coastal Engineering No. 25, ISSN: 1603-9874, Dept. of Civil Eng., Aalborg University, June, 2005.

Kofoed J. P. (2002): *Wave Overtopping of Marine Structures – Utilization of Wave Energy*. Ph. D. Thesis, defended January 17, 2003 at Aalborg University. Hydraulics & Coastal Engineering Laboratory, Department of Civil Engineering, Aalborg University, December, 2002.