

Wireless Sensor Networking in the Construction Industry - Prospects and Problems

DOMDOUZIS, Konstantinos <<http://orcid.org/0000-0003-3679-3527>>, ANUMBA, C.J. and THORPE, A.

Available from Sheffield Hallam University Research Archive (SHURA) at:

<http://shura.shu.ac.uk/33243/>

This document is the author deposited version. You are advised to consult the publisher's version if you wish to cite from it.

Published version

DOMDOUZIS, Konstantinos, ANUMBA, C.J. and THORPE, A. (2004). Wireless Sensor Networking in the Construction Industry - Prospects and Problems. In: KHOSROSHAHI, F., (ed.) Proceedings 20th Annual ARCOM Conference. ARCOM, 1107-1120.

Copyright and re-use policy

See <http://shura.shu.ac.uk/information.html>

WIRELESS SENSOR NETWORKING IN THE CONSTRUCTION INDUSTRY - PROSPECTS AND PROBLEMS

Konstantinos Domdouzis, Chimay Anumba and Antony Thorpe

*Centre for Innovative Construction Engineering, Department of Civil & Building Engineering,
Loughborough University, Loughborough, LE11 3TU, UK*

Recent advances in wireless communications and VLSI technology have enabled the development of Wireless Sensor Networks in many scientific and technical fields. This paper is concerned with the wireless sensor networking applications in the construction industry. It reviews the key features of the technology, emerging construction applications and barriers to the uptake of the technology. In particular the paper describes many applications which show how useful the Wireless Sensor Networking technology can be. The benefits which are produced by the use of Wireless Sensor Networks on the construction site are also discussed. The relative novelty of Wireless Sensor Networking has given rise to a number of barriers related to their implementation. These barriers are often related to the cost of deployment of a Wireless Sensor Network as well as how reliable it can be. In contrast, there are also enablers, such as the Egan Report, which encourage the use of this new technology in the construction site. The paper concludes that the use of Wireless Sensor Networks in the Construction Industry will produce a number of innovative results and help the industry to improve its business processes.

Keywords : Applications, Barriers, Enablers, Sensors, Wireless.

INTRODUCTION

Wireless Sensors are small devices which are capable of performing a sensing task [Park et al., 2000]. A Wireless Sensor Network is a network of such devices capable of a cooperated sensing task. There are different categories of sensors, such as fibre-optic, photoelectric, radio-frequency identification, chemical, and acoustic. There is a growing interest in the construction industry for this new technology which can be explained by a number of reasons. For example, the deployment of wireless sensor networks enables the integration of a number of tasks related to the construction process. A wireless sensor network can contain a group of sensor nodes. Part of this group can be used for the monitoring of the equipment which is used on the site while another part of sensor nodes can be used for the recording of the humidity levels in the construction. In addition, the use of wireless sensor networks do not make necessary for the construction workers to access unsafe areas of the construction site.

A wireless sensor network includes a central station and one or more remote stations. The central station gathers the sensor network data, stores and distributes them to a number of users. The central station uses identification tables for the remote stations and develops an archive of sensor-related data and remote station-based information. It also contains software algorithms capable of supporting data polling operations and troubleshooting capabilities [URL2, 2003].

The architecture of the remote station is based on a number of modules which depends on the specified application. A module consists of a radio-frequency transceiver and a dedicated micro-controller. Connector interfaces are used for all modules for reasons of compatibility and data connectivity [URL2, 2003].

There is also the addition of a second module (analogue module) which provides sensor interface capability. A third module is used in order to provide power management functions to the remote stations. This module provides monitoring of the condition of the battery, a number of algorithms capable of controlling “power on/off” cycles for all other modules. A fourth module is responsible for the provision of embedded knowledge capability to the remote station. Specifically, this module is capable of performing mathematical functions and statistical analysis. It is specific for each application [URL2, 2003].

The function of each module is based on the use of embedded software algorithms. The most characteristic of these algorithms is the “Lost Station” software algorithm which is used by the Radio-Frequency Core module. This algorithm is based on a number of steps. Firstly, the network starts by using a master/remote protocol. The second step is the detection of a communication failure between the Central Station and a Remote Station. In this case, the central station commands the remote stations in order to locate and communicate with the central station. The next step is the establishment of communication between the assigned Remote Station and the “Lost Station” on a secondary established frequency. There is exchange of information between the Central Station and the “Lost Station” through the assigned Remote Station [URL2, 2003].

The possible topologies upon which the design of a wireless sensor network can be based are the following :

- *Point-to-Point Networks* : These types of networks are characterised by reliability because there is only one point of failure in the topology. This point is the host. The system can be improved by the addition of redundant hosts, however, the wiring of two hosts can be a problem. The 4-20 mA standard allows the operation of a number of read-out circuits if each read-out uses the standard loads. Problems can occur if read-out devices load the circuit beyond its capability. In this case, overloading is caused and there may be termination of the operation of the circuit. This possibility is known to the designers of the sensor networks [URL1, 2000].

A schematic representation of a point-to-point network is shown below:

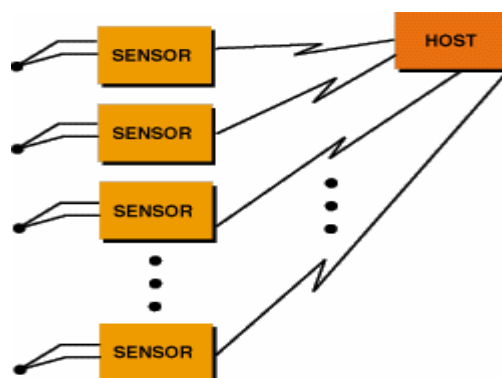

Fig.2 A point-to-point topology of a wireless sensor network [URL1, 2000]

In the above topology, each sensor node requires a separate twisted shielded-pair wire connection. In this case, the cost is high, the management of the network is difficult, while the host is responsible for the information processing [URL3, 2000].

- **Multi-drop Networks :** Multi-drop networks began to appear in the late 70s and early 80s. Examples of such networks are Modbus from Modicon, the Manufacturing Automation Protocol, Qbus and the VME Bus [URL1, 2000].

Multi-drop networks decreased the number of wires required for the connection of field devices to the host. The reduction of wires enabled the development of more complicated designs [URL1, 2000].

A schematic representation of a multi-drop network is shown below:

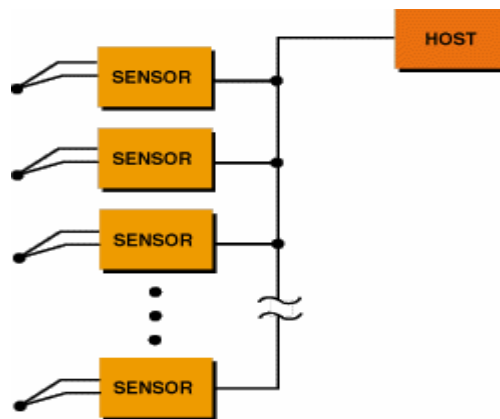

Fig. 3 A multi-drop wireless sensor network [URL1, 2000]

In the above topology, each sensor node places its information in a common medium. However, this requires attention to protocols in hardware and software [URL1, 2000]. The use of multi-drop buses caused digitisation problems. In point-to-point topologies, digitisation occurred in the host in which a single clock would be used for time-stamping when there was acquisition of analogue signals from multiple sensors. In multi-drop networks, the synchronization of clocks is a critical issue in a number of applications. This is an important issue in the design of a distributed system [URL1, 2000].

- **Web Topology :** In the web topology, all the nodes are connected to each other. Connectivity between nodes becomes complicated since each node needs to connect to all the other nodes. In this case, the use of repeaters and routers for the elimination of some A schematic representation of a Web topology is shown below:

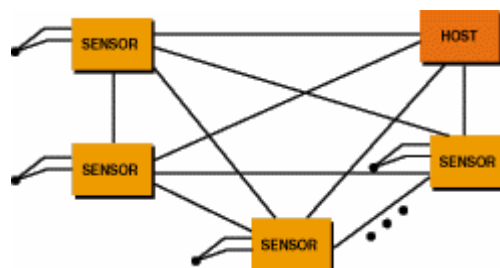

Fig. 4 Web topology of a wireless sensor network [URL1, 2000]

This paper introduces the key features of the Wireless Sensor Networking Technology and its applications to a variety of industries with specific emphasis to the Construction Industry. It also presents the enablers for the use of the technology, a number of barriers to it and the benefits of its use in the Construction Field.

APPLICATIONS OF WSN TECHNOLOGY IN OTHER INDUSTRIES

Wireless Sensor Networks are implemented in a variety of fields, such as medicine, chemical engineering technology and mechanical engineering. The applications of Wireless Sensor Networks in a number of industries are listed below :

Development of Micro-electromechanical Systems (MEMS)

Micro-electromechanical systems (MEMS) are the systems which combine miniaturised mechanical and electronic components. They are successfully implemented in biotechnology and communications [Soloman, 1999]. In the biotechnology field, MEMS technology has been used in the identification and amplification of DNA as well as the development of microscopes, drug screening and hazardous agents detection [URL6, 2002]. In the field of communications, MEMS technology has enabled the development of Radio-Frequency-MEMS system-in-a-package (RF-MEMS-SiP) modules through the integration of MEMS devices with Application-Specific Integrated Circuits (ASICs). These modules are characterised by reduced energy consumption and improved performance [URL4, 2003].

Pharmaceutical Industry

In the pharmaceutical industry, sensors can be used in the monitoring of the packaging environment of the medicines. Such a system consists of elements, such as a scanning system for the examination of the pharmaceutical products, a climate sensor for the monitoring of their temperatures, a digital bottle cap torque sensor for the testing of whether the torque of bottle caps have been removed or not and thermo-hygrometric sensors for the measurements of the temperature in the pharmaceutical environment [URL7, 2002]. Thermally resistive sensors are also used for the creation and maintenance of the temperature within the environment of production of medicines [URL8, 2003].

Chemical Industry

In the chemical industry, wireless sensor networks are used in the discovery of chemical leaks. An example of a chemical leak detection system is the system which was developed by Crossbow Technology and Cyrano Sciences, Inc. The specific system is able to collect data from chemical and pharmaceutical labs. These data take the form of digital signals which can be analysed by pattern matching and data mining algorithms [URL9, 2003].

Food Industry

Wireless sensor networks can be used in the food industry for monitoring of the conditions of food packaging as well as of the tools used for this procedure. An interesting application is the sensor-based Multi-blade Knife Failure Detector (KFD) which was developed by Lamb-Weston, Inc. and the Pacific Northwest National Laboratory (PNNL). This system is able to detect damages in the blades used for shaping potatoes before they are packed. KFD uses a controller, an acoustic sensor and a wireless base station which is connected to a control unit. When there is

detection of the damaged blade by the sensor, there is transfer of the signal to the control unit. The unit enables the plant control centre to initiate the replacement of the damaged blade [URL10, 2000].

Computer-Integrated Manufacturing (CIM)

Sensors and control systems in manufacturing are very useful tools for the implementation of Computer-Integrated Manufacturing (CIM). The most important CIM system components are numerical control machines and an automated material handling network capable of transporting the product from raw material inventory, through the numerical control operations and finally to the finished goods inventory. During the manufacturing process, sensors are used in the assembly of the product, provision of specific commands to any robots used in the manufacturing process and the programming of automated guided vehicles [URL11, 2003].

Medical/Biomedical Engineering Industry

Health-related applications include tracking and monitoring of doctors and patients inside a hospital. Other applications include monitoring of the level of glucose, cancer detection and general health monitoring [Xu, 2003]. Artificial Intelligence and Image Processing techniques are implemented for the realisation of these applications. Research is also being undertaken in the field of breast cancer detection in order for mammographic techniques to be improved through the use of sensors [URL12, 1996]. Sensors can be used also in order to protect an area of the hospital from the existence of any germs or bacteria. The detection of bacteria can be achieved electro-chemically by sensors [URL13, 2003]. Furthermore, wireless sensor networks can be used in homes for the monitoring of the condition of old people or people with chronic diseases or disabilities. A number of techniques, such as pattern recognition and data mining are used in this case [URL14, 2003].

Precision Manufacturing Applications

A comprehensive detection system for automated manufacturing equipment must be considered as part of the manufacturing strategy. A major element necessary to develop an intelligent automatic manufacturing system is the concurrent development of automated diagnostic systems, with a network of sensors to include machinery maintenance and process control functions [Soloman, 1999]. Sensors can be used in a number of precision manufacturing applications, such as the accurate measurement of the width of a product and the detection of very small elements of a machine. This sensor uses a variety of sensing heads, the smallest of which can be connected to an amplifier unit. This unit is used to process the returned light. The amplifier unit can then generate digital and analogue outputs [URL15, 2003].

POTENTIAL APPLICATIONS OF THE WSN TECHNOLOGY IN CONSTRUCTIONS

Wireless Sensor Networks can be applied successfully to the construction industry. The current applications of Wireless Sensor Networks in the construction industry are listed below:

- *Construction of Safer Buildings* : Smart structures involve the use of sensors in order to specify the condition of the structure and detect any construction faults. So far, a number of conventional and fibre-optic sensors have been used in various structures. Embedded fibre-optic sensors may reveal the building's internal structural integrity. In addition, these sensors may be used in a remote place, thus allowing the structural health of the building to be checked remotely [Soloman, 1999].

- *Alerting the Owner of a House during Fire or Extreme Gas Emission* : Sensors can be used in order to alert the owner of a building when there is emission of a large amount of gas or if there is smoke. The detection of smoke can be done by the use of optical and ionisation detectors which are capable of sensing different gas particles. A signal-processing method is also used in order to distinguish situations of fire and non-fire. This distinction is based on the identification of fire signatures from measured sensor responses [Kanoun et al., 2001].
- *Alerting the Security Services during Intrusion Detection* : The detection of an intruder into the area of a house can be achieved by the use of specific identification systems, such as biometric systems, ID tags, finger-print sensors or speech-processing systems. A biometric system can hold in a database details related to the iris of the eyes of the residents of a house and compares them through a tiny camera with the iris of a person who comes to the entrance of the house and requests to enter. If the data are different, then the system considers this person as a non-resident of the house. Finger-print sensors and speech processing systems work in a similar way [Kanoun et al., 2001].
- *Monitoring the Living Conditions Inside the House* : Sensors can be used to check the quality of the air in the house and also to control the heating. If the heating or the quality of the indoor air are not appropriate , then the sensors can adjust the heating level or the ventilation. The assessment of the quality of the indoor air can be achieved by measurement of the amount of carbon dioxide while the assessment of the level of heating can be achieved by evaluating how warm the environment is in the house. Any increase in the electrical resistance of the sensor results in the detection of the levels of heat within the house [Kanoun et al., 2001].
- *Control of Lighting and Household Appliances* : In this case, sensors can be applied in order to provide the necessary lighting when the residents of a house need it. For example, if a resident enters a room of the house, then the sensors must detect him/her by using Pattern Recognition techniques and switch on the lights. When he/she exits the room, then the lights are switched off. Sensors can be applied in the same way in household appliances. Specifically, if someone in the house places food in the oven, then sensors must be able to detect the type of food and adjust the temperature appropriately.
- *Use of Medical Sensors in order to monitor the condition of elderly or disabled people* : Sensors can be applied in order to monitor the condition of elderly or disabled people and alert paramedics if something goes wrong. An example of the use of sensors for the monitoring of the condition of elderly people is the ring device which was developed at the Massachusetts Institute of Technology. This device is placed on the finger of the monitored person and through the use of a light-emitting diode (LED), it sends light into it. Some of this light is reflected back from the blood vessels and it is collected by a photodiode. The photodiode converts the light into an electrical signal which is elaborated by a tiny circuit. This circuit elaborates the signal by rejecting the existence of noise and transmits to a receiver placed at the house of the monitored person. The receiver sends the signal to a telemedicine centre in a hospital in order for the data to be analysed. The analysis of the data shows how normal the pulse rate of the monitored person is [URL3, 1997].

- *Damage Detection using the Structure Health Monitoring (SHM) System* : The Structure Health Monitoring (SHM) System is another important example of wireless sensor network applications. The scope of the SHM System is damage detection and estimation of its extent, damage localization and prediction of the life of the building. SHM is characterised by a number of advantages which are the following : low deployment and maintenance cost, large physical coverage as well as high spatial resolution [Xu, 2003].
- *Tracking of Items on the Construction Site* : Wireless Sensor Networks can be implemented for the purpose of tracking of items on the construction site and for gathering data, either for the purpose of monitoring the site or for reasons of item identification [Furlani et al., 2000]. In addition, they are able to provide security on the construction site, either by constantly monitoring the site or by alerting the engineers when an item has been stolen [URL4, 2003]. The monitoring of the construction site and the tracking of objects within it, can be achieved by the use of a technique called Radio-Frequency Identification (RFID). RFID uses smart tags that are small transponders which can be fitted to any equipment. The transponder includes a tiny computer chip which can store a specific amount of data. When the transponder is near a stationary smart tag sensor reader device, it broadcasts the data contained in the chip [URL4, 2002].

BARRIERS TO WIRELESS SENSOR NETWORKING TECHNOLOGY

There are several barriers which create doubts about the implementation of the Wireless Sensor Networking technology on the construction site. These barriers include the following:

- *Cost* : Wireless Sensor Networking technology is a relatively new technology and as a result there are many questions related to the cost of deployment and maintenance of a wireless sensor network on the construction site. The needs of a construction project will affect issues of deployment of the Wireless Sensor Networking Technology on the construction site. If the construction project requires the cooperation of many sites, then the topology of the Wireless Sensor Network as well as the number of the sensor nodes must be appropriate to the needs of the project.
- *Reliability* : Because Wireless Sensor Networking technology is relatively new, there are questions over its reliability as there may be failures when this technology is deployed on the construction site. Specifically, Wireless Sensor Networks are characterised by routing and coverage problems. Traditional routing techniques which are applied in wired and wireless communication networks are not implemented in Wireless Sensor Networks. Coverage issues in Wireless Sensor Networks are related to how well sensors observe their physical space. For example, the level of coverage of a sensor network may be different if a sensor agent changes its direction.
- *Lack of Knowledge* : The people who work in the construction site may not have the required knowledge in order to use a wireless sensor network. Wireless Sensor Networks are a very modern technology and as the literature shows, there are not many publications related to their applications in the construction industry. As a consequence, it becomes difficult for the construction industry to adopt a technology whose capabilities does not fully appreciate.

- *Fear of Employers for Lower Productivity and Higher Cost* : Employers do not want to take the risk of implementing a very new technology on the construction site because they may think that the possible lack of knowledge by the engineers of the details of the specific technology will result in lower productivity and loss of profit. The engineers may lose time trying to implement the Wireless Sensor Networking Technology on the construction site, thus interrupting the construction work. In this case, the progress rate of the construction work is reduced. In addition, the training of the workers for the specific technology may also be costly.

ENABLERS FOR WIRELESS SENSOR NETWORKING TECHNOLOGY

There are several enablers which forward the development of Wireless Sensor Networking Technology. These are the following:

- Egan Report/Latham Report : Sir John Egan and Sir Michael Latham both developed separate reports about the state of the UK construction industry. Both reports refer to the need for modernisation of the UK industry and this means that more attention should be given to research into new technologies and the training of the workforce on these technologies. Sir John Egan refers also to the need to use of integrated processes [Egan J., 1998].
- Economic, Social & Political Advances : The economic progress of several Western countries has enabled the investment of a large capital for research over the implementation of new technologies. Specific research institutes, such as the National Aeronautics and Space Administration (NASA), receive annually a large amount of funding in order to conduct research related to these technologies. Globalisation has also given the necessary boost for the development of technologies which attempt to distribute information worldwide without meeting any frontiers. This has as a consequence the creation of multiple research projects related to these technologies and a number of research groups which undertake research on new technologies. Wireless Sensor Networking Technology is the result of this continuous research.
- Need for Integration of the Processes realised on a Construction Site : Wireless Sensor Networking Technology is capable of monitoring the construction site, alerting workers if something goes wrong, eg. theft of an item or tracking an important item within the site. It can handle all these processes simultaneously and as a result it contributes significantly in the reduction of time loss and cost. Wireless Sensor Networks are able to collect and elaborate data quickly. In addition, they can assess a structure and produce a number of assumptions which can be useful to the engineer.
- Need for Security on the Construction Site : The deployment of the Wireless Sensor Networking Technology on the Construction Site enables better monitoring of the site, alerting the workers if there is danger on the construction, thus preventing accidents and also tracking lost or stolen items within the site. In this case, the cost which occurs because of the loss of items is decreased significantly.

BENEFITS OF WIRELESS SENSOR NETWORKING IN CONSTRUCTION

Wireless Sensor Networks offer a range of benefits in the construction field. These benefits are listed below:

- **Prevention of Serious Damage to Buildings:** Because of their ability to monitor the status of a building on a continuous basis, Wireless Sensor Networks can enhance its safety. This is because the data which are extracted by the monitoring of the status of a building, can be used in the examination of the level of attrition of the materials of the building, thus preventing any future serious damage.
- **Protection of Buildings against possible Earthquakes:** A Wireless Sensor Network can alert the engineer about the endurance of a building against an earthquake and in this case, a number of protective measures can be taken. The monitoring of the status of a construction or building can also decrease the possibility of an error being made by the engineer.
- **Reduction of Cost during the Construction Process:** Wireless Sensor Networks contribute significantly to the reduction of cost resulting from the loss of materials from the construction site due to theft. Wireless Sensor Networking Technology can guarantee the security of the construction site by providing constant monitoring.
- **Reduction of the Time needed for the Realisation of a Construction Project:** The integration of construction processes which is offered by the Wireless Sensor Networking Technology as well as the quick gathering of real-time data related to the construction project, enable a significant reduction of the time which is required for the realisation of the construction project. Wireless Sensor Networks are capable of monitoring the construction site, assessing the structure and checking the progress of the construction project and all these processes can be achieved in a small amount of time.
- **Improvement of the Work Conditions of the Construction Workers:** The foreman of a specific construction project can monitor the progress of the project by collecting real-time data using a computer. The computer can be connected to a Wireless Sensor Network which monitors the progress of the work. In this case, workers do not have to go themselves to assess the construction work and its different parameters, such as the quality of the materials used or the existence of any possible damages/defects.

CONCLUSIONS

Wireless Sensor Networking Technology is a field which is still at the research stage in the construction industry. It is characterised by a number of advantages, such as the quick handling of information and the integration of a number of processes, but also by a number of disadvantages, such as routing issues especially in large sensor networks. However, even in these cases, the introduction of a number of techniques, such as Dynamic Source Routing, has enabled the resolution of these issues. In general, the application of the Wireless Sensor Networking technology in the field of construction is expected to produce a number of benefits.

REFERENCES

- Sir Egan J (1998) Rethinking Construction. The Report of the Construction Task Force (Also available at : <http://www.rethinkingconstruction.org/documents/Rethinking%20Construction%20Report.pdf>)
- Furlani, K.M., Pfeffer, L.E. and Stone, W.C. (2000) Automated Part Tracking on the Construction Job Site. In: ASCE Conference on Robotics for Challenging, Environments, 2000, Albuquerque, N.M.

- Kanoun, O and Trankler, HR (2001) Sensor Systems in Intelligent Buildings. In: O. Gassmann and H. Meixner (eds.), Sensors in Intelligent Buildings. Weinheim: WILEY-VCH
- URL1 Manges, W, Wireless Sensor Network Topologies, Retrieved: September 13, 2003, from : <http://www.sensormag.com/articles/0500/72/main.shtml>
- Park, S, Savvides, A, Srivastava M.B. (2000) SensorSim: A Simulation Framework for Sensor Networks, Electrical Engineering Department, University of California Los Angeles, MSWiM 2000, Boston, (Also available at: <http://nesl.ee.ucla.edu/projects/sensorsim/papers/sensorsim.pdf>)
- Soloman, S (1999) Sensors Handbook. London: McGraw-Hill
- URL2 Perotti, J, Wireless Sensor Networks Approach, NASA Instrumentation Group Lead Kennedy Space Centre, Florida, Retrieved: September 19, 2003, from :http://www.nasatechnology.com/ndes_docs/KSC%20Wireless%20sensor.ppt
- URL3 Wheeler, M, (1997) Ring Monitors Homebound Patients, Retrieved: November 20, 2003, from: <http://www.photonics.com/spectra/tech/XQ/ASP/techid.115/QX/read.htm>
- URL4 MEMS for wireless communications: 'from RF-MEMS components to RF-MEMS-SiP' 2003, Retrieved: November 17, 2003, from : <http://www.iop.org/EJ/abstract/0960-1317/13/4/323/>
- URL5 Types of Temperature Sensors, Retrieved: December 16, 2003, from <http://www.temperatures.com/sensors.html>
- URL6 Silicon Lab-On-Chip for Integrated DNA Amplification and Detection 2002, Retrieved: November 17, 2003, from :<http://us.st.com/stonline/prodpres/dedicate/mems/technolo/fluidic/labonchip.htm>
- URL7 Product Update – Ensure High-Quality Sensors, Retrieved: October 15, 2003, from : <http://www.devicelink.com/pmpn/archive99/03/006.html>
- URL8 VERITEQ – Thermal Validation in the Pharmaceutical industry 2003, Retrieved: October 25, 2003, from : <http://www.veriteq.com/thermistor>
- URL9 Crossbow Technology and Cyrano Sciences to Develop Bluetooth Wireless Instrumentation to Find Chemical Leaks, Retrieved: October 22, 2003, from : <http://cyranosciences.com/company/crossbow.html>
- URL10 Multi-Blade Knife Failure Detector (KFD) for Food Processing, Retrieved: October 15, 2003, from : <http://www.technet.pnl.gov/sensors/macro/projects/images/es4acmon.pdf>
- URL11 CIM Lab – Courses 2003, Retrieved: November 18, 2003, from : http://www.ie.bgu.ac.il/cimsite/cim/cim_lab_courses.asp
- URL12 Antony Seibert 1996, Early Breast Cancer Detection with Fiberoptic-CMOS Detector, Retrieved: November 20, 2003, from: http://www.cbcrp.org/research/Pagegrant.asp?grant_id=126
- URL13 How sensors work, Retrieved: November 19, 2003, from: <http://www.sensorland.com/HowPage057.html>
- URL14 Research – Point-of-Care Biomedical Engineering 2003, Retrieved: October 23, 2003, from : <http://www.bme.ogi.edu/research/index.php?area=6>
- URL15 Omron Electronics 2003, Smart laser sensors answer precision sensing needs Retrieved: November 19, 2003, from: <http://www.manufacturingtalk.com/news/omr/omr111.html>

Xu, N A (2003) A Survey of Sensor Network Applications, Computer Science Department, University of Southern California, Los Angeles, California (Also available at: <http://enl.usc.edu/~ningxu/papers/survey.pdf>)