



Automated Deep Learning for Defect Detection in Carbon Fibre Reinforced Plastic Composites

Vedran Tunukovic^{1,2}, Shaun McKnight¹, Ehsan Mohseni¹, S. Gareth Pierce¹, Richard Pyle¹, Euan Duernberger¹, Charalampos Loukas¹, Randika K. W. Vithanage¹, David Lines¹, Gordon Dobie¹, Charles N. MacLeod¹, Sandy Cochran², Tom O'Hare³

¹Sensor Enabled Automation, Robotics, and Control Hub (SEARCH), University of Strathclyde, United Kingdom

²Future Ultrasonic Engineering, FUSE CDT, Glasgow, UK

³Spirit AeroSystems, Belfast, United Kingdom

vedran.tunukovic@strath.ac.uk

July 2023

ASME
QNDE 2023
Quantitative Nondestructive Evaluation



Introduction

- Carbon fibre composites are made of layers of materials stacked together for best strength to weight ratio
- This gives them a unique set of properties and makes them ideal for use in aerospace industry
- Such increase in use mandates a drive for a detailed post manufacturing evaluation

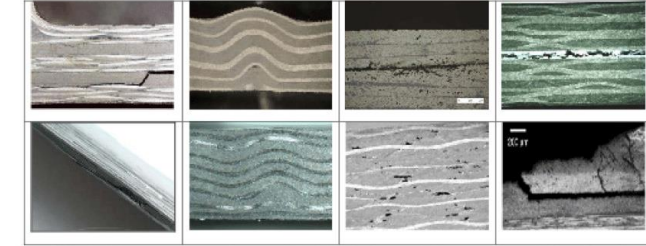

Examples of defects that can occur in Carbon Fibre Reinforced Polymers [3]

Structural percentage (mass) of composites in commercial aircraft [1,2]

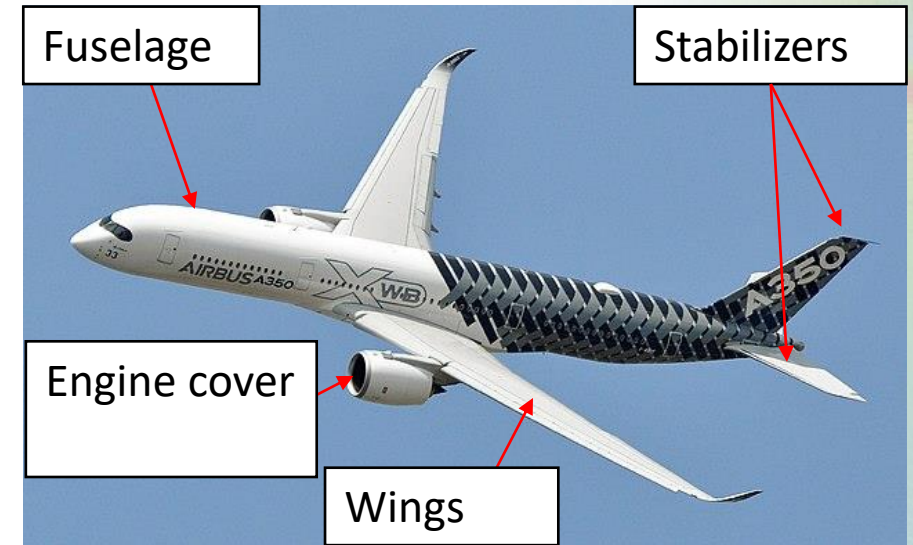
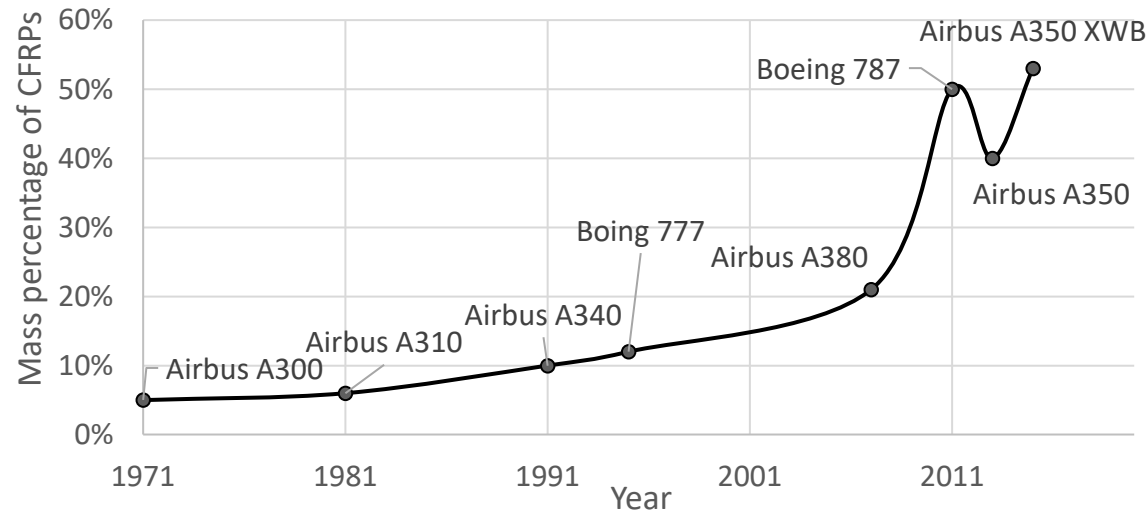

Photo by Eric Salard - F-WWCF A350 LBG SIAE 2015, CC BY-SA 2.0

[1] Younossi O, Kennedy M, Gräser JC. Military Airframe Costs The Effects of Advanced Materials and Manufacturing Processes [Internet]. 2001 [cited 2022 May 18]. 9 p. Available from: <http://www.rand.org/>
 [2] Slayton R, Spinardi G. Radical innovation in scaling up: Boeing's Dreamliner and the challenge of socio-technical transitions. Technovation. 2016 Jan 1;47:47–58.
 [3] Guemes et al., Structural Health Monitoring for Advanced Composite Structures: A Review, DOI: 10.3390/jcs4010013



Automated ultrasonic NDT inspection

- Use of industrial manipulators accelerated scanning, with greater precision and repeatability
- Setup in the SEARCH lab is based on KUKA KR90 industrial manipulator, with path programming being done in LabVIEW software and vertical movement controlled with Force Torque sensor

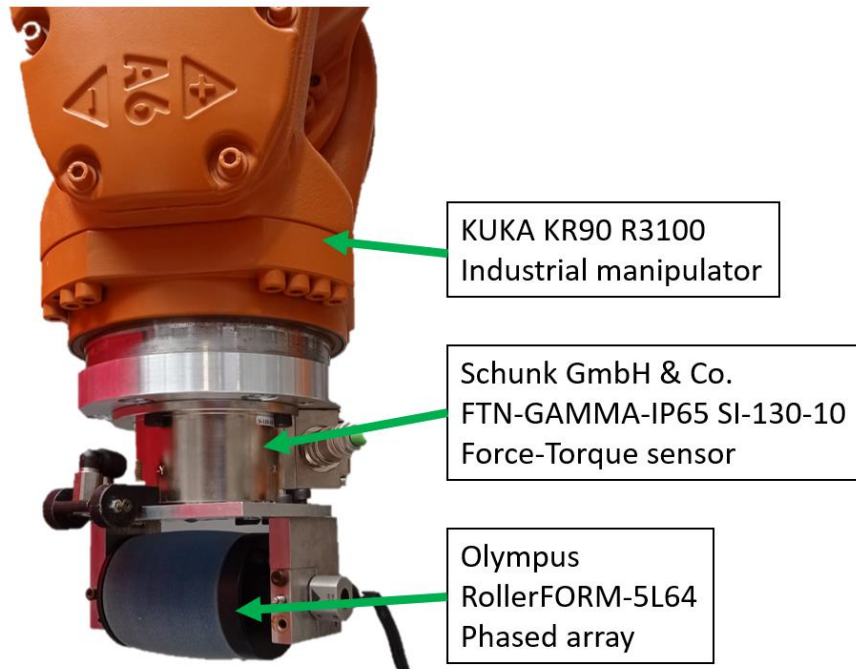

Automated ultrasonic NDT inspection

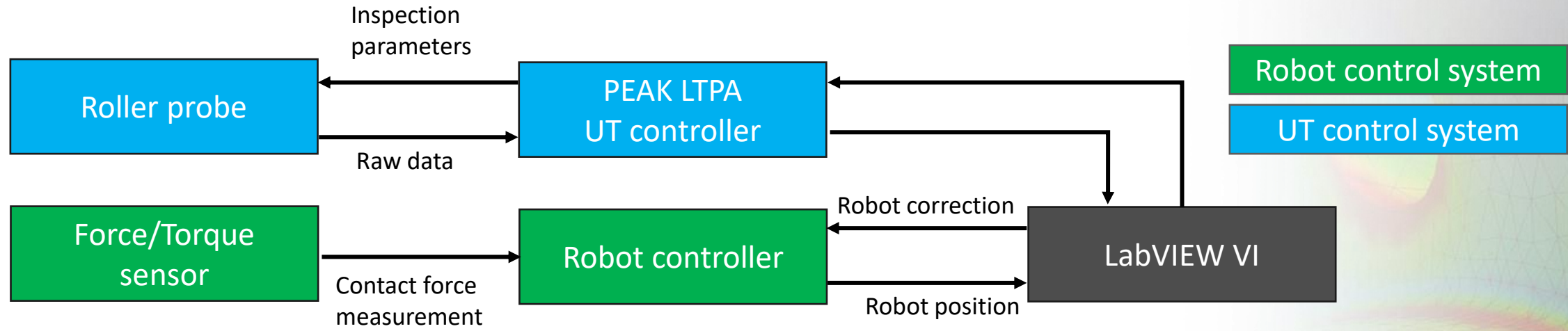

Equipment information

Roller probe	Olympus RollerFORM-5L64
Elements	64, 0.8 mm pitch
Ultrasonic controller	PEAK MicroPulse 6
Gain	20 dB
Pulse repetition frequency	760 Hz
Scanning speed	10mm/s
Operating frequency	5 MHz
Element sub-aperture	4 elements
Driving voltage	80 V

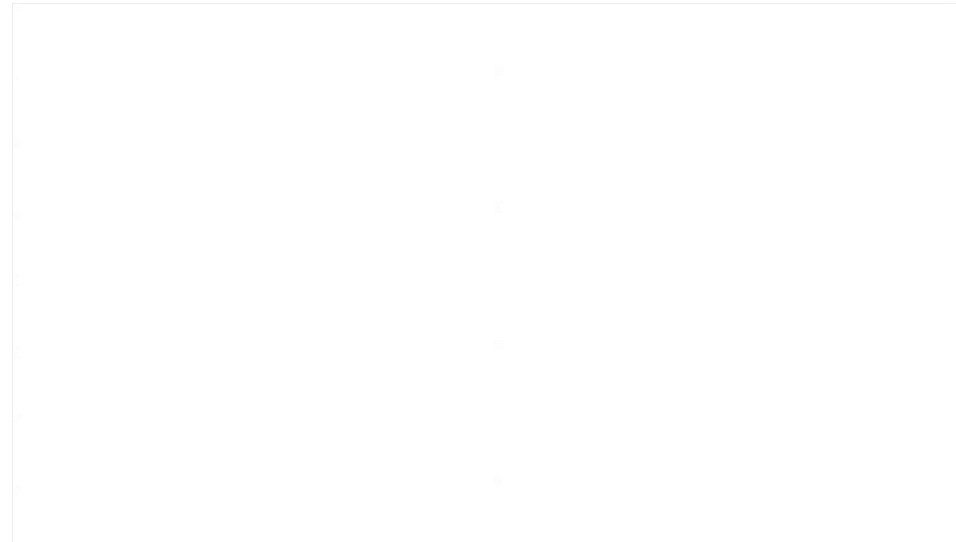

Demonstration
of ultrasonic
NDT inspection



Motivation for research

- Manual inspection is labour intensive and reliability is influenced by a human operator
- Automatic inspection needs little to no labour, and is precise and repeatable
- Data interpretation presents a bottleneck (6 – 8 hours to process data and generate a quality report)
- Research task: **Compare different methods for defect detection and localisation in ultrasonic C-scans of carbon fibre reinforced plastic samples with defects**

Overview of used samples

Sample	Dimensions	Thickness	Defects
A	254.0 x 254.0 mm	8.6 mm	15 FBHs and 2 delaminations
B	254.0 x 254.0 mm	8.6 mm	25 FBHs
C	780.0 x 200.0 mm	7.5 – 16.0 mm	12 Teflon and 12 bagging film inserts
D	300.0 x 90.0 mm	8.0 – 21.0 mm	14 Teflon inserts
E	254.0 x 254.0 mm	8.6 mm	N/A - Pristine sample

Embedded defects in range 3.0 – 9.0 mm

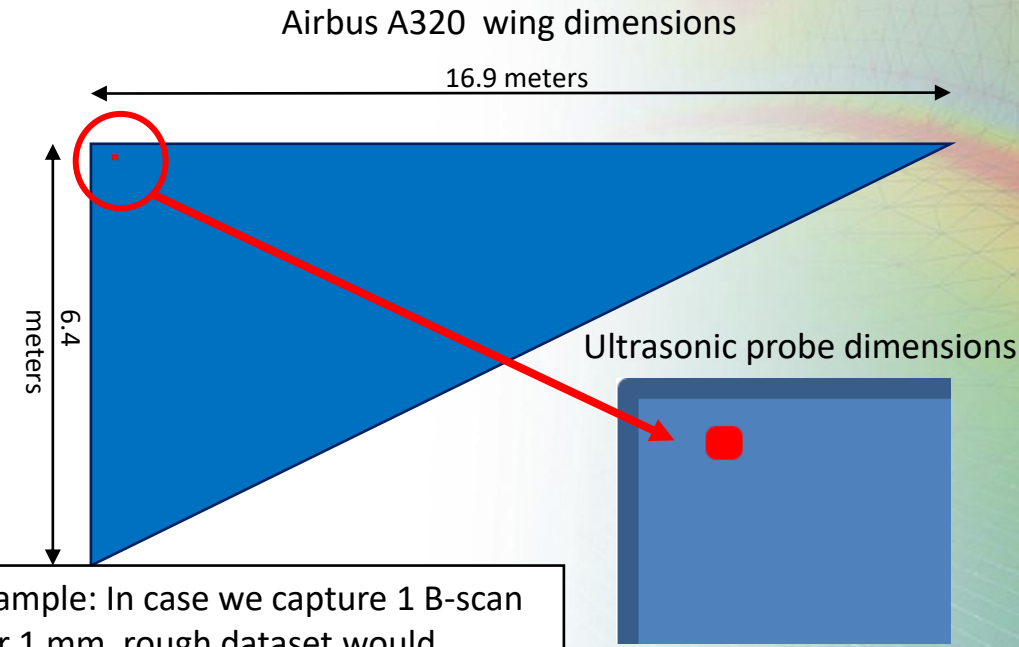

Example: In case we capture 1 B-scan per 1 mm, rough dataset would consist of 1.08 million B-scans



Overview of used methods

This work focuses on a comparative study between:

1. Amplitude thresholding
 - Implementation of 6 dB method
2. Statistical image thresholding
 - Based on statistical probability that pixel belongs to a defect class
3. Machine learning approach
 - Supervised approach trained on synthetic dataset



1. Amplitude thresholding

- Adaptation from 6 dB drop method used in defect sizing
- 6 dB drop physically refers to the decrease in the amplitude by half
- In generated C-scan, 6 dB drop is performed with respect to the maximum occurring amplitude

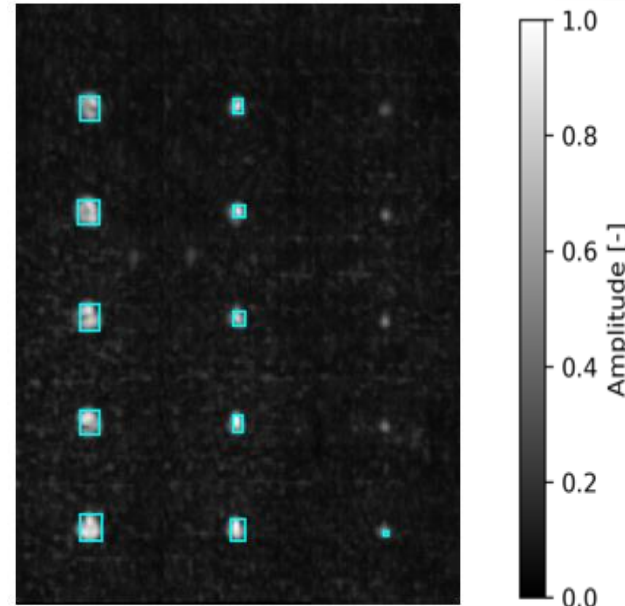
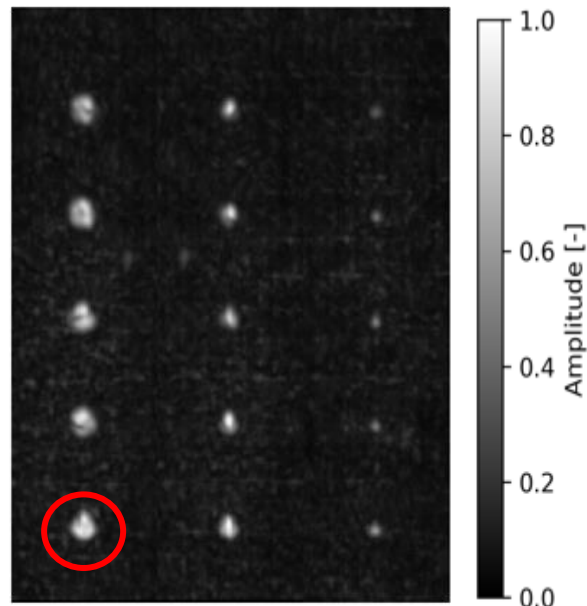

2. Statistical image thresholding

- Method based on work by Wilcox et al. [4] where no prior knowledge about defective areas is needed, if they are sufficiently different from background
- A healthy ultrasonic C-scan (or a section) is used to produce statistical distribution of pixel amplitudes

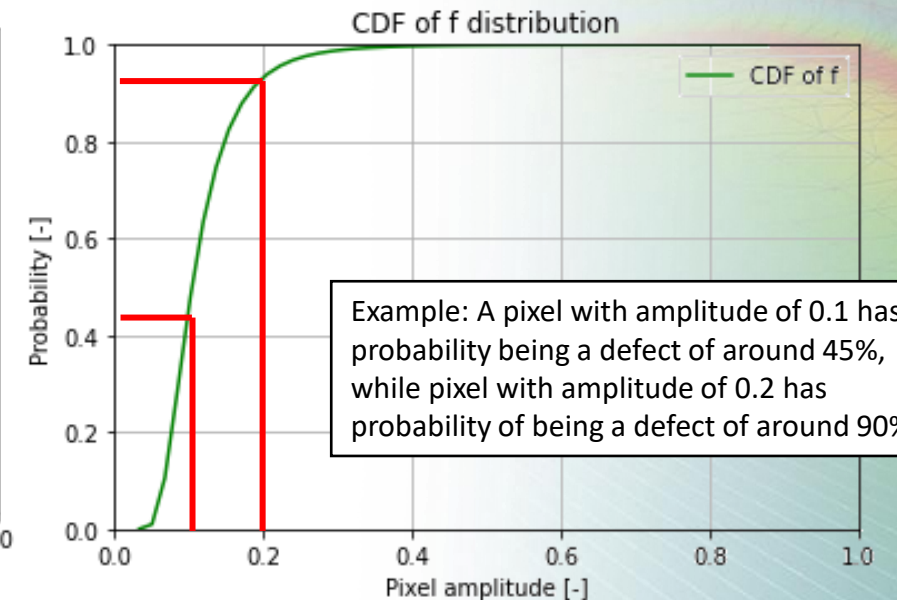
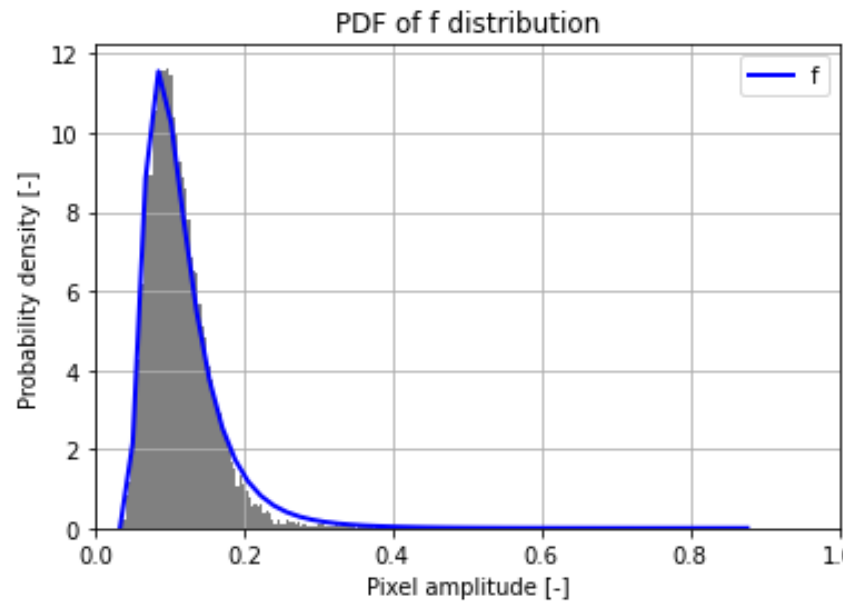
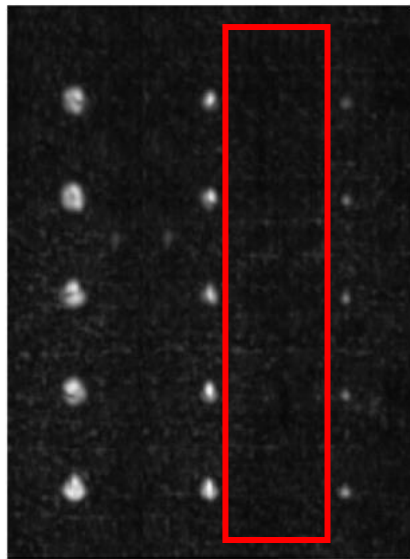
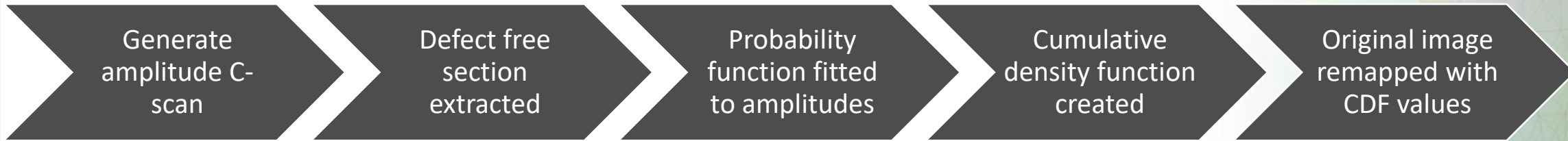

[4] Wilcox PD, Croxford AJ, Budyn N, Bevan RLT, Zhang J, Kashubin A, Cawley P. 2020 Fusion of multi-view ultrasonic data for increased detection performance in non-destructive evaluation. Proc.R.Soc.A476: 20200086



3. Machine learning approach

- Algorithms whose performance improve as they are exposed to data with the ability to learn deep features
- Comparison on You Only Look Once (YOLO), Faster R-CNN, and RetinaNet models
 - Input: Image of an ultrasonic amplitude C-scan
 - Output: Vectors with bounding box coordinates and class identifiers
- Training and validation performed only on synthetic data created with semi-analytical software CIVA

Example of CIVA generated data (left) and experimental data (right)

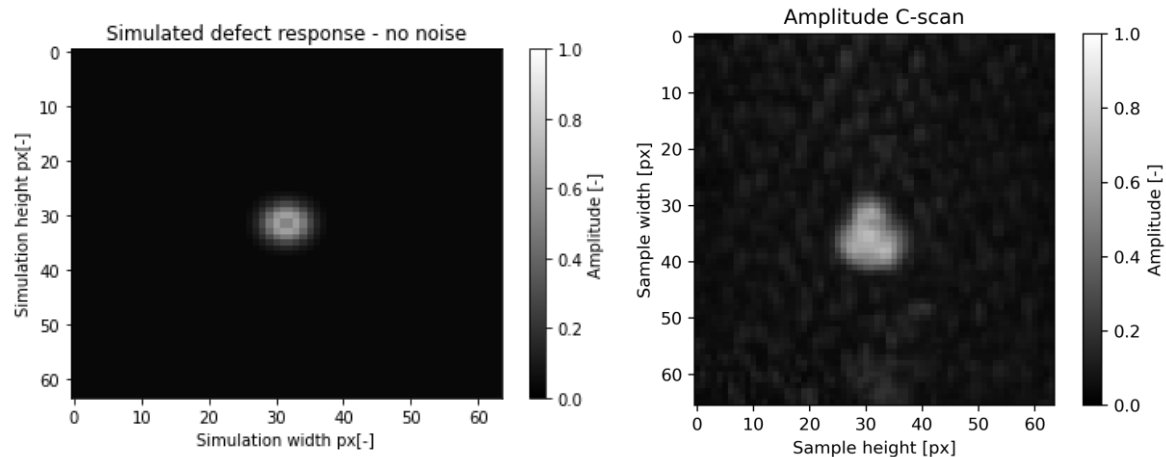

Pros and cons of CIVA

- ✓ Relatively fast generation of ultrasonic data
- ✓ Reasonably accurate representations
- ✗ Lacks finer detail in the response (noise)
- ✗ Shape of embedded defects is limited in geometry

3a. Synthetic augmentation

- Synthetic dataset created with method from McKnight et al. [5]
- Based on the idea that experimental noise consists of structural and random components

Flowchart for data augmentation

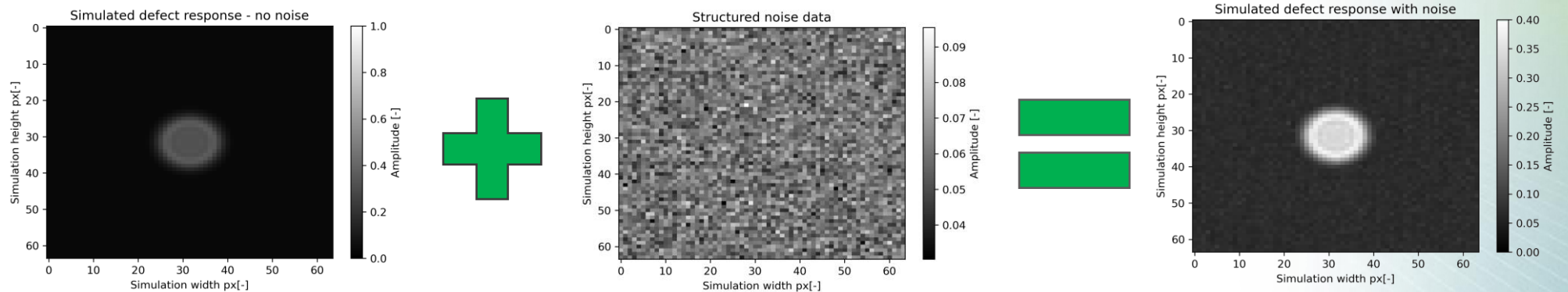
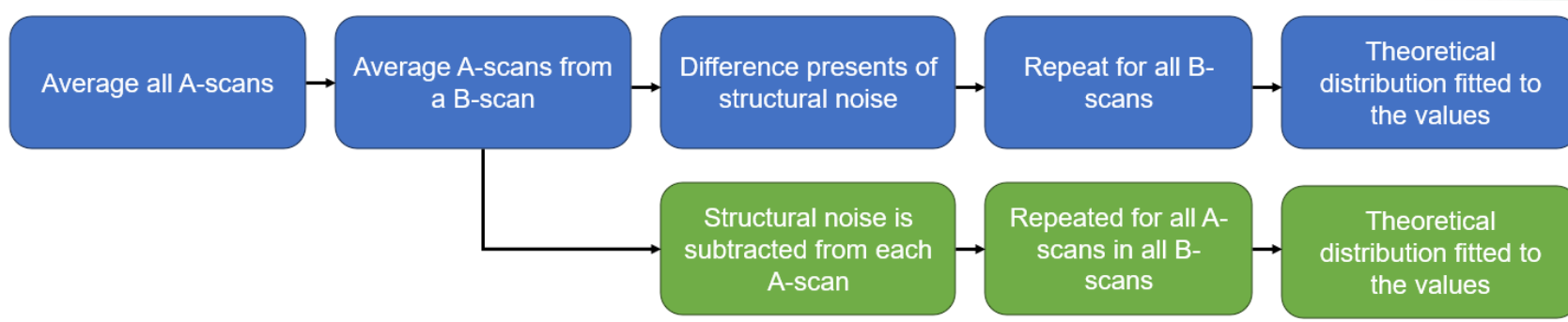

[5] McKnight et al., *Synthetic data and noise generation approaches including GANs for domain adaption of defect classification of Non-destructive ultrasonic testing.*

1. Amplitude thresholding results

Metrics:

- Precision - How many indications were defects
- Recall - **How many defects were found**
- F1 - Harmonic means between precision and recall

Results for image thresholding

Metric	6dB	9dB	12dB
Precision	0.897	0.835	0.602
Recall	0.763	0.950	1.000
F1	0.824	0.889	0.751

6dB drop

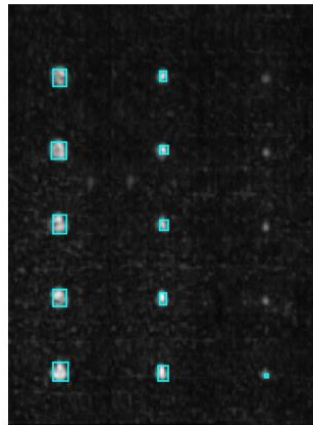

3mm defects undetected

9dB drop

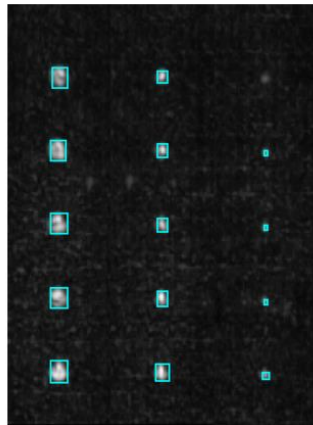

Deepest 3mm defect undetected

12dB drop

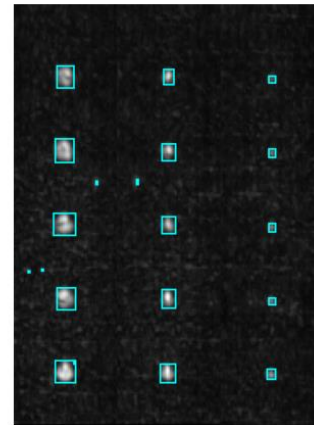

All defects detected with 2 false positives

- ✓ Explainable method
- ✓ Fast processing
- ✓ Can identify larger defects
- ✗ Poor precision with aggressive thresholding
- ✗ Poor overall performance
- ✗ **Must have high amplitude defects to work**



2. Statistical image thresholding results

Results for statistical image thresholding

Metric / Threshold	99%	99.5%	99.9%
Precision	0.593	0.849	0.936
Recall	1.000	0.988	0.913
F1	0.744	0.913	0.924

- ✓ Explainable method
- ✓ Defects don't need to be present in the scan
- ✓ Better results than standard thresholding
- ☹ Slower processing
- ☹ Precision tied to the used thresholding
- ☹ Method struggles with imperfections in the images

Comparison between 6dB drop (left) and 99.5% statistical thresholding (right)

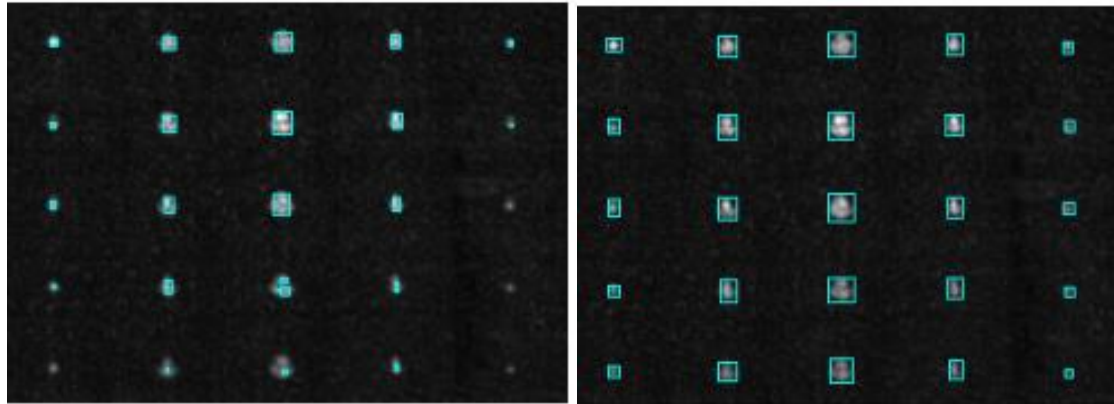

Example of false positives similar to amplitude thresholding

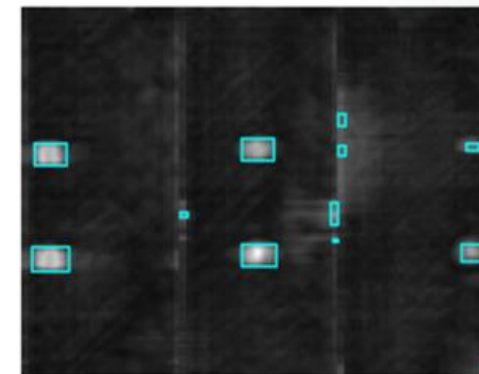

3. Machine learning approach - results

Results for image machine learning models

Model	Faster R-CNN		RetinaNet		YOLO Large		YOLO Medium	
Metric	Raw	Augmented	Raw	Augmented	Raw	Augmented	Raw	Augmented
Precision	0.982	0.989	0.928	0.922	0.950	0.926	0.983	0.978
Recall	0.956	0.964	0.958	0.985	0.950	0.986	0.930	0.981
F1	0.969	→ 0.976	0.940	→ 0.952	0.950	→ 0.955	0.956	→ 0.979

- ✓ Best overall results
- ✓ Augmentation increases performance by up to 2.3%
- ✓ Fast inference
- ✓ Training done purely on synthetic dataset
- ✗ Training of the models is relatively complex
- ✗ Explainability

Detection example with defect sizes ranging from 3.0 to 9.0 mm

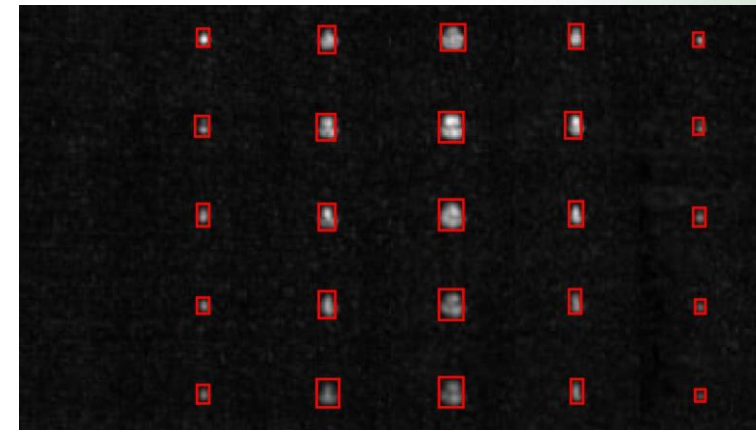

Interpretation of a challenging scan

- Due to imperfections during the scan and the need for aggressive gating to capture defects close to the surface images have areas of increased amplitude which are not defective
- This can happen to the capturing of front-wall reflections during the gating process

6dB drop

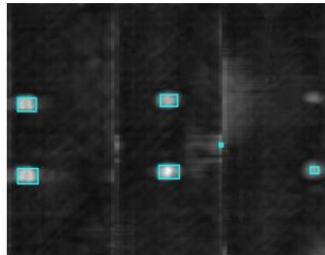

Important defect missed

99% probability

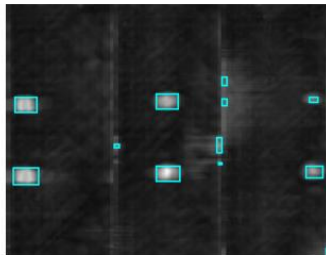

Defects found with many false positives

9dB drop

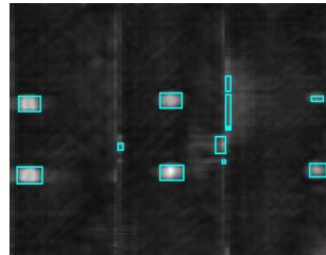

Defects found but precision deteriorates

99.5% probability

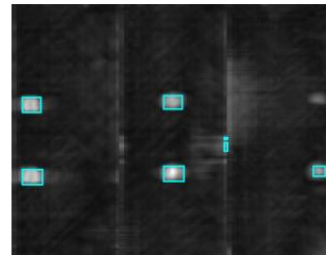

Important defect missed

12dB drop

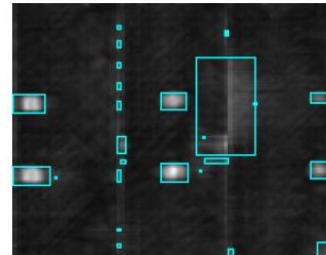

Extreme case of false positives

99.9% probability

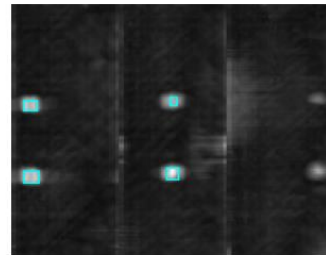

Important defect missed

Machine Learning

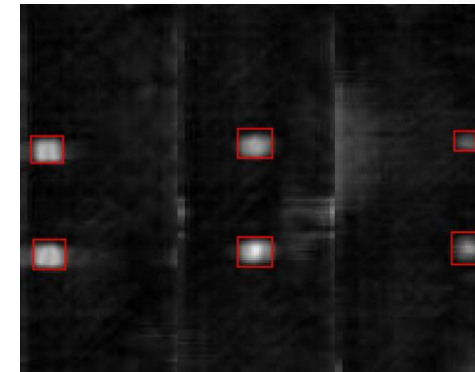

All defects located



Conclusion

- Three different methods of defect detection and localisation in amplitude C-scans were demonstrated
- Amplitude thresholding
 - Works with larger defects and clear scans
 - In absence of large reflectors, the method fails
- Statistical thresholding
 - Improves on the previous method
 - Struggles with imperfect scans and gating parameters
- Machine learning
 - Overall best results and robust
 - Most complex method with poor explainability
- For future work we aim to include defect classification and multi-modal approach to characterisation of defects



Contact

- Thank you for your attention!
- Contact: vedran.tunukovic@strath.ac.uk



Ultrasonic NDT inspection

- Ultrasonic probe emits a pulse and records reflections in time-series data
- As acoustic wave propagates through the material its energy is reduced due to attenuation, scattering and other interactions with internal structures
- Interactions with defects are impactful as oftentimes defects are great reflectors of acoustic waves
- Use of phased array systems enables the use of advanced techniques such as beamforming, linear scanning, full matrix capture, etc.

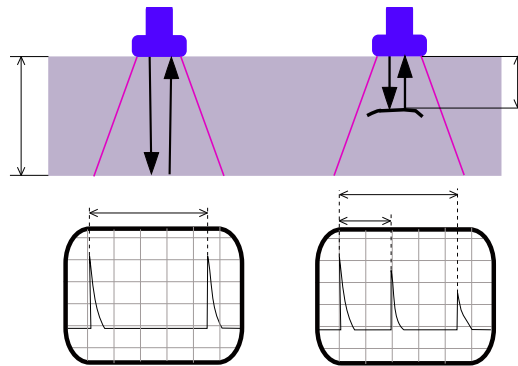

Principle of operation of ultrasonic scanning in NDT [4]

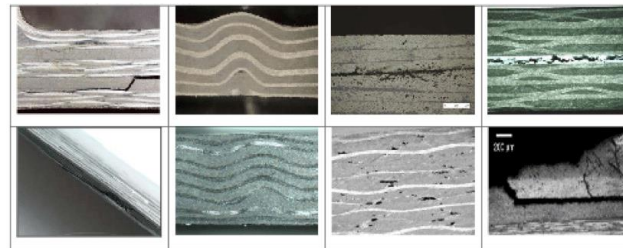

Examples of defects that can occur in Carbon Fibre Reinforced Polymers [3]

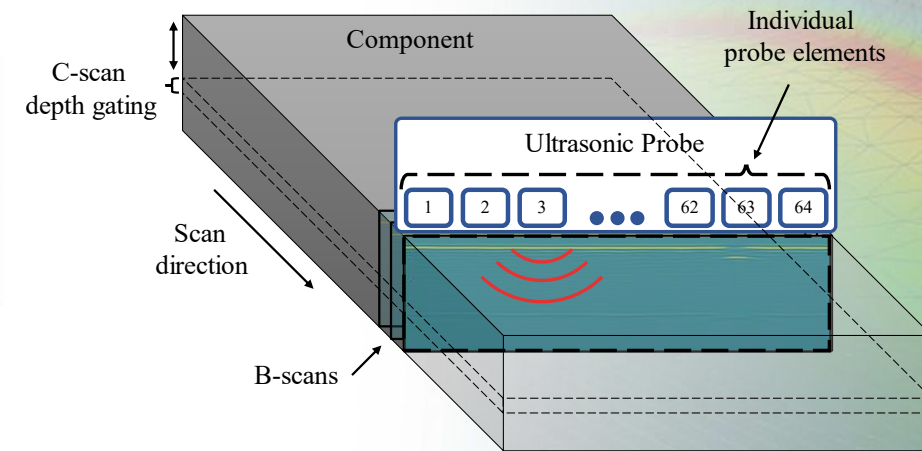

Principle of operation of phased array systems [5]

[3] Guemes et al., Structural Health Monitoring for Advanced Composite Structures: A Review, DOI: 10.3390/jcs4010013

[4] https://commons.wikimedia.org/wiki/File:UT_principe.svg

[5] McKnight et al., Synthetic data and noise generation approaches including GANs for domain adaption of defect classification of Non-destructive ultrasonic testing.

