



**Aalborg Universitet**

**AALBORG UNIVERSITY**  
DENMARK

## **QFT Framework for Robust Tuning of Power System Stabilizers**

Alavi, Seyyed Mohammad Mahdi; Izadi-Zamanabadi, Roozbeh

*Published in:*

Proceedings of 20th International Power Systems Conference (PSC2005)

*Publication date:*

2005

*Document Version*

Publisher's PDF, also known as Version of record

[Link to publication from Aalborg University](#)

*Citation for published version (APA):*

Alavi, S. M. M., & Izadi-Zamanabadi, R. (2005). QFT Framework for Robust Tuning of Power System Stabilizers. In Proceedings of 20th International Power Systems Conference (PSC2005)

### **General rights**

Copyright and moral rights for the publications made accessible in the public portal are retained by the authors and/or other copyright owners and it is a condition of accessing publications that users recognise and abide by the legal requirements associated with these rights.

- ? Users may download and print one copy of any publication from the public portal for the purpose of private study or research.
- ? You may not further distribute the material or use it for any profit-making activity or commercial gain
- ? You may freely distribute the URL identifying the publication in the public portal ?

### **Take down policy**

If you believe that this document breaches copyright please contact us at [vbn@aub.aau.dk](mailto:vbn@aub.aau.dk) providing details, and we will remove access to the work immediately and investigate your claim.

## QFT Framework for Robust Tuning of Power System Stabilizers

Seyyed Mohammad Mahdi Alavi, Roozbeh Izadi-Zamanabadi

Department of Control Engineering, Aalborg University, Denmark  
Correspondence to: Alavi\_smm@yahoo.com, riz@control.auc.dk

**Keywords:** Powers System Stabilizer (PSS), Quantitative Feedback Theory (QFT), Tunable PSS.

### Abstract

This paper discusses the use of conventional quantitative feedback design for Power System Stabilizer (PSS). An appropriate control structure of the QFT that is directly applicable to PSS, is described. Two desired performances are also proposed in order to achieve an overall improvement in damping and robustness. The efficiency of the proposed method is demonstrated on Single Machine Infinite Bus (SMIB) power system with highly uncertainty.

### 1- Introduction

The functional diagram of a conventional excitation control system is shown in figure 1. The excitation voltage  $E_{fd}$ , is supplied from the exciter and is controlled by the Automatic Voltage Regulator (AVR), to keep the terminal voltage equal to reference voltage. Although the AVR is very effective during steady state operation, it may have a negative influence on the damping of power swings in the transient state. To compensate for this a supplementary control loop, known as the power system Stabilizer (PSS), is often added as shown in figure 1 [5]. The major concerns in PSS tuning and design are to achieve an

overall improvement in damping and robustness through a simple design procedure..

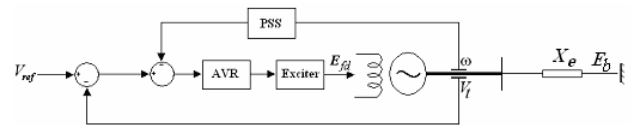

**Figure 1: Conventional excitation control system**

Quantitative feedback Theory (QFT) is an engineering method introduced to practical design of feedback systems with simple, low-order and low bandwidth controller [2]. QFT not only introduces no conservative design approach in the uncertainty description, but also provides desired performance bounds with an arbitrary selection of nominal plant. Insight available trade-off between the stability, performance, plant uncertainty, disturbance level, controller complexity and controller bandwidth, the main advantage of QFT design, is also very useful in the PSS design, where:

- Stability plays a significant role in the safety regulations.
- The magnitude of model uncertainties is typically large.
- The AVR has negative effect on the damping power factor.

From technical point of view, QFT as a graphical tool (i.e., that can graphically show the robust performance and robust stability bounds simultaneously with the specification of the operating point response) can provide simple tuning and protection abilities. The mentioned advantages suggest, “*QFT design is an appropriate method to provide a tunable PSS*”.

Following, the related background will be reviewed. In [4], the feedback controller  $G(s)$  (as PSS), was designed to maintain the system response between a lower and upper bound over all operating points, as shown in figure 2. Because of direct application of PSS into main loop, the solution presented in [4] is impractical.

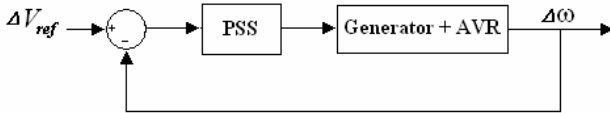

Figure 2. Control structure for PSS design as a main loop

In [3], the QFT loop shaping based on dissipativity framework was used for PSS design. Comparing the simulation results of proposed QFT design and conventional PSS design shows that the proposed approach does not necessarily improve the design performance. In [6], dominant pole region location as an effective performance criterion in PSS design was modified, termed as D-Contour. A set of discrete complex frequency point has been chosen on the D-Contour instead of the imaginary axis. As opposed to conventional QFT design, interactive shaping of the frequency response of the controller would be impracticable in [6], which leads to difficulties in design.

By investigation of the mentioned references, *the application of conventional QFT design approach for PSS design has not yet received enough attention in the literature*. The contribution of this paper is to present the conventional QFT approach as a powerful graphical approach for PSS design, which can simply be used in tuning. Two desired performances are proposed in order to achieve an overall improvement in damping and robustness

This paper is organized as follows: In section 2, the description of the plant model is presented. In section 3, the structure of the PSS on the power plant is discussed such that is applicable in conventional quantitative feedback design. This section, specially deals with appropriately selecting the desired performance. The problem is then formulated and detail design procedure is proposed. Finally the simulation results are carried out to show the effectiveness of the new proposed methodology in section 4.

## 2- The power system model

In this paper a SMIB power system is used to explain the design procedure. It has been equipped with an AVR consisting of a static excitation system. By linearizing the system about any given steady-state operating condition, the generator and excitation control system can be modeled as a fourth-order system with changes in the state variables as shown in figure 3. The set of equations and system parameters governing the behavior of this system have been described in [6].

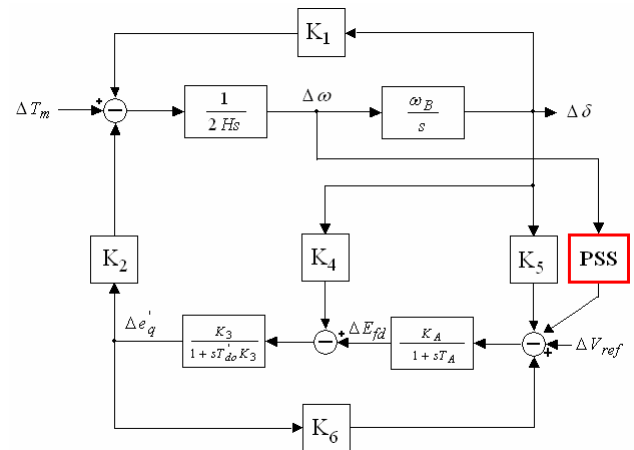

Figure 3. Block diagram of the linearized system and PSS

As shown in figure 3, the system input is the change in the voltage reference  $\Delta V_{ref}$  and the system output is the change in the rotor speed  $\Delta\omega$ . The operating conditions are also defined by the change in the value of the real power  $P$ , the reactive power  $Q$  and the impedance of the transmission line  $X_e$ . It is assumed that they are varying independently

over the wide range  $P: 0.4$  to  $1(Pu)$ ,  $Q: -0.2$  to  $0.5(Pu)$  and  $X_e: 0.2$  to  $0.5(Pu)$ . In [6], it has been shown that without a controller, the system is unstable at some operating points. It is required to design an appropriate controller in order to achieve desired responses of the low frequency oscillations.

### 3- PSS design based on conventional QFT framework

This section concerns the view of the PSS design as a conventional QFT framework, which can be effectively treated in the loop-shaping problem.

QFT design focuses on two-degree-of-freedom feedback system described in figure 4. The general QFT problem is to design the feedback compensator and the pre-filter to achieve the desired performances in spite of the uncertainty.

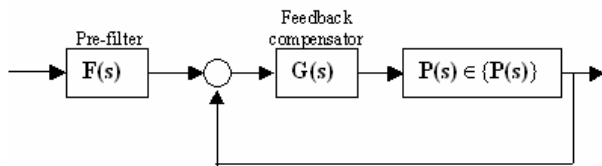

Figure 4. Two-degree-of-freedom feedback system

On the other hand, the schematic diagram of the SMIB system with the PSS, i.e., Figure 3, can be represented by unity feedback system as shown in figure 5.

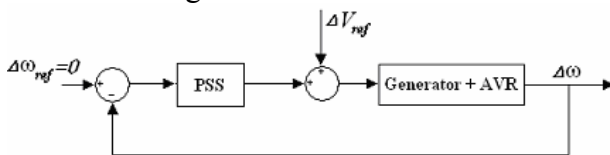

Figure 5. PSS control configuration for SMIB system

By comparing two schematic diagrams 4 and 5, it is obvious that the PSS design is exactly compatible with the conventional QFT framework, which the effect of changes in the terminal voltage is treated as an input disturbance entering the system. In practice, the change of reference speed is constant, hence  $\Delta\omega_{ref} = 0$  and pre-filter does not enter the configuration of the problem.

### 3-1 Problem formulation

In the reminder of this section, the problem is mathematically formulated and design procedure is then presented. As in conventional QFT approach, two desired specifications are introduced directly connected with the inputs of the system, i.e.,  $\Delta\omega_{ref} = 0$  and  $\Delta V_{ref}$ . After bound generation using MATLAB<sup>®</sup> QFT-Toolbox [1], robust PSS is designed by appropriately employing interactive loop function shaping such that the design bounds are satisfied.

First desired specification is related to the main objective of PSS design, dampen and eliminate the low frequency oscillations with the following equation:

$$\left| \frac{P(s)G(s)}{1+P(s)G(s)} \right|_{s=j\omega} \leq |W_T(j\omega)|.$$

$W_T(s)$  represents the desired tracking specification. In order to achieve improved damping ratio,  $W_T(s)$  is modeled as a transfer function with approximately zero steady state gain and appropriate damping factor. A typical selection has been shown in figure 6.

Second desired specification is related to decrease the negative effect of the changes in the voltage reference. As demonstrated in section 3, the effect of  $\Delta V_{ref}$  appears as input disturbance rejection problem. In order to weaken the effects of  $\Delta V_{ref}$ , this problem is formulated by:

$$\left| \frac{\Delta\omega(s)}{\Delta V_{ref}(s)} \right|_{s=j\omega} = \left| \frac{P(s)}{1+P(s)G(s)} \right|_{s=j\omega} \leq |W_D(j\omega)|$$

in QFT design.  $W_D(s)$  represents the desired disturbance rejection specification. It is modeled as a transfer function with almost zero DC gain. It is simple to show that transfer function of  $\Delta\omega/\Delta V_{ref}$  can be represented as follows with positive coefficients:

$$\frac{\Delta\omega}{\Delta V_{ref}} = \frac{-bs}{s^4 + a_3s^3 + a_2s^2 + a_1s + a_0}$$

The frequency response of  $\Delta\omega/\Delta V_{ref}$  for typical SMIB system shows extremely reduction of magnitude of  $\Delta\omega/\Delta V_{ref}$  at high

frequencies. It can be exploited to reduce conservativeness by choosing appropriate  $W_D(s)$  with sufficiently high magnitude at high frequency ranges. Typical selection has also been also shown in figure 6.

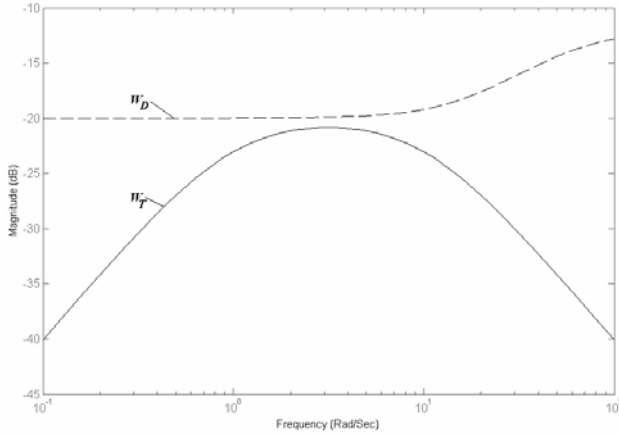

Figure 6: typical selection of  $W_T(s)$  and  $W_D(s)$

Therefore, the problem formulation of the PSS design for SMIB system in the framework of QFT design can be organized as follows:

*Consider SMIB as an uncertain plant given in figure 4. The designing task is to specify the feedback compensator to meet the desired tracking and disturbance rejection specifications (1) and (2) in order to achieve the desired damping and robustness for low frequency oscillations.*

$$\left| \frac{P(s)G(s)}{1+P(s)G(s)} \right|_{s=j\omega} \leq |W_T(j\omega)| \quad (1)$$

$$\left| \frac{P(s)}{1+P(s)G(s)} \right|_{s=j\omega} \leq |W_D(j\omega)| \quad (2)$$

where  $W_T(s)$  and  $W_D(s)$  are the desired tracking and disturbance rejection specifications respectively.

### 3-2 Design procedure

The design procedure for obtaining a robust PSS can be summarized as follows:

1. Select desired specification  $W_T$  and  $W_D$ .
2. Plot performance specifications (Robust performance bounds and robust stability bounds) using MATLAB<sup>®</sup> QFT-Toolbox

within  $\omega \in [0, \omega_h]$ .  $\omega_h$  is dependence on the bandwidth of the system. Changes in the shape of templates can be very helpful to find an appropriate frequency after which the template's shape becomes fixed. Since the low frequency response between [0.1,5] (Hz) is important here,  $\omega_h$  can be selected as [0.5,30] (rad/sec).

3. Design the QFT feedback compensator such that the desired bounds are satisfied. Robustness will be ensured if the Nichols envelope do not intersect the critical point  $(-180^\circ, 0\text{dB})$  and the nominal plant do not entered into the robust stability bounds, i.e. the U-contours.

### 4- Implementation and control design

In this section the SMIB, described in section 2 is used to show the effectiveness of the proposed procedure.

It is required to design an appropriate controller in order to achieve desired responses for the low frequency oscillations. It is shown that QFT as a powerful graphical tool can play a significant role in PSS tuning.

*Step 1:* According to section 3.1, the robust performance bounds are selected as follows:

$$W_T(s) = \frac{0.1s}{(s+1)(s/10+1)}, W_D(s) = \frac{0.1(s/20+1)}{(s/50+1)}$$

$W_T(s)$  guarantees that the maximum overshoot and settling time are lower than 0.07(Pu) and 4(sec), respectively.  $W_D(s)$  is also attenuate the effects of changes in reference voltage to be lower than  $-20(\text{dB})$  in the designed frequency range.

*Step2:* Using MATLAB<sup>®</sup> QFT-Toolbox, the related design bounds are generated within  $\omega \in [0.5, 30]$ . The composite bounds are illustrated in Figure 7. For robustness, PSS should be designed to lay the loop gain above the line to achieve desired performance. The loop gain should also be shaped such that it does not lie within the robust stability bounds.

*Step 3:* The conventional lead compensator type of PSS, in the form of

$$G(s) = K_s \frac{(1+sT_1)^2}{(1+sT_2)^2}$$

is exploited to achieve



desired controller, [6]. It is selected to show that QFT design can be easily used for tuning the conventional PSS. The gain  $K_s$  and the time constants  $T_1$  and  $T_2$  are the tunable parameters. Figure 7 shows a possible controller in the mentioned framework given by:

$$G(s) = \frac{-2.2(1+0.1351s)^2}{(1+0.0337s)^2}$$

The effectiveness of the designed controller for the case study by 5% step disturbance at the reference voltage of the AVR at various operating conditions has been illustrated in Figures 8 and 9. Figure 8 demonstrates that the angular velocity is damped as well for wide rang uncertainty region. Figure 9 also shows the control effort signal is remained on suitable values. In practical PSS implementation a “washout” term is added, but it does not influence the qualitative properties of the plot [3]. The obtained controller shows that the QFT design can be easily used for tuning the conventional PSS.

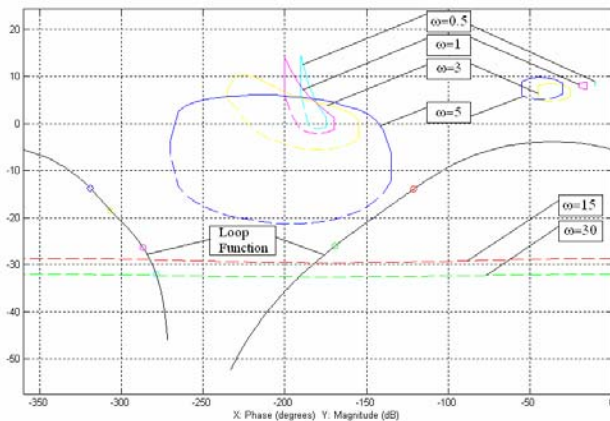
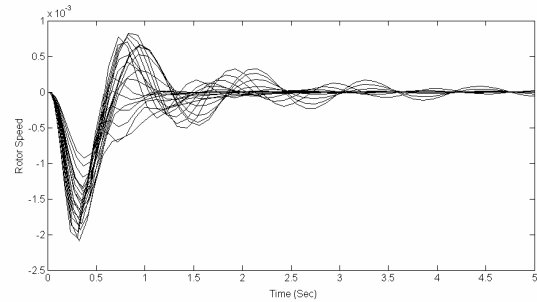

**Figure 7: Design of  $G(s)$  in Nichols Chart using MATLAB® QFT-Toolbox,  $\omega = \{0.5, 1, 3\}$  corresponds to robust stability bounds.  $\omega = \{5, 15, 30\}$  corresponds to robust performance bounds**

### Conclusion

This paper suggests the quantitative feedback theory as an appropriate method for designing PSS. An appropriate definition of the problem in the conventional QFT framework has been presented. This paper specially focuses on

appropriately selecting two desired performances in the design procedure, which are directly used in the proposed methodology. A design example has been provided to show the effectiveness of the proposed method.



**Figure 8: Controlled rotor speed for several plant cases in the region of uncertainty**

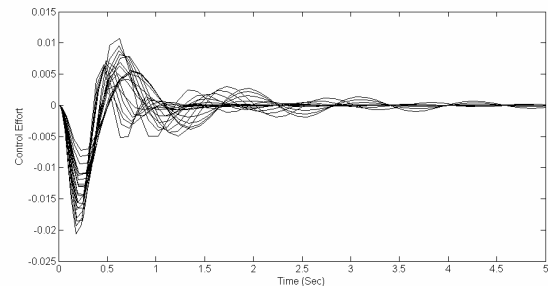

**Figure 9: Control signal for several plant cases in the region of uncertainty**

### References

- 1- C. Borghesani, Y. Chait, O. Yaniv, *Quantitative Feedback Theory Toolbox User's Guide*. The Math works Inc., 1994.
- 2- I. M. Horowitz, “survey of quantitative feedback theory”, *International Journal of Control*, vol.53, 1991, 225-291.
- 3- C. A. Jacobson, A. M. Stankovic, G. Tadmor, M. A. Stevens, Towards a Dissipativity Framework for Power System Stabilizer Design, *IEEE Trans. on Power Systems*, Vol. 11, No. 4, 1996.
- 4- A. Khaki-Sedigh, G. Alizadeh, Design of Robust Power System Stabilizer (PSS) Using Quantitative Feedback Theory, *Proceedings of Control'94*, 1994.
- 5- P. Kundur, *Power System stability and Control*, McGraw Hill, 1994.
- 6- P. S. Rao, I. Sen, Robust Tuning of Power System Stabilizers Using QFT, *IEEE Trans. on Control System Technology*, Vol. 7, No. 4, 1999.