



AALBORG UNIVERSITY
DENMARK

Aalborg Universitet

Wave Reflection Model Tests

Burcharth, Hans Falk; Larsen, Brian Juul

Publication date:
2005

Document Version
Publisher's PDF, also known as Version of record

[Link to publication from Aalborg University](#)

Citation for published version (APA):
Burcharth, H. F., & Larsen, B. J. (2005). Wave Reflection Model Tests: and overtopping recording for redesign of interior breakwater in Port of Botafoch, Ibiza. Aalborg: Department of Civil Engineering, Aalborg University. (Hydraulics and Coastal Engineering; No. 28).

General rights

Copyright and moral rights for the publications made accessible in the public portal are retained by the authors and/or other copyright owners and it is a condition of accessing publications that users recognise and abide by the legal requirements associated with these rights.

- ? Users may download and print one copy of any publication from the public portal for the purpose of private study or research.
- ? You may not further distribute the material or use it for any profit-making activity or commercial gain
- ? You may freely distribute the URL identifying the publication in the public portal ?

Take down policy

If you believe that this document breaches copyright please contact us at vbn@aub.aau.dk providing details, and we will remove access to the work immediately and investigate your claim.



+UBW

Hydraulics and Coastal Engineering Laboratory
DEPARTMENT OF CIVIL ENGINEERING
AALBORG UNIVERSITY

SOHNGAARDSHOLMSVEJ 57 DK-9000 AALBORG DENMARK
TELEPHONE +45 96 35 80 80 TELEFAX +45 98 14 25 55

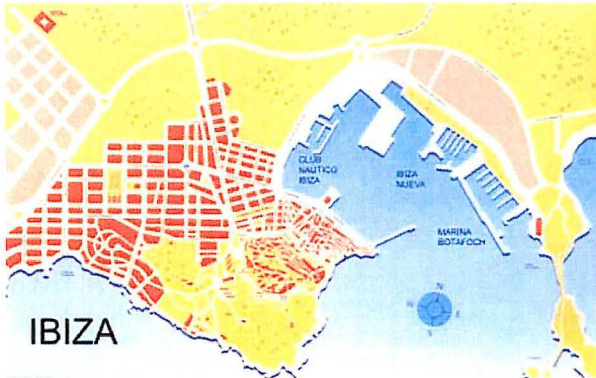

Wave Reflection Model Tests
and Overtopping Recording for Redesign of Interior
Breakwater in Port of Botafoch, Ibiza

Final Report



MARINA
BOTAFOCH

PUERTO DEPORTIVO IBIZA

August 2005

Client: Puerto Deportivo Botafoch



Hydraulics and Coastal Engineering Laboratory
DEPARTMENT OF CIVIL ENGINEERING

AALBORG UNIVERSITY

SOHNGAARDSHOLMSVEJ 57 DK-9000 AALBORG DENMARK
TELEPHONE +45 96 35 80 80 TELEFAX +45 98 14 25 55

Hydraulics and Coastal Engineering No. 28

ISSN 1603-9874

August 2005

Wave Reflection Model Tests
and Overtopping Recording for Redesign of Interior
Breakwater in Port of Botafoch, Ibiza

by

Prof. dr. tech. Hans F. Burcharth, Aalborg University
M. Sc. Brian Juul Larsen, Aalborg University

Contents

	Page
1. Introduction	4
2. Model Set-Up	5
2.1 Wave Flume	5
2.2 Length Scale	5
2.3 Cross Sections	5
2.4 Stone Material	6
3. Wave Generation and Analysis	7
3.1 Wave Generation	7
3.2 Incident Wave in Front of the Breakwater and Wave Reflection	7
4. Overtopping measurement	8
5. Test Procedure and Test Programme	8
6. Wave Reflection Test Results	8
7. Overtopping	10
8. Conclusions	10
Annex 1 – Data Sheets for Testing of Reference Structure	12
Annex 2 – Data Sheets for Testing of Existing Structure	16
Annex 3 – Data Sheets for Testing of Alternative 1	21
Annex 4 – Data Sheets for Testing of Alternative 2	28



1. Introduction

The Hydraulics and Coastal Engineering Laboratory at Aalborg University, Denmark was commissioned by Puerto Deportivo Botafoch (Ibiza, Spain) to perform a series of wave reflection model tests.

The investigation concerns the design of a new internal breakwater in the main port of Ibiza. The objective of the model tests was in the first hand to optimize the cross section to make the wave reflection low enough to ensure that unacceptable wave agitation will not occur in the port. Secondly wave overtopping was studied as well.

Besides a reference structure three different breakwater cross sections were tested in May and June 2005. The present report summarises the four status reports delivered along with the model tests

Representatives of the client Mr. Celestino Moliner and Mr. Pedro Puigdengoles visited the laboratory in the period 15 – 17/06, 2005 for inspection and discussion of the tests.

Prof. dr. techn. Hans F. Burcharth of Aalborg University was in charge of the model tests, assisted by M. Sc. Brian Juul Larsen. Engineer assistants Niels Drustrup, Kurt Sørensen and Abdul Sidighi assisted in the laboratory.

For further information on the conducted test programme contact Hans F. Burcharth (phone: +45 21 42 05 22, email: i5hfb@civil.aau.dk) or Brian Juul Larsen (phone: +45 96 35 72 31, email: i5bjl@civil.aau.dk).

All measures given in this report are in prototype values unless otherwise is stated.

Aalborg 1. August 2005

Hans F. Burcharth
Prof. dr. techn., dr. h. c.

2. Model Test Set-Up

2.1 Wave Flume

All tests were conducted in a 25 m long and 1.5 m wide wave flume. Figure 1 shows the model setup in the flume.



Figure 1. Wave flume.

2.2 Length Scale

The breakwater models were built in scale 1:15, large enough to avoid significant scale effects.

2.3 Cross Sections Tested

Four different models have been tested. Figure 2, 3, 4 and 5 show the tested cross sections.

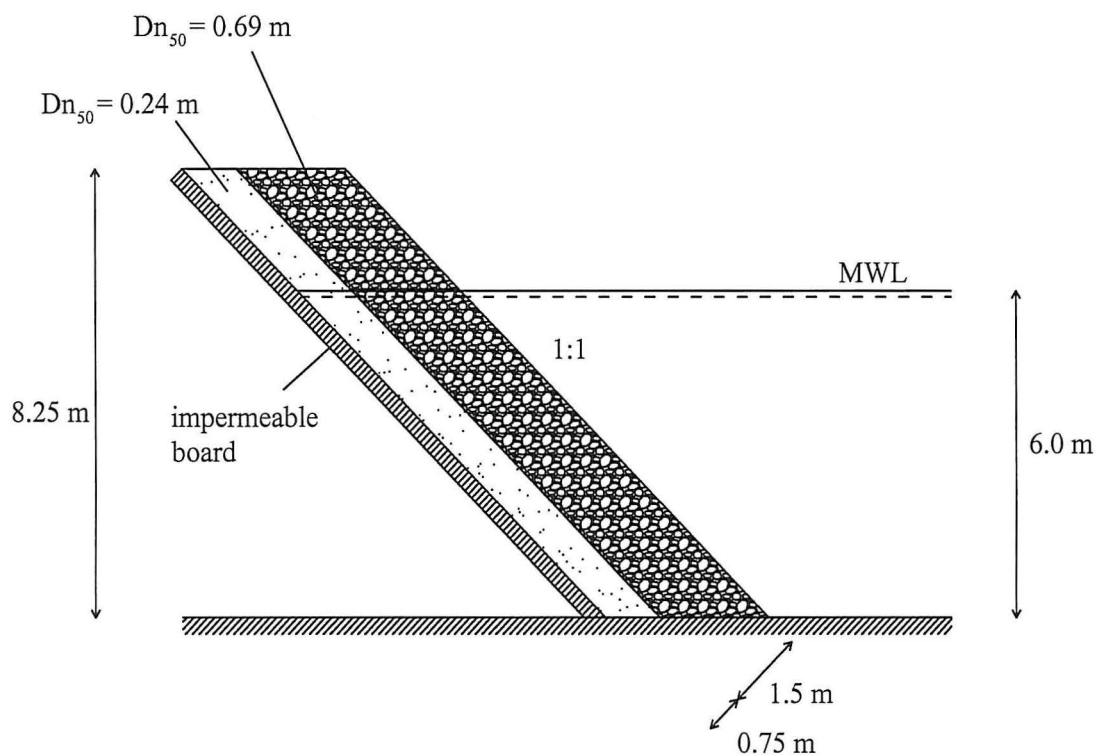

Figure 2. Reference model.

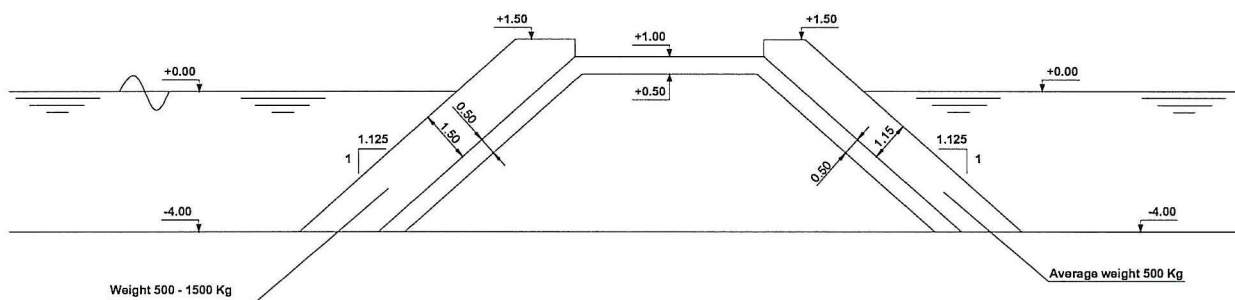

Figure 3. Existing structure.

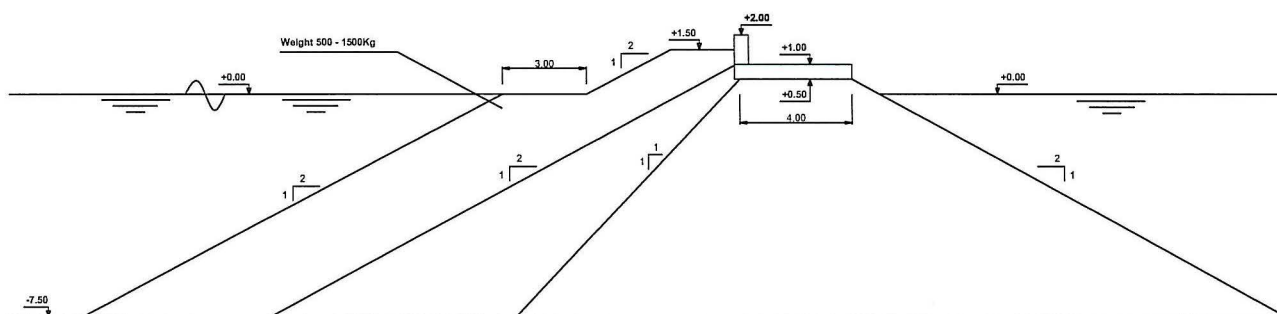

Figure 4. Proposed breakwater, Alternative 1.

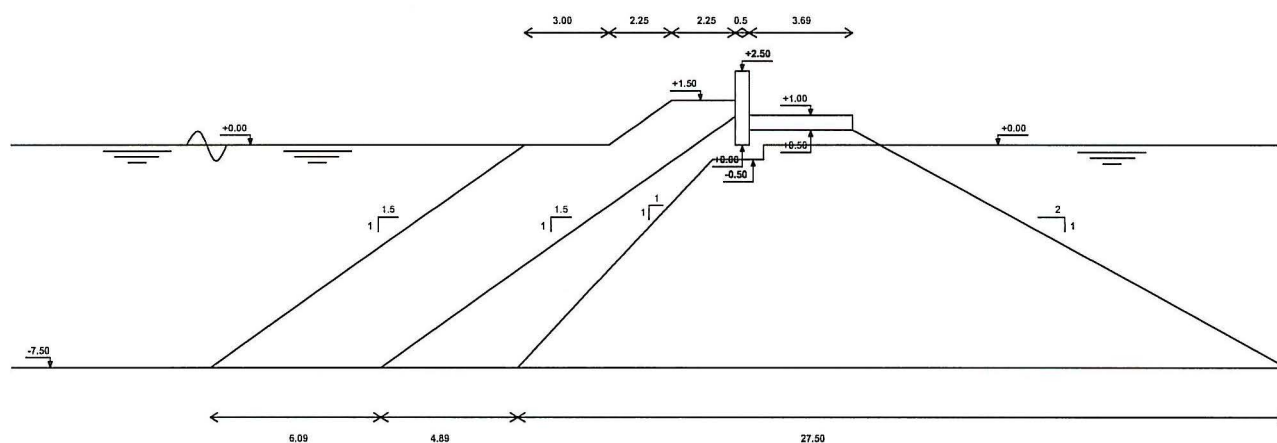

Figure 5. Proposed breakwater, Alternative 2.

For each model the variation of the reflection has been investigated through a test matrix of various wave heights and wave periods.

2.4 Stone Material

The data of the applied stone material, all with mass density 2.65 t/m^3 are given in table 1.

	Model D_{n50}	Prototype D_{n50}
Core	0.003 m	0.05 m
Filter	0.016 m	0.24 m
Armour	0.046 m	0.69 m

Table 1. Stone material.

3. Wave Generation and Analysis

3.1 Wave Generation

2D irregular waves corresponding to a JONSWAP spectrum with a peak enhancement factor of 3.3 were generated on-line by the AWASYs system developed by the laboratory. This includes on-line compensation for reflected waves.

3.2 Incident Wave in Front of the Breakwater and Wave Reflection

For the analysis of the waves near the model three gauges were placed in front of it. The incident wave spectrum was calculated using the method presented by Mansard et al. 1990. An example of separation of the measured wave spectrum into incident and reflected spectra is given in figure 6. Both frequency and time domain analysis were used.

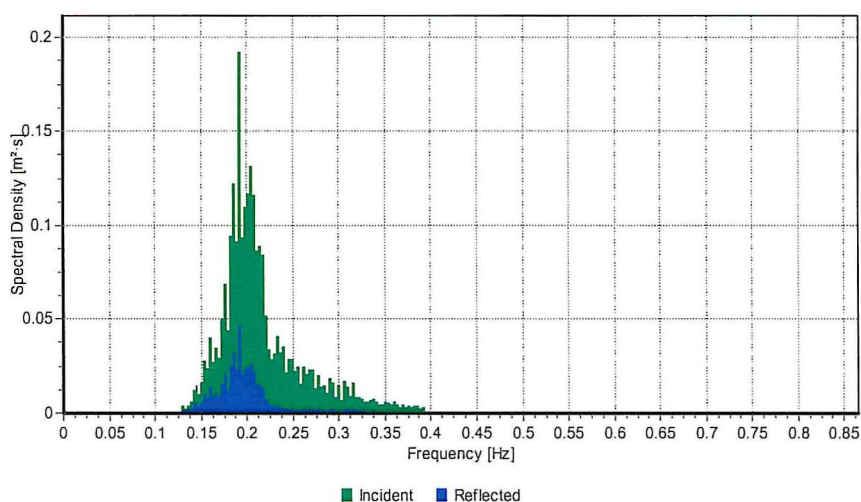

Figure 6. Incident and reflected wave spectra.

The wave parameters given in the presentation of the model test results refer to the incident spectrum in front of the breakwater, i.e. significant wave height (H_s) is defined by $H_s = 4 \cdot \sqrt{m_0}$, where m_0 is the zero moment of the incident spectrum, and the peak period (T_p) is the one corresponding to the peak frequency of the incident wave spectrum. The reflection coefficient is defined as:

$$\text{Reflection coefficient} = \sqrt{\frac{\text{Incident wave energy}}{\text{Reflected wave energy}}}$$

4. Overtopping Measurements

For Alternatives 1 and 2 the overtopping across the superstructure was collected in a tank and measured. In cases with extreme overtopping amounts it was simply stated that the amounts were much more than commonly accepted, i.e. more than approximately 10 l/m/s.

5. Test Procedure and Test Programme

For each model the sea state in terms of wave height and wave periods were increased in steps, combining the relevant ranges of significant wave heights, H_s and H_{m0} , and spectral peak wave period, T_p . The tested sea states are listed in table 2, also showing the results of the reflection investigations.

6. Wave Reflection Test Results

The wave reflection coefficients for the four models as obtained in the model tests by time domain and frequency domain analyses are given in table 2. It is seen that the results of the two types of analyses compare very well.

Wave Reflection Model Tests

Model	Test No.	Depth [m]	T_p [s]	H_{m0} [m]	H_s [m]	Reflection coefficients	
						time domain	freq domain
Reference	1.1	6.0	5.2	0.36	0.35	0.4577	0.4537
	1.2	6.0	4.9	0.66	0.64	0.4257	0.4175
	1.3	6.0	5.2	0.99	0.94	0.4466	0.4253
	1.4	6.0	5.0	1.29	1.26	0.3555	0.3293
	1.5	6.0	7.9	0.38	0.40	0.6666	0.6402
	1.6	6.0	8.3	0.64	0.72	0.6512	0.6199
	1.7	6.0	7.7	1.02	1.05	0.5059	0.4709
Existing	2.1	4.0	5.0	0.31	0.30	0.4313	0.4257
	2.2	4.0	4.8	0.64	0.61	0.4666	0.4531
	2.3	4.0	5.0	1.07	1.02	0.4856	0.4603
	2.4	4.0	8.6	0.37	0.36	0.7595	0.7335
	2.5	4.0	8.6	0.73	0.71	0.7466	0.7222
	2.6	4.0	8.3	1.21	1.20	0.7072	0.6746
	2.7	4.0	10.9	0.35	0.37	0.7956	0.7677
	2.8	4.0	10.9	0.68	0.72	0.7635	0.7400
	2.9	4.0	10.9	1.14	1.19	0.7039	0.6732
Alternative 1	3.1	7.5	5.2	0.41	0.40	0.1268	0.1184
	3.2	7.5	5.0	0.82	0.80	0.1113	0.1027
	3.3	7.5	5.0	1.37	1.32	0.1125	0.0911
	3.4	7.5	8.1	0.47	0.46	0.2056	0.1998
	3.5	7.5	7.9	0.97	0.95	0.2103	0.2182
	3.6	7.5	8.1	1.62	1.55	0.2222	0.2123
	3.7	7.5	10.6	0.46	0.44	0.4195	0.418
	3.8	7.5	10.6	0.89	0.86	0.4004	0.402
	3.9	7.5	10.6	1.12	1.04	0.3551	0.329
	3.10	8.3	5.0	0.42	0.41	0.1273	0.119
	3.11	8.3	8.1	0.49	0.46	0.1811	0.1747
	3.12	8.3	11.8	0.48	0.46	0.338	0.3301
Alternative 2	4.1	7.5	5.1	0.43	0.41	0.2666	0.239
	4.2	7.5	5.1	0.82	0.81	0.2059	0.2011
	4.3	7.5	5.0	1.46	1.44	0.1695	0.1406
	4.4	7.5	8.1	0.47	0.45	0.4095	0.3919
	4.5	7.5	8.1	0.86	0.82	0.3812	0.3616
	4.6	7.5	8.1	1.60	1.54	0.327	0.3183
	4.7	7.5	10.2	0.47	0.45	0.5439	0.5299
	4.8	7.5	10.6	0.95	0.90	0.5603	0.5444
	4.9	7.5	10.6	1.59	1.52	0.5033	0.4913
	4.10	8.0	5.3	0.41	0.40	0.1626	0.1226
	4.11	8.0	8.1	0.50	0.48	0.2754	0.2613
	4.12	8.0	10.2	0.47	0.45	0.4963	0.4831

Table 2. Test programme with results.

Details of all the test results are given in Annex 1 – 4.

7. Overtopping

The average overtopping discharge per second and per metre of the crest, \bar{q} , measured for alternatives 1 and 2 are given in table 3.

Model	Test No.	h [m]	R _c [m]	T _p [s]	H _{m0} [m]	H _s [m]	\bar{q} [l/m/s]
Alternative 1	3.1	7.5	2.0	5.2	0.41	0.40	nothing
	3.2	7.5	2.0	5.0	0.82	0.80	a few drops
	3.3	7.5	2.0	5.0	1.37	1.32	0.37
	3.4	7.5	2.0	8.1	0.47	0.46	nothing
	3.5	7.5	2.0	7.9	0.97	0.95	a few drops
	3.6	7.5	2.0	8.1	1.62	1.55	more than 10
	3.7	7.5	2.0	10.6	0.46	0.44	nothing
	3.8	7.5	2.0	10.6	0.89	0.86	0.02
	3.9	7.5	2.0	10.6	1.12	1.04	more than 10
	3.10	8.3	1.2	5.0	0.42	0.41	a few drops
	3.11	8.3	1.2	8.1	0.49	0.46	a few drops
	3.12	8.3	1.2	11.8	0.48	0.46	a few drops
Alternative 2	4.1	7.5	2.0	5.1	0.43	0.41	nothing
	4.2	7.5	2.0	5.1	0.82	0.81	a few drops
	4.3	7.5	2.0	5.0	1.46	1.44	0.13
	4.4	7.5	2.0	8.1	0.47	0.45	nothing
	4.5	7.5	2.0	8.1	0.86	0.82	a few drops
	4.6	7.5	2.0	8.1	1.60	1.54	1.7
	4.7	7.5	2.0	10.2	0.47	0.45	nothing
	4.8	7.5	2.0	10.6	0.95	0.90	0.35
	4.9	7.5	2.0	10.6	1.59	1.52	2.5
	4.10	8.0	1.5	5.3	0.41	0.40	nothing
	4.11	8.0	1.5	8.1	0.50	0.48	nothing
	4.12	8.0	1.5	10.2	0.47	0.45	nothing

Table 3. Average overtopping discharge. R_c is the freeboard.

8. Conclusions

The model tests show that the wave reflection coefficients for the proposed two alternatives are significantly lower than for the existing structure. Figure 7 shows the results of the wave reflection tests for the existing structure and the two proposed alternatives.

Evaluation of the overtopping test results for determination of the superstructure design crest level must be based on statistics of waves in front of the structure and the planned use of the breakwater crest.

Wave Reflection Model Tests

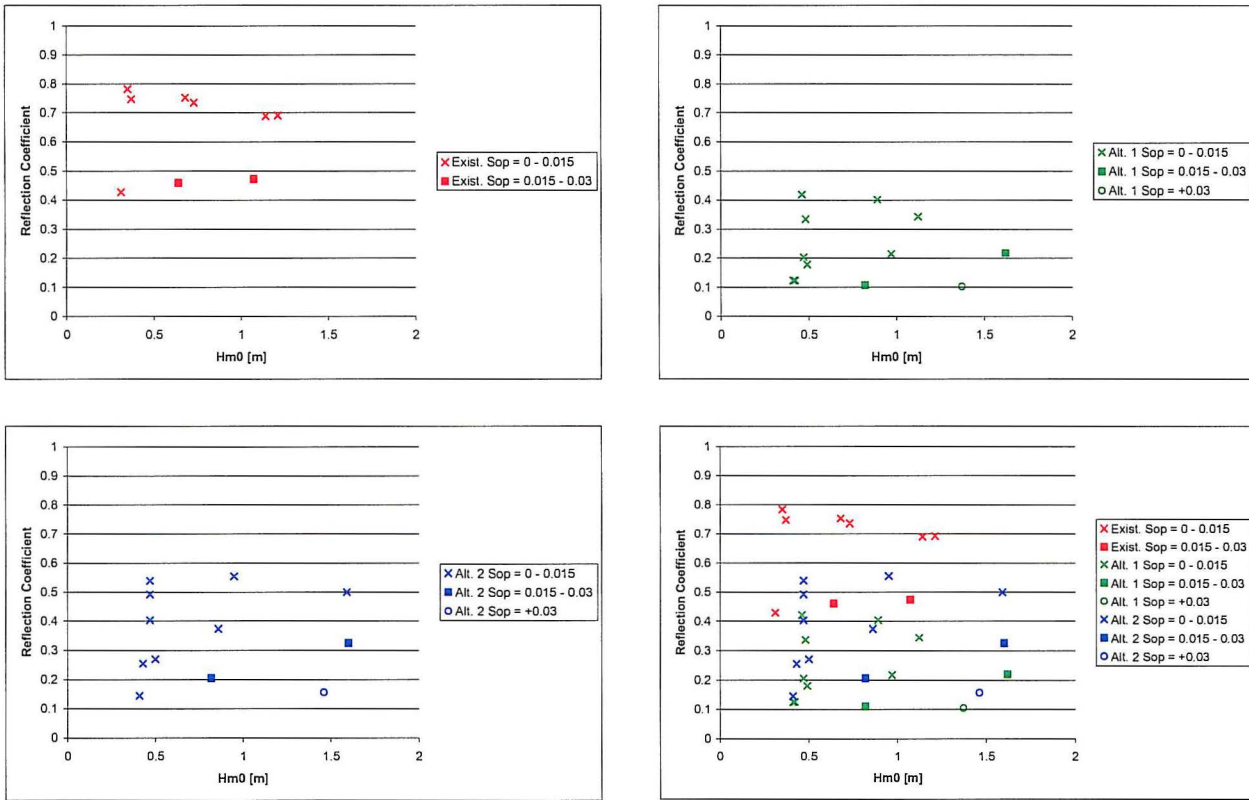

Figure 7. Result of wave reflection tests.

Annex 1 – Data Sheets for Testing of Reference Structure

Test 1.1

Time Domain Analysis:

Reflection = 0.4577, $H_s = 0.35$ m, $H_{max} = 0.68$ m, $T_m = 4.5$ s, $T_{H1/3} = 4.8$ s, 1094 waves
(In model scale: $H_s = 0.023$ m, $H_{max} = 0.045$ m, $T_m = 1.2$ s, $T_{H1/3} = 1.3$ s)

Frequency Domain Analysis:

Reflection = 0.4537, $H_{m0} = 0.36$ m, $T_p = 5.2$ s
(In model scale: $H_{m0} = 0.024$ m, $T_p = 1.3$ s)

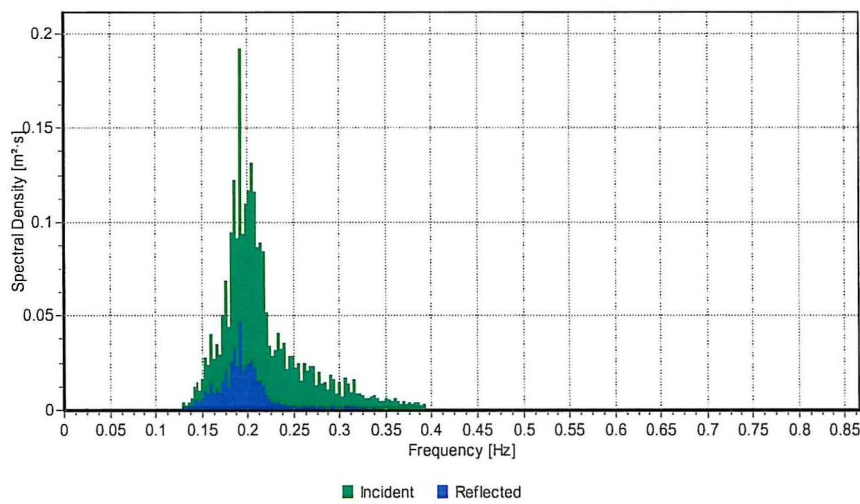

Test 1.2

Time Domain Analysis:

Reflection = 0.4257, $H_s = 0.64$ m, $H_{max} = 1.39$ m, $T_m = 4.6$ s, $T_{H1/3} = 4.8$ s, 1079 waves
(In model scale: $H_s = 0.043$ m, $H_{max} = 0.093$ m, $T_m = 1.2$ s, $T_{H1/3} = 1.2$ s)

Frequency Domain Analysis:

Reflection = 0.4175, $H_{m0} = 0.66$ m, $T_p = 4.9$ s
(In model scale: $H_{m0} = 0.044$ m, $T_p = 1.3$ s)

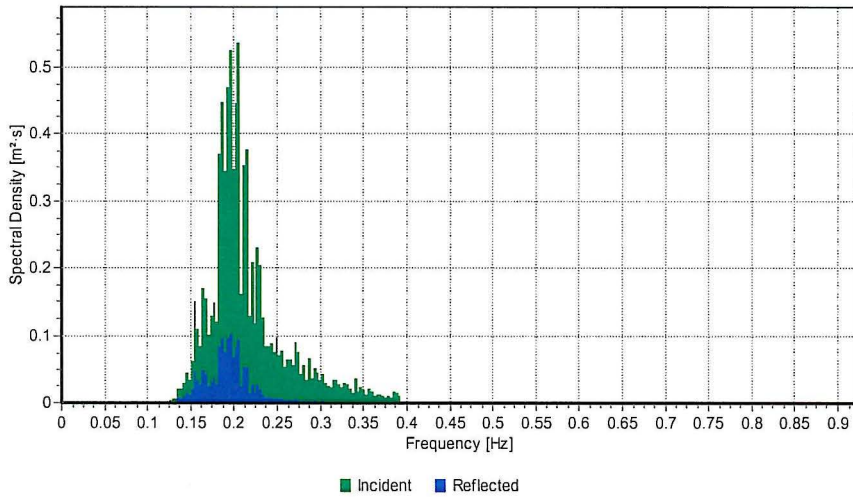

Test 1.3

Time Domain Analysis:

Reflection = 0.4466, $H_s = 0.94$ m, $H_{max} = 1.69$ m, $T_m = 4.4$ s, $T_{H1/3} = 4.9$ s, 1132 waves
(In model scale: $H_s = 0.063$ m, $H_{max} = 0.112$ m, $T_m = 1.1$ s, $T_{H1/3} = 1.3$ s)

Frequency Domain Analysis:

Reflection = 0.4253, $H_{m0} = 0.99$ m, $T_p = 5.2$ s
(In model scale: $H_{m0} = 0.066$ m, $T_p = 1.3$ s)

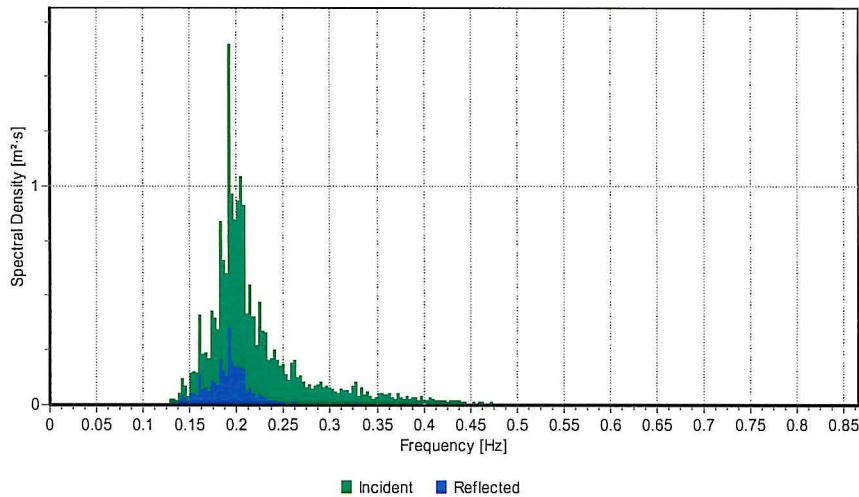

Test 1.4

Time Domain Analysis:

Reflection = 0.3555, $H_s = 1.26$ m, $H_{max} = 2.33$ m, $T_m = 4.4$ s, $T_{H1/3} = 4.8$ s, 1124 waves
(In model scale: $H_s = 0.084$ m, $H_{max} = 0.155$ m, $T_m = 1.1$ s, $T_{H1/3} = 1.2$ s)

Frequency Domain Analysis:

Reflection = 0.3293, $H_{m0} = 1.29$ m, $T_p = 5.0$ s
(In model scale: $H_{m0} = 0.086$ m, $T_p = 1.3$ s)

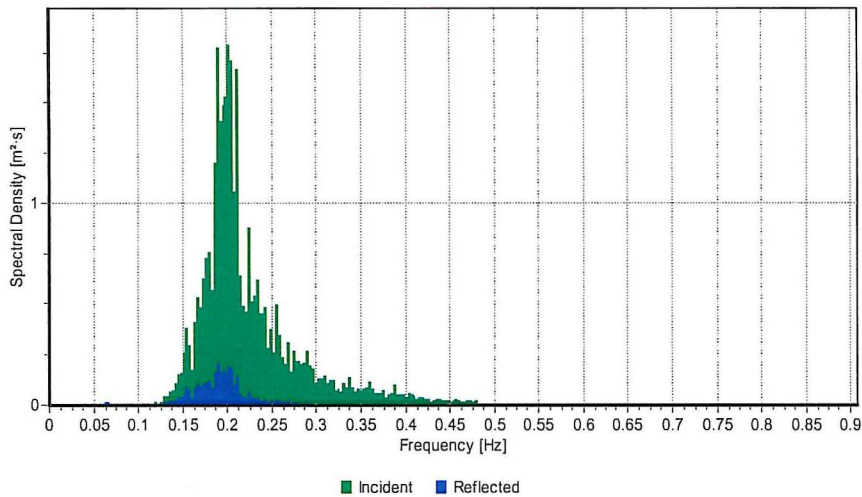

Test 1.5

Time Domain Analysis:

Reflection = 0.6666, $H_s = 0.40$ m, $H_{max} = 0.76$ m, $T_m = 6.8$ s, $T_{H1/3} = 7.7$ s, 1183 waves
(In model scale: $H_s = 0.027$ m, $H_{max} = 0.051$ m, $T_m = 1.8$ s, $T_{H1/3} = 2.0$ s)

Frequency Domain Analysis:

Reflection = 0.6402, $H_{m0} = 0.38$ m, $T_p = 7.9$ s
(In model scale: $H_{m0} = 0.025$ m, $T_p = 2.0$ s)

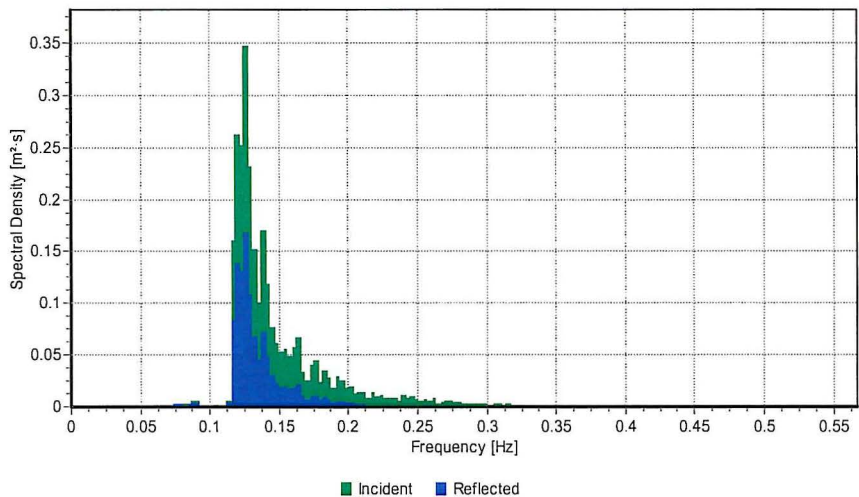

Test 1.6

Time Domain Analysis:

Reflection = 0.6512, $H_s = 0.72$ m, $H_{max} = 1.32$ m, $T_m = 6.9$ s, $T_{H1/3} = 7.8$ s, 1169 waves
(In model scale: $H_s = 0.048$ m, $H_{max} = 0.088$ m, $T_m = 1.8$ s, $T_{H1/3} = 2.0$ s)

Frequency Domain Analysis:

Reflection = 0.6199, $H_{m0} = 0.64$ m, $T_p = 8.3$ s
(In model scale: $H_{m0} = 0.043$ m, $T_p = 2.2$ s)

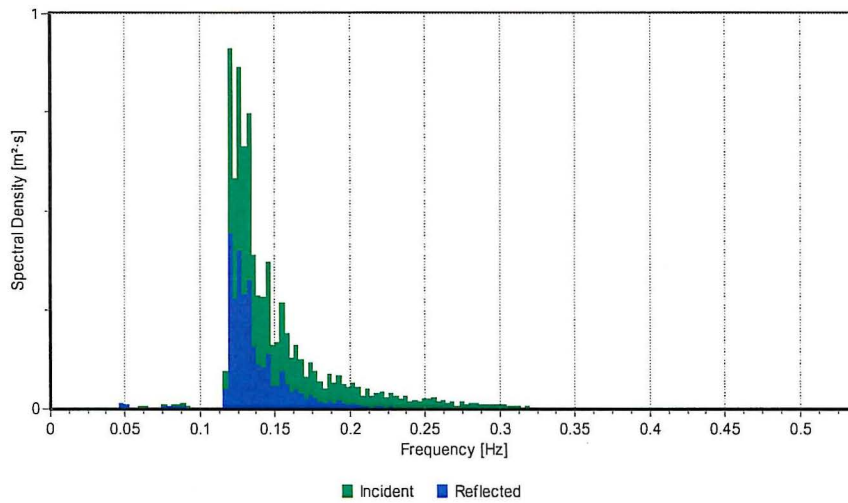

Test 1.7

Time Domain Analysis:

Reflection = 0.5059, $H_s = 1.05$ m, $H_{max} = 1.97$ m, $T_m = 6.8$ s, $T_{H1/3} = 7.8$ s, 1191 waves
(In model scale: $H_s = 0.070$ m, $H_{max} = 0.131$ m, $T_m = 1.7$ s, $T_{H1/3} = 2.0$ s)

Frequency Domain Analysis:

Reflection = 0.4709, $H_{m0} = 1.02$ m, $T_p = 7.7$ s
(In model scale: $H_{m0} = 0.068$ m, $T_p = 2.0$ s)

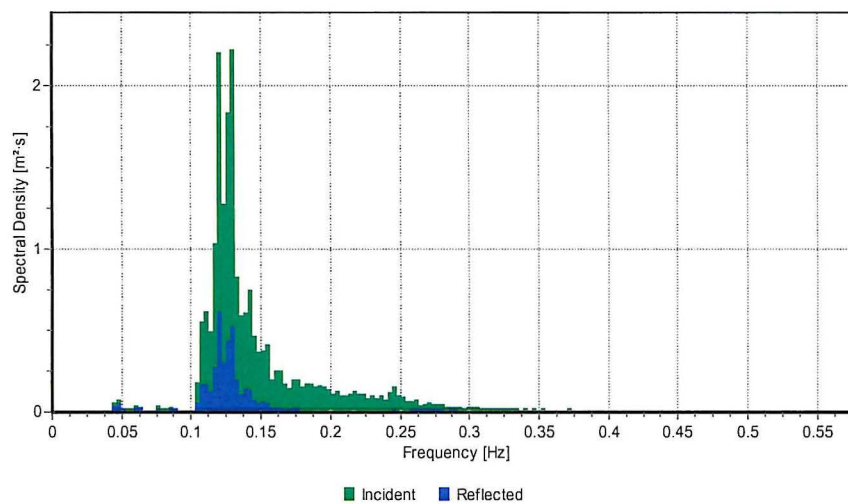

Annex 2 – Data Sheets for Testing of Existing Structure

Test 2.1

Time Domain Analysis:

Reflection = 0.4313, $H_s = 0.30$ m, $H_{max} = 0.57$ m, $T_m = 4.5$ s, $T_{H1/3} = 4.9$ s, 1100 waves
(In model scale: $H_s = 0.020$ m, $H_{max} = 0.038$ m, $T_m = 1.2$ s, $T_{H1/3} = 1.3$ s)

Frequency Domain Analysis:

Reflection = 0.4257, $H_{m0} = 0.31$ m, $T_p = 5.0$ s
(In model scale: $H_{m0} = 0.021$ m, $T_p = 1.3$ s)

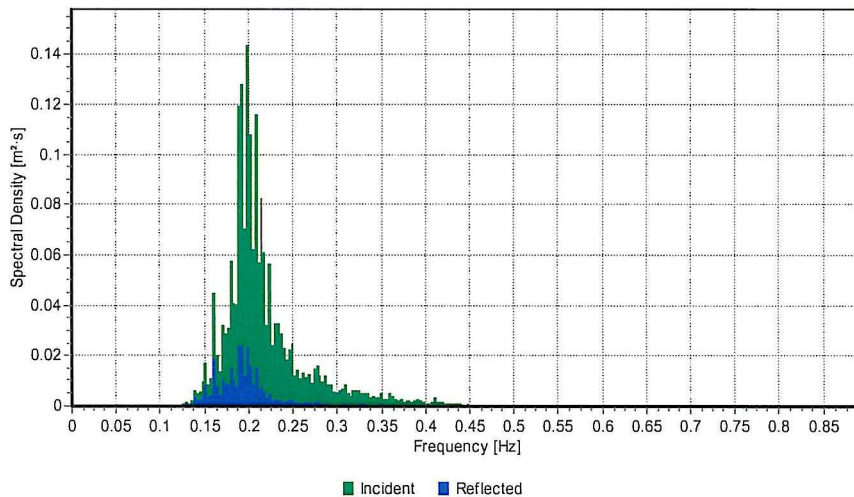

Test 2.2

Time Domain Analysis:

Reflection = 0.4666, $H_s = 0.61$ m, $H_{max} = 1.14$ m, $T_m = 4.4$ s, $T_{H1/3} = 4.9$ s, 1114 waves
(In model scale: $H_s = 0.041$ m, $H_{max} = 0.076$ m, $T_m = 1.1$ s, $T_{H1/3} = 1.3$ s)

Frequency Domain Analysis:

Reflection = 0.4531, $H_{m0} = 0.64$ m, $T_p = 4.8$ s
(In model scale: $H_{m0} = 0.043$ m, $T_p = 1.2$ s)

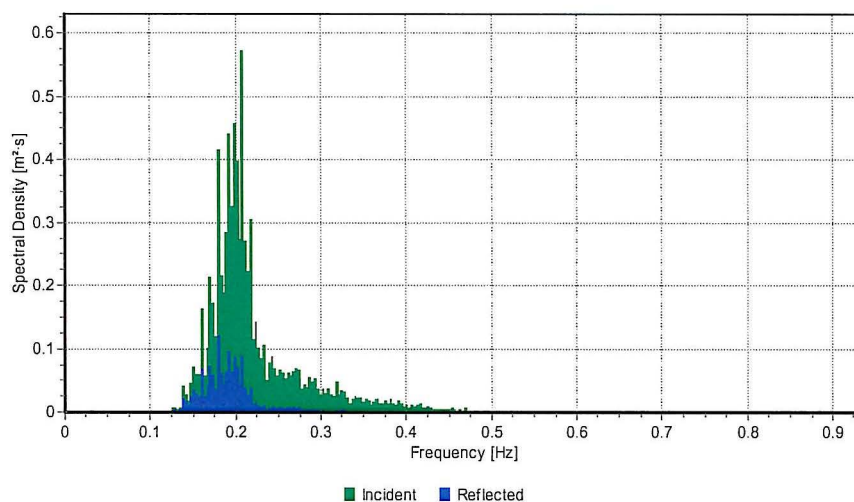

Test 2.3

Time Domain Analysis:

Reflection = 0.4856, $H_s = 1.02$ m, $H_{max} = 1.83$ m, $T_m = 4.4$ s, $T_{H1/3} = 4.9$ s, 1118 waves
 (In model scale: $H_s = 0.068$ m, $H_{max} = 0.122$ m, $T_m = 1.1$ s, $T_{H1/3} = 1.3$ s)

Frequency Domain Analysis:

Reflection = 0.4603, $H_{m0} = 1.07$ m, $T_p = 5.0$ s
 (In model scale: $H_{m0} = 0.071$ m, $T_p = 1.3$ s)

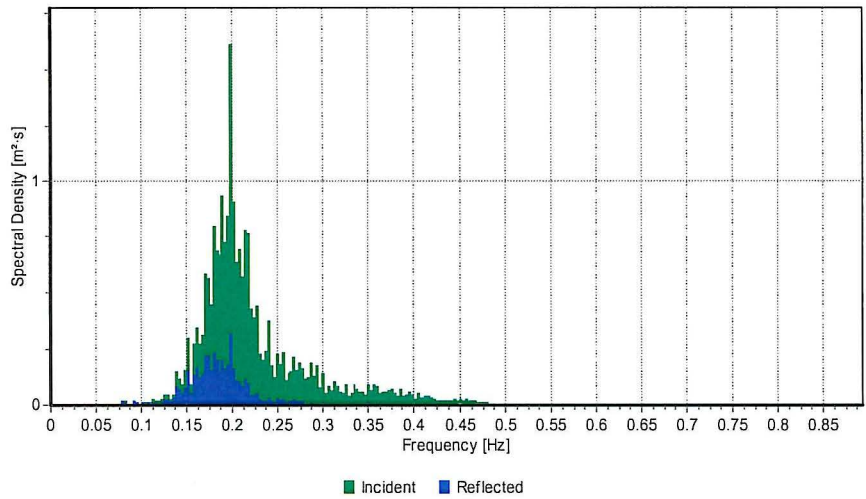

Test 2.4

Time Domain Analysis:

Reflection = 0.7595, $H_s = 0.36$ m, $H_{max} = 0.61$ m, $T_m = 6.9$ s, $T_{H1/3} = 7.7$ s, 1168 waves
 (In model scale: $H_s = 0.024$ m, $H_{max} = 0.041$ m, $T_m = 1.8$ s, $T_{H1/3} = 2.0$ s)

Frequency Domain Analysis:

Reflection = 0.7335, $H_{m0} = 0.37$ m, $T_p = 8.6$ s
 (In model scale: $H_{m0} = 0.025$ m, $T_p = 2.2$ s)

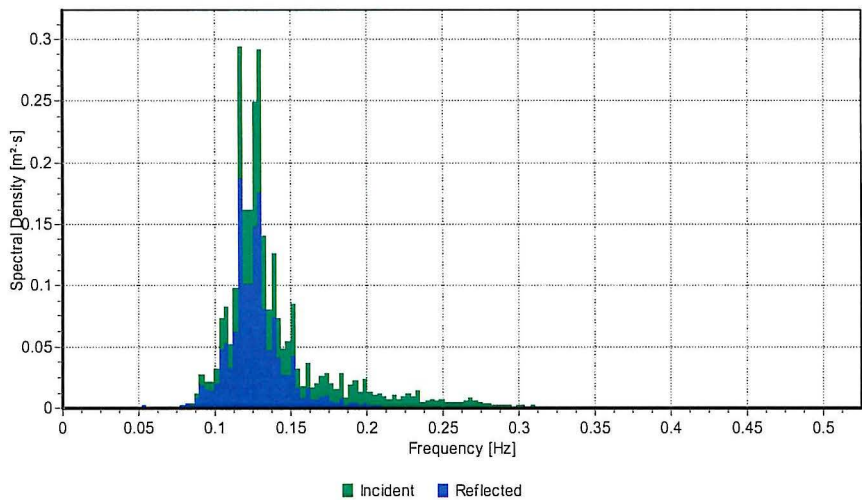

Test 2.5

Time Domain Analysis:

Reflection = 0.7466, $H_s = 0.71$ m, $H_{max} = 1.25$ m, $T_m = 6.8$ s, $T_{H1/3} = 7.7$ s, 1189 waves
(In model scale: $H_s = 0.047$ m, $H_{max} = 0.083$ m, $T_m = 1.7$ s, $T_{H1/3} = 2.0$ s)

Frequency Domain Analysis:

Reflection = 0.7222, $H_{m0} = 0.73$ m, $T_p = 8.6$ s
(In model scale: $H_{m0} = 0.048$ m, $T_p = 2.2$ s)

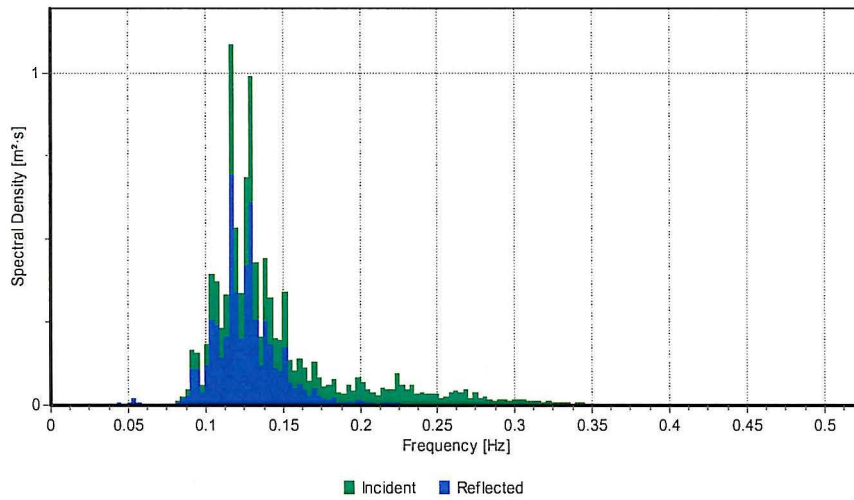

Test 2.6

Time Domain Analysis:

Reflection = 0.7072, $H_s = 1.20$ m, $H_{max} = 1.97$ m, $T_m = 6.8$ s, $T_{H1/3} = 7.6$ s, 1189 waves
(In model scale: $H_s = 0.080$ m, $H_{max} = 0.132$ m, $T_m = 1.7$ s, $T_{H1/3} = 2.0$ s)

Frequency Domain Analysis:

Reflection = 0.6746, $H_{m0} = 1.21$ m, $T_p = 8.3$ s
(In model scale: $H_{m0} = 0.080$ m, $T_p = 2.2$ s)

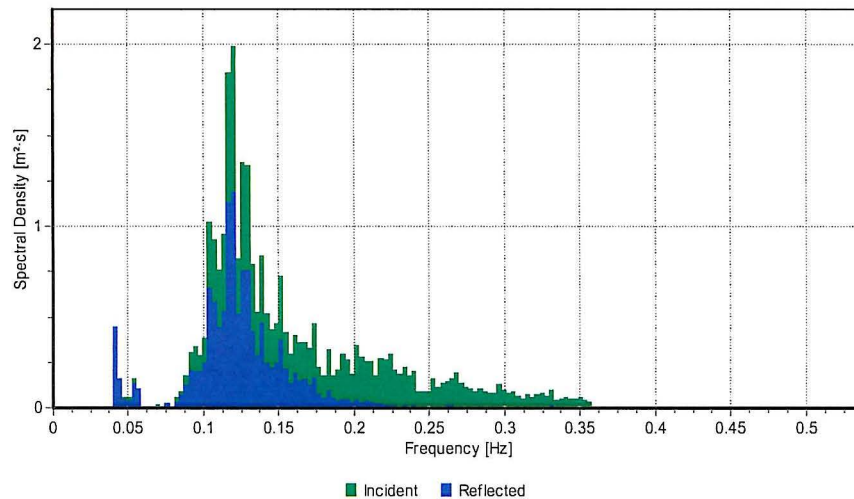

Test 2.7

Time Domain Analysis:

Reflection = 0.7956, $H_s = 0.37$ m, $H_{max} = 0.71$ m, $T_m = 9.2$ s, $T_{H1/3} = 10.5$ s, 1156 waves
 (In model scale: $H_s = 0.024$ m, $H_{max} = 0.047$ m, $T_m = 2.4$ s, $T_{H1/3} = 2.7$ s)

Frequency Domain Analysis:

Reflection = 0.7677, $H_{m0} = 0.35$ m, $T_p = 10.9$ s
 (In model scale: $H_{m0} = 0.023$ m, $T_p = 2.8$ s)

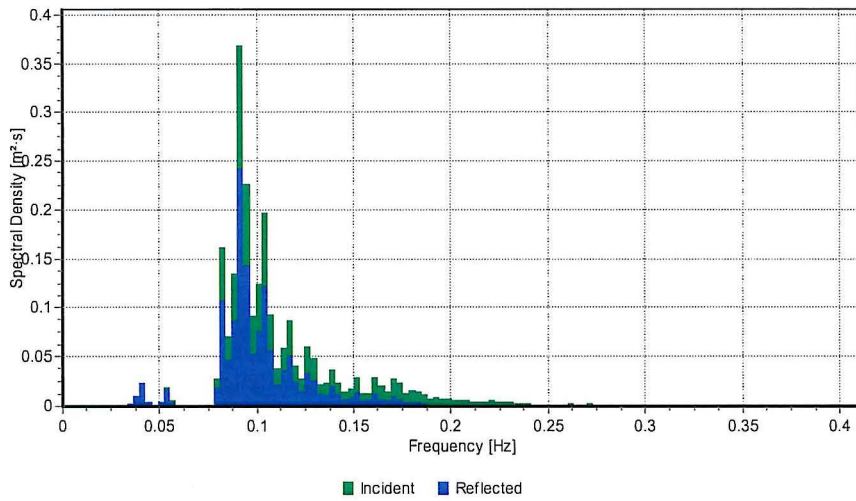

Test 2.8

Time Domain Analysis:

Reflection = 0.7635, $H_s = 0.72$ m, $H_{max} = 1.32$ m, $T_m = 9.0$ s, $T_{H1/3} = 10.3$ s, 1189 waves
 (In model scale: $H_s = 0.048$ m, $H_{max} = 0.088$ m, $T_m = 2.3$ s, $T_{H1/3} = 2.7$ s)

Frequency Domain Analysis:

Reflection = 0.7400, $H_{m0} = 0.68$ m, $T_p = 10.9$ s
 (In model scale: $H_{m0} = 0.045$ m, $T_p = 2.8$ s)

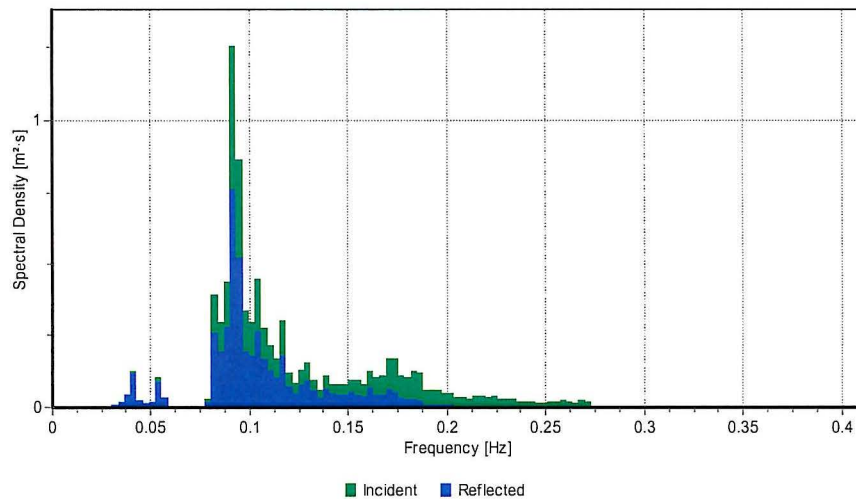

Test 2.9

Time Domain Analysis:

Reflection = 0.7039, $H_s = 1.19$ m, $H_{max} = 1.83$ m, $T_m = 8.3$ s, $T_{H1/3} = 9.8$ s, 1286 waves
(In model scale: $H_s = 0.079$ m, $H_{max} = 0.122$ m, $T_m = 2.1$ s, $T_{H1/3} = 2.5$ s)

Frequency Domain Analysis:

Reflection = 0.6732, $H_{m0} = 1.14$ m, $T_p = 10.9$ s
(In model scale: $H_{m0} = 0.076$ m, $T_p = 2.8$ s)

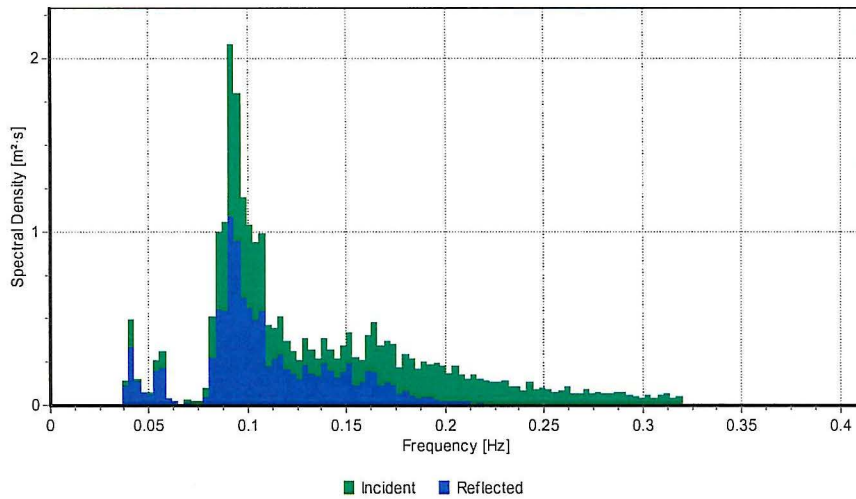

Annex 3 – Data Sheets for Testing of Alternative 1

Test 3.1

Time Domain Analysis:

Reflection = 0.1268, $H_s = 0.40$ m, $H_{max} = 0.72$ m, $T_m = 4.6$ s, $T_{H1/3} = 4.8$ s, 1072 waves
(In model scale: $H_s = 0.027$ m, $H_{max} = 0.048$ m, $T_m = 1.2$ s, $T_{H1/3} = 1.2$ s)

Frequency Domain Analysis:

Reflection = 0.1184, $H_{m0} = 0.41$ m, $T_p = 5.2$ s
(In model scale: $H_{m0} = 0.027$ m, $T_p = 1.3$ s)

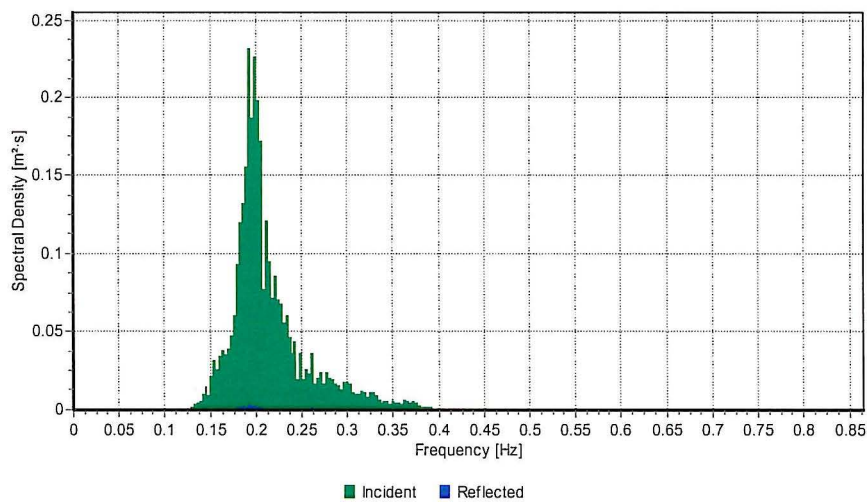

Test 3.2

Time Domain Analysis:

Reflection = 0.1113, $H_s = 0.80$ m, $H_{max} = 1.49$ m, $T_m = 4.6$ s, $T_{H1/3} = 4.8$ s, 1078 waves
(In model scale: $H_s = 0.053$ m, $H_{max} = 0.099$ m, $T_m = 1.2$ s, $T_{H1/3} = 1.2$ s)

Frequency Domain Analysis:

Reflection = 0.1027, $H_{m0} = 0.82$ m, $T_p = 5.0$ s
(In model scale: $H_{m0} = 0.055$ m, $T_p = 1.3$ s)

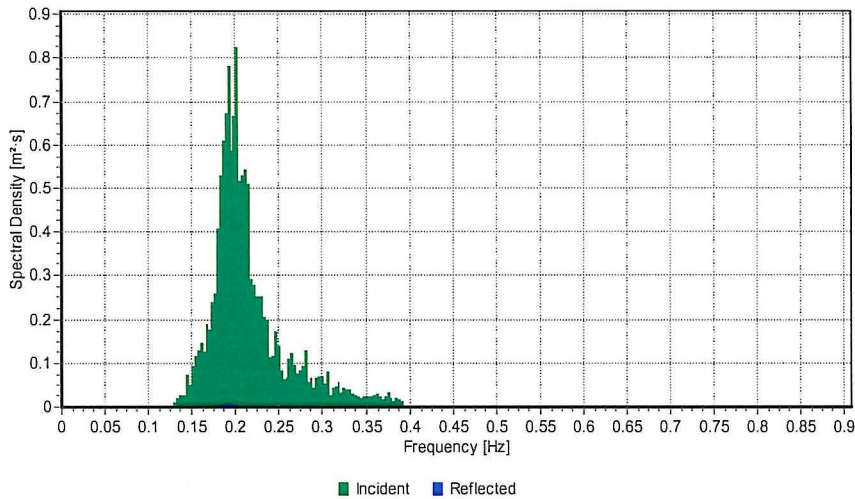

Test 3.3

Time Domain Analysis:

Reflection = 0.1125, $H_s = 1.32$ m, $H_{max} = 2.68$ m, $T_m = 4.7$ s, $T_{H1/3} = 4.9$ s, 1062 waves
(In model scale: $H_s = 0.088$ m, $H_{max} = 0.179$ m, $T_m = 1.2$ s, $T_{H1/3} = 1.3$ s)

Frequency Domain Analysis:

Reflection = 0.0911, $H_{m0} = 1.37$ m, $T_p = 5.0$ s
(In model scale: $H_{m0} = 0.091$ m, $T_p = 1.3$ s)

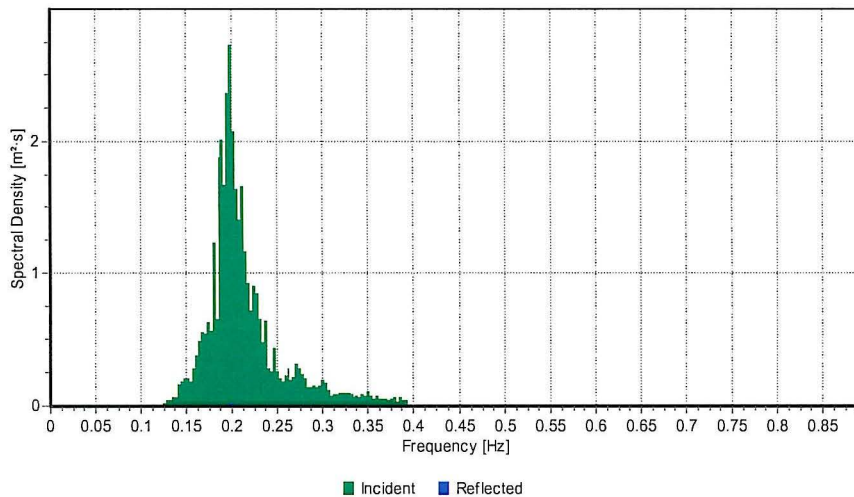

Test 3.4

Time Domain Analysis:

Reflection = 0.2056, $H_s = 0.46$ m, $H_{max} = 0.83$ m, $T_m = 6.9$ s, $T_{H1/3} = 7.7$ s, 1163 waves
 (In model scale: $H_s = 0.031$ m, $H_{max} = 0.055$ m, $T_m = 1.8$ s, $T_{H1/3} = 2.0$ s)

Frequency Domain Analysis:

Reflection = 0.1998, $H_{m0} = 0.47$ m, $T_p = 8.1$ s
 (In model scale: $H_{m0} = 0.031$ m, $T_p = 2.1$ s)

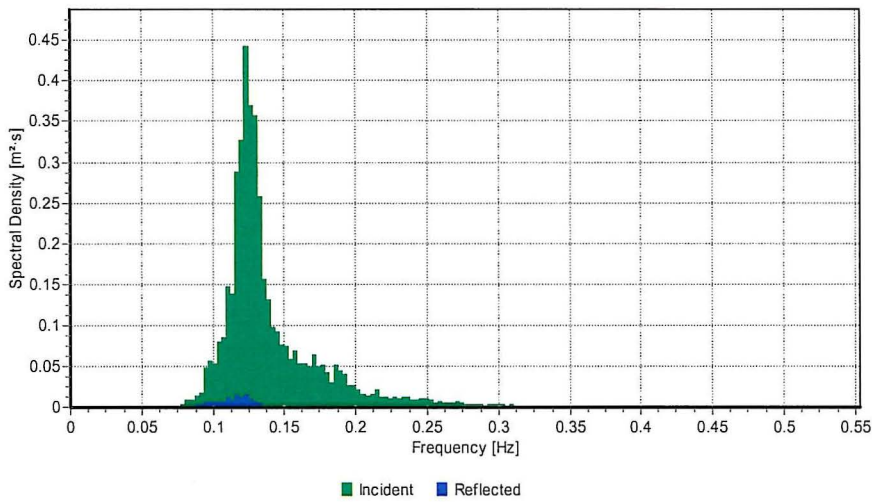

Test 3.5

Time Domain Analysis:

Reflection = 0.2182, $H_s = 0.95$ m, $H_{max} = 1.57$ m, $T_m = 7.0$ s, $T_{H1/3} = 7.8$ s, 1144 waves
 (In model scale: $H_s = 0.063$ m, $H_{max} = 0.104$ m, $T_m = 1.8$ s, $T_{H1/3} = 2.0$ s)

Frequency Domain Analysis:

Reflection = 0.2103, $H_{m0} = 0.97$ m, $T_p = 7.9$ s
 (In model scale: $H_{m0} = 0.065$ m, $T_p = 2.0$ s)

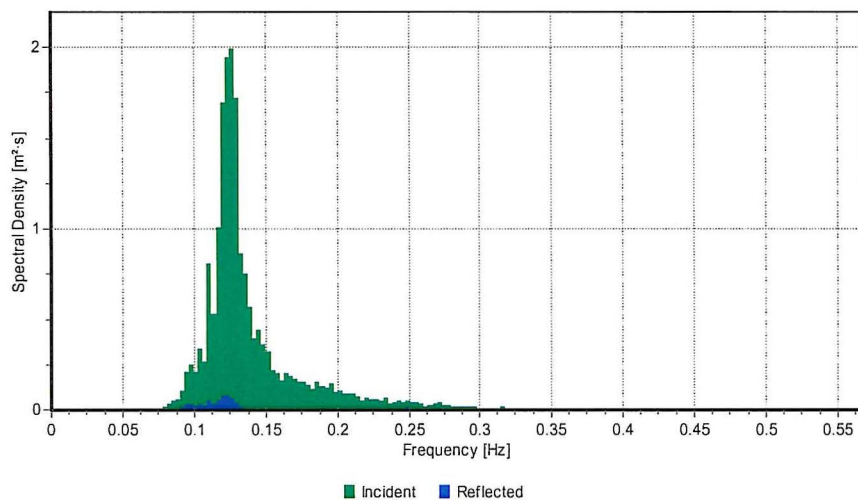

Test 3.6

Time Domain Analysis:

Reflection = 0.2222, $H_s = 1.55$ m, $H_{max} = 2.87$ m, $T_m = 6.9$ s, $T_{H1/3} = 7.6$ s, 1172 waves
 (In model scale: $H_s = 0.103$ m, $H_{max} = 0.191$ m, $T_m = 1.8$ s, $T_{H1/3} = 2.0$ s)

Frequency Domain Analysis:

Reflection = 0.2123, $H_{m0} = 1.62$ m, $T_p = 8.1$ s
 (In model scale: $H_{m0} = 0.108$ m, $T_p = 2.1$ s)

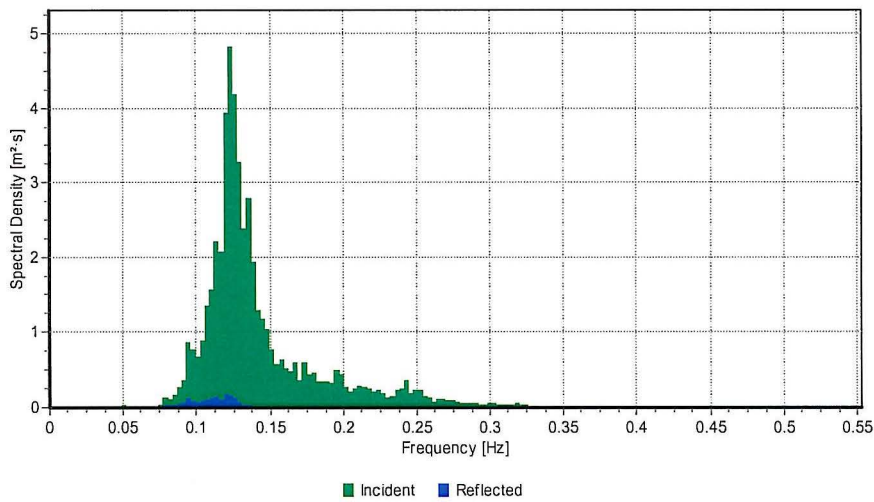

Test 3.7

Time Domain Analysis:

Reflection = 0.4195, $H_s = 0.44$ m, $H_{max} = 0.77$ m, $T_m = 9.0$ s, $T_{H1/3} = 10.1$ s, 1187 waves
 (In model scale: $H_s = 0.029$ m, $H_{max} = 0.052$ m, $T_m = 2.3$ s, $T_{H1/3} = 2.6$ s)

Frequency Domain Analysis:

Reflection = 0.418, $H_{m0} = 0.46$ m, $T_p = 10.6$ s
 (In model scale: $H_{m0} = 0.031$ m, $T_p = 2.7$ s)

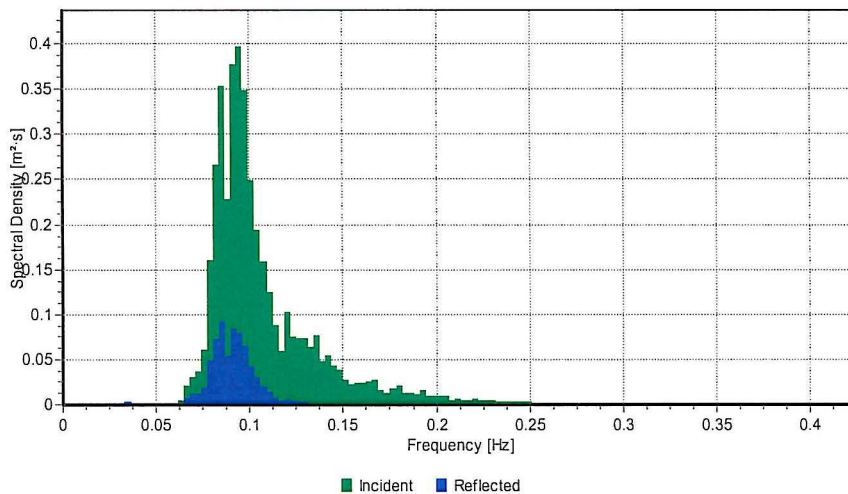

Test 3.8

Time Domain Analysis:

Reflection = 0.4004, $H_s = 0.86$ m, $H_{max} = 1.62$ m, $T_m = 9.0$ s, $T_{H1/3} = 10.2$ s, 1183 waves
 (In model scale: $H_s = 0.057$ m, $H_{max} = 0.108$ m, $T_m = 2.3$ s, $T_{H1/3} = 2.6$ s)

Frequency Domain Analysis:

Reflection = 0.402, $H_{m0} = 0.89$ m, $T_p = 10.6$ s
 (In model scale: $H_{m0} = 0.059$ m, $T_p = 2.7$ s)

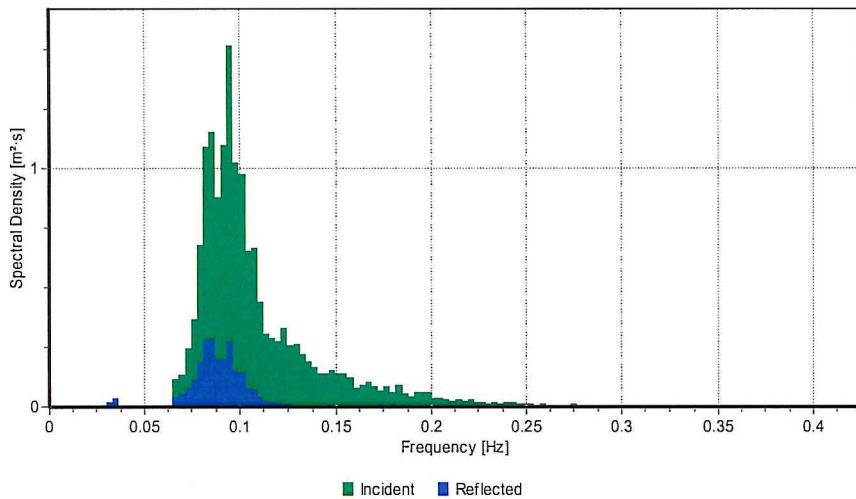

Test 3.9

Time Domain Analysis:

Reflection = 0.3551, $H_s = 1.04$ m, $H_{max} = 2.45$ m, $T_m = 6.9$ s, $T_{H1/3} = 8.5$ s, 1548 waves
 (In model scale: $H_s = 0.070$ m, $H_{max} = 0.164$ m, $T_m = 1.8$ s, $T_{H1/3} = 2.2$ s)

Frequency Domain Analysis:

Reflection = 0.329, $H_{m0} = 1.12$ m, $T_p = 10.6$ s
 (In model scale: $H_{m0} = 0.074$ m, $T_p = 2.7$ s)

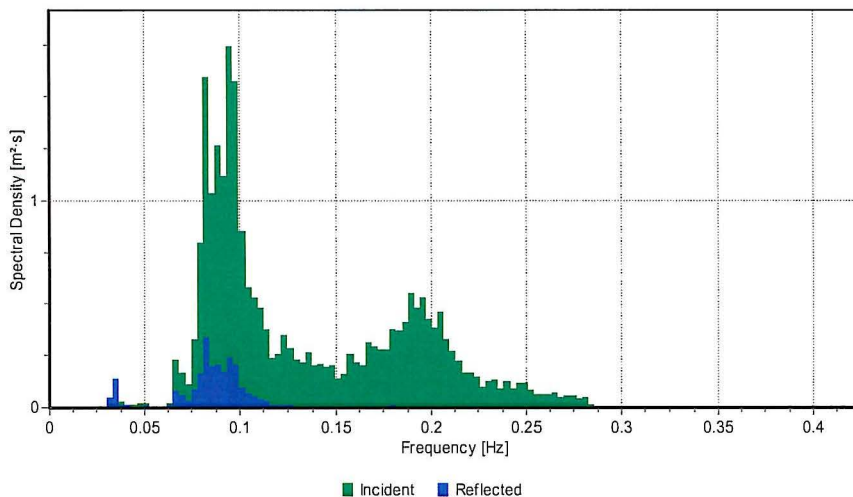

Test 3.10

Time Domain Analysis:

Reflection = 0.1273, $H_s = 0.41$ m, $H_{max} = 0.78$ m, $T_m = 4.6$ s, $T_{H1/3} = 4.9$ s, 1074 waves
 (In model scale: $H_s = 0.027$ m, $H_{max} = 0.052$ m, $T_m = 1.2$ s, $T_{H1/3} = 1.3$ s)

Frequency Domain Analysis:

Reflection = 0.119, $H_{m0} = 0.42$ m, $T_p = 5.0$ s
 (In model scale: $H_{m0} = 0.028$ m, $T_p = 1.3$ s)

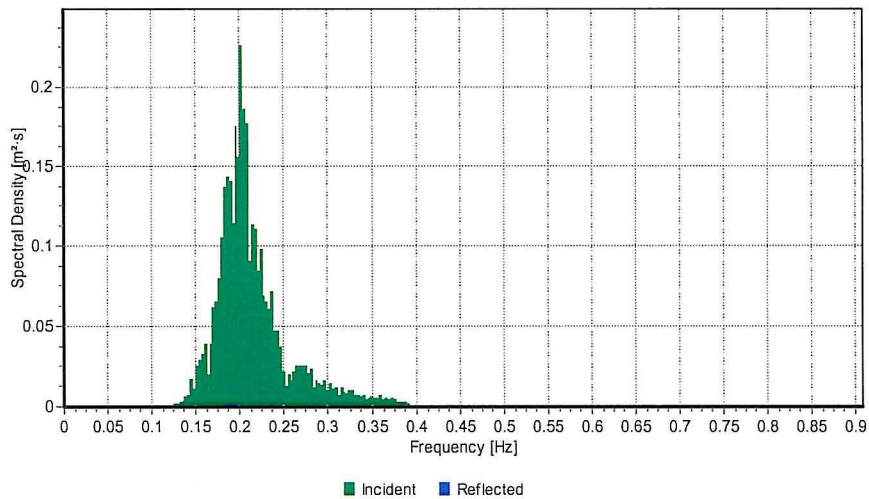

Test 3.11

Time Domain Analysis:

Reflection = 0.1811, $H_s = 0.46$ m, $H_{max} = 0.88$ m, $T_m = 6.8$ s, $T_{H1/3} = 7.7$ s, 1179 waves
 (In model scale: $H_s = 0.031$ m, $H_{max} = 0.059$ m, $T_m = 1.8$ s, $T_{H1/3} = 2.0$ s)

Frequency Domain Analysis:

Reflection = 0.1747, $H_{m0} = 0.49$ m, $T_p = 8.1$ s
 (In model scale: $H_{m0} = 0.033$ m, $T_p = 2.1$ s)

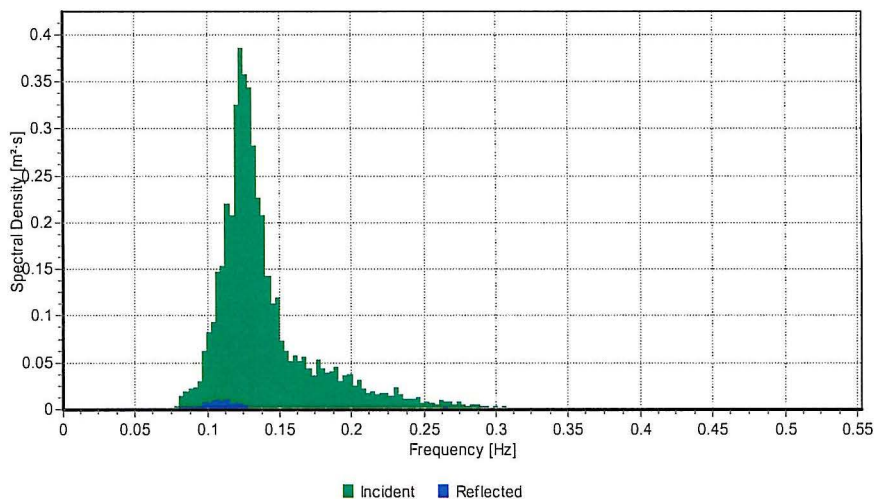

Test 3.12

Time Domain Analysis:

Reflection = 0.338, $H_s = 0.46$ m, $H_{max} = 0.82$ m, $T_m = 8.9$ s, $T_{H1/3} = 10.0$ s, 1198 waves
(In model scale: $H_s = 0.031$ m, $H_{max} = 0.055$ m, $T_m = 2.3$ s, $T_{H1/3} = 2.6$ s)

Frequency Domain Analysis:

Reflection = 0.3301, $H_{m0} = 0.48$ m, $T_p = 11.8$ s
(In model scale: $H_{m0} = 0.032$ m, $T_p = 3.0$ s)

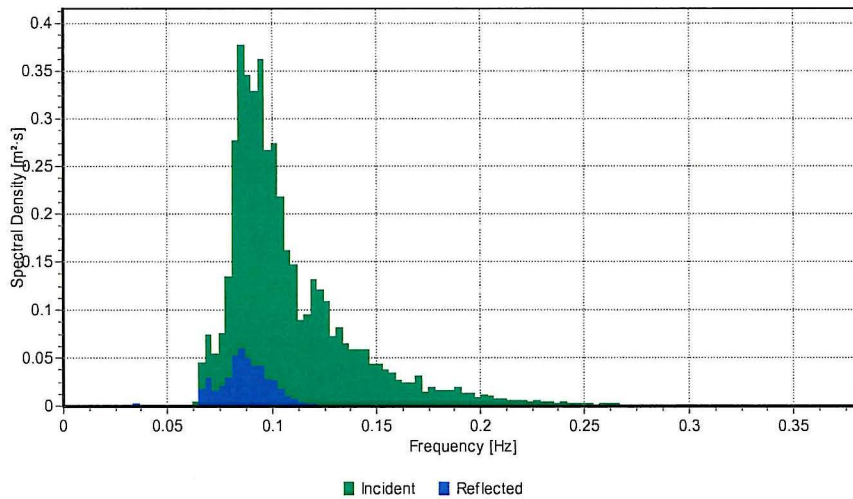

Annex 4 – Data Sheets for Testing of Alternative 2

Test 4.1

Time Domain Analysis:

Reflection = 0.2666, $H_s = 0.41$ m, $H_{max} = 0.75$ m, $T_m = 4.5$ s, $T_{H1/3} = 4.8$ s, 1109 waves
(In model scale: $H_s = 0.027$ m, $H_{max} = 0.050$ m, $T_m = 1.1$ s, $T_{H1/3} = 1.3$ s)

Frequency Domain Analysis:

Reflection = 0.239, $H_{m0} = 0.43$ m, $T_p = 5.1$ s
(In model scale: $H_{m0} = 0.028$ m, $T_p = 1.3$ s)

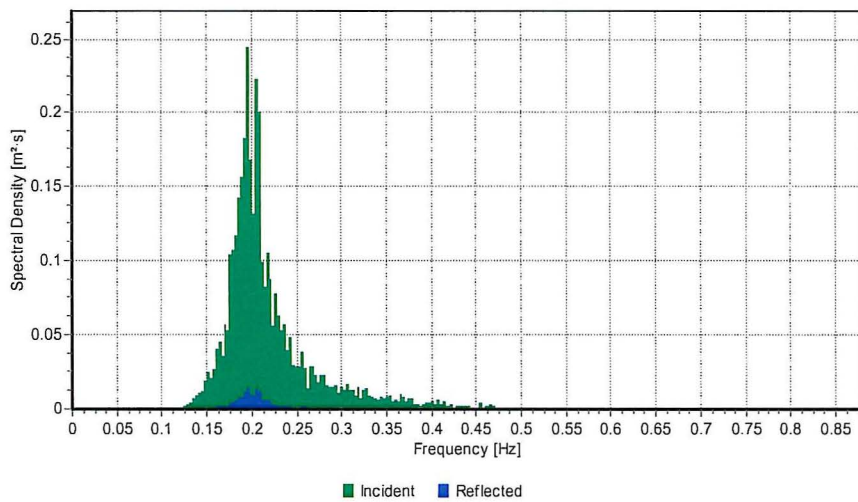

Test 4.2

Time Domain Analysis:

Reflection = 0.2059, $H_s = 0.81$ m, $H_{max} = 1.47$ m, $T_m = 4.6$ s, $T_{H1/3} = 4.8$ s, 1081 waves
 (In model scale: $H_s = 0.054$ m, $H_{max} = 0.098$ m, $T_m = 1.2$ s, $T_{H1/3} = 1.2$ s)

Frequency Domain Analysis:

Reflection = 0.2011, $H_{m0} = 0.82$ m, $T_p = 5.1$ s
 (In model scale: $H_{m0} = 0.055$ m, $T_p = 1.3$ s)

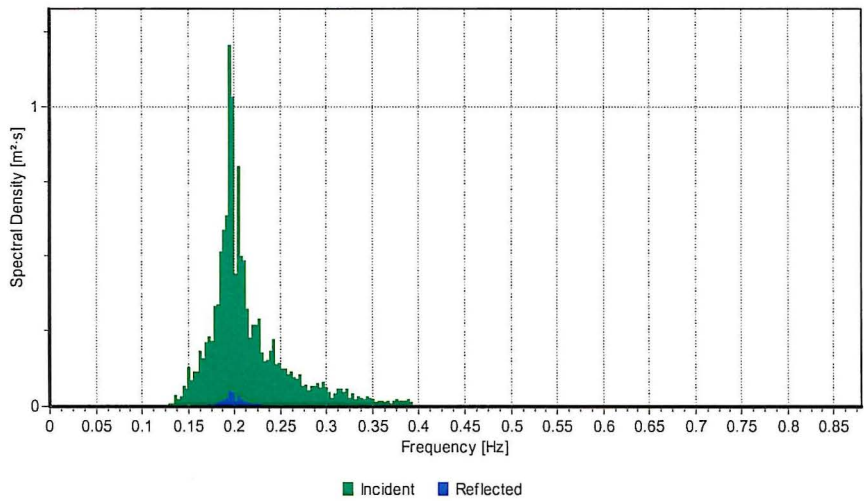

Test 4.3

Time Domain Analysis:

Reflection = 0.1695, $H_s = 1.44$ m, $H_{max} = 2.97$ m, $T_m = 4.5$ s, $T_{H1/3} = 4.8$ s, 1091 waves
 (In model scale: $H_s = 0.096$ m, $H_{max} = 0.198$ m, $T_m = 1.2$ s, $T_{H1/3} = 1.2$ s)

Frequency Domain Analysis:

Reflection = 0.1406, $H_{m0} = 1.46$ m, $T_p = 5.0$ s
 (In model scale: $H_{m0} = 0.097$ m, $T_p = 1.3$ s)

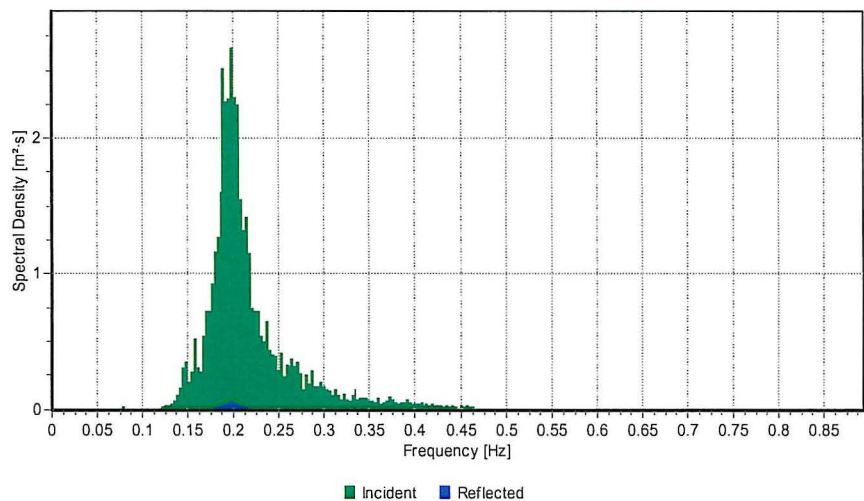

Test 4.4

Time Domain Analysis:

Reflection = 0.4095, $H_s = 0.45$ m, $H_{max} = 0.96$ m, $T_m = 6.9$ s, $T_{H1/3} = 7.7$ s, 1162 waves
(In model scale: $H_s = 0.030$ m, $H_{max} = 0.064$ m, $T_m = 1.8$ s, $T_{H1/3} = 2.0$ s)

Frequency Domain Analysis:

Reflection = 0.3919, $H_{m0} = 0.47$ m, $T_p = 8.1$ s
(In model scale: $H_{m0} = 0.032$ m, $T_p = 2.1$ s)

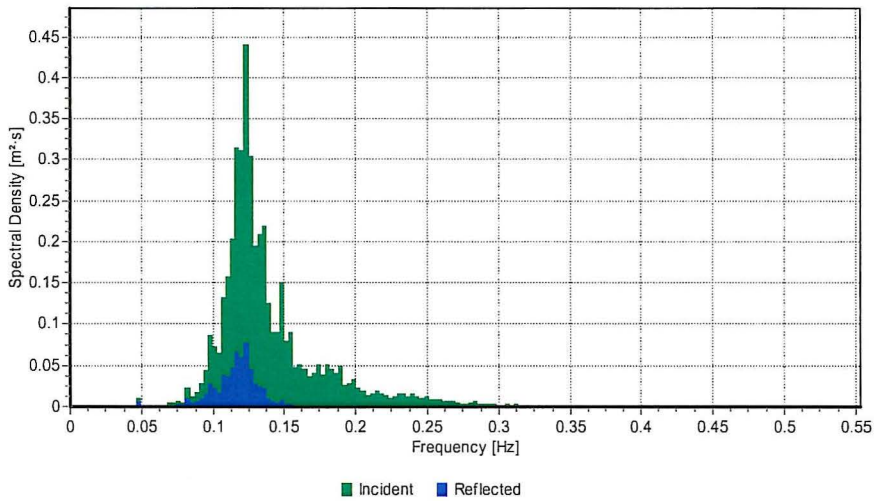

Test 4.5

Time Domain Analysis:

Reflection = 0.3812, $H_s = 0.82$ m, $H_{max} = 1.73$ m, $T_m = 6.9$ s, $T_{H1/3} = 7.6$ s, 1157 waves
(In model scale: $H_s = 0.055$ m, $H_{max} = 0.115$ m, $T_m = 1.8$ s, $T_{H1/3} = 2.0$ s)

Frequency Domain Analysis:

Reflection = 0.3616, $H_{m0} = 0.86$ m, $T_p = 8.1$ s
(In model scale: $H_{m0} = 0.057$ m, $T_p = 2.1$ s)

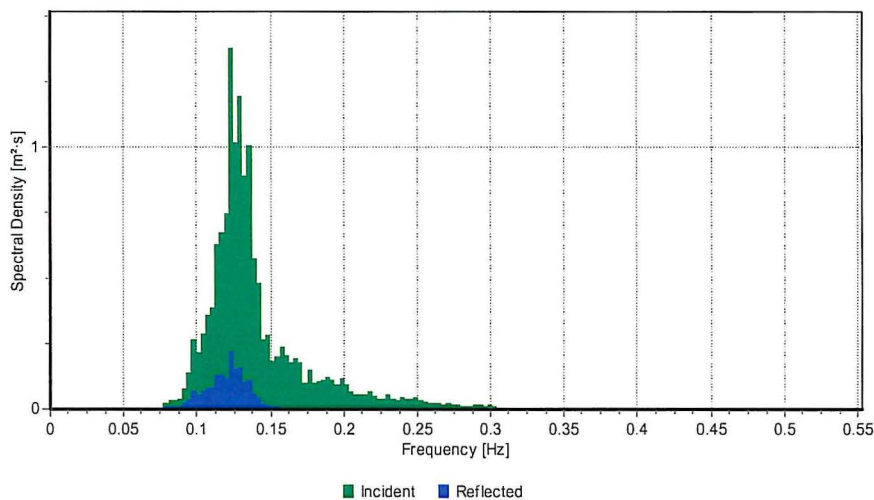

Test 4.6

Time Domain Analysis:

Reflection = 0.327, $H_s = 1.54$ m, $H_{max} = 2.66$ m, $T_m = 6.9$ s, $T_{H1/3} = 7.6$ s, 1165 waves
 (In model scale: $H_s = 0.102$ m, $H_{max} = 0.177$ m, $T_m = 1.8$ s, $T_{H1/3} = 2.0$ s)

Frequency Domain Analysis:

Reflection = 0.3183, $H_{m0} = 1.60$ m, $T_p = 8.1$ s
 (In model scale: $H_{m0} = 0.107$ m, $T_p = 2.1$ s)

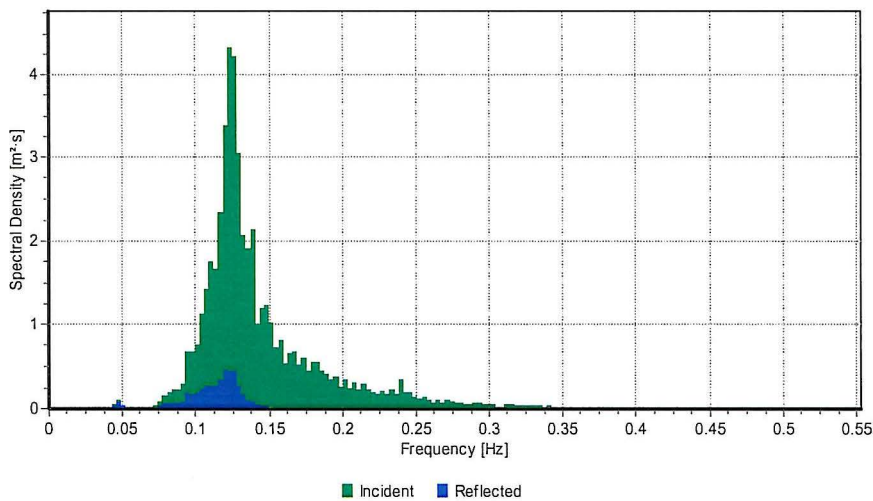

Test 4.7

Time Domain Analysis:

Reflection = 0.5439, $H_s = 0.45$ m, $H_{max} = 0.92$ m, $T_m = 9.0$ s, $T_{H1/3} = 10.0$ s, 1186 waves
 (In model scale: $H_s = 0.030$ m, $H_{max} = 0.062$ m, $T_m = 2.3$ s, $T_{H1/3} = 2.6$ s)

Frequency Domain Analysis:

Reflection = 0.5299, $H_{m0} = 0.47$ m, $T_p = 10.2$ s
 (In model scale: $H_{m0} = 0.031$ m, $T_p = 2.6$ s)

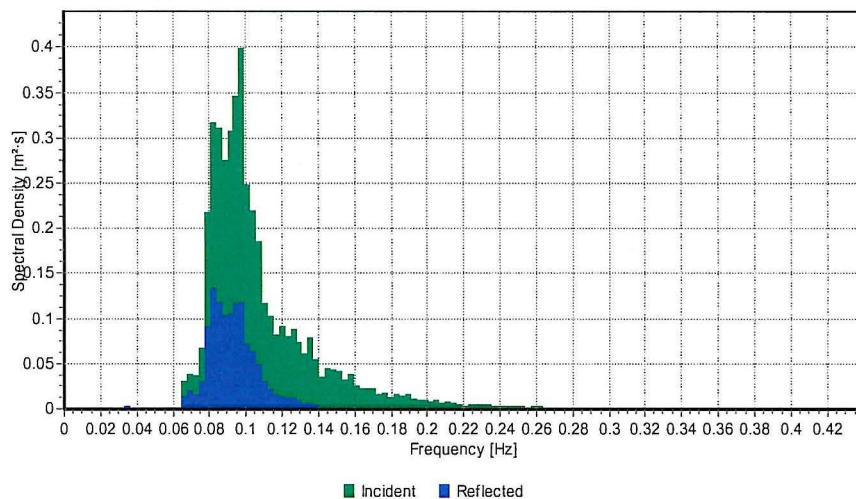

Test 4.8

Time Domain Analysis:

Reflection = 0.5603, $H_s = 0.90$ m, $H_{max} = 1.84$ m, $T_m = 9.0$ s, $T_{H1/3} = 10.4$ s, 1183 waves
 (In model scale: $H_s = 0.060$ m, $H_{max} = 0.122$ m, $T_m = 2.3$ s, $T_{H1/3} = 2.7$ s)

Frequency Domain Analysis:

Reflection = 0.5444, $H_{m0} = 0.95$ m, $T_p = 10.6$ s
 (In model scale: $H_{m0} = 0.063$ m, $T_p = 2.7$ s)

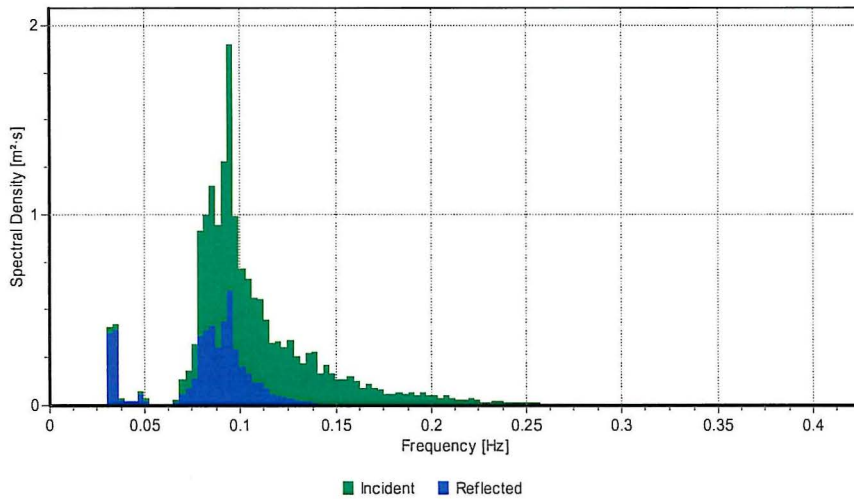

Test 4.9

Time Domain Analysis:

Reflection = 0.5033, $H_s = 1.52$ m, $H_{max} = 2.51$ m, $T_m = 8.8$ s, $T_{H1/3} = 10.0$ s, 1215 waves
 (In model scale: $H_s = 0.101$ m, $H_{max} = 0.167$ m, $T_m = 2.3$ s, $T_{H1/3} = 2.6$ s)

Frequency Domain Analysis:

Reflection = 0.4913, $H_{m0} = 1.59$ m, $T_p = 10.6$ s
 (In model scale: $H_{m0} = 0.106$ m, $T_p = 2.7$ s)

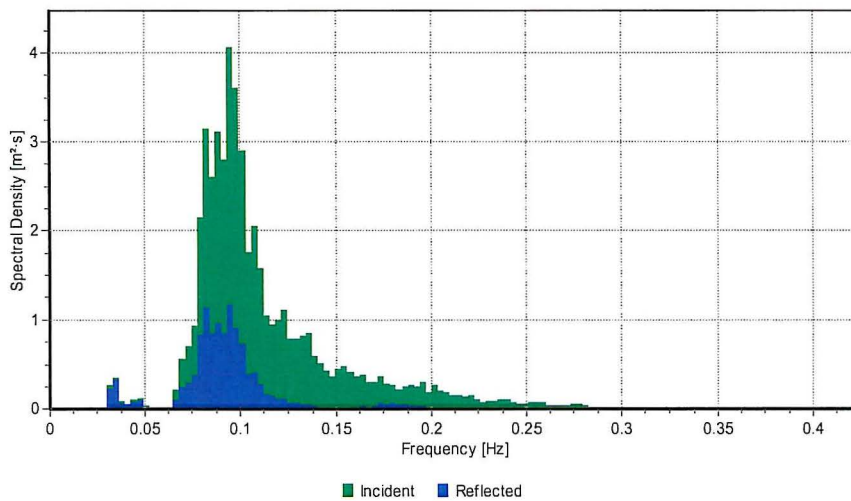

Test 4.10

Time Domain Analysis:

Reflection = 0.1626, $H_s = 0.40$ m, $H_{max} = 0.71$ m, $T_m = 4.5$ s, $T_{H1/3} = 4.9$ s, 1092 waves
(In model scale: $H_s = 0.026$ m, $H_{max} = 0.047$ m, $T_m = 1.2$ s, $T_{H1/3} = 1.3$ s)

Frequency Domain Analysis:

Reflection = 0.1226, $H_{m0} = 0.41$ m, $T_p = 5.3$ s
(In model scale: $H_{m0} = 0.027$ m, $T_p = 1.4$ s)

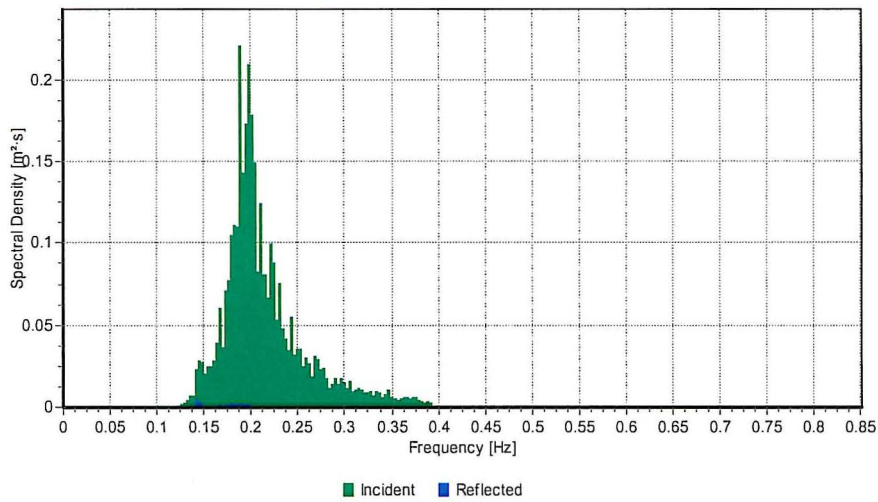

Test 4.11

Time Domain Analysis:

Reflection = 0.2754, $H_s = 0.48$ m, $H_{max} = 0.85$ m, $T_m = 7.0$ s, $T_{H1/3} = 7.7$ s, 1151 waves
(In model scale: $H_s = 0.032$ m, $H_{max} = 0.057$ m, $T_m = 1.8$ s, $T_{H1/3} = 2.0$ s)

Frequency Domain Analysis:

Reflection = 0.2613, $H_{m0} = 0.50$ m, $T_p = 8.1$ s
(In model scale: $H_{m0} = 0.033$ m, $T_p = 2.1$ s)

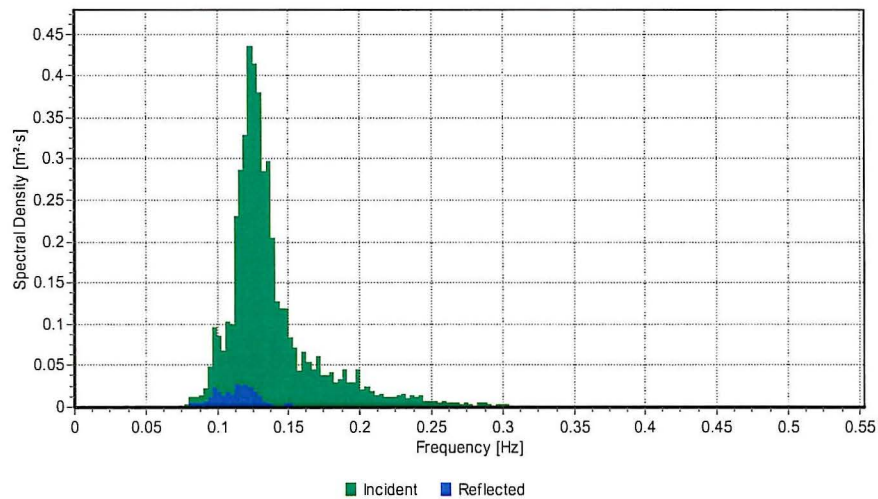

Test 4.12

Time Domain Analysis:

Reflection = 0.4963, $H_s = 0.45$ m, $H_{max} = 0.84$ m, $T_m = 8.9$ s, $T_{H1/3} = 10.0$ s, 1207 waves
(In model scale: $H_s = 0.030$ m, $H_{max} = 0.056$ m, $T_m = 2.3$ s, $T_{H1/3} = 2.6$ s)

Frequency Domain Analysis:

Reflection = 0.4831, $H_{m0} = 0.47$ m, $T_p = 10.2$ s
(In model scale: $H_{m0} = 0.032$ m, $T_p = 2.6$ s)

