



Aalborg Universitet

AALBORG UNIVERSITY
DENMARK

Impact of Cyclic Prefix length on OFDM system Capacity

Rom, Christian; Sørensen, Troels Bundgaard; Mogensen, Preben Elgaard; Vejlggaard, Benny

Published in:
Proceedings of WPMC '05

Publication date:
2005

Document Version
Publisher's PDF, also known as Version of record

[Link to publication from Aalborg University](#)

Citation for published version (APA):
Rom, C., Sørensen, T. B., Mogensen, P. E., & Vejlggaard, B. (2005). Impact of Cyclic Prefix length on OFDM system Capacity. In Proceedings of WPMC '05 (pp. 1871-1875)

General rights

Copyright and moral rights for the publications made accessible in the public portal are retained by the authors and/or other copyright owners and it is a condition of accessing publications that users recognise and abide by the legal requirements associated with these rights.

- ? Users may download and print one copy of any publication from the public portal for the purpose of private study or research.
- ? You may not further distribute the material or use it for any profit-making activity or commercial gain
- ? You may freely distribute the URL identifying the publication in the public portal ?

Take down policy

If you believe that this document breaches copyright please contact us at vbn@aub.aau.dk providing details, and we will remove access to the work immediately and investigate your claim.

Impact of Cyclic Prefix length on OFDM system Capacity

Christian Rom, Troels B. Sørensen,
Preben Mogensen

Department of Communication Technology,
Aalborg University,
Niels Jernes vej 12, DK9220 Aalborg, Denmark
{chr, tbs, pm}@kom.aau.dk,

Benny Vejlgaard

Infineon Technologies Wireless Denmark,
Alfred Nobels Vej 25,
DK9220 Aalborg, Denmark
bv@dwd.dk

Abstract— This paper is a study on the impact of the Cyclic Prefix (CP) length on the downlink Capacity in a base-band synchronized SISO-OFDM context. To measure this impact, the capacity, measured in bits per second per hertz, is chosen as quality parameter. The study shows how the lengthening of the CP affects Spectral Efficiency Loss (SEL) and Signal to Interference and Noise Ratio (SINR). SINR can be mapped into Capacity using Shannons formula. The optimum CP length is defined as the one that maximises the Capacity for a given set of system parameters. The parameters studied in this paper are: 1) the useful OFDM symbol duration, 2) the Signal to Noise Ratio (SNR) at the receiver and 3) the channel Power Delay Profile (PDP). Depending on the values of these parameters different optimum CP lengths are obtained. For a system using only one value of CP length we suggest an optimum value to be 4 μ s for an OFDM symbol length of 40 μ s and 6 μ s for an OFDM symbol length of 80 μ s.

Key words: Cyclic Prefix length, Power Delay Profiles, System Capacity, OFDM

1. INTRODUCTION

Orthogonal Frequency Division Multiplex (OFDM) has been widely studied for communication systems such as Wireless LAN's or MAN's [5] and is generally believed to be an efficient transmission technology in multipath [2]. OFDM is currently a serious candidate to become the radio interface for the downlink in UTRA/UTRAN Long Term Evolution (LTE) [3]. A CP is generally inserted in OFDM transmission to combat interference resulting from the multipath nature of the physical channel. If the CP length is larger than the Channel Impulse Response (CIR) length, all multipath energy resulting from delayed replicas of the signal is constructively recovered [2]. The CP has no influence on the interference resulting from mobility and the resulting Doppler shift [1]. Therefore, arbitrarily, the effect of Doppler spectrum is disregarded in this paper.

The introduction of CP has the drawback of reducing the overall system capacity in an irreversible manner. This reduction can be expressed through the Spectral Efficiency Loss (SEL): $SEL = T_g / T_{gs}$, with T_g

being the CP length, T_s the useful symbol length and $T_{gs} = T_g + T_s$ the total OFDM symbol length.

It can be seen that the SEL does not only depend on T_g but also on T_s . If T_g is fixed, the SEL diminishes when T_s is increased. During this study T_s will be fixed to a few chosen values inspired from previous studies [5], [6].

On the other hand, as CP covers more and more of the PDP, it increases the SINR, thus enhancing the overall performance of the system. The other advantage when the CP length is larger than the maximum excess delay, is that optimum performance can be achieved with a Single Tap Equalizer (STE) [4]. From a complexity point of view this STE has interesting properties and is therefore adopted in this paper. System level CP length studies have previously been conducted but without focusing precisely on variation of PDP's. In [7] for instance, CP length was studied in connection with synchronization.

Efficient adaptive CP length has recently been proposed by Lim [9]. The drawback of such a solution is increased signalling overhead. In this paper we propose to find one constant CP length to cover all scenarios, and thereby simplifying the receiver design.

In Section 2 the system model will be described. In Section 3 the considered SINR calculation methods and their results will be presented. Following, the simulated capacity results will be given in Section 4. A Discussion of the optimum CP length is conducted in Section 5 and finally we conclude this paper in Section 6.

2. System Model

An OFDM analytical model has been derived from Fig. 1 assuming:

- The maximum excess delay is smaller than T_{gs}
- The channel PDP is sample spaced according to the receiver sampling rate
- The receiver is perfectly synchronized with the first tap of the impulse response

The signal at sample level after FFT is expressed as by:

$$z_m[l] = \sum_{k=0}^{N_g-1} (C_{0_m}[l, k] \cdot d_m[k] + C_{1_{m-1}}[l, k] \cdot d_{m-1}[k]) + W_m[l] \quad (1)$$

With, $d_m[k]$ being the k^{th} data symbol and $W_m[l]$ the l^{th} sample of a white noise process, observed in the m^{th} signaling interval. The number of samples in the full OFDM symbol is N_{gs} , in the Cyclic Prefix N_s , and in the useful OFDM symbol is N_g . Each correlation coefficient can be described by:

$$C0_m[l, k] = \sum_{n=0}^{N_{gs}-1} \tilde{\psi}_{m,l}^*[n] \cdot \sum_{i=0}^n a_{m,i}[n-i] \cdot \psi_{m,k}[n-i] \quad (2)$$

and:

$$C1_m[l, k] = \sum_{n=0}^{N_{gs}-2} \tilde{\psi}_{m,l}^*[n] \cdot \sum_{i=n+1}^{N_{gs}-1} a_{m,i}[N_{gs}+n-i] \cdot \psi_{m,k}[N_{gs}+n-i] \quad (3)$$

$\psi_{m,k}[n]$ is the k^{th} orthogonality vector including CP at

$$\text{sample time } n, \psi_{m,k}[n] = \frac{1}{\sqrt{N_s}} \cdot e^{j2\pi k \left(\frac{n-N_g}{N_s} \right)},$$

$$\tilde{\psi}_{m,l}[n] = \psi_{m,l}[n] \text{ when } N_g \leq n < N_{gs}, \text{ else}$$

$$\tilde{\psi}_{m,l}[n] = 0.$$

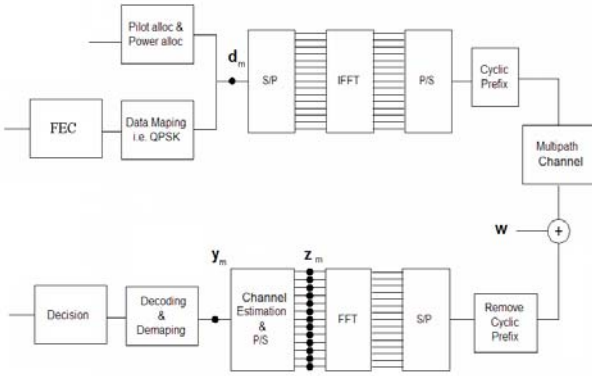

Figure 1: System Block diagram.

$a_{m,i}[n]$ is the i^{th} complex tap coefficient of the channel impulse response at the given instant n in signaling interval m .

In order to decode the data after the FFT, a “channel matching” is performed by:

$$y_m[l] = C0_m^*[l, l] \cdot z_m[l] \quad (4)$$

This channel matching is called Single Tap Equalizer (STE).

3. SINR calculation methods

In the following two methods for evaluating SINR are considered. In the first method, a Monte Carlo approach is considered using the analytic model previously derived. In the second method, an analytic approach inspired from [1] and [7] is given. The two methods are then compared and used to generate SINR results for the presented PDP's. For both methods the same general SINR per subcarrier formula is given by:

$$SINR = \frac{P_s}{P_i + \sigma_w^2} \quad (5)$$

where P_s is the “useful” signal power, P_i is the interference power, and σ_w^2 is the variance of the additive white gaussian noise. All powers are expressed per subcarrier.

3.1. Monte Carlo based method

The Monte Carlo based SINR method is evaluated on the signal z_m after the FFT at the receiver. The “desired” signal is given by:

$$z_s[l] = C0_m[l, l] \cdot d_m[l] \quad (6)$$

The power of the “desired” signal is then estimated by:

$$P_s = E\{|z_s[l] - E(z_s[l])|^2\} \quad (7)$$

The interference is given by:

$$z_i[l] = z_m[l] - (z_s[l] + W_m[l]) \quad (8)$$

The power of the interfering signal is then estimated by:

$$P_i = E\{|z_i[l] - E(z_i[l])|^2\} \quad (9)$$

During the simulations the variance of the additive white gaussian noise is known.

3.2. Analytic method

In this section the “useful” signal and the interference signal are both calculated from a given PDP and a weighting function called “bias function” $C(\tau)$. This function was first used in [1] and extended for timing offset in [7]. In this paper the synchronicity assumption leads to the following definition:

$$C(\tau) = \begin{cases} 0, & \tau < 0 \\ 1, & 0 \leq \tau < T_g \\ \frac{(T_s - (\tau - T_g))}{T_s}, & T_g \leq \tau < T_{gs} \\ 0, & T_{gs} \leq \tau \end{cases} \quad (10)$$

We assume the channel PDP to have p taps with power $|a_i|^2$ at the i^{th} tap at delay τ_i .

The power of the “desired” signal is given by:

$$P_s = \sum_{i=1}^p C(\tau_i)^2 |a_i|^2 \quad (11)$$

The interference is given by:

$$P_i = \sum_{i=1}^p (1 - C(\tau_i)^2) |a_i|^2 \quad (12)$$

During all following we assume the channel to be normalized so that: $\sum_{i=1}^p a_i = 1$.

It is noted that both methods give the same SINR results within repeatability of the Monte Carlo simulations. Method 2 is adopted for the rest of this paper.

3.3. Power Delay Profiles considered

Three ITU profiles are considered for the PDPs and their characteristics are given in Table 1. T_{rms} is the root mean square delay spread of the considered profile, and τ is the considered tap delay.

Table 1: ITU PDP considered (delays are in nano sec, and powers are in dB relative to the strongest path)

Indoor B		Pedestrian B		Vehicular B	
Delay	Power	Delay	Power	Delay	Power
0	0	0	0	0	-2.5
100	-3.6	200	-0.9	300	0
200	-7.2	800	-4.9	8900	-12.8
300	-10.8	1200	-8.0	12900	-10.0
500	-18.0	2300	-7.8	17100	-25.2
700	-25.2	3700	-23.9	20000	-16.0
$T_{rms} = 100$		$T_{rms} = 750$		$T_{rms} = 4000$	

A common profile used in standardization [11] is the exp decaying PDP. Five profiles are chosen and their characteristics are described by Table 2 and by the following exponentially decayed power delay profile:

$$P_{exp}(\tau) = \frac{1}{T_{rms}} e^{\left(\frac{-\tau}{T_{rms}}\right)} \quad (13)$$

Table 2: Exponential decaying profiles, 40 taps

Profile name	Tap Spacing (ns)	T_{rms} (ns)
Exp100	40	100
Exp750	160	750
Exp1500	320	1500
Exp3000	640	3000
Exp4000	1000	4000

Finally, the Hilly Terrain profile, described in [10] with $T_{rms} = 3 \mu s$ will also be used.

In order to get an idea of the average distribution of T_{rms} values, the measurements in [7] are adopted. They are as follows:

In Suburban areas the median value of T_{rms} is of $0.55 \mu s$. However 5% of the time T_{rms} is larger than $2.71 \mu s$. In Urban areas the median value of T_{rms} is of $0.88 \mu s$, whereas 5% of the time T_{rms} is larger than $1.54 \mu s$.

4. Simulation Results

The focus of this study is to give insight on the choice of an optimal CP length. It is conducted under the assumption that the “useful” OFDM symbol length is considered limited below $160 \mu s$.

4.1. SINR for Varying CP length

Figure 2 shows the SINR power raise in dB as T_g is increasing. T_s is fixed to $40 \mu s$. Three ITU profiles have been chosen as well as three exponentially decaying profiles with the same T_{rms} . It can be seen by inspection that even though the T_{rms} are of equal value the SINR curves are different. This is especially true for the VehB and the Exp4000 profiles. From 0 to $7 \mu s$ the VehB lies above the Exp4000 curve. After $7 \mu s$ the curves are much similar.

For all curves the maximum SINR corresponding to the received SNR, is obtained when T_g exceeds the maximum excess delay.

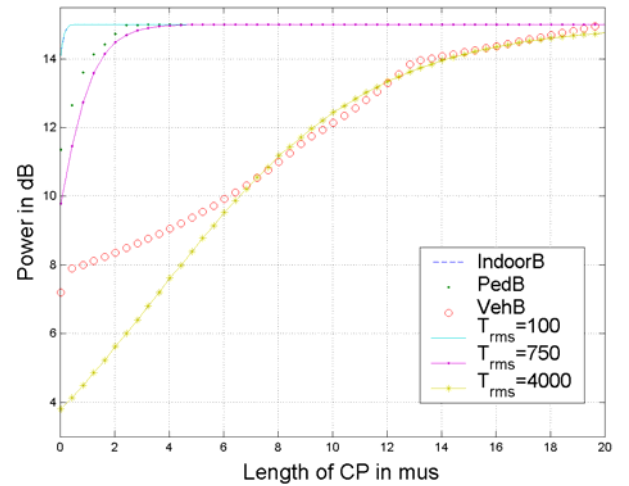

Figure 2: SINR vs. CP length for different PDP, $T_s = 40 \mu s$.

4.2. System CAPACITY results

Maximizing the SINR increases the receiver Bit Error Rate, but at the same time when the CP length is extended transmission time is lost in an irrecoverable manner. Therefore a System level approach is needed to take account of both effects. We use an approach similar to [7] where SINR is mapped to capacity in b/s/Hz through Shannons Capacity theorem. In doing this we account for a link adaptation loss α and a maximum bandwidth efficiency corresponding to 64QAM modulation. It follows that the capacity is given by:

$$C(T_g) = (1 - SEL) \cdot \min\{\log_2(1 + \alpha \cdot SINR(T_g)), 6\} \quad (14)$$

α is a fixed loss from the Shannon limit and is set to 0.4 for this study corresponding to the degradation of Link Adaptation used in [8].

4.2.1. Effect of SNR on CP length

The SINR defined earlier depends on the “desired” Signal to Noise Ratio (SNR) at the receiver. The SNR is being defined as equal to the SINR when the CP length is larger than the maximum excess delay of the channel impulse response. The impact of the SNR is studied in Figure 3. It is observed that the receiver is much more sensitive to the CP length at high SNR, whereas at low SNR its impact is almost negligible. I.e. at 31 dB there is a difference of 0.4 bit/s/Hz for T_g varying between 0 and 2 μ s, whereas at 1 dB the variation is less than 0.05 bit/s/Hz from 0 to 2 μ s. Therefore in the following only high SNR values between 15 to 20 dB are considered.

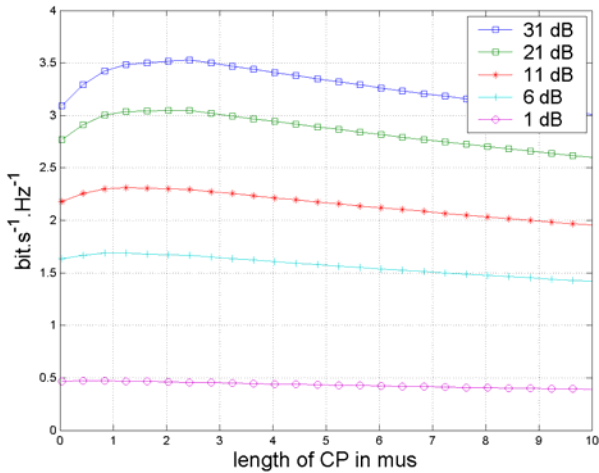

Figure 3: Capacity vs. CP length for different received signal powers, PDP=PedB, $T_s = 40 \mu$ s.

4.2.2. Effect of the “useful” symbol duration on CP length

The length of the “useful” OFDM symbol T_s is studied in Figure 4 where the capacity versus the CP length is plotted for T_s varying from 10 μ s to 160 μ s and the PDP is PedB.

T_s has only little influence on the optimal CP length. However the longer T_s , the less sensitive the Capacity is to a CP length that is too short or too long.

I.e. if $T_g = 8 \mu$ s then with $T_s = 160 \mu$ s the capacity is reduced by only 0.1 bit/s/Hz from the maximum achievable performance. Whereas with $T_s = 10 \mu$ s the loss would be more than 0.7 bit/s/Hz.

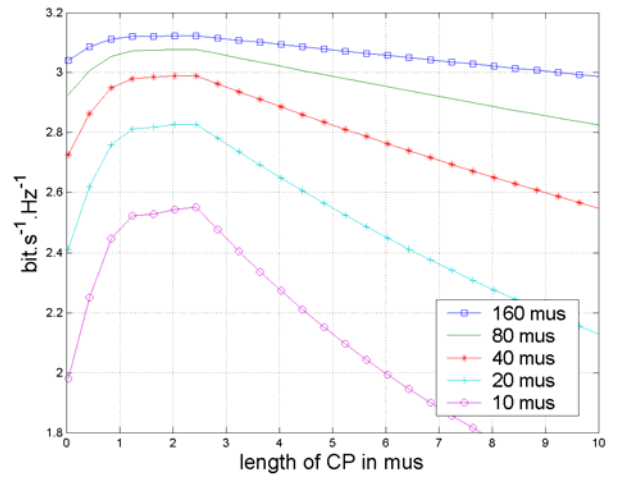

Figure 4: Capacity vs. CP length for different useful OFDM symbol lengths, PDP=PedB, SNR=20dB.

4.2.3. Effect of the Power Delay Profile on CP length

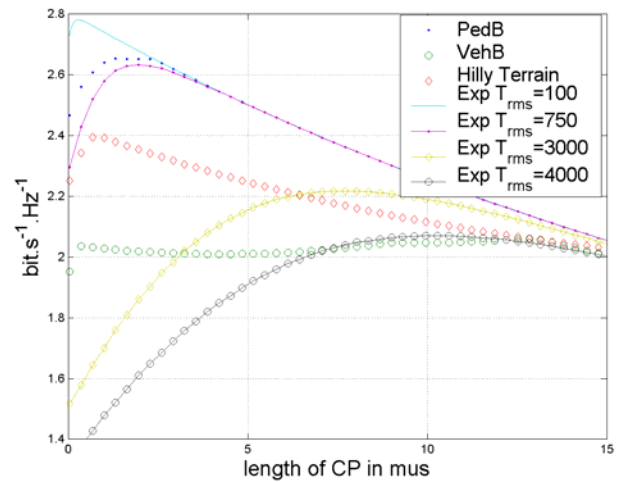

Figure 5: Capacity vs. CP length for an exp. PDP with increasing T_{rms} , SNR=15dB, $T_s = 40 \mu$ s.

In Figure 5, exponentially decaying PDPs are plotted with 4 different T_{rms} . It is noted that the optimal CP length increases as T_{rms} increases. This result has often been used as a design guideline in common literature. However when comparing HT and VehB of respectively T_{rms} of 3000 and 4000 ns with their exp. dec. counterparts at same T_{rms} . It is noted that the optimal CP length can significantly vary from profile to profile, i.e. for the HT PDP the optimum T_g is of 1 μ s, but for the exp. dec. PDP of $T_{rms}=3 \mu$ s it is of 7.5 μ s. Hence linear dependency is not always true between optimal CP length and T_{rms} and the entire PDP must be considered.

5. DISCUSSION

In order to avoid signaling overhead to control a variable CP length, one single constant CP value is preferable. This length should give the best average performance. The highest Capacity is achieved with a 1 path PDP. A CP length not covering the full CIR will always lead to a loss that can be divided in two components: the loss due to SEL and the loss due to interference. The choice of a single CP length will be a tradeoff between how much permanent SEL the system can accept and how much "worst-case interference" loss can be allowed. This tradeoff can be seen on Figure 6.

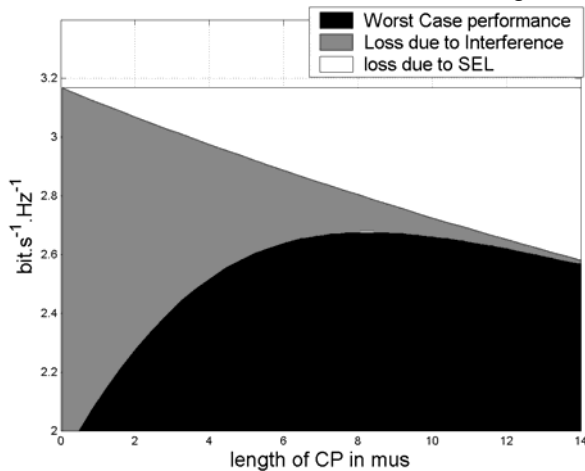

Figure 6: On the efficiency of the CP to cope with multipath, Exp3000, SNR=20dB, $T_s = 60\mu$ s.

We assume that the Exp3000 is the worst-case scenario. A CP length of 4 μ s will give a Capacity of 2,5 bit/s/Hz whereas a CP length of 8 μ s will perform better with a Capacity of 2,7 bit/s/Hz. However in the case Exp750 the CP of 4 μ s gives a capacity of 3 bit/s/Hz and the CP of 8 μ s will perform worse with a capacity of 2.8 bit/s/Hz. T_{rms} is smaller that 2.71 μ s 95% of the time and in average would be of 0.5 μ s to .9 μ s, as mentioned subsection 3.3. Therefore we recommend a CP length of

around 4 μ s for a $T_s=40 \mu$ s and around 6 μ s for a $T_s=80 \mu$ s.

6. CONCLUSIONS

This paper studied the impact of cyclic prefix on capacity, in the context of a synchronized SISO-OFDM model. Two different SINR models were proposed and proved to give same results. Capacity was adopted as quality measure to determine the optimal CP length. It was shown in the study that the received SNR increased the sensitivity of the Capacity to the CP length. Only high SNR values should be adopted to study this parameter. It was also shown that the duration of the "useful" OFDM symbol didn't impact the optimal CP length significantly. However it impacted the capacity loss due to a CP being too long or too short. Therefore the "useful" OFDM symbol should be as long as the system design allows. The RMS delay spread of a PDP is not a sufficient statistic to determine the optimal CP length. The whole PDP of the channel should be considered. Large variations of optimal CP length can be observed for PDPs having equal RMS delay spread. We ended by suggesting a CP length of 4 μ s or 6 μ s depending on the length of the useful OFDM symbol being 40 μ s or 80 μ s respectively.

REFERENCES

- [1] H. Steendam, M. Moenclaey, "Analysis and Optimization of the Performance of OFDM on Frequency-Selective Time-Selective Fading Channels," *IEEE Trans. Commun.* vol. 47, pp. 1811-1819, dec. 1999
- [2] J. A. C. Bingham, "Multicarrier Modulation for Data Transmission: An Idea Whose Time Has Come," *IEEE Commun. Mag.* vol. 31, pp 5-14, May 1990.
- [3] "Approved Study Item on Evolved UTRA and UTRAN", 3GPP TSG RAN RP-040431, Dec, 2004, Athens Greece
- [4] J. L. Seoane, S. K. Wilson, S. Gelfand, "Analysis of Intertone and Interblock Interference in OFDM whe the length of the Cyclic Prefix is shorter than the length of the Channel Impulse Response," *Globecom 97*, Pheonix Arizona, Nov 1997.
- [5] H. Yaghoobi, "Scalable OFDMA Physical Layer in IEEE 802.16 Wireless MAN ", Intel Technology Journal, Volume 8, Issue 3, 2004.
- [6] F. Tufvesson, T. Maseng "Optimization of Sub-Channel Bandwidth for mobile OFDM systems," MMT'97, Melbourne, Australia, dec. 1997
- [7] M. Batarriere, K. Braum, T. P. Krauss "Cyclic Prefix Length Analysis for 4 G OFDM Systems," VTC'04, Los Angeles, USA, sept. 2004
- [8] K. L. Baum, T. A. Kostas, P. J. Sartori, B. K. Classon, "Performance Characteristics of Cellular Systems With Different Link Adaptation Strategies", *IEEE Trans. Vehicular Technology*, Vol. 52, No. 6, November 2003.
- [9] C. Lim, Y. Chang, J. Cho, P. Joo, H. Lee, "Novel OFDM Transmission Scheme to Overcome ISI Caused by Multipath Delay Longer than Cyclic Prefix," VTC'05, Stockholm, Sweeden, May. 2005
- [10] 3GPP TR 25.943, "Deployment aspects," June 2002
- [11] 3GPP R1-050386, "Views on OFDM Parameter Set for Evolved UTRA Downlink", Athens, Greece May, 2005