

**GEOLOGIC AND HYDROLOGIC INVESTIGATIONS,  
REESE AIR FORCE BASE, LUBBOCK, TEXAS**

**Charles W. Kreitler, Rainer K. Senger,  
and Thomas C. Gustavson,  
Principal Investigators**

**Bureau of Economic Geology  
W. L. Fisher, Director  
The University of Texas at Austin  
Austin, Texas 78713**

**for U.S. Army Corps of Engineers  
under Contract No. DACA56-88-M-0153**

**April 1989**

BUREAU OF ECONOMIC GEOLOGY

THE UNIVERSITY OF TEXAS AT AUSTIN

University Station, Box X • Austin, Texas 78713-7508 • (512) 471-1534 or 471-7721 • FAX 471-0140  
10100 Burnet Road • Austin, Texas 78758-4497

April 10, 1989

Mr. Frank W. Parker  
Chief, Engineering and  
Construction Division  
Department of the Army  
Tulsa District, Corps of Engineers  
P.O. Box 61  
Tulsa, Oklahoma 74121-0061

Dear Mr. Parker:

Enclosed are five copies of the revised final report entitled "Geologic and Hydrologic Investigations, Reese Air Force Base, Lubbock, Texas." The seven changes to the final report that you requested have been made. Please let me know if additional changes are needed.

Sincerely,

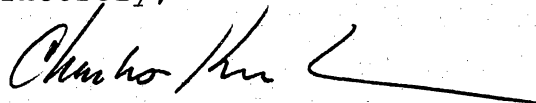

Charles W. Kreitler  
Research Scientist

CWK:lch  
Enclosure

cc: D. Ratcliff  
S. Stubbs  
C. Warren

**GEOLOGIC AND HYDROLOGIC INVESTIGATIONS,  
REESE AIR FORCE BASE, LUBBOCK, TEXAS**

**Charles W. Kreitler, Rainer K. Senger,  
and Thomas C. Gustavson,  
Principal Investigators**

**Bureau of Economic Geology  
W. L. Fisher, Director  
The University of Texas at Austin  
Austin, Texas 78713**

**for U.S. Army Corps of Engineers  
under Contract No. DACA56-88-M-0153**

**April 1989**

## CONTENTS

EXECUTIVE SUMMARY.....	1
INTRODUCTION.....	2
GEOLOGIC STUDIES.....	3
Geologic Setting.....	3
Methodology.....	3
Stratigraphy.....	6
Blackwater Draw Formation.....	6
Ogallala Formation.....	10
Mid-Tertiary Unconformity.....	12
Cretaceous.....	13
HYDROLOGIC STUDIES.....	13
Hydrogeologic Setting.....	13
Methodology.....	14
Observations from Individual Water-Well Hydrographs.....	15
Regional Potentiometric Surface.....	28
Potentiometric Surface of the Base.....	34
Observations from Continuous Water-Level Recordings.....	34
CONCLUSIONS.....	49
PROPOSED FUTURE STUDIES.....	52
ACKNOWLEDGMENTS.....	54
REFERENCES.....	55
APPENDIX I.....	58
FIGURES	
1. Location map and topography of Reese Air Force Base and vicinity.....	4
2. Generalized stratigraphic column for Mesozoic and Cenozoic strata, Reese Air Force Base.....	5

3. Structure-contour map on the base of the Ogallala Formation or the Middle Tertiary erosional surface.....	7
4. Isopach map of the combined thicknesses of the Ogallala and Blackwater Draw Formations.....	8
5. Stratigraphic cross section showing simplified lithologic logs of core from Reese Air Force Base.....	9
6. Location of wells with hydrographs in the six-county area.....	16
7. Water-level hydrograph of well 24-32-304.....	17
8. Water-level hydrograph of well 23-25-401.....	18
9. Water-level hydrograph of well 24-32-501.....	19
10. Water-level hydrograph of well 24-24-901.....	20
11. Water-level hydrograph of well 23-17-801.....	22
12. Water-level hydrograph of well 23-17-802.....	23
13. Water-level hydrograph of well 23-25-304.....	24
14. Water-level hydrograph of well 23-34-903.....	25
15. Water-level hydrograph of well 11-51-503.....	26
16. Water-level hydrograph of well 24-31-601.....	27
17. Water-level hydrograph of well 24-45-902.....	29
18. Regional potentiometric surface, water levels from January 1967.....	30
19. Regional potentiometric surface, water levels from January 1986.....	31
20. Difference in water levels between 1986 and 1967 from Figures 18 and 19.....	32
21. Local potentiometric surface, water levels from August 1986.....	35
22. Local potentiometric surface, water levels from January 1988.....	36
23. Local potentiometric surface, water levels from June 1988.....	37
24. Location of hydrologic monitoring wells on Reese Air Force Base.....	38
25. Continuous water-level records, well WS-1.....	40
26. Continuous water-level records, well WS-5.....	41
27. Continuous water-level records, well WS-12.....	42

28. Continuous water-level records, well 1-1.....	44
29. Continuous water-level records, well 2-1.....	45
30. Continuous water-level records, well 4-1.....	46
31. Variations in barometric pressure and amounts of daily precipitation.....	47

GEOLOGIC AND HYDROLOGIC INVESTIGATIONS,  
REESE AIR FORCE BASE, LUBBOCK, TEXAS

EXECUTIVE SUMMARY

The Bureau of Economic Geology has characterized the geology and hydrology of the Ogallala and Blackwater Draw Formations at Reese Air Force Base to provide baseline information for better delineation of contamination on the base. Examination of five cores identified two predominant depositional facies, eolian sands and fluvial gravels. The gravels appear to be continuous across the base and may represent the major water-bearing unit; therefore, they may be the prime conduit for contaminant migration in the ground water beneath the base. Continuous water-level recorder data from water-supply wells and monitoring wells on the base indicated typically confined and unconfined conditions. The degree of confinement may be controlled by the wells' proximity to the playa lakes on the base or by the relation of the water levels in the wells relative to the top of the water-bearing gravel unit. This variability in the degree of confinement indicates a more complex hydrologic setting than is normally recognized for the Ogallala aquifer.

## INTRODUCTION

In the fall of 1987, ground-water contaminants were discovered in Ogallala aquifer beneath Reese Air Force Base, Lubbock, Texas (fig. 1). In the spring of 1988, the Bureau of Economic Geology at The University of Texas at Austin was asked by the USAF Air Training Command through the U.S. Army Corps of Engineers (Tulsa District) to characterize the geology and hydrology of the Ogallala and Blackwater Draw Formations at Reese Air Force Base to provide baseline information for better delineation of contamination on the base.

Geologic and hydrologic tasks performed were:

### Geologic tasks

1. Review available geologic data in the region.
2. Describe geologic core from four wells at Reese Air Force Base.
3. Obtain short core of shallow Blackwater Draw Formation with Bureau sampler (because coring with a water-well rig is difficult at shallow depths).
4. Review available geologic data from other wells onsite.
5. Construct isopach and structure maps of Ogallala and Blackwater Draw Formations.
6. Develop depositional systems interpretation of Ogallala and Blackwater Draw Formations at Reese Air Force Base and surrounding area.

### Hydrologic tasks

1. Review available literature on hydrogeology of Ogallala aquifer in the greater Lubbock area (20-mile radius around Reese Air Force Base).
2. Construct regional potentiometric surface map on and around Reese Air Force Base. Construct a potentiometric surface map for different time periods to evaluate historical and seasonal changes.
3. Install one or two continuous water-level recorders for 2-3 days per well to determine if wells are screened in confined or unconfined parts of the aquifer.
4. Install a continuous water-level recorder from April through July to measure seasonal ground-water-level variations beneath the base from surrounding irrigation operations.
5. Collect barometric and precipitation data from Reese Base meteorological station to be compared to water-level data.



## GEOLOGIC STUDIES

### Geologic Setting

Reese Air Force Base, which lies on the Southern High Plains, is located approximately 11 miles west of Lubbock, Texas (fig. 1). The Southern High Plains is a flat, low-relief surface that slopes regionally to the east and southeast at about 10 ft per mile. In the vicinity of Reese Air Force Base the High Plains slope from west to east. The High Plains surface is punctuated with numerous shallow circular playa lake basins. All or part of six playa basins are present within the confines of the base. There is no integrated surface drainage on the base, and all drainage is into playa basins.

The base overlies the northern flank of the Paleozoic Midland Basin and lies a few miles south of the east-west-trending crest of the Matador Arch. These Paleozoic features are overlain by fluvial and lacustrine sediments of the Triassic Dockum Group and by Lower Cretaceous marine shales, limestones, and sandstones. Cretaceous sediments are separated from the overlying Miocene-Pliocene eolian and fluvial sediments of the Ogallala Formation by a widespread unconformity. In turn, the Ogallala Formation is overlain by the Quaternary eolian Blackwater Draw Formation. The High Plains surface is developed on the Blackwater Draw Formation. Figure 2 is a generalized stratigraphic column for strata underlying Reese Air Force Base.

### Methodology

Geologic studies at Reese Air Force Base were undertaken to provide the geologic framework for hydrologic analyses. These studies included preparation of maps and a cross section that characterize the stratigraphy of the Ogallala and Blackwater Draw Formations and description and interpretation of core from these formations. Cores were taken by the U.S. Army Corps of Engineers from five sites drilled on Reese Air Force

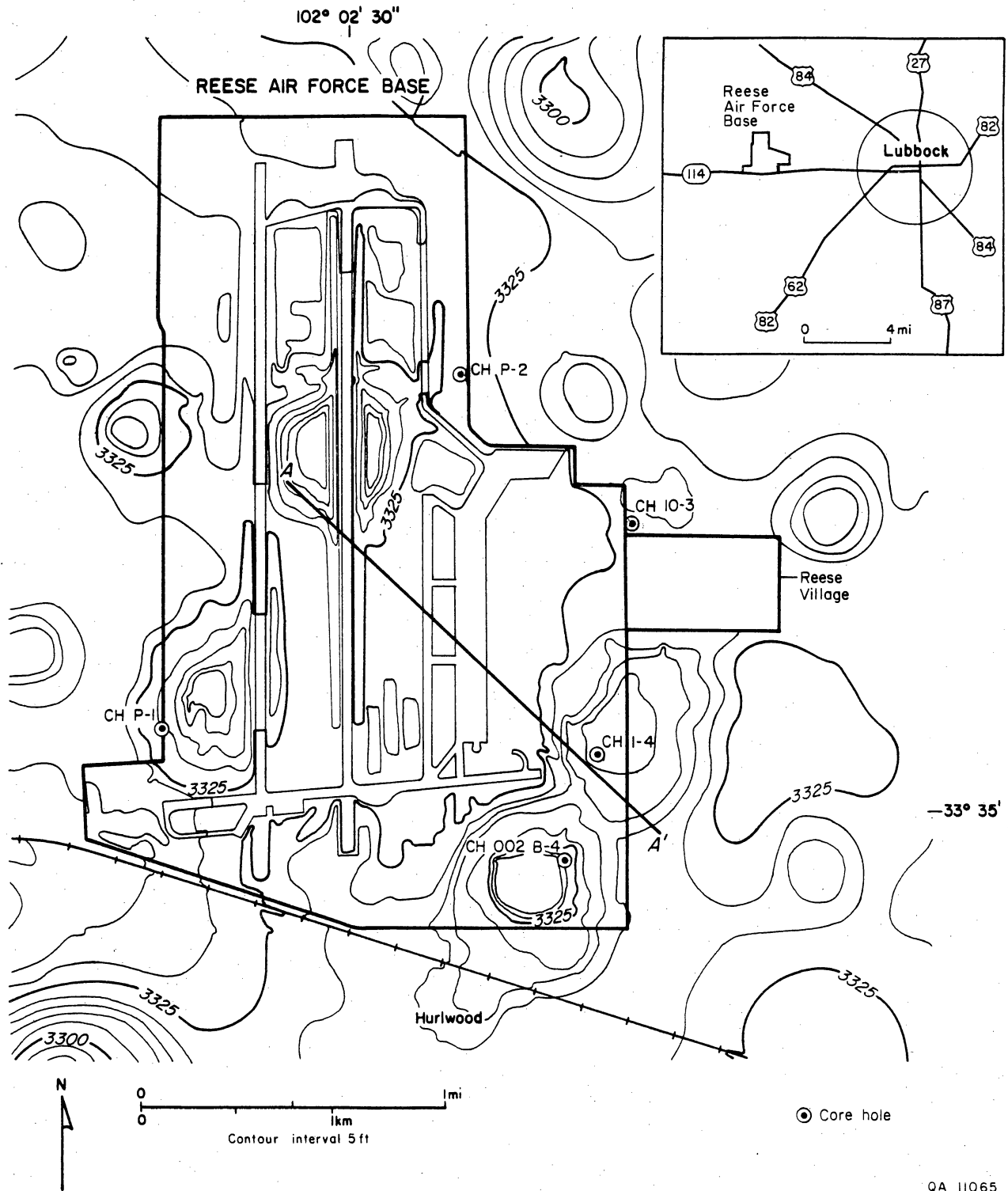

Figure 1. Location map and topography of Reese Air Force Base and vicinity. Core holes P-1, P-2, and 10-3 were drilled as part of this project; core holes 1-4 and 002-B4 (core hole 4 ft away from well 2-2) were drilled in 1987. Topography from Wolfforth Quadrangle, Texas 7.5-minute topographic series. All of the map area is underlain by the Quaternary Blackwater Draw Formation.

<b>Period</b>	<b>Formation/Group</b>
Quaternary	Blackwater Draw Fm.
Miocene-Pliocene	Ogallala Fm.
Cretaceous	Duck Creek Shale
Triassic	Dockum Gp.

Figure 2. Generalized stratigraphic column for Mesozoic and Cenozoic strata, Reese Air Force Base.

Base; three cores were taken as part of the current project, and two cores were taken during 1987 (fig. 1). Core recovery for from holes P-1, P-2, and 10-3 ranged from 68 to 88 percent. At sites for core holes P-1 and P-2, shallow cores from the surface to approximately 20 ft were taken by the Bureau of Economic Geology. These shallow cores were obtained using a Giddings Soil Probe, which is a trailer-mounted hydraulic ram. All cores are stored at the Bureau of Economic Geology Core Research Center at The University of Texas in Austin, Texas. Cores were measured and described in terms of sedimentary, biologic, and pedogenic structures, grain size, cement, and color. Core descriptions for holes P-1, P-2, 10-3, 1-4, and 002-B4 are in the appendix (p. 57-62).

Maps completed as part of this project include a structure-contour map on the base of the Ogallala Formation (fig. 3) and an isopach map of the combined thicknesses of the Ogallala and Blackwater Draw Formations (fig. 4). These maps were derived from a combination of published data available from the Texas Department of Water Resources (driller's logs) and the U.S. Geological Survey (Wolfforth Quadrangle, 7.5-minute series) and from data from test holes drilled as part of this project. Figure 5, a geologic cross section of the study area, was derived from geologic logs of core taken at Reese Air Force Base.

## STRATIGRAPHY

### Blackwater Draw Formation

The Quaternary Blackwater Draw Formation is exposed at the surface of the Southern High Plains and overlies the Miocene-Pliocene Ogallala Formation. Gustavson and Holliday (1988) and Holliday (1988) have interpreted the Blackwater Draw Formation as consisting entirely of eolian sediments deposited as loess and sand sheets. Cores of the Blackwater Draw Formation were taken by the Bureau of Economic

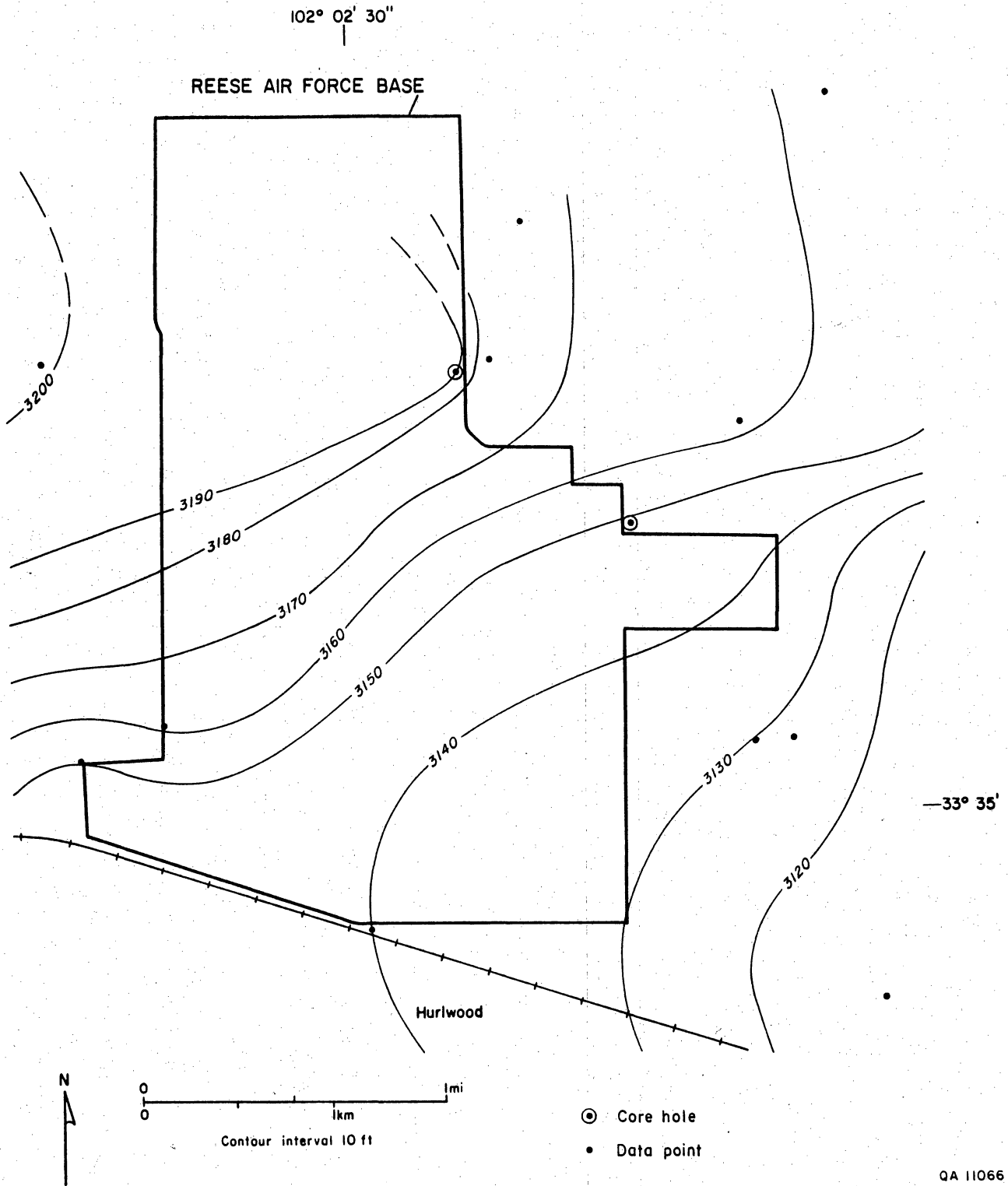

Figure 3. Structure-contour map on the base of the Ogallala Formation or the Middle Tertiary erosional surface. Map interpreted from core hole data and from data from Knowles and others (1984).

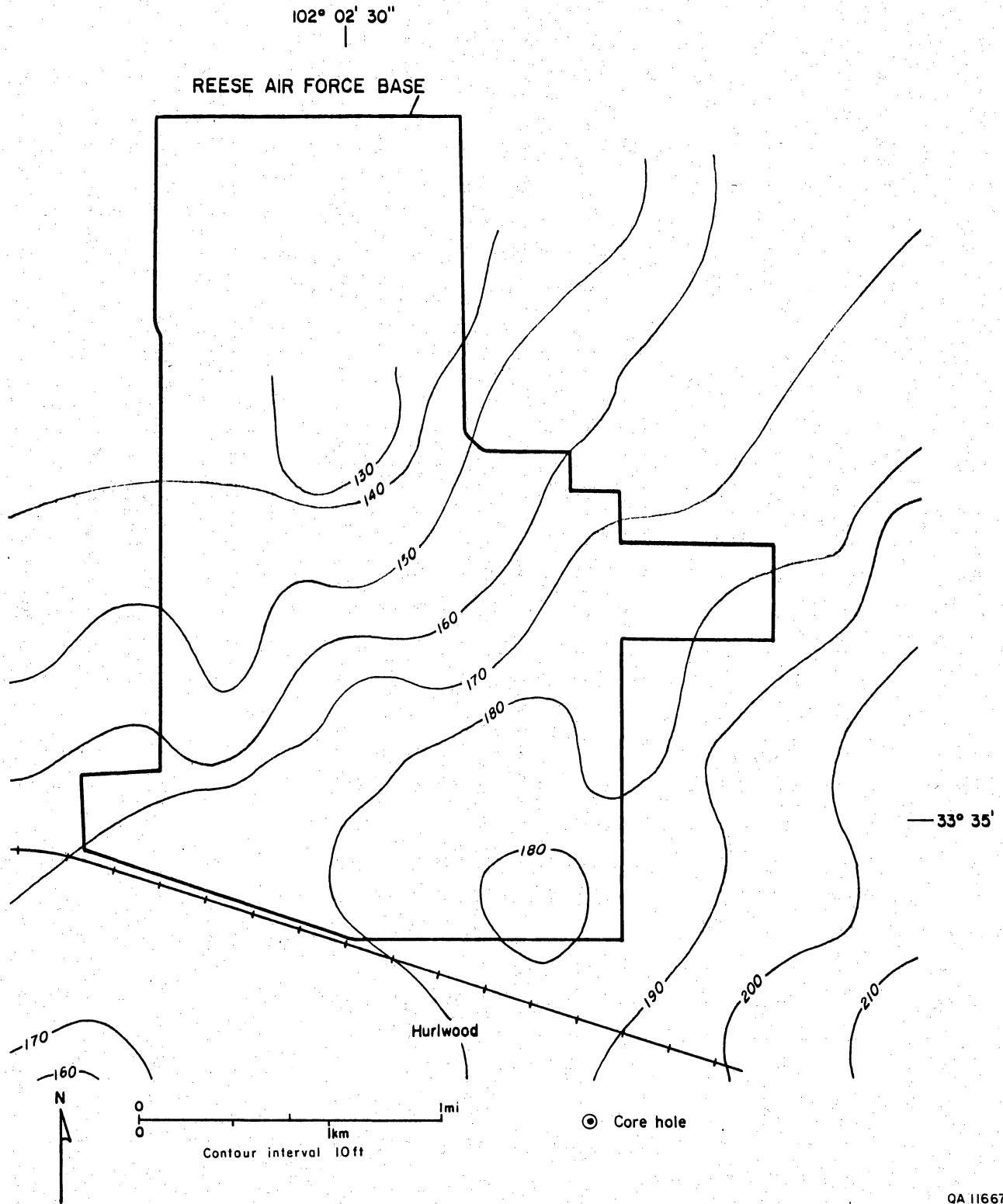

Figure 4. Isopach map of the combined thicknesses of the Ogallala and Blackwater Draw Formations. Map interpreted from computed elevation differences between the Middle Tertiary erosional surface map (fig. 3) and surface topography (fig. 1).

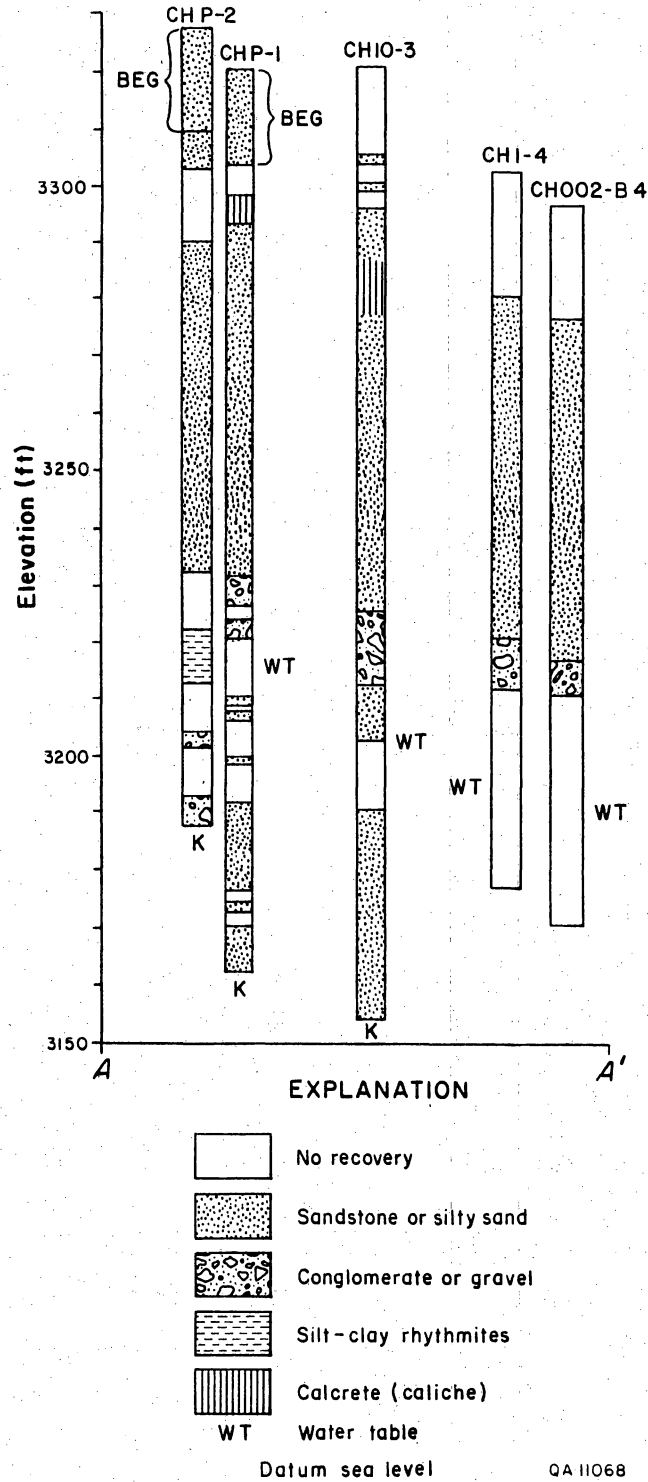

Figure 5. Stratigraphic cross section showing simplified lithologic logs of core from Reese Air Force Base. Line (A-A') is shown in Figure 1. CH-4 is core from well 1-4 and CH-5 is core from well 002-B4. BEG indicates segments of CH-1 and CH-2 cored by the Bureau of Economic Geology.

Geology at the sites of core holes P-1 and P-2 (appendix). At Reese Air Force Base the Blackwater Draw consists of very fine sand to coarse silt. Pedogenic structures include  $\text{CaCO}_3$  filaments, nodules, and calcrete beds. Primary sedimentary structures are not preserved. Cores were taken by hydraulic ram to depths of approximately 20 ft. Penetration of the hydraulic ram below approximately 20 ft was prevented in both holes by a dense calcrete horizon, which probably marks the top of the Ogallala Caprock caliche.

### Ogallala Formation

At Reese Air Force Base the Miocene-Pliocene Ogallala Formation rests unconformably on Cretaceous strata and is overlain by the Quaternary Blackwater Draw Formation. Winkler (1985), Gustavson and Holliday (1988), and Gustavson and Winkler (1988) report that lower Ogallala strata commonly consist of both eolian and fluvial sediments and that upper Ogallala strata are mostly eolian.

According to descriptions of three cores taken by the U.S. Army Corps of Engineers (appendix), the Ogallala Formation is approximately 140 ft thick at Reese Air Force Base. The combined thickness of the Ogallala and Blackwater Draw Formations ranges from less than 130 ft beneath a playa basin in the northern part of the base to more than 180 ft in the southeastern part (fig. 4). Stage IV pedogenic calcretes (Machette, 1985), presumably the Caprock caliche, mark the top of the Ogallala Formation in core holes P-1 and 10-3. The upper 60 to 66 ft of the Ogallala Formation consists of very fine sand to coarse silt. Primary sedimentary structures are not preserved in these sections. Calcium carbonate cement ranges from poor to well-developed. Certain horizons are uncemented. Color, which was determined by comparison with the rock color chart of Goddard and others (1948), ranges from 5YR 7/2 (lighter, grayish-orange-pink) to 5YR 6/4 (darker, light-brown), with lighter colors occurring in well-cemented horizons. Pedogenic  $\text{CaCO}_3$  nodules (5YR 8/1, pinkish-gray) are rare to common.



Siliceous nodules (5YR 5/2-6/1, pale-brown to light-brownish-gray) where silica has replaced both  $\text{CaCO}_3$  cement and  $\text{CaCO}_3$  nodules are rare. Rhizoliths (root tubules) are rare to common. Sediments of the upper part of the Ogallala Formation are similar to Ogallala strata described by Winkler (1985), Gustavson and Holliday (1988), and Gustavson and Winkler (1988) as having been deposited as loess and sand sheets in a semiarid to subhumid grassland savanna.

Cores from holes 1-4 and 002-B4 were taken in 1987 by the U.S. Army Corps of Engineers from beneath playa lake basins on Reese Air Force Base. Upper Ogallala sediments in these core differ from Ogallala sediments in cores P-1, P-2, and P-3 only in that they are lighter colored (5YR 8/1 to 5YR 7/2, pinkish-gray to grayish-orange-pink).

The first occurrence of fluvial sediments in the five cores ranged from depths of 82 to 110 ft or from elevations of 3,222 to 3,232 ft (fig. 5). Gravels in wells P-1, 10-3, 1-4, and 002-B4 are at similar elevations and may well form a sheet-like deposit that dips to the southeast at a few feet per mile. Gravel in well P-2, however, occurs 10 to 20 ft below the previously mentioned gravels and may not be connected to them. The total thickness of fluvial sediments in each of the five wells is unknown because of poor recovery in holes P-1, P-2, and 10-3 and because wells 1-4 and 002-B4 were completed within the fluvial sediments. Gravel clasts are composed of quartzites, metasediments, and vein quartz and are locally cemented to form conglomerates. The long axes of clasts range up to 3 inches. In hole 10-3, 15 ft of gravel is preserved.

In hole 3, gravels are underlain by at least 9 ft of fluvial cross-laminated fine sand and laminated silty clay, and clay. Sediments are moderate brown (5YR 4/4) and uncemented to poorly cemented with  $\text{CaCO}_3$ . The section from 120 to 130 ft is not recovered in hole 10-3. In hole P-2 the section beneath the gravel consists of 10 ft of laminated silt and silty clay rhythmites (textually graded sequence of sediments) that

were probably deposited in a pond or lake. In hole P-1 fluvial gravels lie directly on eolian sediments composed of very fine sand to coarse silt.

Strata between the fluvial section and the base of the Ogallala in holes P-1, P-2, and 10-3 are mostly poorly cemented to uncemented very fine sand to coarse silt. These moderate yellowish-brown (10YR 5/4) sediments contain rare to common pedogenic carbonate nodules but do not preserve primary sedimentary structures. Sediments in this section of the Ogallala are similar to upper Ogallala strata and are also interpreted as loess and sand sheet deposits.

Porosity of Ogallala sediments varies with the degree of  $\text{CaCO}_3$  cement development. Ogallala sandstones and siltstones contain up to an estimated 20 percent porosity (Arten Avakian, written communication, 1988). Intergranular porosity is commonly partly occluded by carbonate cement or illuviated clay cutans on framework grains. Intergranular porosity may be completely occluded in strongly developed calcretes, such as the Caprock Caliche, where framework grains are floating in micrite cement. Porosity is also present as fractures and root tubules, which may have been locally enlarged by dissolution. Root tubules commonly are less than 0.5 in wide, but dissolution-enlarged cavities may be as much as several inches wide.

#### Mid-Tertiary Unconformity

The unconformity that separates the Late Tertiary Ogallala Formation from underlying Mesozoic and Paleozoic rocks is present beneath all of the Ogallala Formation. Beneath Reese Air Force Base the unconformity separates the Ogallala Formation from the Lower Cretaceous Duck Creek (?) Shale. Paleovalleys recognized on the pre-Ogallala erosional surface contained streams that flowed east and southeast (Gustavson and Winkler, 1988). The erosional surface slopes to the southeast beneath the base at an average slope of approximately 25 ft/mile (fig. 3). Elevation of the

erosional surface ranges from approximately 3,200 ft beneath the northwest corner of the base to 3,130 ft beneath the southeast corner.

### Cretaceous

Cores from holes 1, 2, and 3 terminate in light-olive-gray to olive-gray clayey shales of the Lower Cretaceous Duck Creek (?) Shale. Thin limestones and crossbedded sandstones are interbedded with the shale. Gryphea sp., an Early Cretaceous mollusk, was recognized in core hole 1 at a depth of 161 ft. No evidence of soil development was recognized at the erosional surface that marks the upper boundary of Cretaceous strata in any of the cores. However, shales and limestones near the top of the Cretaceous strata appeared weathered.

## HYDROLOGIC STUDIES

### Hydrogeologic Setting

The Ogallala aquifer, which underlies the Reese Air Force Base, is an important ground-water source for the Southern High Plains. The Southern High Plains has a semiarid to subhumid climate, with annual mean precipitation ranging from 13 inches in the southwest to 22 inches in the northeast part of the Southern High Plains. Annual mean precipitation in the vicinity of Reese Air Force Base is approximately 17.58 inches. Annual pan evaporation in the area ranges from about 60 to 96 inches (Bomar, 1983; Nelson and others, 1983). The water-bearing units of the aquifer are terrigenous sands and gravel of the Tertiary Ogallala Formation. In most parts, the aquifer is heavily pumped, exceeding annual recharge. As a result, there has been a substantial decrease in ground-water levels in heavily pumped areas. In other locations, however, where the

water table is near land surface, water levels have risen, owing to percolation of surplus water from irrigation or recharge of surface water from playas or from streams that were dammed (Kier and others, 1984).

Various recharge mechanisms have been proposed for the Ogallala aquifer, including diffuse infiltrations, and focused recharge through riverbeds and playas. Knowles and others (1984) suggested higher recharge rates for the sand hills areas of the Southern High Plains because of higher permeability of coarse-grained soils. However, caliche that formed in the upper surface of the Ogallala Formation is regarded as a recharge barrier because it has very low permeability (Ries, 1981; Knowles and others, 1984). Although some caliche was encountered under most playas, the calcified layers are partly dissolved or included sand and were relatively permeable (Lotspeich and others, 1971). Stone (1984) and Wood and Osterkamp (1984) observed significantly lower dissolved solutes in soil samples below playas compared with those in other areas, suggesting focused recharge below playa lakes rather than regional, slow, diffuse percolation.

### Methodology

Hydrologic investigation of the Ogallala aquifer in this study is aimed at characterizing general flow both on a more regional scale and on a site-specific scale. In addition, hydrologic characteristics of the aquifer were studied to infer potential recharge mechanisms in the vicinity of the base. The different hydrologic tasks included (1) reviewing available hydrologic data on the Ogallala aquifer in the greater Lubbock area; (2) constructing the regional potentiometric surface in the vicinity of Reese Air Force Base and locally on the base; and (3) investigating continuous water-level variations and possible responses to rainfall and barometric pressure variations. Water-level data for the greater area around Reese Air Force Base were obtained from the Texas Natural Resources Information System (TNRIS). The maps were prepared using

the contouring package CPS-1 (Radian Corporation) on the Bureau of Economic Geology's VAX computer. Precipitation and barometric pressure data are from the Reese Air Force Base meteorological station.

#### Observations from Individual Water-Well Hydrographs

General hydrologic conditions during the last few decades are evaluated based on individual hydrographs from wells near and on Reese Air Force Base, which include wells from the six-county area surrounding the base, and wells near the base (fig. 6). Water levels in the immediate vicinity of the base indicate a generally uniform pattern throughout the last 30 years. Essentially all hydrographs show a significant decline in water levels until the mid 1960's. From 1966 to 1980, water levels remained approximately constant. Many wells show a slight increase in water levels beginning in the early 1980's.

In well 24-32-304, located just east of Reese Air Force Base, depth to water increased from about 120 ft in 1956 to 140 ft in 1966 ( $\Delta h=20$  ft), and has remained at this approximate level to the present (fig. 7). Water levels in well 23-25-401, which is located east of the base farther toward Lubbock, indicated a more pronounced decline; depth to water increased from about 86 ft in 1950 to 140 ft in 1966 ( $\Delta h=54$  ft); afterward water levels remained relatively uniform, with only a slight increase starting in the early 1980's (fig. 8).

Water levels from well 24-32-501 (fig. 9), located west of the base, show a similar pattern, with depth to water increasing from 90 ft in 1950 to 125 ft in 1966 ( $\Delta h=35$  ft). To the north of the base, depth to water in well 24-24-901 steeply increased from about 86 ft in 1950 to 160 ft in 1966 ( $\Delta h=64$  ft); thereafter, water levels declined slightly by about 10 ft until 1982 (fig. 10).

Northeast of the base, water levels in well 23-17-801 indicate a steep decline in the first half of the 1950's; depth to water increased from about 44 ft in 1951 to 76 ft in

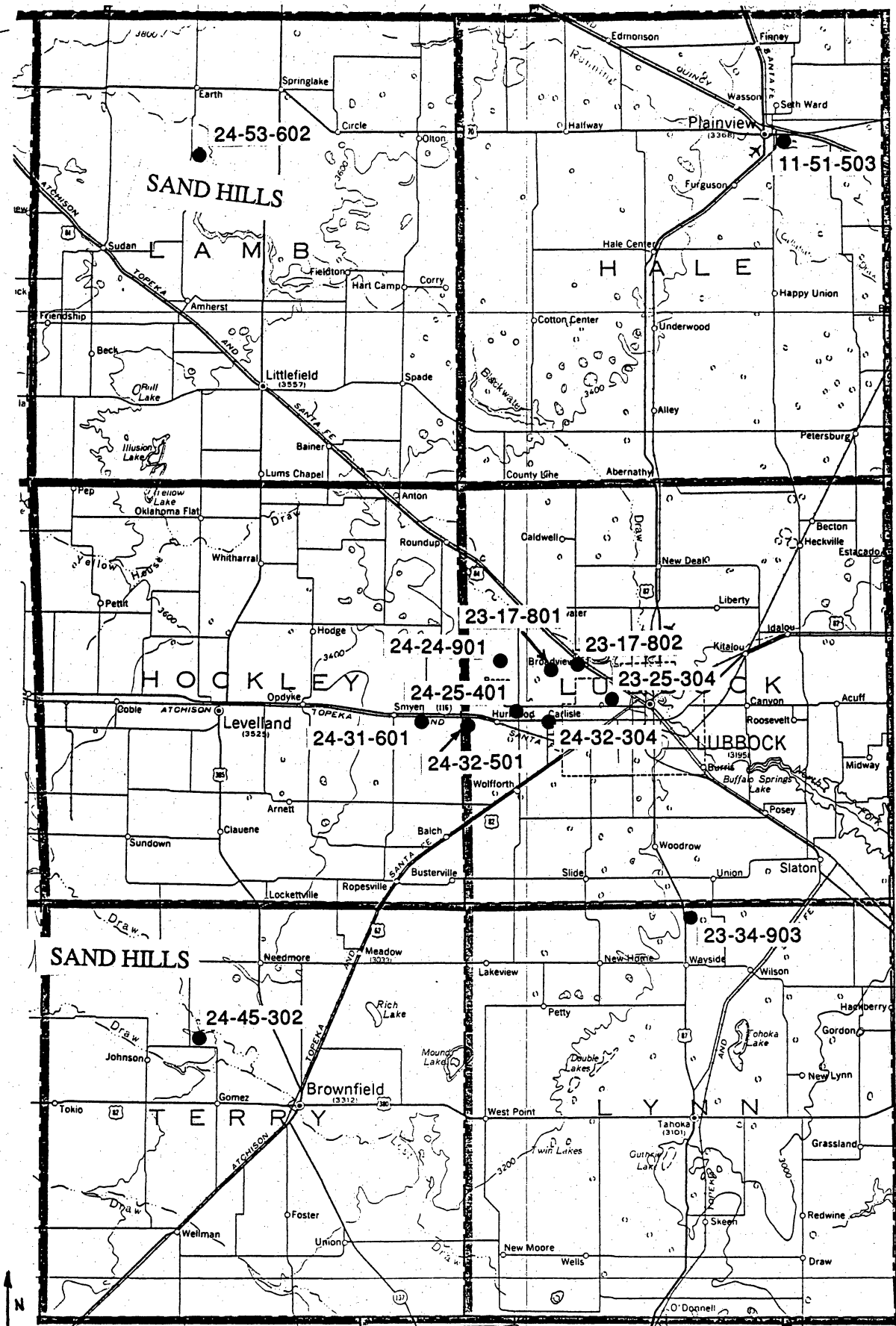

Figure 6. Location of wells with hydrographs in the six-county area.

# HYDROGRAPH 24-32-304

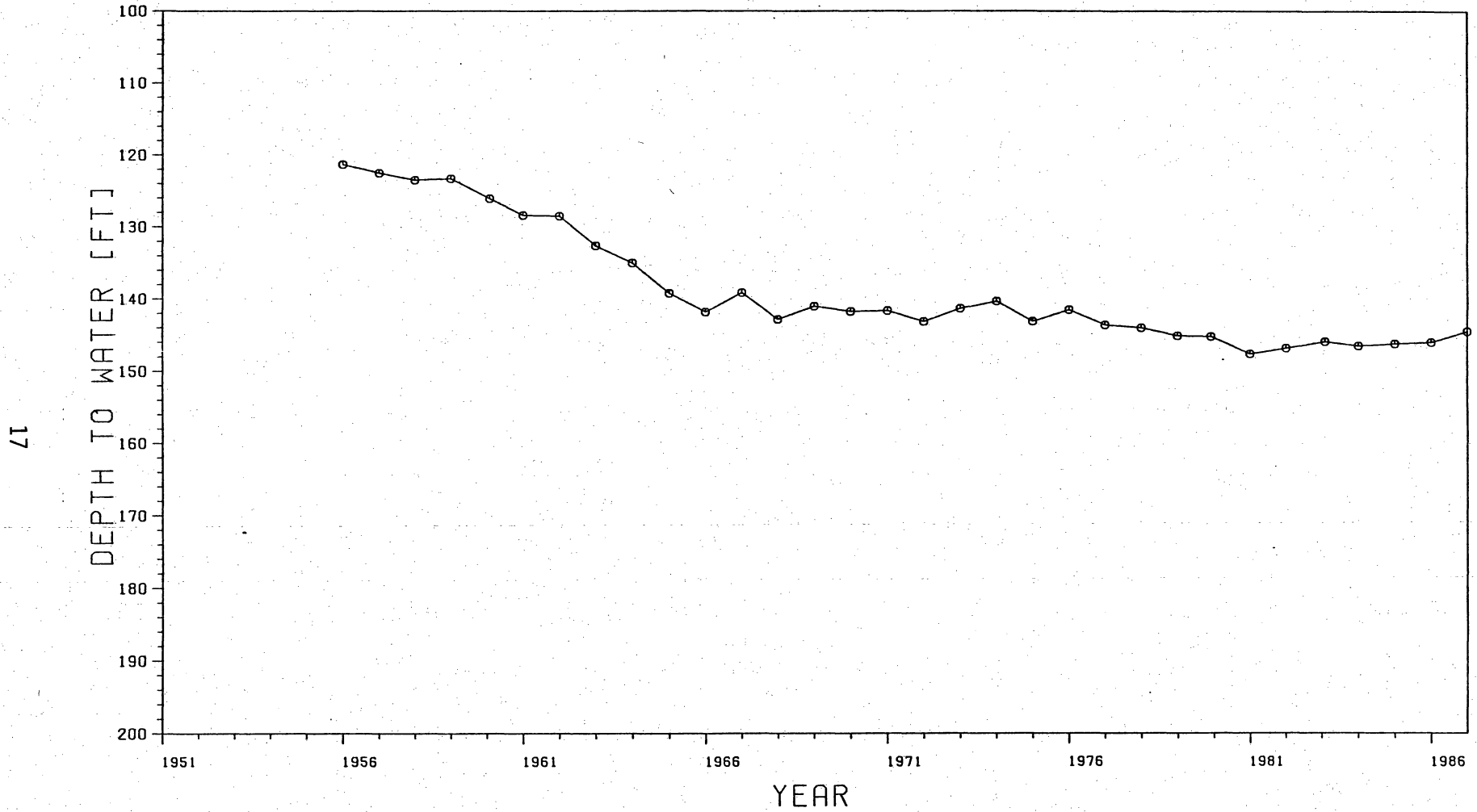

Figure 7. Water-level hydrograph of well 24-32-304. Water-level data from Texas Natural Resources Information System. Location of well shown in Figure 6.

# HYDROGRAPH 23-25-401

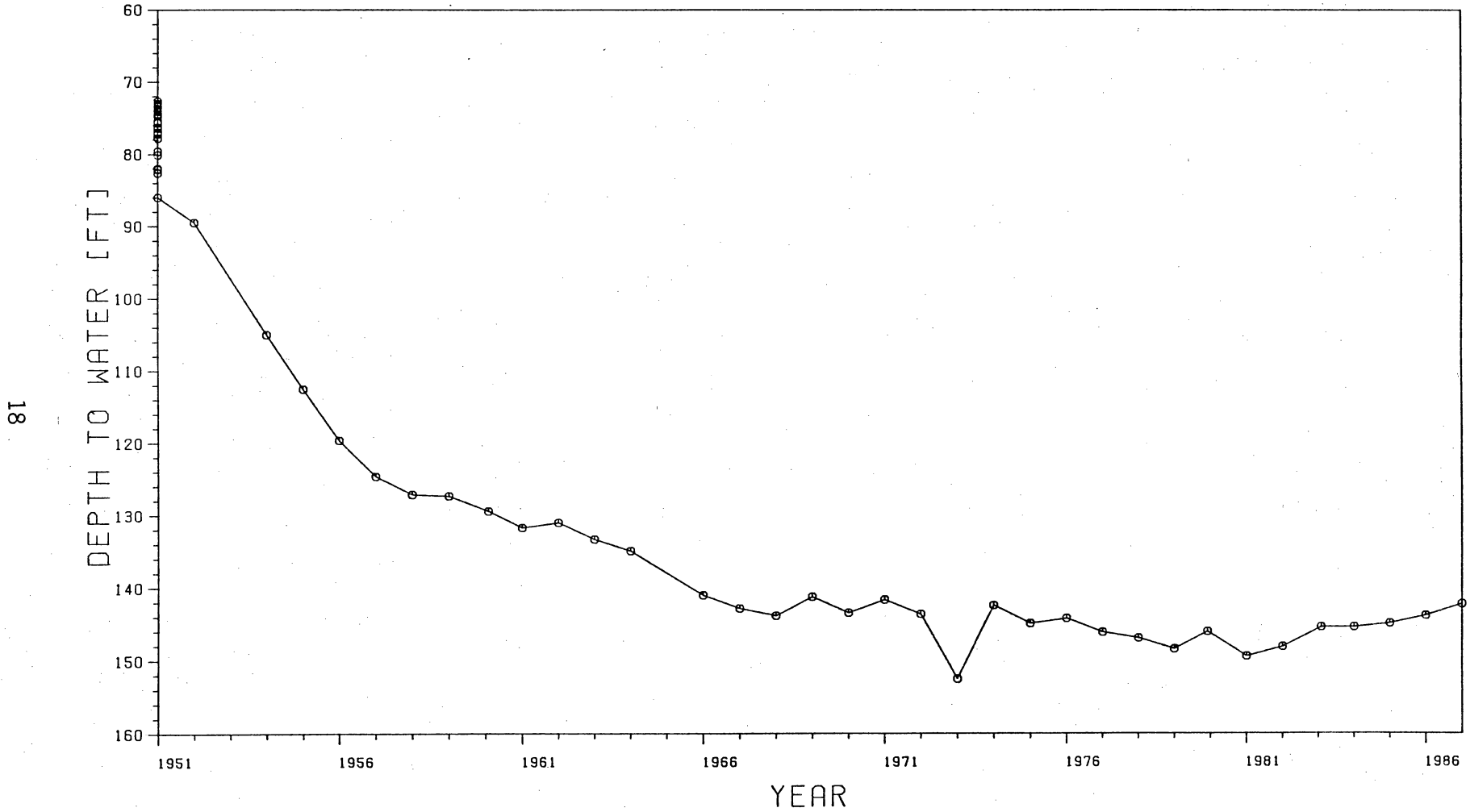

Figure 8. Water-level hydrograph of well 23-25-401. Water-level data from Texas Natural Resources Information System. Location of well shown in Figure 6.



# HYDROGRAPH 24-32-501

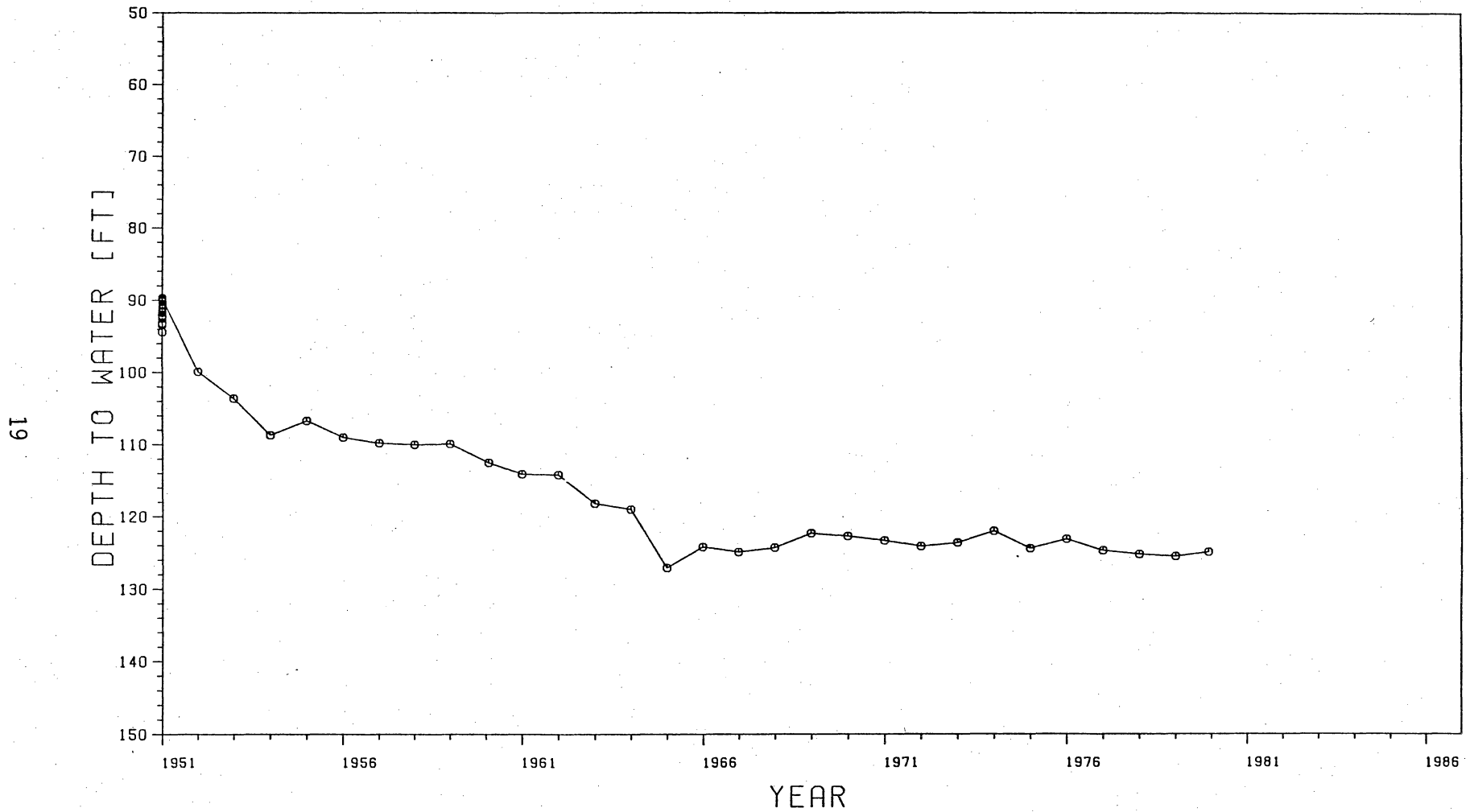

Figure 9. Water-level hydrograph of well 24-32-501. Water-level data from Texas Natural Resources Information System. Location of well shown in Figure 6.

# HYDROGRAPH 24-24-901

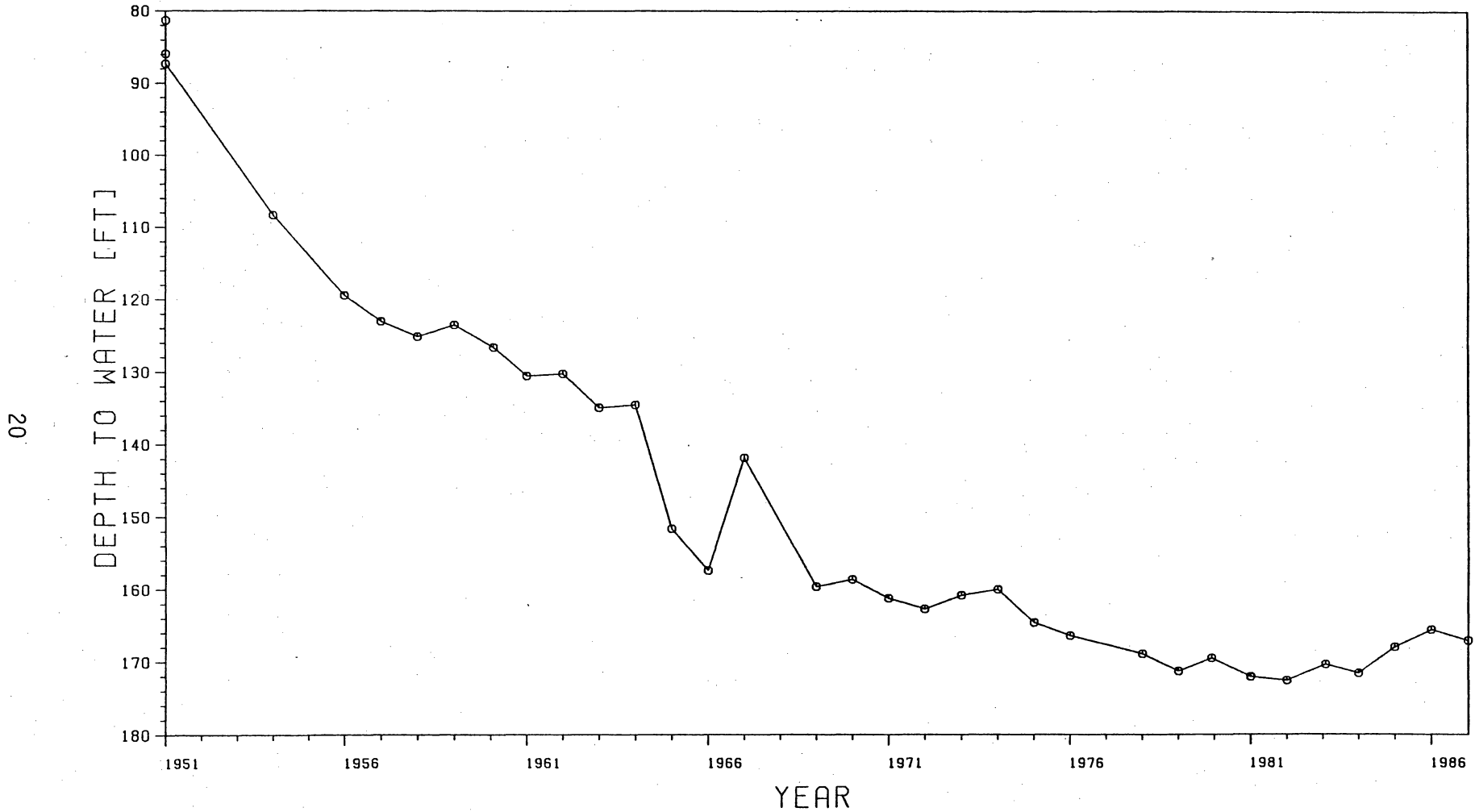

Figure 10. Water-level hydrograph of well 24-24-901. Water-level data from Texas Natural Resources Information System. Location of well shown in Figure 6.

1957. Later the water-level decline slowed and stayed relatively constant from 1966 to 1982, after which water levels slightly increased (fig. 11). In comparison, water-levels in nearby well 23-17-802, located near Yellow House Creek, show a more continuous water-level decline throughout (fig. 12).

Water levels based on monthly measurements from well 23-25-304, located in the city of Lubbock, indicate a completely different pattern; depth to water remained relatively constant from about 1957 to 1967 at about 65 ft below land surface (fig. 13). Beginning in 1967, water levels started to rise; depth to water decreased from about 65 ft to about 40 ft ( $\Delta h=25$  ft). Starting in 1976, water-level rise slowed and, as indicated by the hydrograph, small ( $<5$  ft), distinct, seasonal fluctuations occurred.

The general pattern observed in water levels in the vicinity of Reese Air Force Base (early declines during the 1950's and 60's and the constant water levels thereafter) can be observed in well 23-34-903, located in Lynn County, just south of Lubbock County (fig. 14). In comparison, water levels in well 11-51-503, located in Hale County, north of Lubbock County, show a continuous water-level decline for the entire recorded period. Depth to water increased from about 42 ft in 1950 to 130 ft in 1983 (fig. 15). Water levels in well 10-53-602 in Lamb County, west of Hale County, show a similar pattern. Depth to water continuously increased from about 28 ft in 1950 to 82 ft in 1986 (fig. 16).

Water levels in well 24-31-601, located in Hockley County, west of Lubbock County, indicate a pattern similar to the ones observed in the vicinity of Reese Air Force Base, with depth to water increasing from about 98 ft in 1950 to 120 ft in 1966, after which water levels remained relatively flat (fig. 16). Beginning in 1981, water levels started to rise slightly. To the south, water levels in well 24-45-902, located in Terry County, south of Hockley County, are relatively uniform. Starting in 1968, depth to water started

# HYDROGRAPH 23-17-801

22

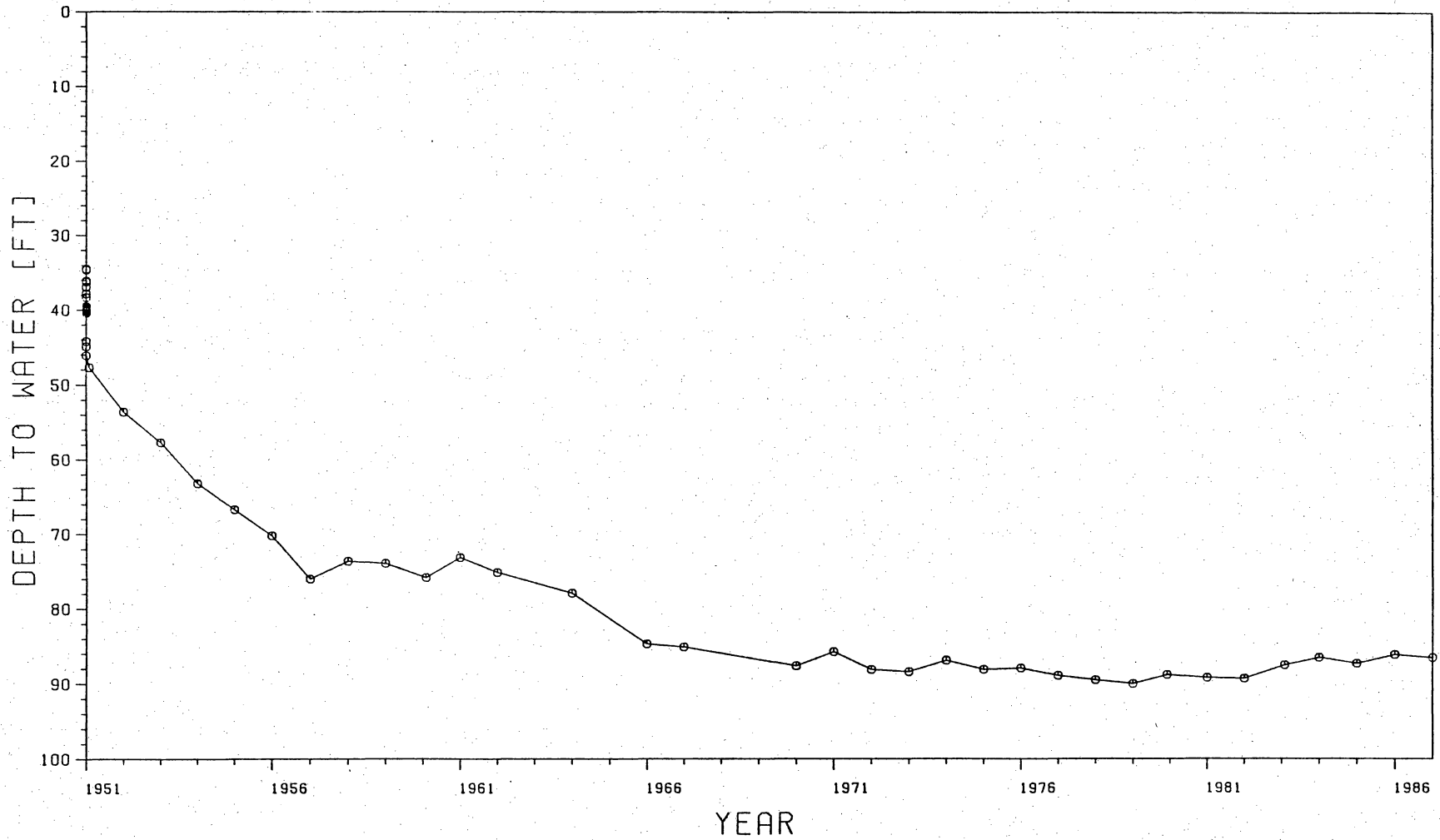

Figure 11. Water-level hydrograph of well 23-17-801. Water-level data from Texas Natural Resources Information System. Location of well shown in Figure 6.

# HYDROGRAPH 23-17-802

23

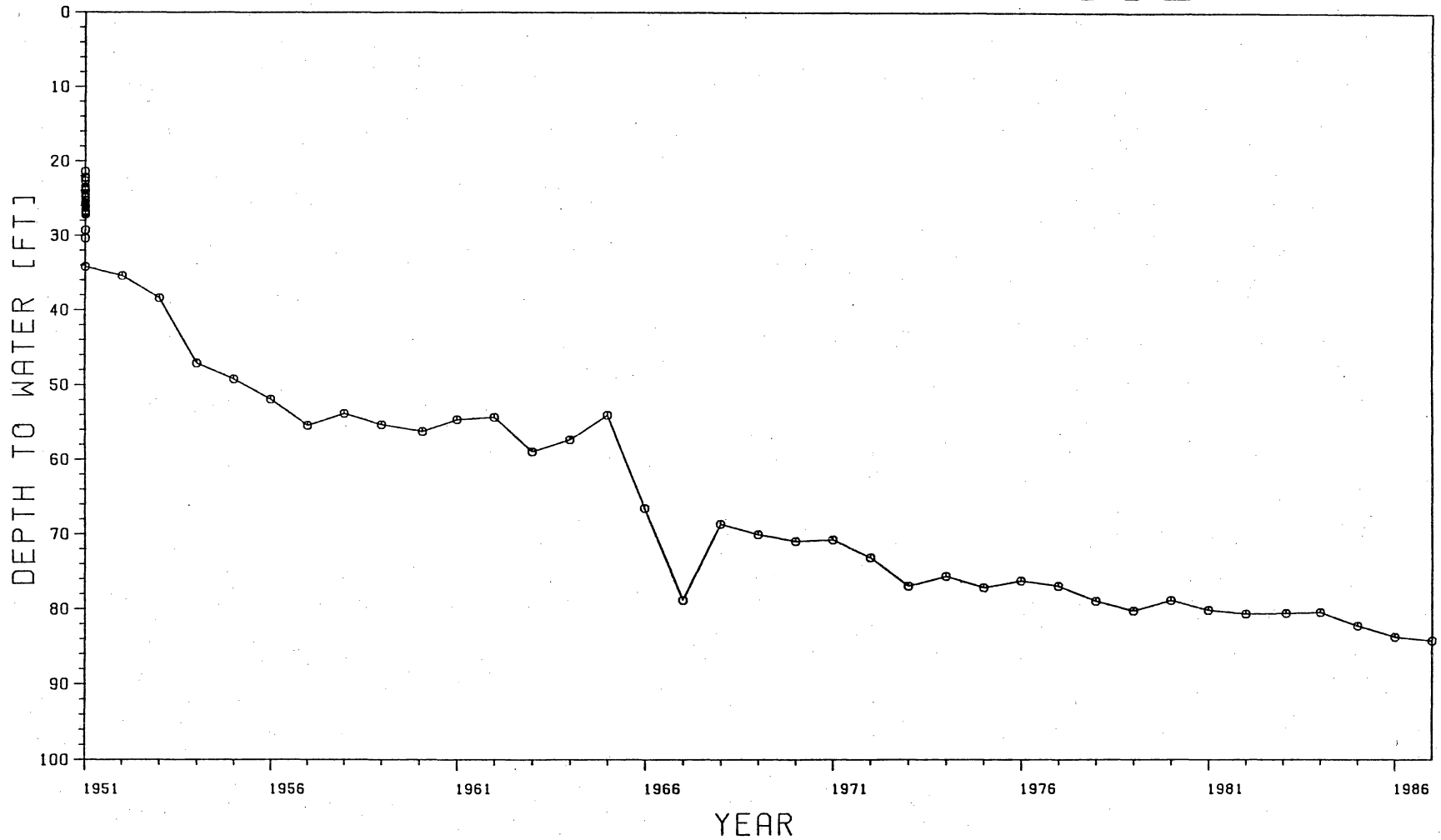

Figure 12. Water-level hydrograph of well 23-17-802. Water-level data from Texas Natural Resources Information System. Location of well shown in Figure 6.

# HYDROGRAPH 23-25-304

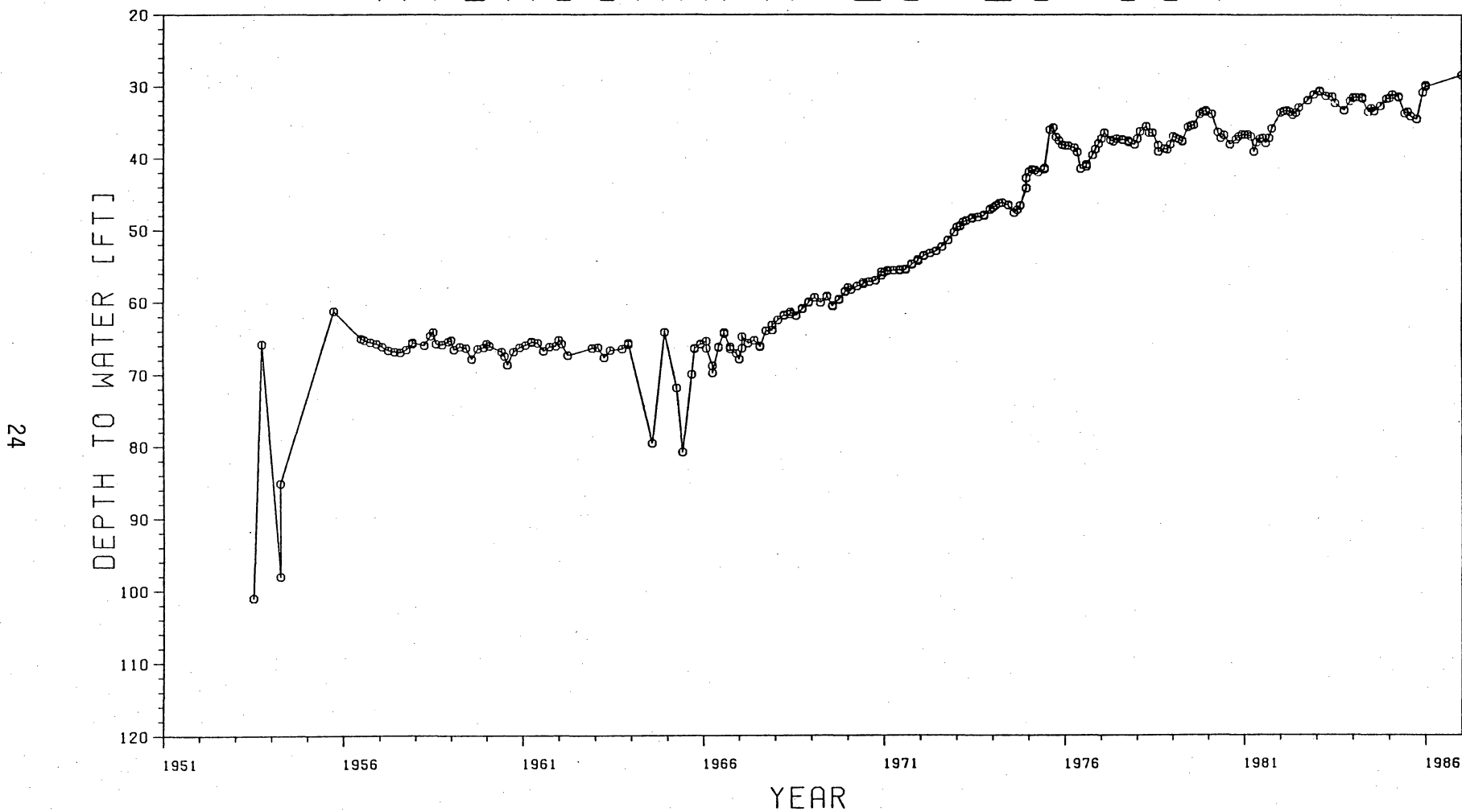

Figure 13. Water-level hydrograph of well 23-25-304. Water-level data from Texas Natural Resources Information System. Location of well shown in Figure 6.

# HYDROGRAPH 23-34-903

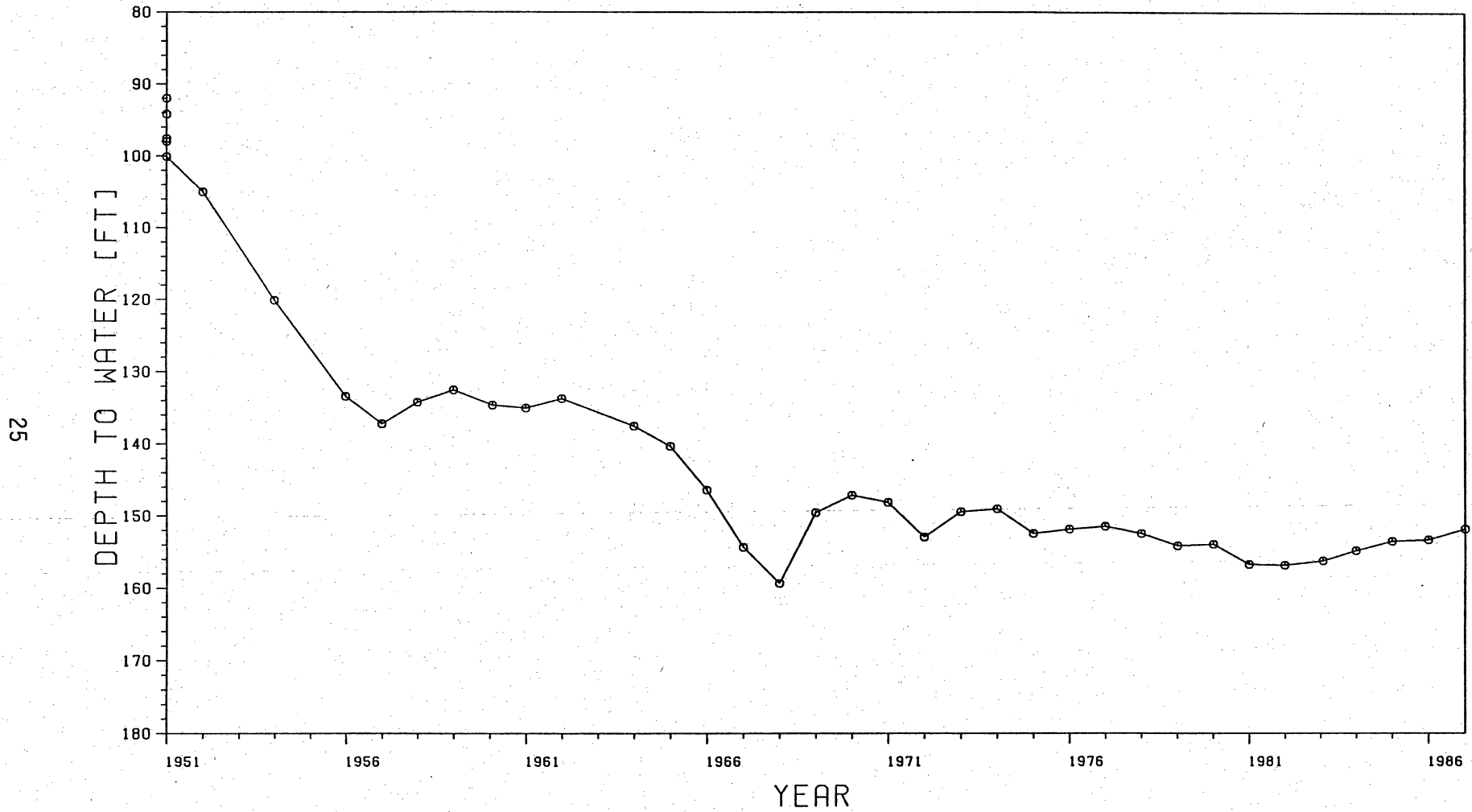

Figure 14. Water-level hydrograph of well 23-34-903. Water-level data from Texas Natural Resources Information System. Location of well shown in Figure 6.

# HYDROGRAPH 11-51-503

26

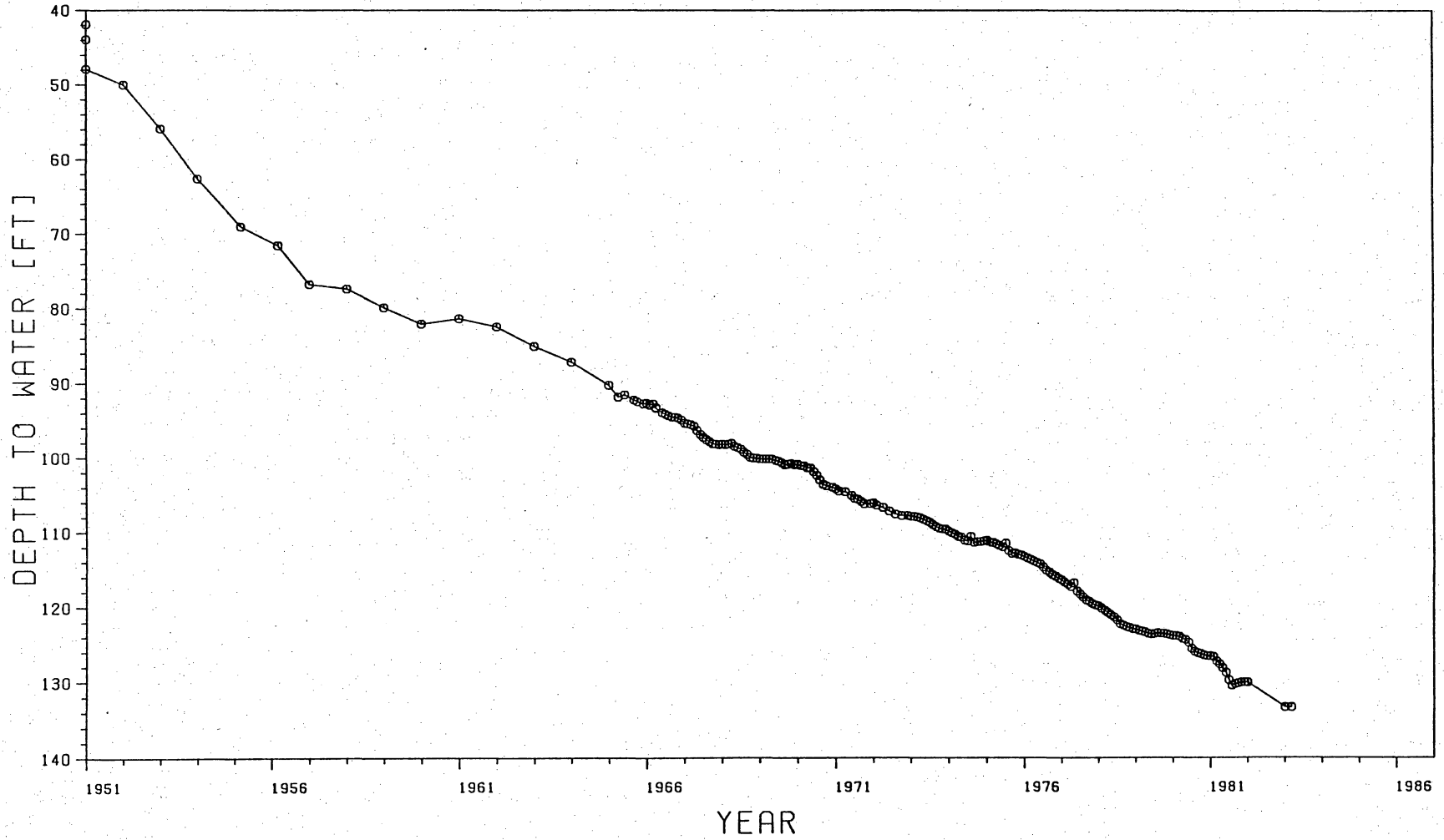

Figure 15. Water-level hydrograph of well 11-51-503. Water-level data from Texas Natural Resources Information System. Location of well shown in Figure 6.



# HYDROGRAPH 24-31-601

27

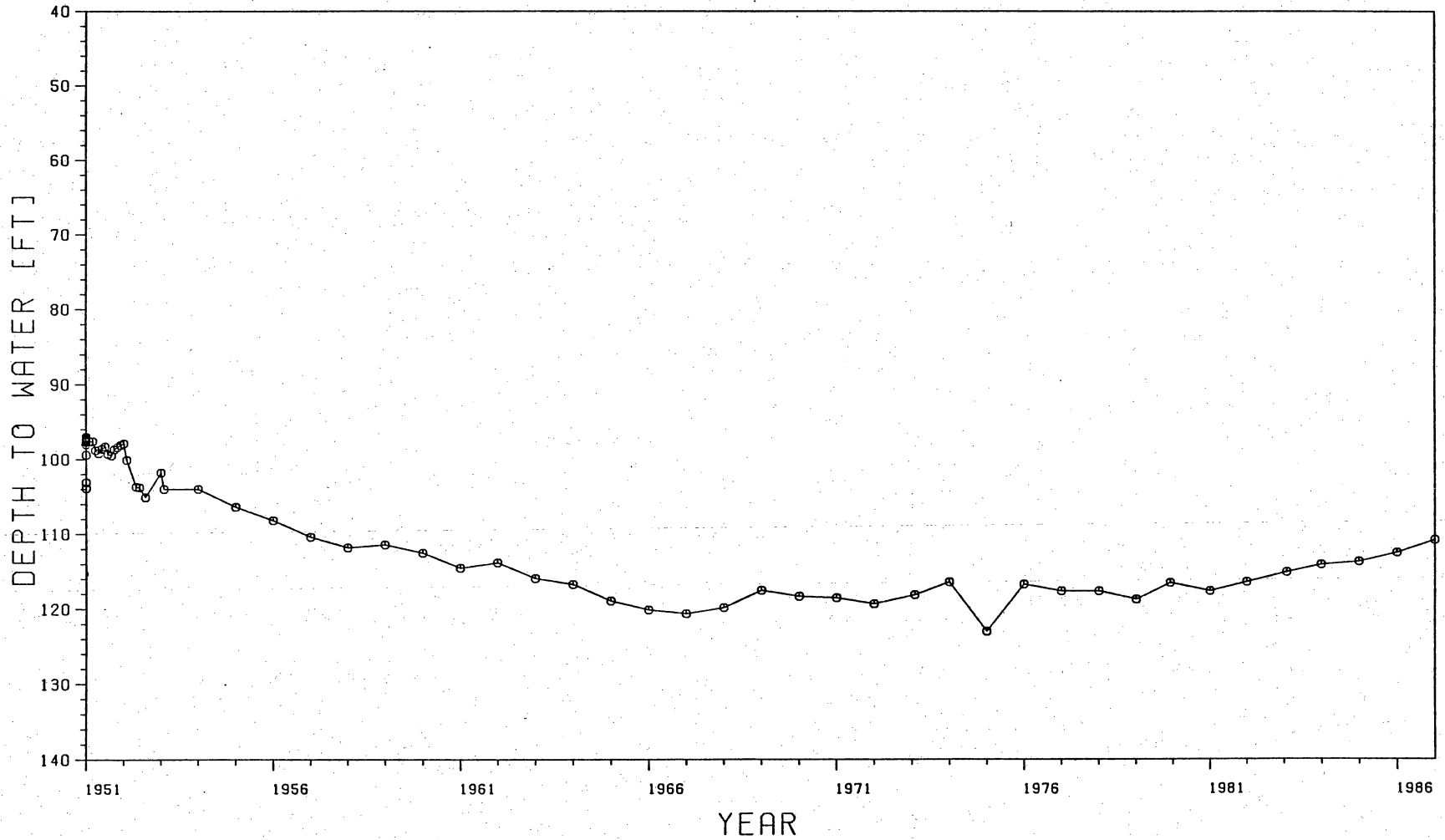

Figure 16. Water-level hydrograph of well 24-31-601. Water-level data from Texas Natural Resources Information System. Location of well shown in Figure 6.

to decrease slightly from about 124 ft to 114 ft in 1984 (fig. 17). Terry and Lynn Counties generally show little overall water-level declines between 1967 and 1986, as shown on the regional potentiometric surfaces (fig. 20).

### Regional Potentiometric Surface

The regional potentiometric maps incorporate water-level data from a six-county area, including Lubbock and Hockley Counties in the central part, Hale and Lamb Counties to the north, and Terry and Lynn Counties to the south. On the basis of the general pattern observed from the individual water-level hydrographs, two maps were constructed: (1) potentiometric surface based on data from 1967, and (2) potentiometric surface based on data from 1986. In addition, a head-difference map was constructed, indicating the change in water levels between 1967 and 1986.

Overall, both potentiometric surface maps show a similar pattern, with a general northwest-to-southeast flow direction following the general topography. Across Reese Air Force Base, flow is mainly from west to east. Hydraulic-head contours for 1986 indicate a ground-water high in the northern half of the base (indicated by convex contours in figs. 18 and 19). Depth to water in the immediate vicinity of the base generally increased from about 5 to 15 ft (fig. 20) between 1967 and 1986.

Several distinct features on the potentiometric surface maps should be pointed out. Beneath the city of Lubbock, an extensive ground-water mound is indicated by closed contours, which developed since 1967 (figs. 18 and 19). This water-level increase of as much as 40 ft is also shown on the head-difference map. The localized recharge in Lubbock is attributed to modifications along Yellow House Draw, where several dams created surface water lakes. Also, several playa lakes in the city were deepened to be used for storm-water runoff. By deepening the playas, the uppermost caliche layer was scraped off, allowing for focused recharge to the Ogallala aquifer.

# HYDROGRAPH 24-45-902

29

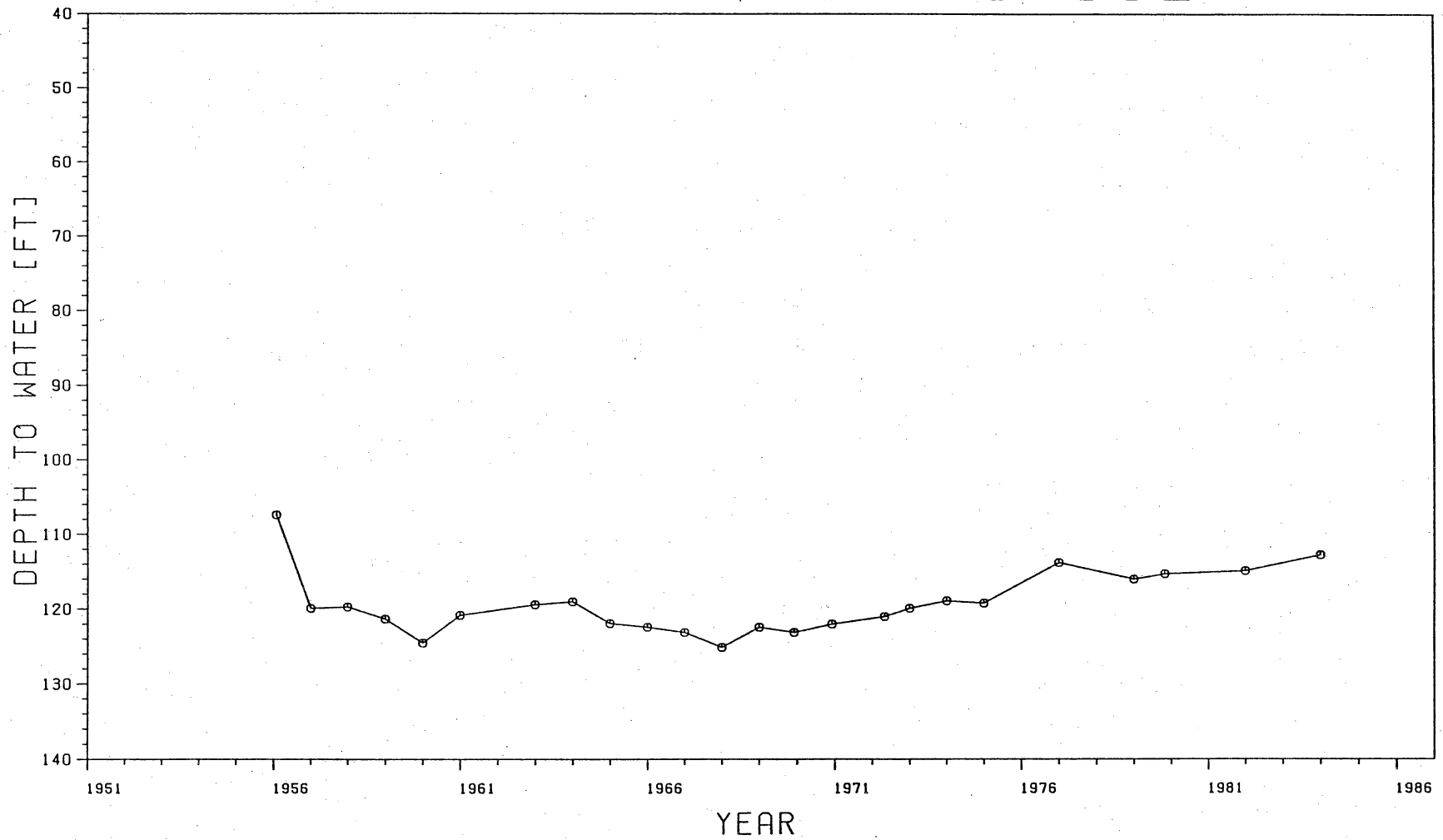

Figure 17. Water-level hydrograph of well 24-45-902. Water-level data from Texas Natural Resources Information System. Location of well shown in Figure 6.

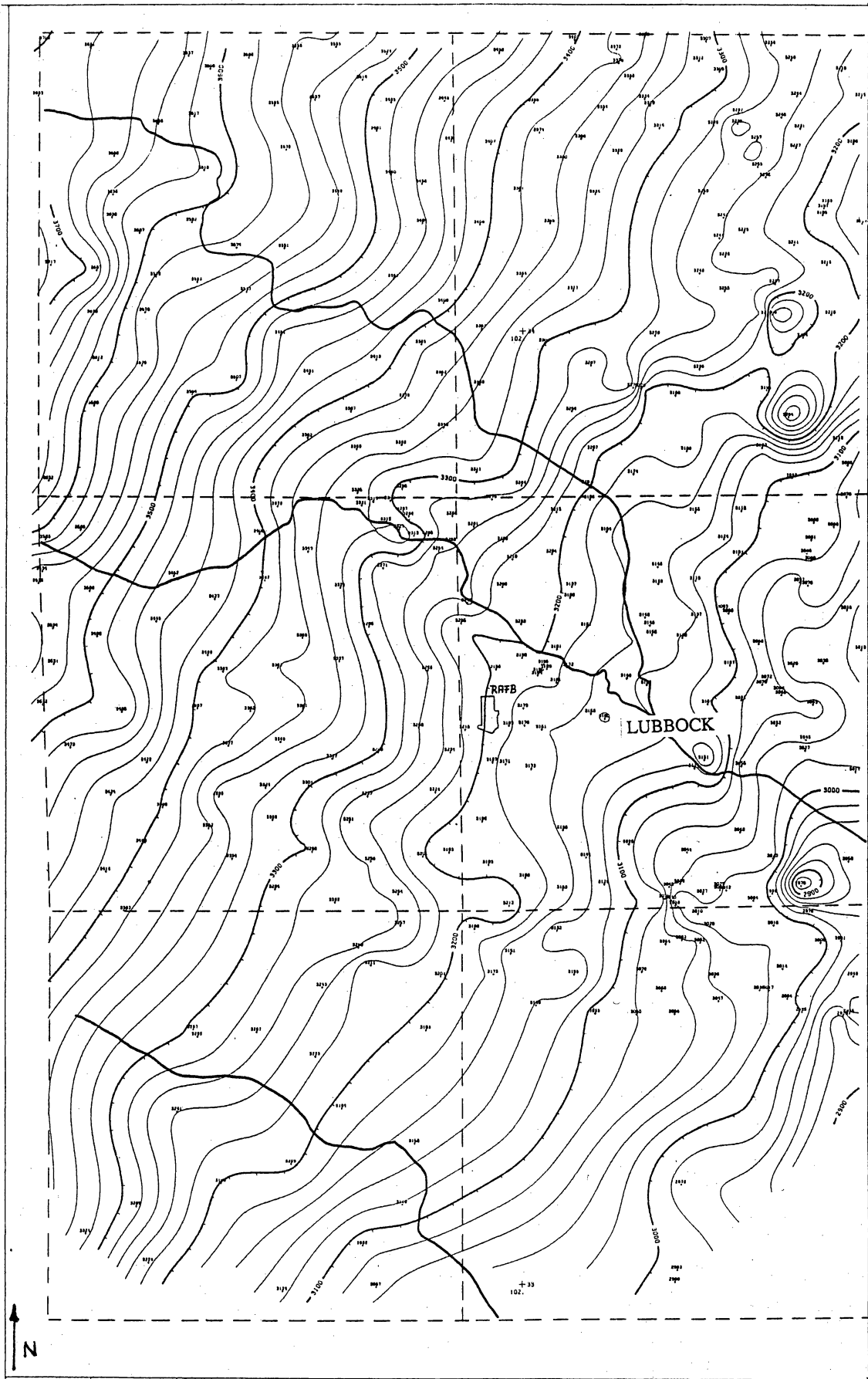

Figure 18. Regional potentiometric surface, water levels from January 1967. Water-level data from Texas Natural Resources Information System.

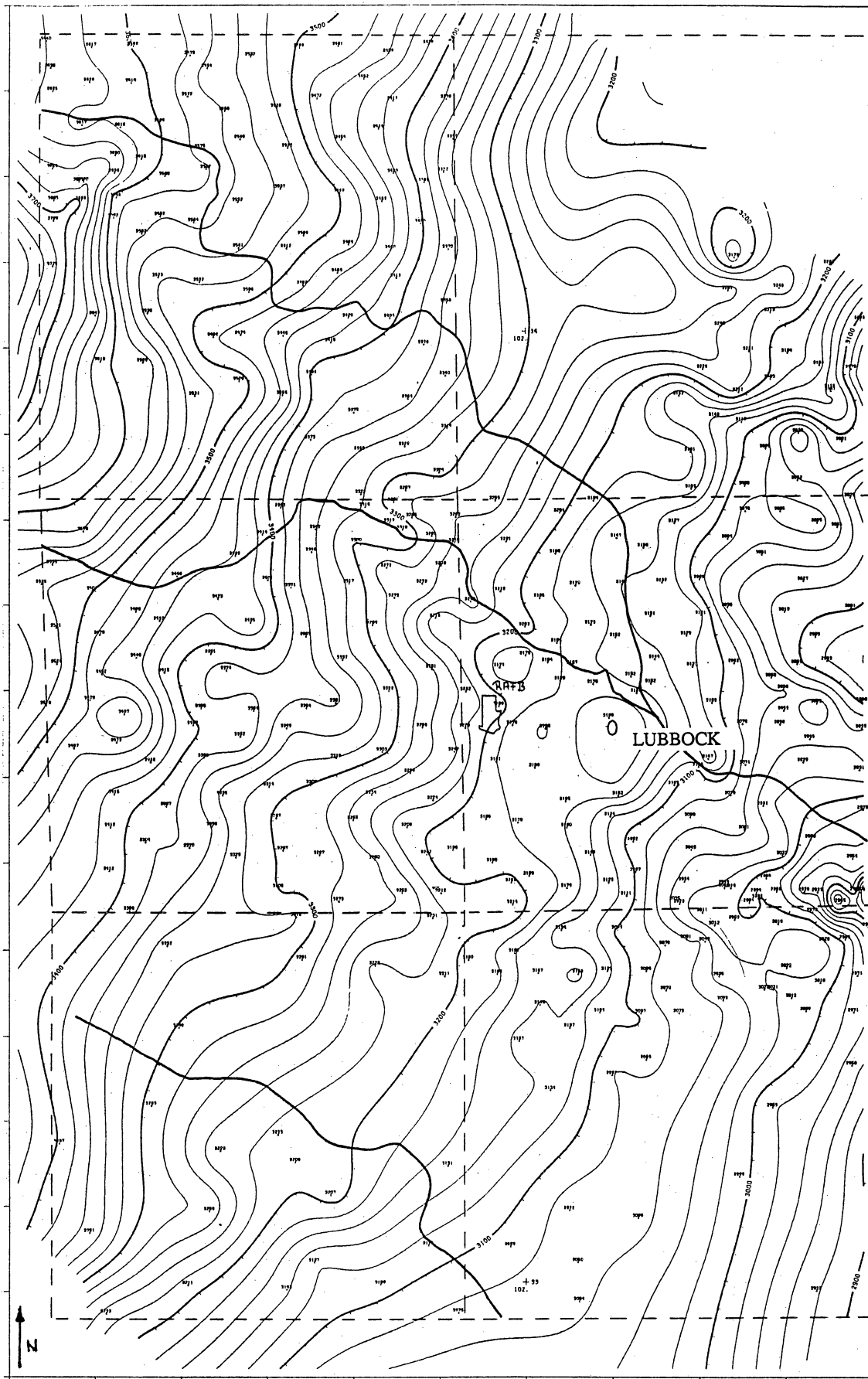

Figure 19. Regional potentiometric surface, water levels from January 1986. Water-level data from Texas Natural Resources Information System.

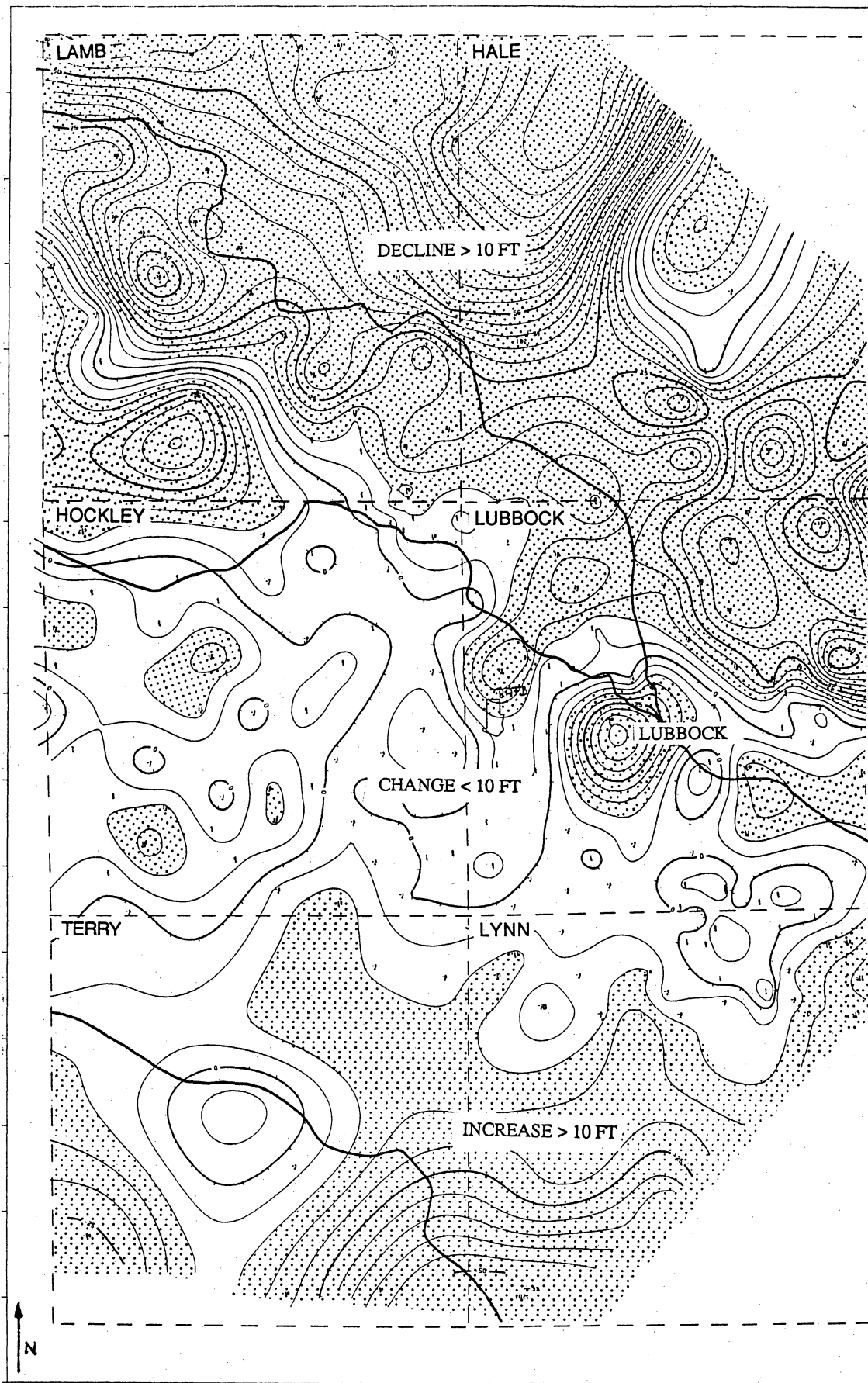

Figure 20. Difference in water levels between 1986 and 1967 from Figures 18 and 19.

North of the Air Force Base along Yellow House Draw, water-level contours are bent convex downstream, indicating ground-water mounding beneath the creek (figs. 18 and 19). This pattern occurs just west of the town of Anton in eastern Hockley County and can be followed to just east of the town of Shallowater in Lubbock County. Ground-water mounding beneath the creek indicates potential recharge of creek water to the Ogallala aquifer. Most dominantly, ground-water mounding occurs just south of Anton. Topographically, this area is characterized by a large depression (larger playa); along the flanks of this playa, the uppermost caprock caliche crops out. The absence of the uppermost caliche layer may therefore enhance potential recharge to the Ogallala aquifer in this area.

Further to the north in Lamb County, another set of convex contours can be observed, which coincides with an area of sand hills characterized by an elongated topographic high with sand dunes and scarce vegetation. Potentiometric surfaces show ground-water mounding beneath the sand hills area (figs. 18 and 19), suggesting potential recharge to the Ogallala. However, because the sand hills are not used for farming, the associated drawdown in the adjacent areas may result in an artificial high just beneath the sand hills. North of the sand hills, the head-difference map showed water-level declines between 1967 and 1986 of generally more than 50 ft (fig. 20). South of the sand hills, water-level declines are generally smaller at about 25 ft, with one exception where water-levels declined as much as 50 ft (fig. 20). Head differences generally decrease southward; south and southwest of Yellow House Draw, water-level declines are generally less than 5 ft, which is related to somewhat reduced withdrawal rates because of higher total dissolved solids of Ogallala ground water in this area.

South and southwest of Reese Air Force Base in Terry and Lynn Counties, the water-level contours show another west-east elongated area with convex contours indicating ground-water mounding. This area lies downdip from sand hills that extend from western Terry County westward (figs. 18 and 19), and may be the result of preferential recharge further updip.

## Potentiometric Surface of the Base

Three potentiometric surfaces of the base area and immediate vicinity were constructed using limited water-level data, supplied by the Corps of Engineers, from water-supply wells and monitoring wells on the base. The three measurement periods are August 1986 (fig. 21), January 1988 (fig. 22), and June 1988 (fig. 23). All three maps show convex contours in the downstream direction with relatively little variations between the different measurement periods. They compare reasonably well with the water-level contours from the 1986 regional map (fig. 19). Hydraulic gradients are generally from west to east in the central part of the base and are more to the southwest and south in the southern part of the base.

## Observations from Continuous Water-Level Recordings

For detailed water-level measurements on Reese Air Force Base, six continuous water-level recorders (Stevens Type F recorders) were installed in water-supply wells WS-1, WS-5, and WS-12 and monitoring wells 1-1, 2-1, and 4-1 (fig. 24). Wells 1-1 and 2-1 are located next to the two water-filled playa lakes, Industrial Lake and Sewage Lake, respectively (fig. 24). Well 4-1 is in the southwestern corner of the base near an abandoned landfill on the base. The three water-supply wells are located in the central part of the base near the runways and maintenance buildings.

Water levels were continuously monitored from June 16, 1988, until July 26, 1988, except for well WS-12, which was monitored for 1 week starting July 21. In addition, a pressure transducer was used for a 24-hour period to record fluid-pressure changes associated with water-level fluctuations in well WS-1. The pressure transducer was used to test whether such small-scale fluctuations (generally less than 1 inch) can be identified. Water-level variations are compared with rainfall and barometric pressure variations recorded by the weather service on the base.



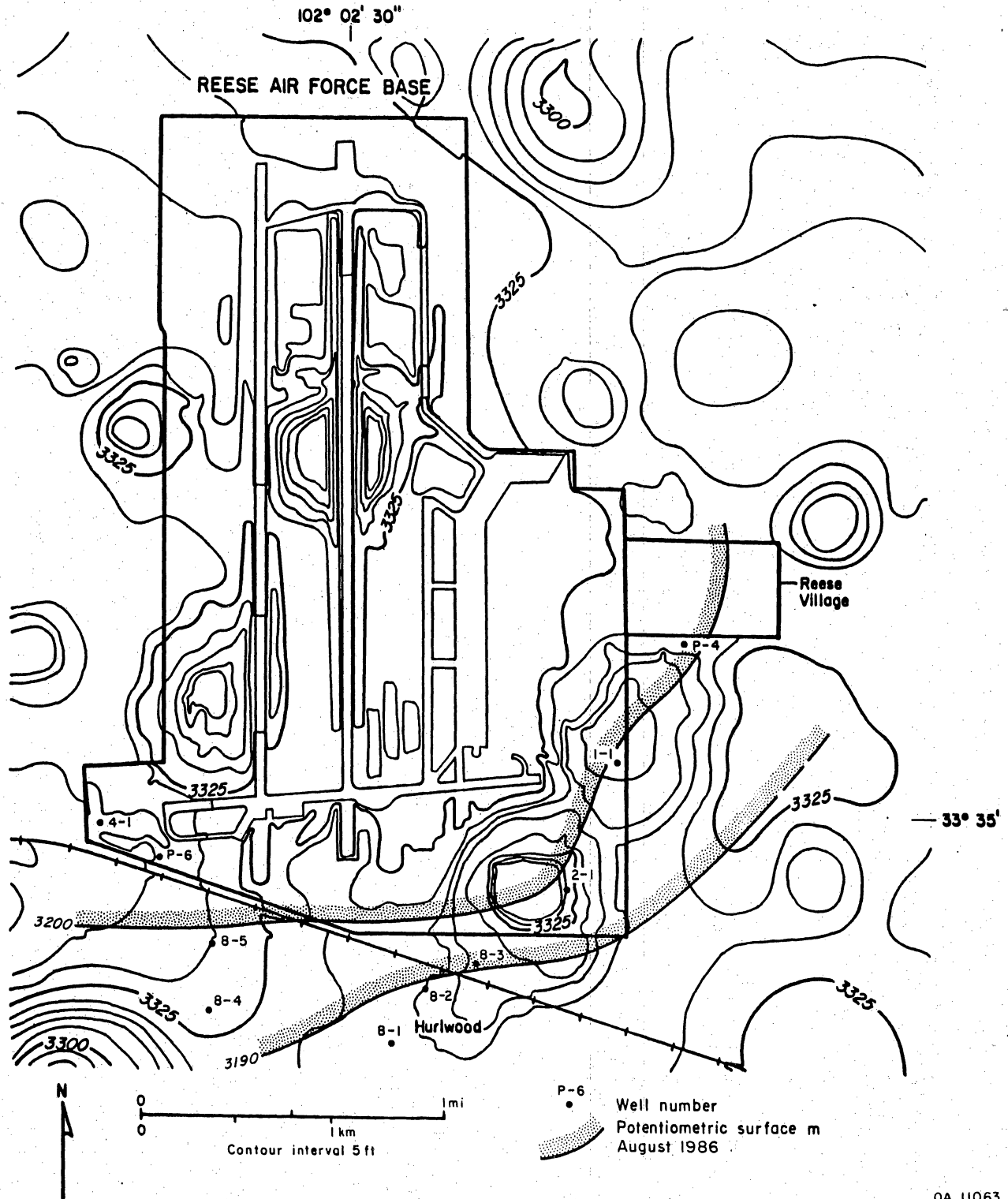

Figure 21. Local potentiometric surface, water levels from August 1986.



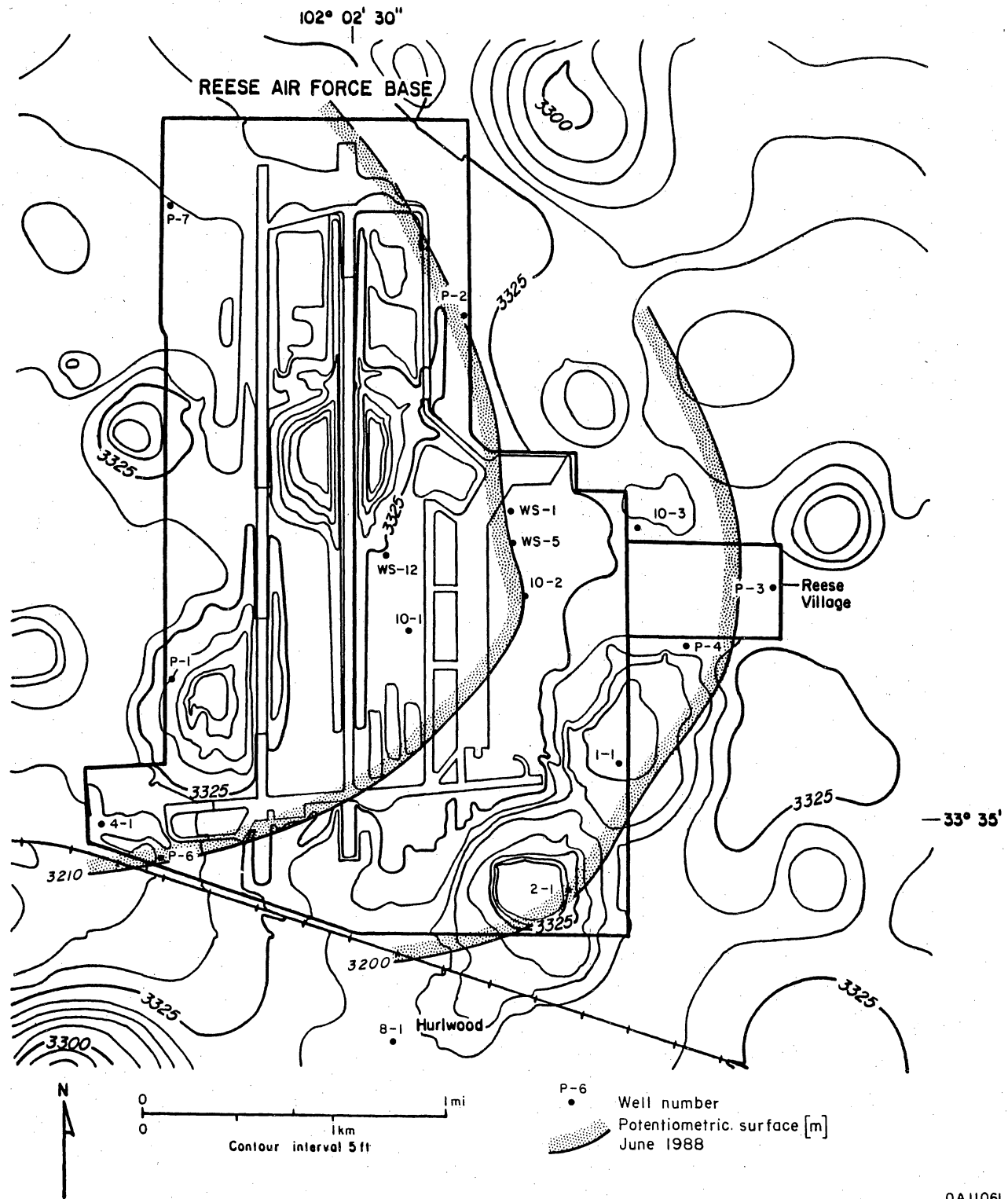

Figure 23. Local potentiometric surface, water levels from June 1988.

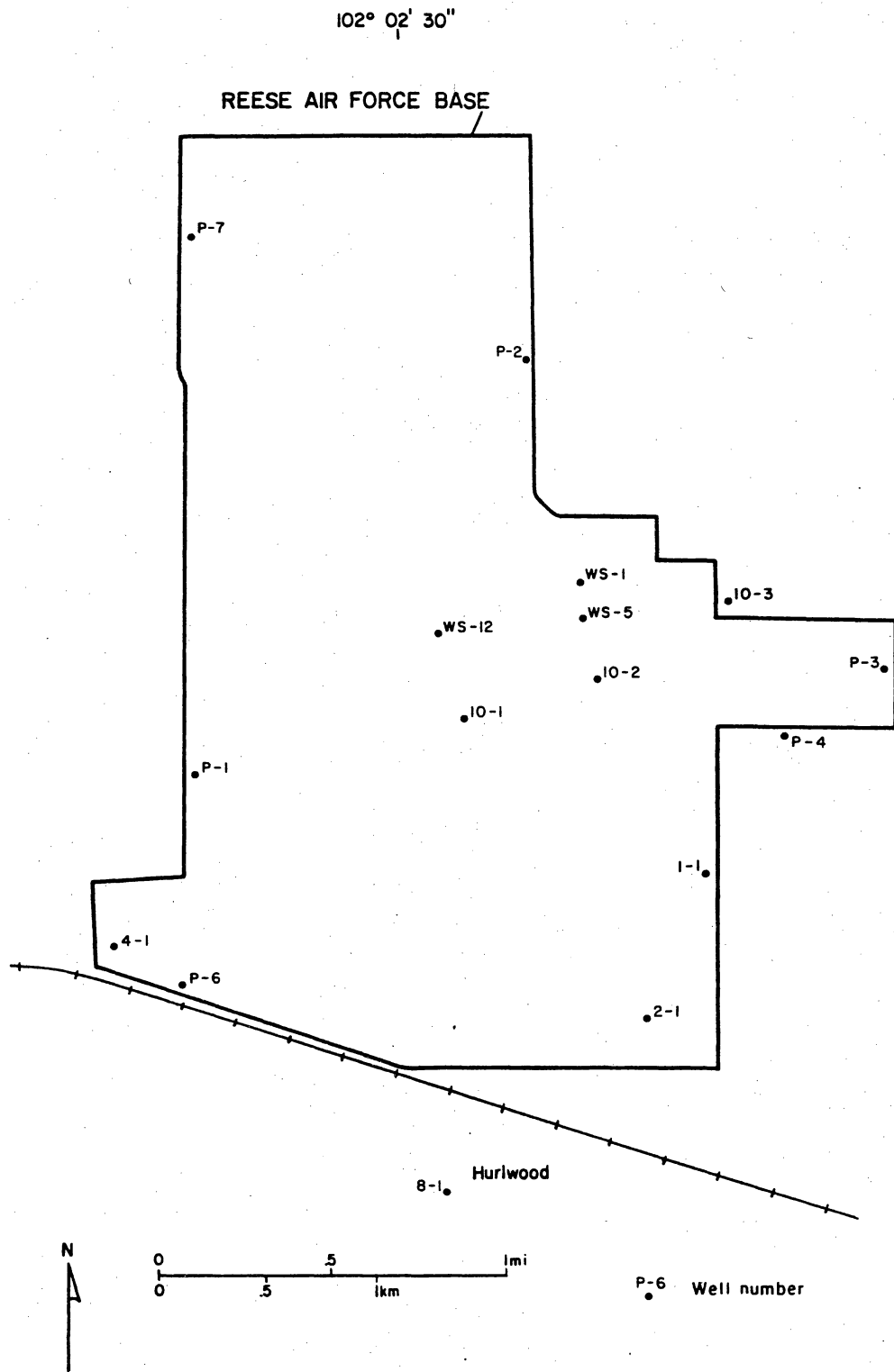

Figure 24. Location of hydrologic monitoring wells on Reese Air Force Base.

Water levels from water supply wells WS-1, WS-5, and WS-12, located in the central part of the base show characteristic semidiurnal fluctuations (figs. 25, 26, and 27), suggesting confining conditions; that is, water-levels in these wells respond to daily fluctuations in barometric pressures (fig. 31). Confined aquifers, which are overlain by a low-permeability confining bed, show a piezometric surface that typically is above the top of the aquifer. The daily cyclic increase in barometric pressure causes the water level to decline in a well that is open to the surface. In the adjacent aquifer, however, the atmospheric load, which is transmitted instantaneously through the confining bed to the interface between the confining bed and the aquifer, is borne partly by the aquifer skeleton. The resulting pressure difference between the water in the well and the pore water in the adjacent aquifer causes water-level fluctuations that are concurrent with the barometric changes and are a constant fraction of the barometric fluctuations.

In a typically unconfined aquifer, barometric pressure variations act uniformly in the open well and on the water table in the adjacent aquifer; thus no differential water-level response occurs between the open well and the adjacent water table. In very deep unconfined aquifers, however, the atmospheric pressure changes may induce water-level fluctuations resulting from the resistance to air flow through the unsaturated zone imposed by materials composing the unsaturated zone and from the compressibility of soil gas (Weeks, 1979). As a result, a temporary pressure imbalance can occur between the water in the well and the pore water in the adjacent aquifer. The associated water-level response in wells screened below the water table in deep unconfined aquifers typically lags behind the barometric-pressure variation. However, the data from the water-supply wells do not indicate a time lag between water levels in the wells (figs. 20, 21, and 22) and the barometric-pressure variation (fig. 31), suggesting mostly confined conditions.

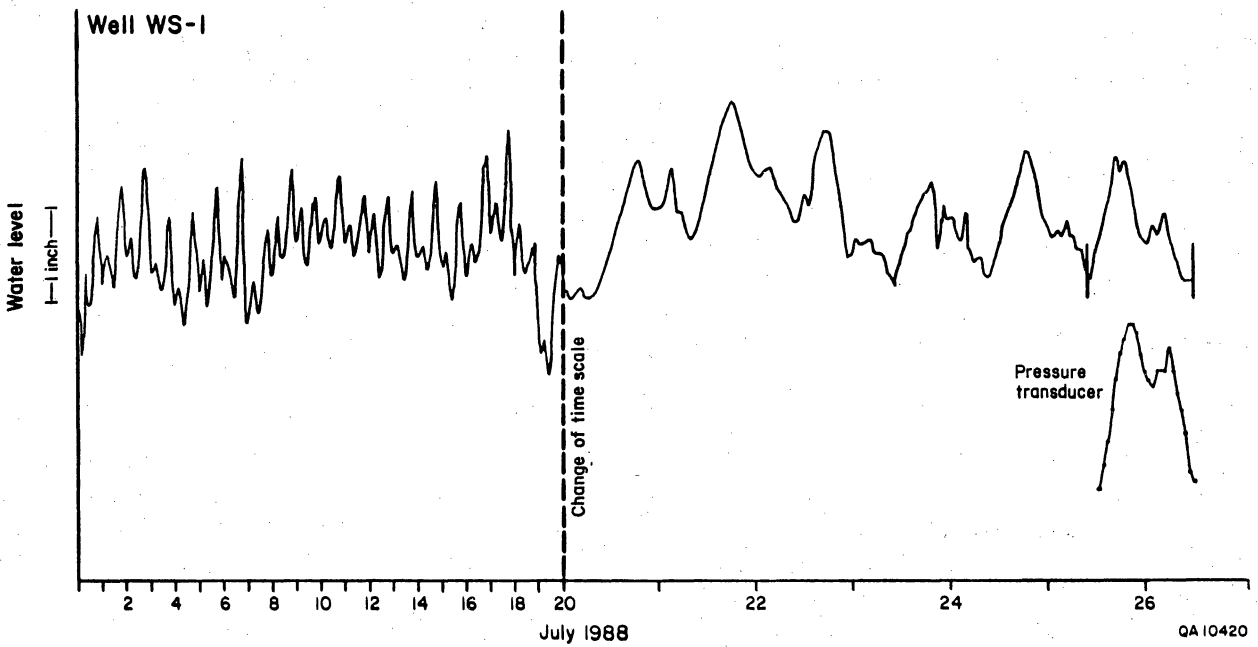

Figure 25. Continuous water-level records, well WS-1. Location of well shown in Figure 24.

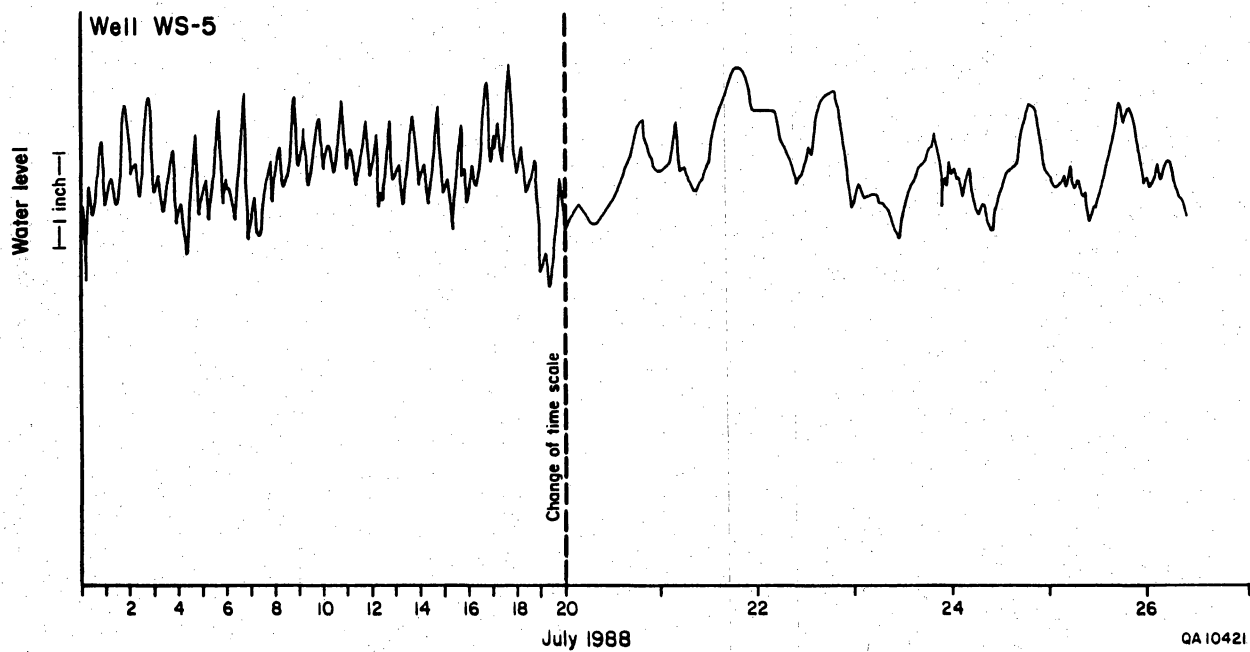

Figure 26. Continuous water-level records, well WS-5. Location of well shown in Figure 24.

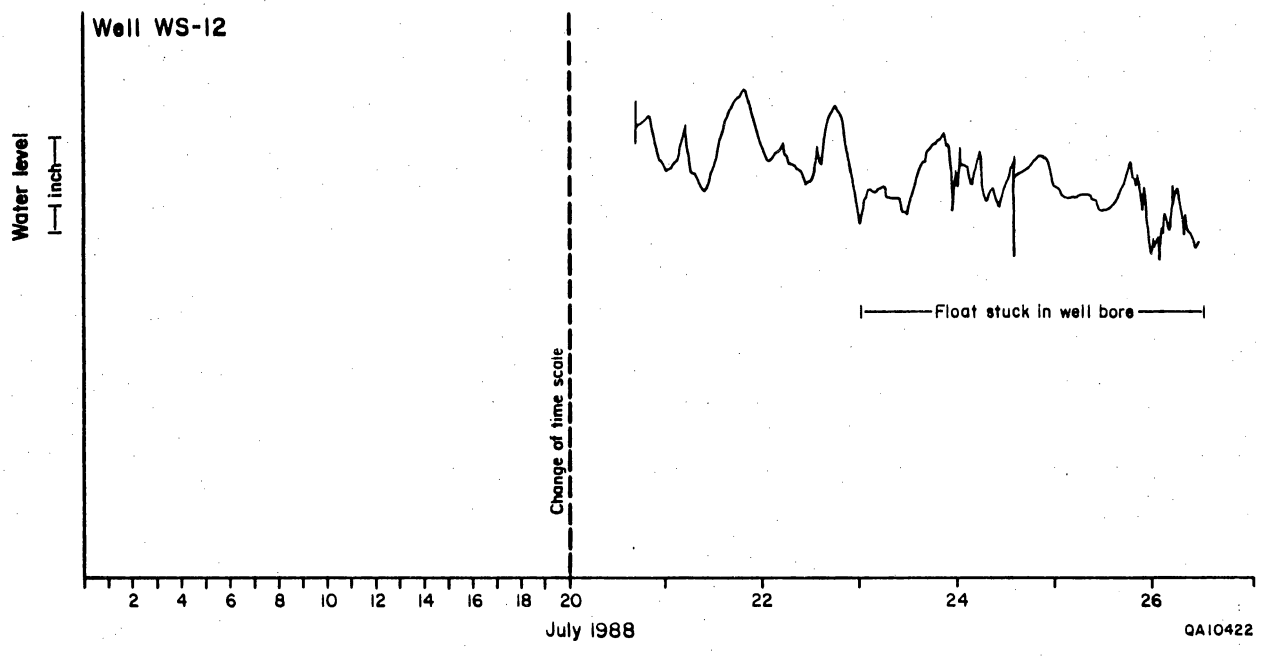

Figure 27. Continuous water-level records, well WS-12. Location of well shown in Figure 24.



Water levels are mostly uniform in wells 1-1, 2-1, and 4-1 (figs. 28, 29, and 30), indicating typically unconfined conditions. On close examination, very slight semidiurnal variations are detected on the hydrographs, which may be related to stratification within the aquifer or may be due to restricted air flow through the unsaturated zone. Mechanical problems may also have affected the movement of the floats in the borehole, because of the small diameter of the well and PVC casing. However, the lack of abrupt changes of the water levels and the relatively smooth curve showing slight semidiurnal variations indicates that the movement of the float was not significantly affected. Although well diameter can theoretically affect the magnitude of water-level variations (Rojstaczer, 1988), there was no significant difference between water-level responses in water-supply wells WS-1 (fig. 25; 18-inch diameter), WS-5 (fig. 26; 12-inch diameter) and WS-12 (fig. 27; 6.5-inch diameter). This suggests that well bore effects are small and could not account for dampening possible water-level variations in the monitoring wells 1-1 (fig. 28), 2-1 (fig. 29), and 4-1 (fig. 30) that have relatively small well diameters of 4 inches.

The abrupt water-level decline observed in well 2-1 between June 30 and July 21 of about 3.5 inches (fig. 29) is probably related to a rise in land surface due to the rise in the lake level, which inundated the ground around the borehole. Water-level measurements made using measuring tape on June 30 and July 21 did not show a noticeable difference in actual depth to water below the top of the well casing. Owing to the inundation, the soils around the well may have swelled, causing a slight elevation rise of the land surface. As a result, the instrument shed in which the Stevens recorder was located increased its elevation relative to the elevation of the well casing, thus recording an apparent water-level decline. The apparent water-level decline occurred immediately following a major rainfall event on July 7 (fig. 31).

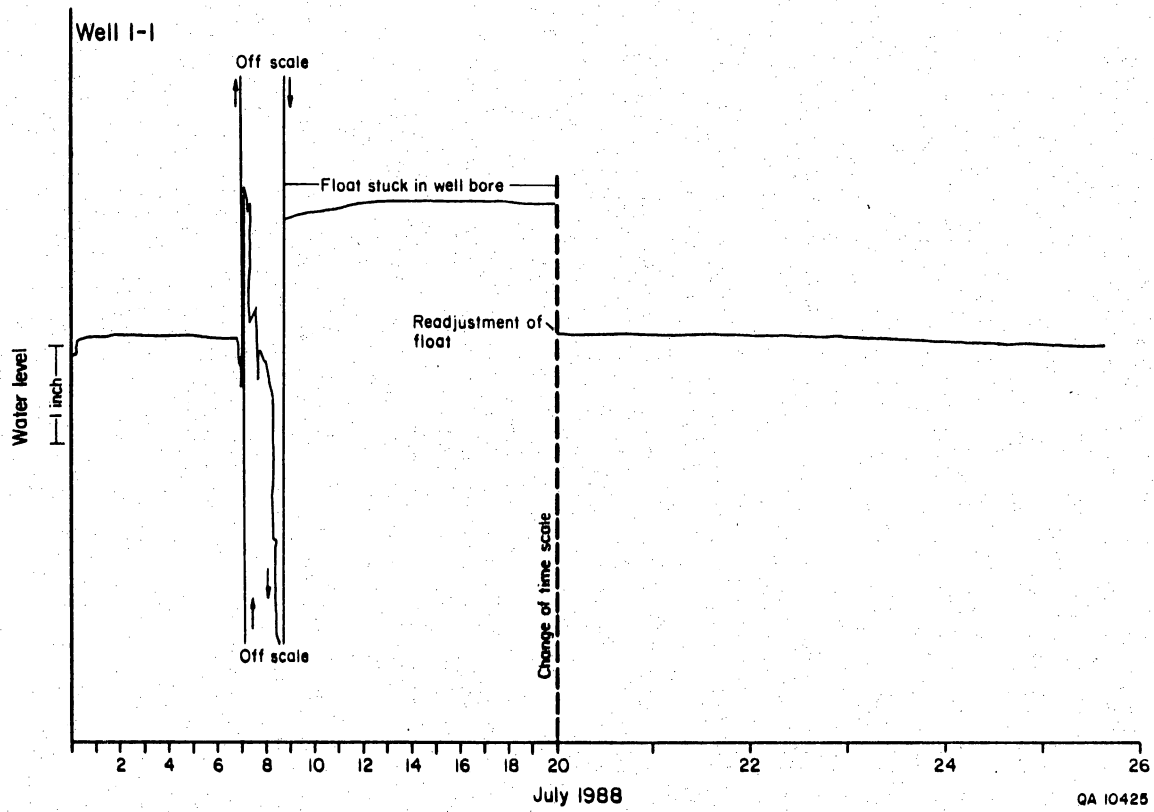

Figure 28: Continuous water-level records, well 1-1. Location of well shown in Figure 24.

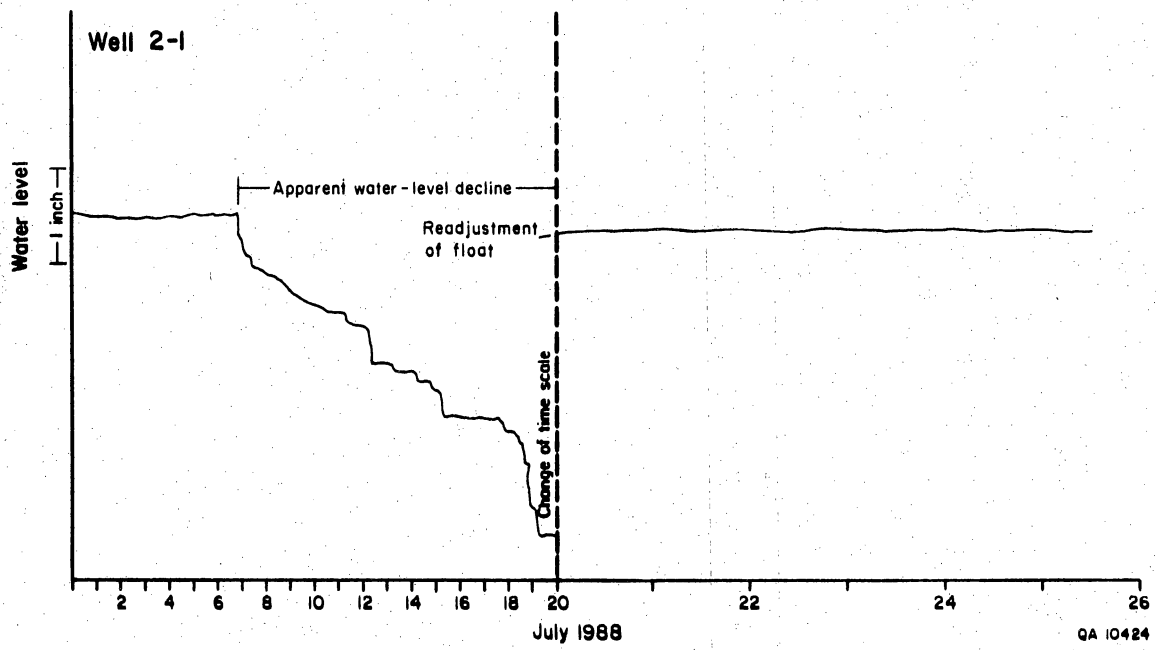

Figure 29. Continuous water-level records, well 2-1. Location of well shown in Figure 24.

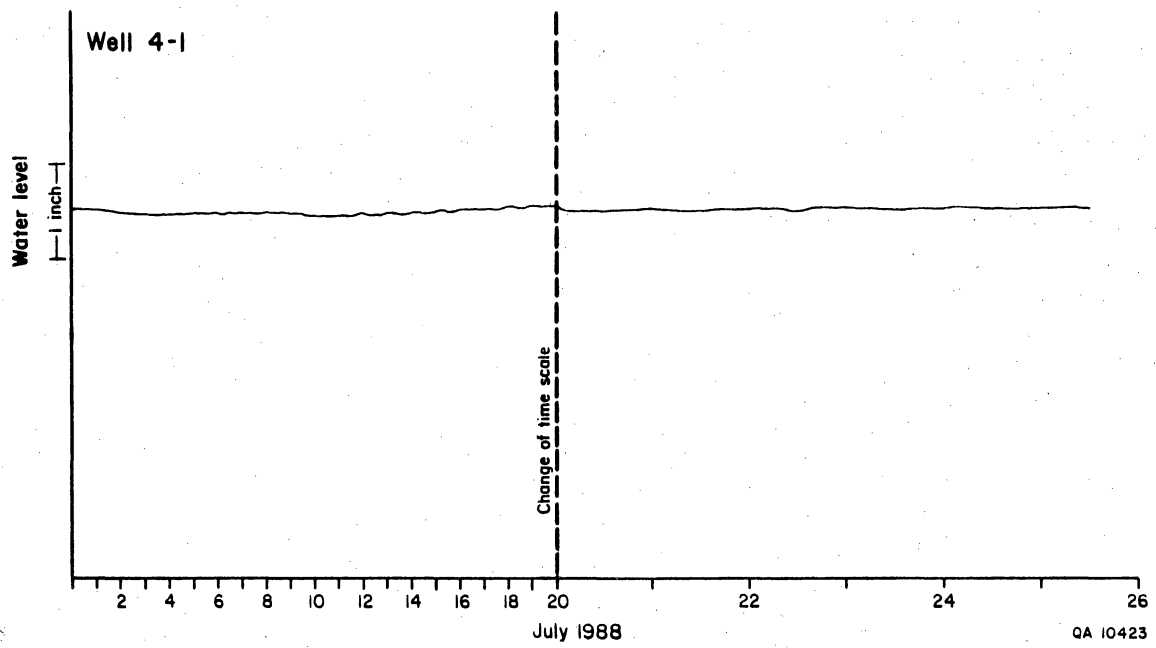

Figure 30. Continuous water-level records, well 4-1. Location of well shown in Figure 24.

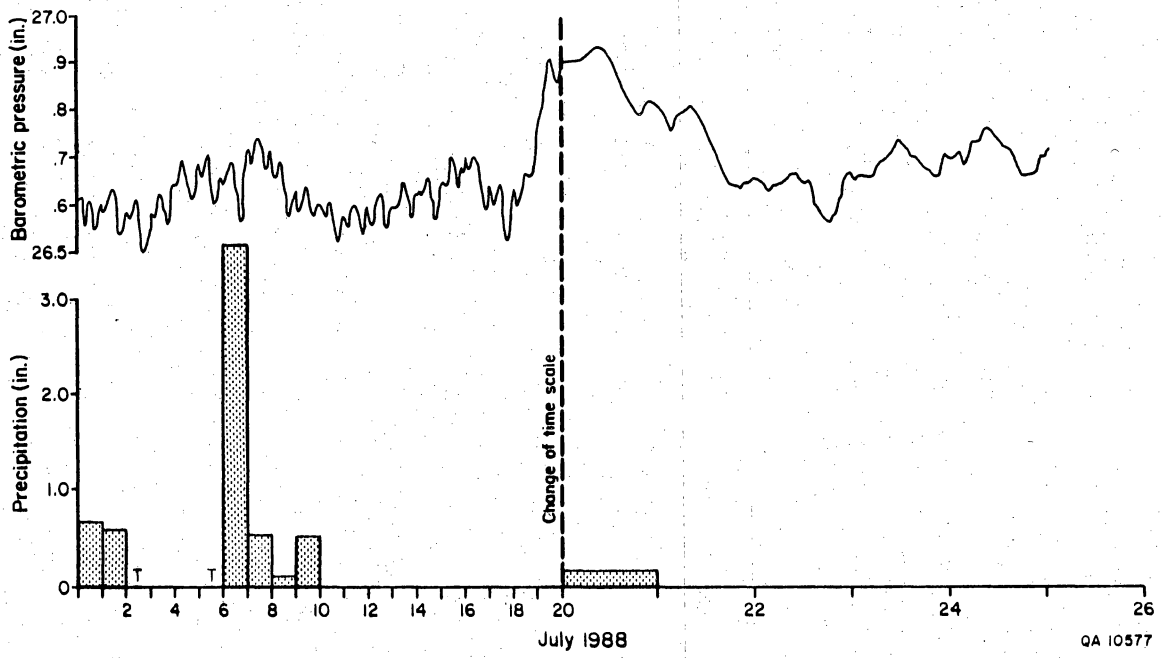

Figure 31. Variations in barometric pressure and amounts of daily precipitation. Data from Reese Air Force Base.

Water levels in the other playa lake (Industrial Lake) rose above the well head in well 1-1 in response to the rainfall event on July 7, allowing surface water to flow into the well bore (fig. 28). Otherwise, water levels in well 1-1 showed only a gradual rise in water level by less than 2 inches, according to individual measurements. Water levels in all wells did not indicate a distinct response to the major rainfall event of 3.59 inches that occurred on July 7. Well 4-1, however, indicates a small rise in water levels after a delay of 4 days. However, it is unclear if this rise is related to the particular recharge event (fig. 30). Water levels in water-supply wells WS-1 and WS-5 also did not show a clear response to the recharge event (figs. 25 and 26), although the hydrograph indicated a general increase following the rainfall event on July 7. Detailed comparison of the hydrographs with barometric pressure variations indicated not only a near-perfect correlation of the peaks existing between the two curves, but also a correspondence in the longer term variations. The general increase in water levels following the rainfall event correlates with a long-term decline in barometric pressure (fig. 31).

Comparison of water-level variations measured both with the Stevens recorder and with a pressure transducer over a 24-hour period in well WS-1 (fig. 25) shows a general agreement of the observed peaks, although the relative magnitude of the variations differed slightly. This discrepancy may be due to calibration of the pressure transducer or interference with the float in the same well. However, it shows that it is possible to identify semidiurnal water-level variations over a 24-hour period using a pressure transducer.

A schematic lithologic profile of water-supply wells WS-1 and WS-5, obtained from the Corps of Engineers, indicates that the water levels are above the elevation of the gravel section, which may be a primary water-bearing section, and may therefore represent a more typically confined scenario, where the overlying eolian fine sands, silts, and clays represent the confining unit. In comparison, lithologic description based on

driller's logs from well 1-1 located at Industrial Lake, well 2-1 located at Sewage Lake, and well 4-1 located at the southwestern corner of the base indicates that water levels in these wells are generally below the elevation of the top of gravels. The lower water-level elevations with respect to the top of the gravels may explain the unconfined conditions in the southern part of the base, whereas the relatively higher water levels in the central part of the base may be indicative of confining conditions. However, the source of lithologic information from the water-supply wells is unknown and discrepancies between driller's logs and core depths require verification by additional geophysical logs.

Water levels in wells WS-1 and WS-5 have increased by about 6 and 13 ft, respectively, between 1942 and 1988, based on static water-level measurements. Assuming that the available lithologic information from the water-supply wells is correct, the depth to the top of gravel in well WS-1 (145 ft) and WS-5 (140 ft) suggests that confining conditions have persisted in the past.

## CONCLUSIONS

Two major geologic facies were observed in the five cores from Reese Air Force Base. Description and interpretation of the cores indicate that sedimentation during the late Tertiary and Quaternary was dominated by eolian processes. The Blackwater Draw Formation and the upper part of the Ogallala Formation consist of very fine sands and coarse silts. Primary sedimentary structures are absent, but pedogenic structures associated with calcic soils are common. These units probably accumulated slowly, having been deposited on the High Plains surface as loess and sand sheets. Data from core holes P-1 and 10-3 also suggest that the lower part of the Ogallala Formation was dominated by eolian processes.

Core holes P-1, 10-3, 1-4, and 002-B4 contain fluvial gravels at similar elevations. Fluvial sediments are also present in core hole P-2 from an elevation of 3,221 ft to the

bottom of the hole. Pond deposits consisting of fine sand to silty clay rhythmites are present from elevations of 3,211 to 3,221 ft. Below 3,211 ft, recovery of core was poor and the actual depth of gravel units is unknown. The position of the gravel interval in each core is plotted in figure 5. The similarity of elevations of the gravel intervals in cores P-1, 10-3, 1-4, and 002-B4 suggests that a blanket of gravel is present beneath most of Reese Air Force Base. The gravel bed is approximately 10 ft thick and dips approximately 10 ft/mile to the southeast. Fluvial deposits intersected in core hole P-2 may or may not be correlative with gravel intervals in other areas.

The distribution of Caprock caliche was not well defined and was identified in only core holes 1 and 3. The Caprock caliche may be present at other coring sites, but may have been lost during drilling as intervals of no recovery.

Hydrologic investigations indicated that, in the vicinity of Reese Air Force Base, water levels in the Ogallala have not changed drastically throughout the last few decades. The potentiometric surface on the base shows convex contours in a downstream direction, indicating some ground-water mounding beneath the base. Water levels in the center of the base rose slightly by about 6 to 13 ft since the 1940's. This may result from the use of some of the playas as industrial ponds. Continuous water-level records indicate typically confined conditions in the three water-supply wells in the center of the base, where water levels in the well respond to changes in barometric pressures. The monitoring wells in the southern part of the base show relatively smooth hydrographs, characteristic of unconfined conditions. The occurrence of both confined and unconfined conditions on the base may be explained by one of two hypotheses. (1) Water-level elevation in each well relative to the top of the water-bearing gravel deposits may control the occurrence of confined conditions; unverified lithologic information from wells WS-1 and WS-5 (where confined conditions are observed) indicates that water levels are generally higher than the top of gravel, whereas water levels in monitoring wells in the southern part of the base (where unconfined conditions



are observed) may be generally lower than top of gravels. Discrepancies between driller's logs and core depths require clarification of the lithologic data. (2) Wells exhibiting unconfined conditions are proximal to water-filled playas, whereas two water-supply wells are farther from playas. An exception is water-supply well 12, which is located near an infilled playa in the center of Reese Air Force Base. This playa may not be hydrologically significant. Although water levels in wells next to water-filled playas did not show an immediate response to major rainfall events, the regional hydrologic data and the continuous water-level data suggest the potential for focused recharge through playas or areas where the upper caliche layer is missing. This suggests that the playas are important points of recharge.

The distribution of contamination does not indicate a direct relationship between the degree of confinement and the occurrence of contaminants. Water-supply wells WS-1, WS-5, and WS-12 show confined conditions, but contamination is present only in WS-5 and WS-12 (figs. 1, 24, and 25). The presence of confined and unconfined conditions, however, is important, and its relative significance is dependent upon hypothesis (1) or (2). If hypothesis (1) is correct (water-level elevation relative to the gravels), then the gravels are the major water-bearing strata and their distribution is critical to the contaminant migration in the aquifer. If hypothesis (2) is correct (confined and unconfined conditions are controlled by proximity to playa recharge), then geographic distribution of the caliche and points of recharge (playa lakes) is a critical parameter. Before ground water can become contaminated, contaminants must leak through the caliche. Migration of contaminants may be along dip direction at the upper surface of the caliche independent of the regional ground-water flow direction until a point of leakage is reached where contaminants can migrate downward into the water-bearing units.

## PROPOSED FUTURE STUDIES

Future hydrologic studies need to test the two hypotheses of aquifer confinement within the Ogallala beneath the base and their importance to the contaminant distribution in the aquifer. Three studies are recommended.

### 1. Geologic investigations

Core from five wells at Reese Air Force Base have been described. Resistivity and gamma-ray logs are available for these same wells. The geophysical logs should be closely compared with the core and core descriptions in order to characterize log responses for various sediment types and cements. If these comparisons are made, then logs from wells drilled but not cored can be interpreted with a greater confidence by correlation to logs of cored wells. This would permit a more complete characterization of the lateral distribution of facies beneath the base. The most critical facies package for more detailed characterization is the gravel beds observed at similar elevations in four of the five cores described. These gravels may be the major water-transmission zone for the Ogallala Formation beneath the base and therefore a possible conduit for contaminant migration.

To complete the characterization of Ogallala sediments and to aid in determining the distribution of porosity in these sediments, approximately 25 grain-size and percent-carbonate analyses should be completed. In addition, we recommend thin-section analyses of approximately 20 selected samples to determine porosity distribution.

### 2. Controls on aquifer confinement

The applicability of pressure transducers for identifying semidiurnal variations in the range of less than 1 inch has been successfully tested in this study. For future work, it is proposed to use pressure transducers for all monitoring wells on a 24-hour basis in order to delineate confined and unconfined areas of the Ogallala aquifer. The results

would then be compared with water-level measurements and their relative elevation to the top of water-bearing gravel deposits. In addition, the data would also be studied as to a well's proximity to the playas on the base.

### 3. Contaminant recharge via playa recharge

The potential for contaminant migration to the Ogallala aquifer through playas or areas where the upper caliche layer is absent should be studied by determining the areal distribution of the upper caliche layer and the hydrologic properties of the caliche beneath the playas. The occurrence of caliche along a traverse crossing a playa and interplaya area could be identified using ground-penetrating radar or surface geophysical techniques, such as shallow seismic penetration or geoelectric methods, in addition to selected boreholes to be drilled. These boreholes should be augered to a depth of about 50 ft. or possibly down to the water table. Lithologic characterization based on drill cuttings can be correlated with patterns observed from ground-penetrating radar.

In addition, soil samples taken from these boreholes should be tested for contaminant concentrations and moisture content. Neutron probes will then be used to determine continuous moisture profiles in the boreholes. Geophysical log data will be calibrated to measured moisture contents from the analyzed soil samples to obtain quantitative moisture profiles for the different wells. Lateral and vertical variation of contaminants and moisture content in different boreholes along the traverse across playas and interplaya areas will supply detailed information on potential recharge and contaminant migration to the Ogallala Formation. The importance of the confined or unconfined conditions observed from the continuous water-level recorder data and proximity to playas would also be investigated. Numerical simulations of unsaturated flow conditions beneath the playas can be used to examine recharge rates and potential contaminant migration to the Ogallala through this mechanism. The relationship between

geologic characteristics and moisture distribution in the unsaturated zone can be used to qualitatively evaluate contaminant transport through the unsaturated zone. Of particular importance is the potential for deviation of the generally vertical migration pathways due to tight caliche horizons, where contaminants can move laterally along the structural surface of the confining horizon before migrating vertically through sections where the caliche layers are fractured or partially absent.

### ACKNOWLEDGMENTS

This program was developed with the help of Dan Wyatt and Catherine Hitchins, Randolph Air Force Base, San Antonio, Texas. Core material and meteorologic data were supplied by Dan Gillum and Gary Gumm of Reese Air Force Base, Lubbock, Texas. The help of Clif Warren and Andy Obrachta, U.S. Corps of Engineers, Tulsa, Oklahoma, is appreciated.

## REFERENCES

- Bomar, G. W., 1983, Texas weather: Austin, University of Texas Press, 265 p.
- Goddard, E. M., Trask, P. D., DeFord, R. K., Roue, O. N., Singwald, U. T., and Overbeck, R. M., 1948, Rock Color Chart: Boulder, Colorado, Geological Society of America.
- Gustavson, T. C., and Holliday, V. T., 1988, Depositional and pedogenic characteristics of the Quaternary Blackwater Draw and Tertiary Ogallala Formations, Texas Panhandle and eastern New Mexico: The University of Texas at Austin, Bureau of Economic Geology Open-File Report OF-WTWI-1985-23, Rev. 1, 112 p.
- Gustavson, T. C., and Winkler, D. A., 1988, Depositional facies of the Miocene-Pliocene Ogallala Formation, northwestern Texas and eastern New Mexico: *Geology*, v. 16, p. 203-206.
- Holliday, V. T., 1988, Mt. Blanco revisited: Soil-geomorphic implications for the ages of the upper Cenozoic Blanco and Blackwater Draw Formations: *Geology*, v. 16, p. 505-508.
- Kier, R. S., Stecher, S., and Brandes, R. J., 1984, Rising ground-water levels: Proceedings, Ogallala aquifer symposium II: Lubbock, Texas, Texas Tech University, Water Resources Center, p. 416-439.
- Knowles, T., Nordstrom, P., and Klemt, W. B., 1984, Evaluation of the ground water resources of the High Plains of Texas: Texas Department of Water Resources Report 288, 179 p.

- Lotspeich, F. B., Lehman, O., Hauser, V. L., and Stewart, B. A., 1971, Hydrogeology of a playa near Amarillo, Texas: U.S. Department of Agriculture, Agricultural Resources Service, Technical Report No. 10.
- Machette, M. N., 1985, Calcic soils of the southwestern United States, in Weide, D. L., ed., Soils and the Quaternary geology of the southwestern United States: Geological Society of America Special Paper 203, p. 1-21.
- Nelson, R. W., Logan, W. J., and Weller, E. C., 1983, Playa wetlands and wildlife on the southern Great Plains: a characterization of habitat: U.S. Department of the Interior, Fish and Wildlife Service.
- Ries, G. V., 1981, Preliminary work on calcrete horizon maps with infiltration rates: Texas Tech University, Master's thesis, 158 p.
- Rojstaczer, Stuart, 1988, Determination of fluid flow properties from the response of water levels in wells to atmospheric loading: *Water Resources Research*, v. 24, no. 11, p. 1927-1938.
- Stone, W. J., 1984, Preliminary estimates of Ogallala aquifer recharge in the unsaturated zone, Curry County, New Mexico, in Proceedings, Ogallala aquifer symposium II: Lubbock, Texas, Texas Tech University, Water Resources Center, p. 376-391.
- Weeks, E. P., 1979, Barometric fluctuations in wells tapping deep unconfined aquifers: *Water Resources Research*, v. 15, no. 5, p. 1167-1176.

Winkler, D. A., 1985, Stratigraphy, vertebrate paleontology, and depositional history of the Ogallala Group in Blanco and Yellowhouse Canyons, northwestern Texas: The University of Texas at Austin, Ph.D. dissertation, 243 p.

Wood, W. W., and Osterkamp, W. R., 1984, Recharge to the Ogallala aquifer from playa lake basins on the Llano Estacado (an outrageous proposal?), in Proceedings, Ogallala aquifer symposium II: Lubbock, Texas, Texas Tech University, Water Resources Center, p. 337-349.

## APPENDIX I

Descriptions of core from the Tertiary Ogallala and Quaternary Blackwater Draw Formations, Reese Air Force Base, Lubbock County, Texas. Description of Blackwater Draw Formation from 0-13 ft and 0-10 ft for core holes P-1 and P-2, respectively, is based on core collected with Bureau of Economic Geology Giddings Soil Probe. All other core descriptions based on core were provided by the U.S. Army Corps of Engineers. Cslt=coarse silt; vbsd=very fine sand. Sediment colors were determined by comparison to the rock-color chart (Goddard and others, 1948).

### Core Hole P-1, Area 006

Depth in feet	Description
<b>Quaternary Blackwater Draw Formation</b>	
0-5.5	Surface soil, brown vbsd to cslt over a white, uncemented vbsd to cslt.
5.5-13	Silty sand, light-brown, vbsd to cslt, CaCO <sub>3</sub> filaments and nodules
13-23	No recovery
<b>Miocene-Pliocene Ogallala Formation</b>	
23-25	Calcrete, grayish-orange-pink (5YR 7/2), locally pisolitic, vbsd to cslt clasts floating in CaCO <sub>3</sub> matrix, moderately to well cemented with CaCO <sub>3</sub> , root tubules to 0.1 mm.
25-26.5	No recovery
26.5-27.5	Calcrete, grayish-orange-pink (5YR 7/2), vbsd to cslt clasts floating in CaCO <sub>3</sub> matrix, moderately to well cemented with CaCO <sub>3</sub> .
24.5-63	Silty sandstone, grayish-orange-pink (5YR 7/2) to light-brown (5YR 6/4), vbsd to cslt, uncemented to moderately cemented with CaCO <sub>3</sub> , root tubules to 0.2 mm, CaCO <sub>3</sub> filaments, CaCO <sub>3</sub> -cemented pinkish-gray nodules to 4 cm (1.6 inches) below 45 ft.
63-89	Silty sandstone, grayish-orange-pink (5YR 7/2) to light-brown (5YR 8/1) (5YR 6/4), vbsd to cslt, uncemented to moderately cemented with



CaCO<sub>3</sub>, CaCO<sub>3</sub> nodules to 3 cm (1.2 inches), root tubules, locally silicified, silica cement has replaced CaCO<sub>3</sub> cement and nodules, siliceous nodules pale brown (5YR 5/2).

- 90-92 Pebbly silty sand to pebble conglomerate, carbonate cemented, clasts composed of quartzites, vein quartz, and metasediments.
- 92-93 No recovery
- 93-94.5 Loose pebbles retained
- 94.5-97 No recovery
- 97-100 Loose pebbles retained
- 100-101 Silty sandstone, light-brown (5YR 6/4), vbsd to csilt, uncemented to poorly cemented with CaCO<sub>3</sub>.
- 101-112 No recovery
- 112-115 Silty sandstone, light-brown (5YR 6/4), vbsd to csilt, uncemented to poorly cemented with CaCO<sub>3</sub>, 112-112.5 ft mottled with black (N1) (manganese?) stain.
- 115-117 No recovery
- 117-120 Silty sandstone, light-brown (5YR 6/4), vbsd to csilt, uncemented to poorly cemented with CaCO<sub>3</sub>.
- 120-122 No recovery
- 122-123.5 Silty sandstone, light-brown (5YR 6/4), vbsd to csilt, uncemented to poorly cemented with CaCO<sub>3</sub>.
- 123.5-131 No recovery
- 131-145 Silty sandstone, light-brown (5YR 6/4), vbsd to csilt, uncemented to poorly cemented with CaCO<sub>3</sub>, CaCO<sub>3</sub>-cemented nodules from 130-135 ft, clay silt lamina at 138 ft, CaCO<sub>3</sub>-cemented nodules from 131-136 ft, CaCO<sub>3</sub> lenses at 144 ft, silt/clay content increases from 143-145 ft.
- 145-147 No recovery
- 147-149 Silty clayey sandstone, light-brown (5YR 6/4) vbsd to silt, poorly cemented with CaCO<sub>3</sub>.
- 150-152 No recovery
- 152-159.5 Silty sandstone, light-brown (5YR 6/4) vbsd to csilt, poorly cemented with CaCO<sub>3</sub>, CaCO<sub>3</sub>-cemented nodules from 157-159.5.
- 159.5 Middle Tertiary unconformity

### **Cretaceous Duck Creek (?) Shale**

159.5-200 Shale, thin (6-12 cm [2.4-4.7 inches]) interbedded sandstone and limestone beds, gray to black, rare flaser beds, Gryphea sp. at 161 ft.

Core Hole P-2

Depth in feet	Description
<b>Quaternary Blackwater Draw Formation</b>	
0-6.5	Surface soil, pale brown (5YR 5/2) vbsd to csilt over white vbsd to csilt, uncemented
6.5-10	Silty sand, light-brown (5YR 6/4) vbsd to csilt, CaCO <sub>3</sub> filaments and nodules, uncemented
19	Miocene-Pliocene Ogallala Formation
19-25	Silty sandstone, moderate-reddish-brown (10R 4/6) to light-brown (5YR 6/4), vbsd to csilt, uncemented to poorly cemented with CaCO <sub>3</sub> , CaCO <sub>3</sub> -cemented nodules, CaCO <sub>3</sub> filaments, root tubules.
25-38	No recovery
38-42	Silty sandstone, light-brown (5YR 6/4) vbsd to csilt, uncemented to moderately cemented with CaCO <sub>3</sub> , CaCO <sub>3</sub> cemented nodules, root tubules.
42-43	Missing core
43-96	Silty sandstone, light-brown (5YR 6/4) vbsd to csilt, uncemented to well-cemented with CaCO <sub>3</sub> , CaCO <sub>3</sub> cemented nodules, 63.5 to 69 ft CaCO <sub>3</sub> nodules form a ladder structure, 69 ft silicified zone, CaCO <sub>3</sub> cement and nodules replaced by silica, root tubules.
96-106	Loose cobbles, pebbles and granules recovered, cobbles to 6 cm (2.4 inches).
106-116	Silt-silty clay rhythmites, moderate-reddish-brown (10R 4/6) silty clay laminae grade upward into pale-red silt laminae.
116-123	No recovery
123-126	Uncemented gravel clasts (probably washed into hole from above) overlie silty sandstone. Silty sandstone, grayish-orange-pink vbsd to csilt, uncemented to poorly cemented by CaCO <sub>3</sub> , CaCO <sub>3</sub> cemented nodules.
126-133	No recovery
133-140	Possibly remnants of basal gravel of debris that collapsed into hole.
140	Middle Tertiary unconformity

**Cretaceous Duck Creek(?) Shale**

140-150 Shale, laminated, moderate-yellowish-brown (10YR 5/4) to light-olive brown (5Y 5/6).

Core Hole 10-3

Depth in feet	Description
<b>Quaternary Blackwater Draw Formation</b>	
14-15.5	Sandy silt, light-brown(5YR 6/4), not cemented, CaCO <sub>3</sub> nodules and filaments.
15.5-20	No recovery
20-21.5	Sandy silt, light-brown(5YR 6/4), not cemented, CaCO <sub>3</sub> nodules and filaments.
21.5-35	Silty sandstone, light-brown (5YR 6/4) vbsd to csilt, uncemented to moderately cemented with CaCO <sub>3</sub> . CaCO <sub>3</sub> cemented nodules to 4 cm (1.6 inches), root tubules.
<b>Miocene-Pliocene Ogallala Formation</b>	
35-50	Silty sandy calcrete, light-brown (5YR 6/4), moderately-to-well cemented with CaCO <sub>3</sub> , vbsd to csilt grains locally float in CaCO <sub>3</sub> matrix, ladder structure resulting from coalescing CaCO <sub>3</sub> nodules, root tubules, solution pits in calcrete.
50-96	Silty sandstone, light-brown (5YR 6/4) vbsd to csilt, moderately-to-well cemented with CaCO <sub>3</sub> , CaCO <sub>3</sub> cemented nodules to 4 cm (1.6 inches), root tubules, large tubules at 83 ft, CaCO <sub>3</sub> cement and nodules silicified at 55, 63, and 83 ft.
96-111	Sandy conglomerate, coarse sand to pebble gravel, poorly to well-cemented by CaCO <sub>3</sub> .
111-120	Crossbedded sand, laminated silty clay and clay, moderate brown (5YR 4/4), uncemented to poorly cemented by CaCO <sub>3</sub> .
120-131	No recovery
131-158	Silty sandstone, moderate-yellowish-brown (10YR 5/4) vbsd to csilt, uncemented to poorly cemented with CaCO <sub>3</sub> , cemented nodules cemented with CaCO <sub>3</sub> , black streaks (manganese?).
158-169	Silty sandstone, moderate-yellowish-brown (10YR 5/4) vbsd to silt or clay, uncemented to poorly cemented with CaCO <sub>3</sub> , CaCO <sub>3</sub> filaments.
169	Middle Tertiary unconformity
169-180	Cretaceous Duck Creek (?) Shale

Core Hole 1-4  
(Core 001-B4)

Depth in feet	Description
0-21.5	No recovery
<b>Miocene-Pliocene Ogallala Formation</b>	
0-25.3	Silty sand, pinkish-gray (5YR 8/1) to light-brownish-gray (5YR 6/1), vbsd to cslt, CaCO <sub>3</sub> nodules, root tubules, uncemented.
25.3-83.5	Silty sandstone, light-brownish-gray (5YR 6/1) to grayish-orange-pink (5YR 7/2), vbsd to cslt, poorly to moderately cemented with CaCO <sub>3</sub> , CaCO <sub>3</sub> nodules, root tubules.
83.5-88.2	Coarse gravel, clasts up to 5 cm (2 inches) in longest dimension

Core Hole 002-B4  
(core hole is 4 ft away from Well 2-2)

Depth in feet	Description
0-20	No recovery
<b>Miocene-Pliocene Ogallala Formation</b>	
20-54.5	Silty sandstone, light-brownish-gray (5YR 6/1), vbsd to csilt, moderately- to well-cemented with $\text{CaCO}_3$ , $\text{CaCO}_3$ nodules, root tubules. At 53 ft, $\text{CaCO}_3$ cement is replaced by siliceous cement to form pale-brown (5YR 5/2) siliceous nodules.
54.5-66.7	No recovery
66.7-82	Silty sandstone, grayish-orange-pink (5YR 7/2), vbsd to csilt, moderately- to well-cemented with $\text{CaCO}_3$ , $\text{CaCO}_3$ nodules, siliceous nodules.
82-85	Coarse gravel