

Annual Report

ENVIRONMENTAL BASELINE MONITORING IN THE AREA OF GENERAL CRUDE OIL-
DEPARTMENT OF ENERGY PLEASANT BAYOU NUMBER 2--
A GEOPRESSURED GEOTHERMAL TEST WELL--1980

by

Thomas C. Gustavson
Rory C. Howard
Douglas McGooley

Prepared for
U.S. Department of Energy
Division of Geothermal Energy

under Contract Number DE-AC08-79ET27111

Bureau of Economic Geology
The University of Texas at Austin
Austin, Texas 78712

W. L. Fisher, Director

1982

CONTENTS

Introduction and Technical Report

	Page
Introduction	1
Basic objectives of baseline subsidence	5
Summary of seismicity before November 1, 1980	6
Objective of air quality monitoring	23
Objective of water quality monitoring	38
Acknowledgments	50
References	51
Appendix I: Air quality monitoring	55
Appendix II: Microseismic monitoring	183

Figures

1. Location of Department of Energy-General Crude Oil Pleasant Bayou #1 and #2 geothermal test wells and environmental monitoring facilities	2
2. Spectral comparison of a background noise sample	7
3. Epicenter locations of seismic shot activity	10
4. Typical seismic shot event, November 3, 1979	11
5. Typical surface wave event, November 4, 1979	12
6. Typical surface wave event, February 5 and 6, 1980	14
7. Structure contours on base of Miocene and cumulative epicenter map for natural events as of October 31, 1980	16
8. Structure contours on arbitrary seismic reflector just below base of Alta Loma sand and cumulative epicenter map for natural events as of October 31, 1980	17
9. Location of ground-water monitoring wells and multiliquid tiltmeter line	22

10a.	Daily particulate concentration averages in micrograms per cubic meter for January through May	24
10b.	Daily particulate concentration averages in micrograms per cubic meter for June through October	25
11a.	Daily sulfur dioxide concentration averages in micrograms per cubic meter for January through May	26
11b.	Daily sulfur dioxide concentration averages in micrograms per cubic meter for June through October	27
11c.	Sulfur dioxide. Five maximum 1-hour sliding averages per month in micrograms per cubic meter for January through October	28
12a.	Daily methane concentration averages in micrograms per cubic meter for January through February	29
12b.	Daily methane concentration averages in micrograms per cubic meter for March through May	30
12c.	Daily methane concentration averages in micrograms per cubic meter for June through August	31
12d.	Daily methane concentration averages in micrograms per cubic meter for September through October	32
12e.	Methane. Five maximum 3-hour sliding averages per month in micrograms per cubic meter for January through April	33
12f.	Methane. Five maximum 3-hour sliding averages per month in micrograms per cubic meter for May through August	34
12g.	Methane. Five maximum 3-hour sliding averages per month in micrograms per cubic meter for September through October	35
13a.	Daily hydrogen sulfide concentration averages in micrograms per cubic meter for January through October	36
13b.	Hydrogen sulfide. Five maximum 1-hour sliding averages per month in micrograms per cubic meter for January through October	37

Tables

1.	Seismicity by month	8
2.	Disposal well, Pleasant Bayou	19
3.	Chocolate Bayou, water quality analyses	39
4.	Pleasant Bayou geothermal test well area, shallow ground-water analyses	45

Appendix I:

Air Quality Monitoring

I.	General description of air monitoring program	57
II.	Description of instrument systems (January-February)	60
	A. Air quality instrumentation	60
	1. Description	60
	2. Calibration	61
	B. Data acquisition system	62
III.	January methane bag sampling program	64
IV.	Operating time analysis	65
V.	Data presentation and summary	68
VI.	February methane bag sampling program	79
VII.	Description of instrument systems (March-October)	90
	A. Air quality instrumentation	90
	1. Description	90
	2. Calibration	91
	B. Data acquisition system	92
	1. Floppy disk	93
VIII.	March methane bag sampling program	94
IX.	April methane bag sampling program	105
X.	May methane bag sampling program	116
XI.	June methane bag sampling program	127
XII.	July methane bag sampling program	138
XIII.	August methane bag sampling program	149
XIV.	September methane bag sampling program	160
XV.	October methane bag sampling program	171

Appendix I Figures

I.	Ambient air monitoring system I	58
II.	Air monitoring site	59

Appendix I Tables

January

1.	Downtime hours for Chocolate Bayou, Texas, 1980	66
2.	Federal and Texas State ambient air quality standards	71
3.	Daily averages for January 1-31, 1980	72
4.	The five maximum independent sliding averages for January 1-31, 1980	74
5.	Hourly averages for January 1-31, 1980	76

February

6.	Downtime hours for Chocolate Bayou, Texas, 1980	80
7.	Federal and Texas State ambient air quality standards	82
8.	Daily averages for February 1-29, 1980	83
9.	The five maximum independent sliding averages for February 1-29, 1980	85
10.	Hourly averages for February 1-29, 1980	87

March

11.	Downtime hours for Chocolate Bayou, Texas, 1980	95
12.	Federal and Texas State ambient air quality standards	97
13.	Daily averages for March 1-31, 1980	98
14.	The five maximum independent sliding averages for March 1-31, 1980	100
15.	Hourly averages for March 1-31, 1980	102

April

16.	Downtime hours for Chocolate Bayou, Texas, 1980	106
17.	Federal and Texas State ambient air quality standards	108
18.	Daily averages for April 1-30, 1980	109
19.	The five maximum independent sliding averages for April 1-30, 1980	111
20.	Hourly averages for April 1-30, 1980	113

May

21.	Downtime hours for Chocolate Bayou, Texas, 1980	117
22.	Federal and Texas State ambient air quality standards	119
23.	Daily averages for May 1-31, 1980	120
24.	The five maximum independent sliding averages for May 1-31, 1980	122
25.	Hourly averages for May 1-31, 1980	124

June

26.	Downtime hours for Chocolate Bayou, Texas, 1980	128
27.	Federal and Texas State ambient air quality standards	130
28.	Daily averages for June 1-30, 1980	131
29.	The five maximum independent sliding averages for June 1-30, 1980	133
30.	Hourly averages for June 1-30, 1980	135

July

31.	Downtime hours for Chocolate Bayou, Texas, 1980	139
32.	Federal and Texas State ambient air quality standards	141
33.	Daily averages for July 1-31, 1980	142
34.	The five maximum independent sliding averages for July 1-31, 1980	144
35.	Hourly averages for July 1-31, 1980	146

August

36. Downtime hours for Chocolate Bayou, Texas, 1980 150

37. Federal and Texas State ambient air quality standards 152

38. Daily averages for August 1-31, 1980 153

39. The five maximum independent sliding averages for
August 1-31, 1980 155

40. Hourly averages for August 1-31, 1980 157

September

41. Downtime hours for Chocolate Bayou, Texas, 1980 161

42. Federal and Texas State ambient air quality standards 163

43. Daily averages for September 1-30, 1980 164

44. The five maximum independent sliding averages for
September 1-30, 1980 166

45. Hourly averages for September 1-30, 1980 168

October

46. Downtime hours for Chocolate Bayou, Texas, 1980 172

47. Federal and Texas State ambient air quality standards 174

48. Daily averages for October 1-31, 1980 175

49. The five maximum independent sliding averages for
October 1-31, 1980 177

50. Hourly averages for October 1-31, 1980 179

Appendix II:

Microseismic Monitoring

Introduction 185

1.1 Background and purpose of the monitoring program 185

Data collection and analysis	186
2.1 Field measurements	186
2.2 Data analysis procedures	188
Observed activity	192
3.1 Signals failing criteria to be identified as microearthquakes	192
3.2 Signals observed which could be identified as microearthquakes	195
Discussion	197
January microseismic monitoring results	199
February microseismic monitoring results	206
March microseismic monitoring results	217
April microseismic monitoring results	217
May microseismic monitoring results	221
June microseismic monitoring results	221
July microseismic monitoring results	230
August microseismic monitoring results	230
September microseismic monitoring results	236
October microseismic monitoring results	239
References	243

Appendix II Figures

1. Location of sensor sites of Brazoria County field program	187
2. Block diagram of the Brazoria County monitoring system	189
3. Velocity response of the monitoring systems (from film)	190
4. Tentative classification of events by source type	191
5. Brazoria County seismicity and local thunder activity	193
6. Cumulative epicenter map for natural events as of May 30, 1980	194

7.	Epicenter map for possible microearthquake events as of May 30, 1980	196
8.	Background noise samples with microseismic event	198
9.	Natural event epicenters with growth faults at 15,000 ft depth	201
10.	Cumulative frequency of occurrence vs. magnitude for November 1979 and January 1980	205
11.	Typical record from night of February 5-6	207
12.	Epicenters determined for February 1980	208
13.	Epicentral regions and station locations	216
14.	March 1980 epicenters	218
15.	April 1980 epicenters	222
16.	Epicenter map for May 1980	223
17.	Cumulative epicenter map for natural events as of May 30, 1980	227
18.	Epicenter map for June 1980	228
19.	Epicenter map for July 1980	232
20.	Daily histogram of all activity classified as hydraulic fracturing or natural	233
21.	Epicenter map for August 1980	235
22.	Epicenter map for September 1980	238
23.	Epicenter map for October 1980	242

Appendix II Tables

1.	Site coordinates	186
2.	January 1980 microseismicity by region	200
3.	Microseismic events January 1980	202
4.	"Impulsive event" summary	206
5.	Microseismic events February 1980	209
6.	Microseismic events March 1980	219

7.	Microseismic events April 1980	220
8.	Microseismic events May 1980	224
9.	Microseismic events June 1980	229
10.	Microseismic events July 1980	231
11.	Microseismic events August 1980	234
12.	Microseismic events September 1980	237
13.	Microseismic events October 1980	240

INTRODUCTION

A program to monitor baseline air and water quality, subsidence, microseismic activity, and noise in the vicinity of Brazoria County geopressured geothermal test wells, Pleasant Bayou #1 and #2, has been underway since March 1978 (fig. 1). The research findings for earlier work, including the results of an initial first-order leveling survey completed by Teledyne Geotronics, a preliminary microseismicity survey completed by Teledyne Geotech, and an archeological survey of the site completed by Texas A&M University, have been previously reported and will not be repeated here. The initial report on environmental baseline monitoring at the test well contained descriptions of baseline air and water quality, a noise survey, an inventory of microseismic activity, and a discussion of the installation of a liquid tiltmeter (Gustavson, 1979). The second report continued the description of baseline air and water quality of the test well site, included an inventory of microseismic activity during 1979 with interpretations of the origin of the events, and discussed the installation and monitoring of a liquid tiltmeter at the test well site. Also, a brief description of flooding at the test site was presented. The following report continues the description of baseline air and water quality of the test well site, includes a summary of microseismic activity before and during 1980, and describes the monitoring of a liquid tiltmeter at the test well site (Gustavson and others, 1980).

On the basis of analyses of geopressured geothermal resources by Bebout and others (1975a, b; 1976; 1978), a series of geothermal fairways were recognized within the Frio Formation along the Texas Gulf Coast. From the group of Frio Formation fairways, the Brazoria County fairway was determined to be the most suitable for testing because the permeabilities of the reservoir rocks containing the resource were higher here than the reservoir-rock permeabilities in all

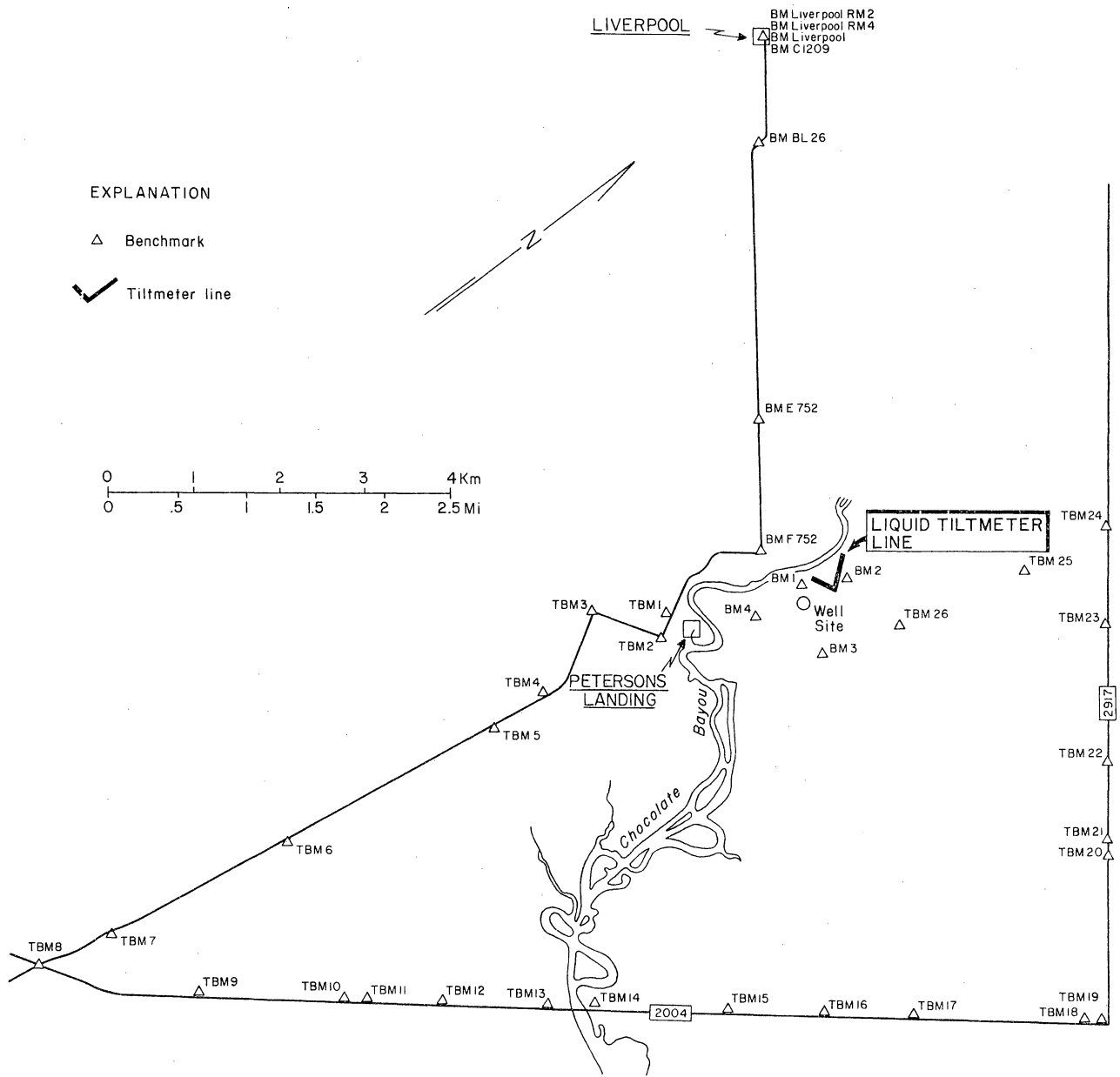

Figure 1. Location of Department of Energy-General Crude Oil Pleasant Bayou #1 and #2 geothermal test wells and environmental monitoring facilities. Both wells are located within well site.

other known geothermal fairways in the Texas Gulf Coast. On this basis, the Department of Energy-General Crude Oil Corporation Pleasant Bayou #1 well was spudded in July 1978.

Drilling of Pleasant Bayou #1 continued through the latter half of 1978 and into 1979. As this well neared total depth of approximately 17,000 ft (5,150 m), the drill string became stuck in the hole. This and additional mechanical problems required that the hole be plugged back to approximately 8,400 ft (2,500 m). Pleasant Bayou #1 was then converted into a disposal well.

After the completion of Pleasant Bayou #1 as a disposal well, the drilling rig was moved approximately 500 ft (150 m) to the north, and Pleasant Bayou #2 was drilled to a depth of nearly 16,500 ft (5,030 m). This well was completed in early November 1979 and flow tested. Initial formation fluid had a salinity of 131,000 ppm. The first injectivity tests using produced water indicated that disposal rates of 13,000 BWPD ($2,000 \text{ m}^3\text{d}^{-1}$) at 0 psi (0 kg cm^{-2}) and 35,000 BWPD ($5,600 \text{ m}^3\text{d}^{-1}$) at 700 psi (50 kg cm^{-2}) could be expected. Flow testing of the well continued through November and into December 1979. Flow testing was again resumed in September 1980 and continued through October.

Concurrent with early geopressured geothermal resource analysis was a series of environmental studies to determine both the major environmental concerns and the areas along the Texas coast that were most likely to be affected by geopressured geothermal energy development (Gustavson and Kreitler, 1976; Gustavson and others, 1978). Following the designation of the Brazoria County fairway as a test well site late in 1977, a detailed environmental analysis of the prospect area was initiated (White and others, 1978). The results of all environmental analyses to date are similar; induced surface subsidence and fault activation are the most serious potential environmental impacts, followed closely by potential impacts on air and water quality resulting from accidental releases of

geopressured geothermal fluids at the surface. Because of the proximity of the test well site to several homes along the Chocolate Bayou and to two large petrochemical plants that produce continuous background rumbles, noise was also considered to be an important environmental parameter at the Brazoria County test well site.

On the basis of the preceding environmental studies, a program to obtain environmental baseline data in the vicinity of the test well site was initiated in early 1978. Baseline studies evaluated microseismicity, subsidence, air and water quality, and noise. Microseismicity and subsidence will continue to be monitored throughout 1981.

BASIC OBJECTIVES OF BASELINE SUBSIDENCE STUDIES ARE TO DETERMINE, FIRST, IF NATURAL SUBSIDENCE IS OCCURRING NEAR PLEASANT BAYOU #1 AND #2 AND, SECOND, IF PRODUCTION OR DISPOSAL OF GEOTHERMAL FLUIDS HAS INDUCED SUBSIDENCE OR FAULTING.

Microseismic monitoring near Pleasant Bayou #1 and #2 indicates evidence of (1) naturally occurring seismic activity of local magnitudes exceeding 0.25 within 4 km of the test well site, and (2) seismic activity of local magnitudes, resulting from disposal of geothermal fluids or by other commercial waste fluid disposal operations in the area, exceeding 0.25 within 4 km of the test well site.

Testing of the energy resources stored in geopressed formations beneath the Texas Gulf Coast will require withdrawal of massive volumes of fluid at relatively high rates. Currently, production rates from a single test well may be as high as 30,000 bbl (4,800 m³) per day. Since recharge into the geopressed formations is expected to be negligible compared with the withdrawal, substantial pressure drops and subsequent reservoir compaction are anticipated. In particular, it is estimated that the reservoir compaction caused by one year's production from a single well could result in internal volumetric losses of approximately 10⁷ bbl (10⁶ m³). Volume changes of this magnitude, when concentrated in an area with maximum dimensions of only a few kilometers, will impose a significant additional load on the rocks surrounding the reservoir. On the basis of a disk approximation to the reservoir, the cumulative deviatoric component of this additional load will be about 100 bars within a few hundred meters of the reservoir and about 10 bars as far as 1.25 mi (2 km) away after one year's production from a single well. Deviatoric stress perturbations of this magnitude are sufficient to trigger substantial nonelastic deformation of the rocks surrounding the reservoir. This deformation may well be manifested

through multiple discrete slips on both pre-existing and newly created fracture planes, thus releasing part of the stored strain energy as seismic waves. Since the release of seismic energy can be a risk to the local environment, the possible correlation between the production of geopressured brines and the occurrence of microearthquakes deserves consideration. To correlate clearly geopressured brine production with the occurrence of seismic activity, a local seismic history should be obtained before the onset of the withdrawal of fluids.

Teledyne Geotech monitored seismic activity near the test well. The results of a previous reconnaissance survey in this region have been documented in an earlier publication (Teledyne Geotech, 1978).

This part of the report summarizes the principal results obtained before November 1, 1980, from the operation of a semipermanent microseismic monitoring network installed near the test well site (Teledyne Geotech, 1980).

The initial operating system included five surface instruments. Beginning in September 1979, four of these instruments were replaced by downhole instruments in 100-ft-deep (30-m) boreholes. The background noise spectra for the surface and downhole seismometers are compared in figure 2. The downhole sensors provide a noise reduction factor of 10 in power and about 3 in amplitude, thus lowering the detection threshold by one-half magnitude. Events with magnitude of -0.5 have been detected with the current array.

SUMMARY OF SEISMICITY BEFORE NOVEMBER 1, 1980

Since monitoring began at the Brazoria County site, a total of 3,902 seismic events have been observed and logged, of which 336 have been located (Appendix II). The activity by month is listed in table 1. Most events fall into a class with the following general characteristics:

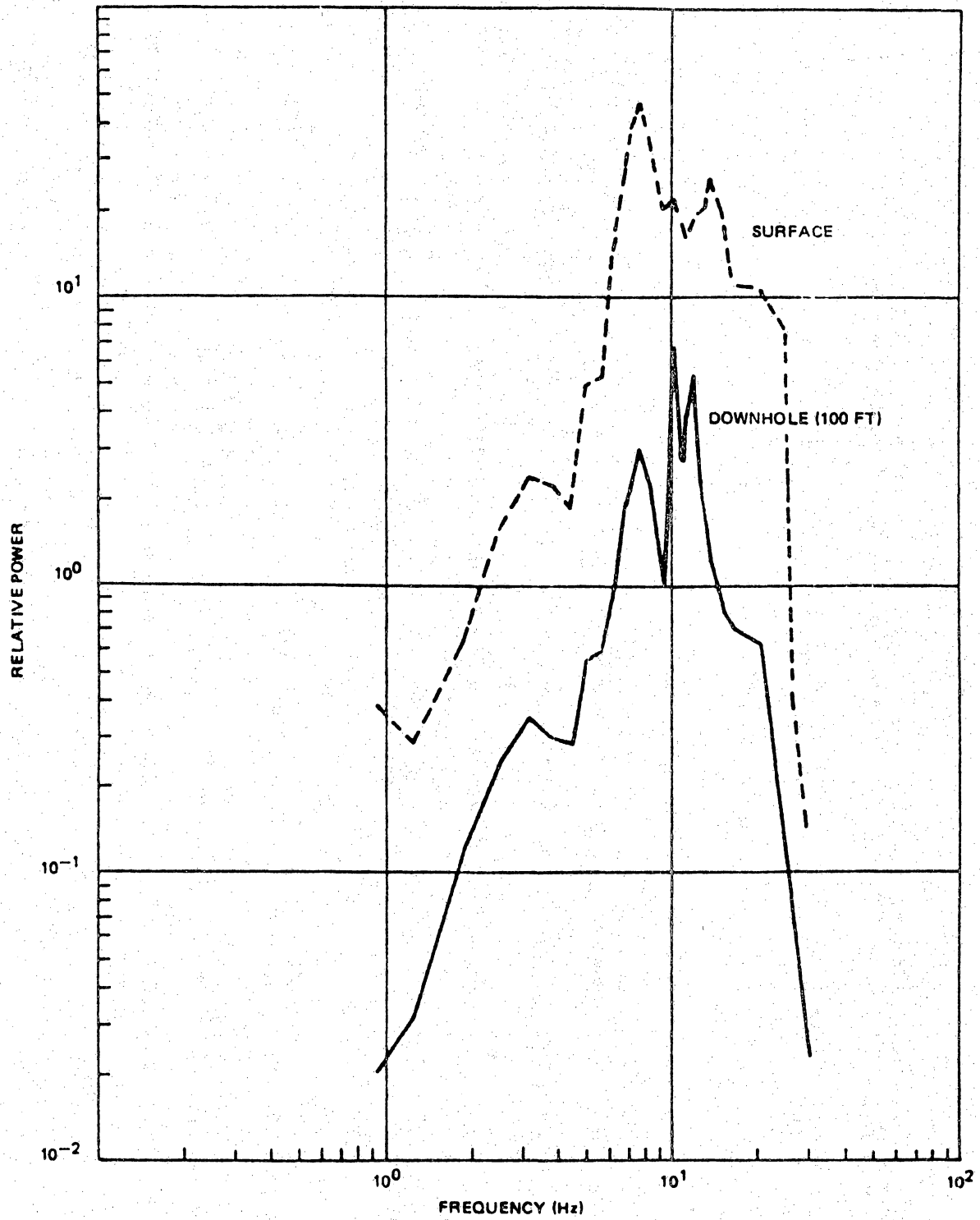

Figure 2. Spectral comparison of a background noise sample.

Table 1. Seismicity by month.

	Total events	Total located events	Natural events	Natural located events
1978 Sept.	40	0	-	-
Oct.	53	0	6	0
Nov.	259	78	10	8
Dec.	74	0	1	0
1979 Jan.	14	2	-	-
Feb.	0	0	-	-
Mar.	90	25	-	-
Apr.	180	39	-	-
May	200	0	-	-
Jun.	40	0	-	-
Jul.	System down	-	-	-
Aug.	System down	-	-	-
Sept.	101	0	-	-
Oct.	100	2	2	2
Nov.	177	46	78	38
Dec.	46	10	4	4
1980 Jan.	452	23	109	19
Feb.	692	15	43	10
Mar. (Mar. 19 to Apr. 13)	55	6	6	5
Apr. (system down)	2	2	1	1
May	153	15	103	14
Jun.	26	11	24	10
Jul.	15	6	1	1
Aug.	268	21	12	4
Sept.	228	9	21	9
Oct.	<u>637</u>	<u>26</u>	<u>22</u>	<u>7</u>
	3902	336	443	132

- a. times of origin in daylight hours only;
- b. impulsive first motions;
- c. frequencies of from 8 to 12 Hz;
- d. time delays across the array of up to 6 seconds;
- e. local magnitudes of 0.9 ± 0.2 ; and
- f. durations of 3 to 4 seconds.

Epicenters for 150 events of this type were located and plotted in figure 3. They are evidently explosive shots for seismic surveys running perpendicular and parallel to the regional geologic structure. A record of this type of event is shown in figure 4.

During November 1979 and continuing throughout 1980, well-defined events were recorded that differed sharply from the usual seismic shots in each of the above characteristics. This second class of events have

- a. times of origin at all hours;
- b. emergent first motions;
- c. frequencies of from 4 to 8 Hz;
- d. time delays across the array of up to 14 seconds;
- e. local magnitudes of 0.5 ± 0.5 ; and
- f. durations of 4 to 30 seconds.

An example of this type is in figure 5 and can be contrasted with the shot record in figure 4.

These arrivals were noteworthy because they appeared to consist primarily of surface waves with weak to undiscernible P and S waves. Recorded on vertical seismometers, these waves have arrival times that vary by up to 14 seconds across the 4.5-km array. Many traces have two or more readily apparent phases. Thus, these arrivals are assumed to be fundamental and higher mode Rayleigh waves with velocities in the range of 1,000 to 1,150 ft S⁻¹ (300 to 350 m S⁻¹).

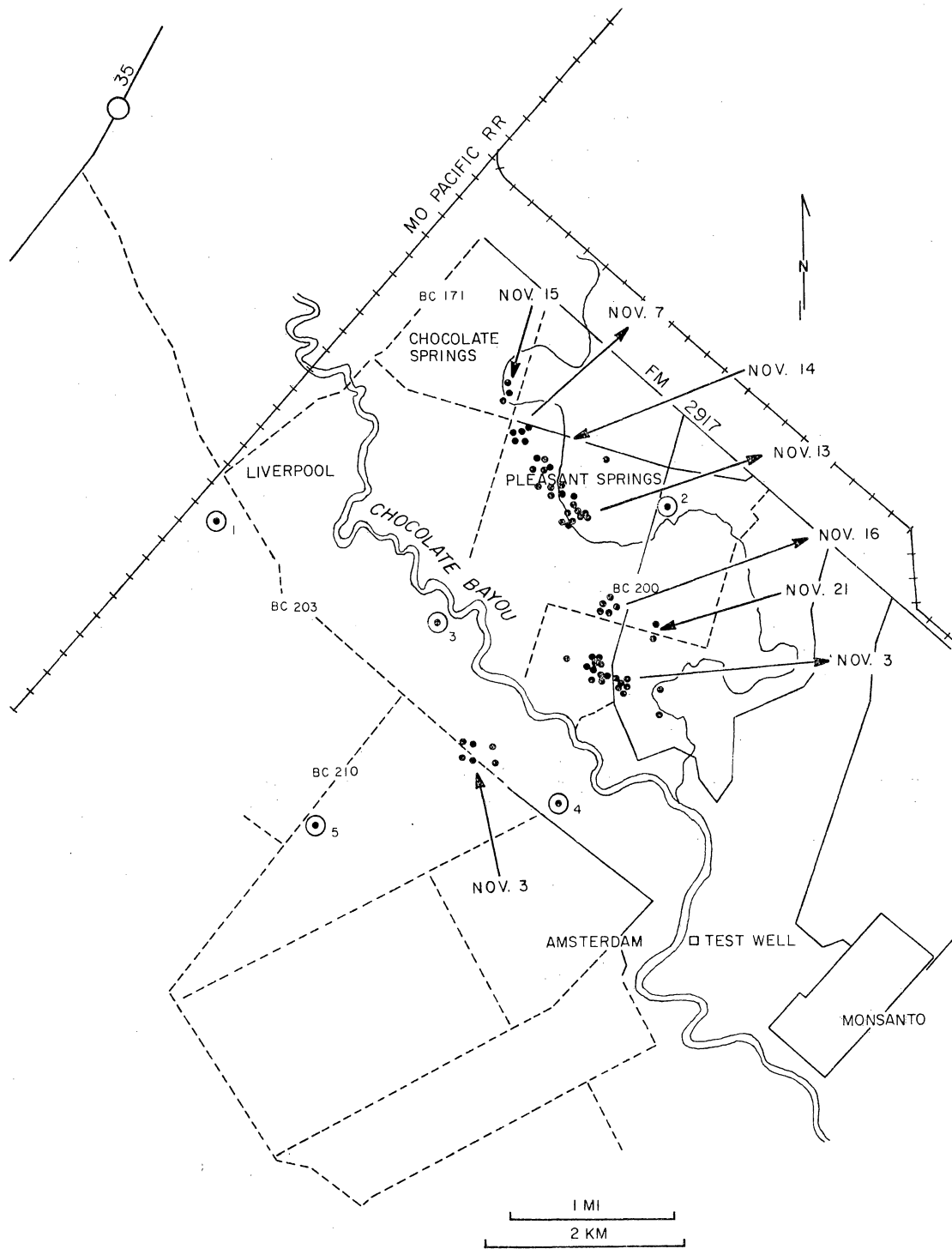

Figure 3. Epicenter locations of seismic shot activity; groups of events occurred between November 3 and November 16. Seismic recording stations are numbered 1-5.

16 27

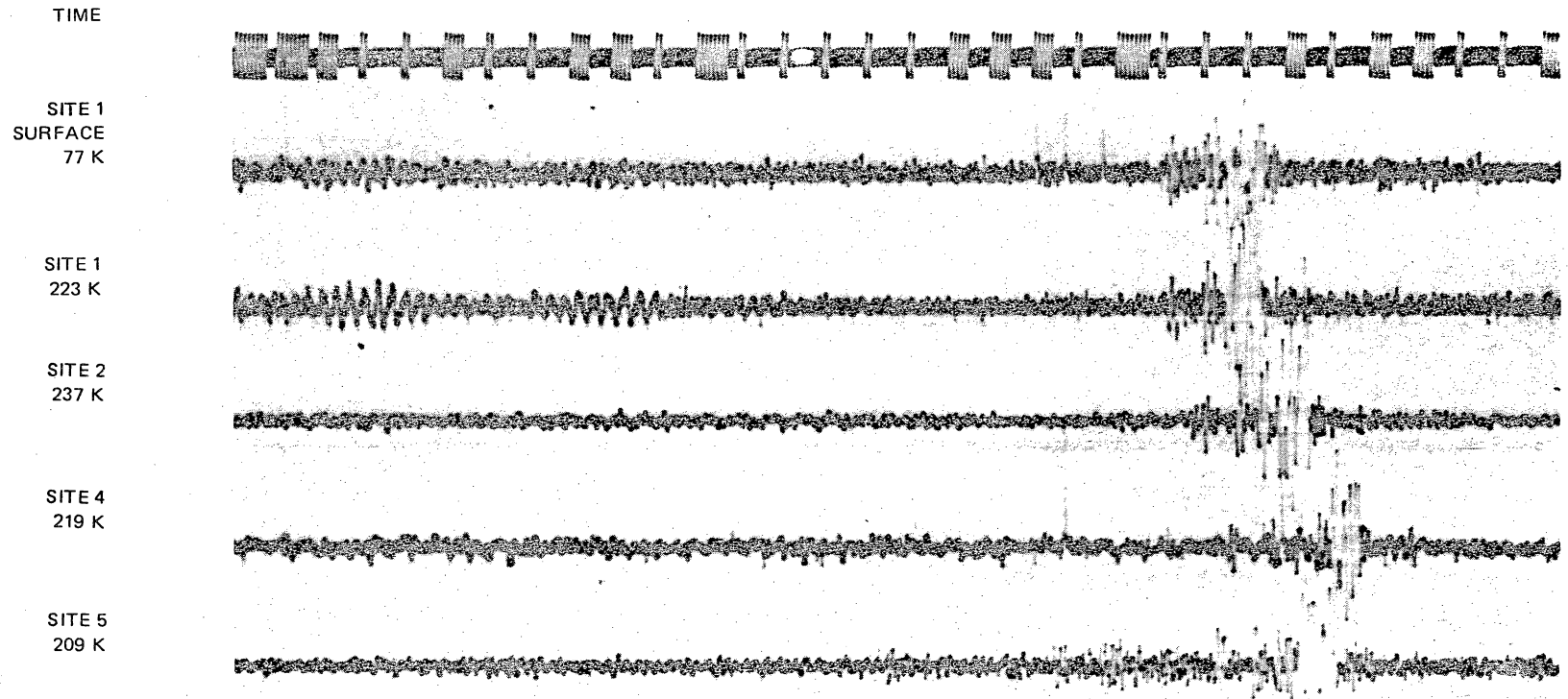

Figure 4. Typical seismic shot event, November 3, 1979.

G 11148

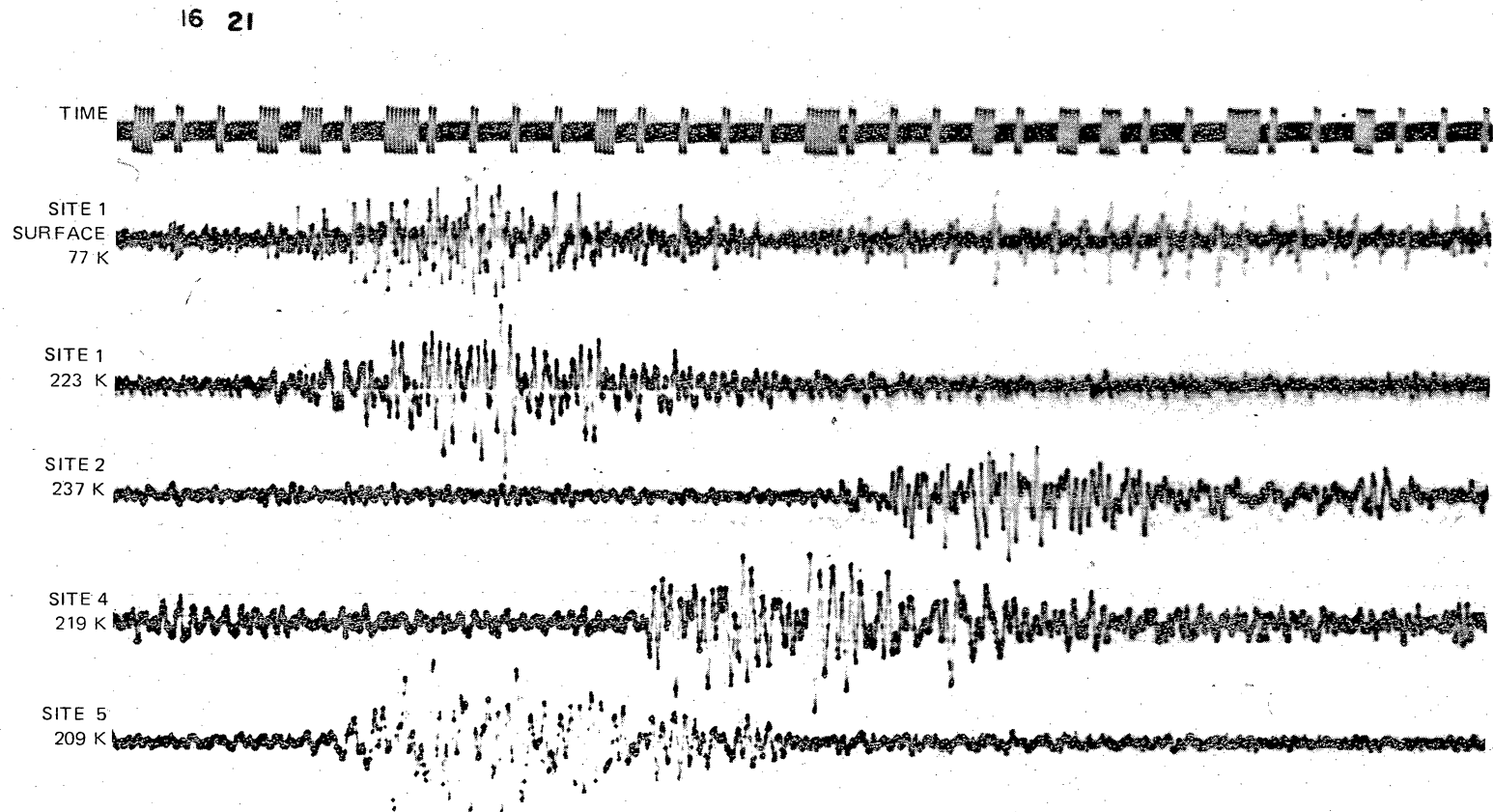

Figure 5. Typical surface wave event, November 4, 1979.

The absence of observable P waves and the presence of multiple modes in the surface wave train make arrival-time selection difficult. For each event, the arrival time of the phase that was most consistently observable across the four channels was selected for location purposes. Often this was the first arriving Rayleigh mode, but if the last (fundamental) mode had greater amplitude, it was used instead. A model velocity of 1,085 ft S⁻¹ (330 m S⁻¹) was used for all events, and the depth was arbitrarily constrained to 3.3 ft (1 m). Magnitudes were calculated using a body wave formula and are thus relative values only.

A third class of events was identified on January 20, 1980. These events were characterized by velocities as slow as the surface wave events but with very impulsive starts similar to seismic shots. More than 600 such events occurred over short time periods at 10:45 p.m., February 5, and at 12:30 a.m., February 12. Figure 6 is a sample of this "impulsive event" type. The consistency of the waveform seems to imply either fracturing from a fluid injection well or some type of machinery noise. Source directions were located toward the petrochemical plants, but no unusual activity was reported.

We recognized that some of the events classified as natural could be the result of thunder. Some of the natural events possess an identifiable spike on all channels preceding the acoustic velocity signal, indicating lightning followed by thunder. Radar summaries from the National Weather Service indicate strong, widespread storms during the recording of some but not all of these events. However, the spatial distribution of natural events does suggest significant evidence of movement along faults as sources of some of the activity. Further efforts are being made to resolve some of the ambiguity.

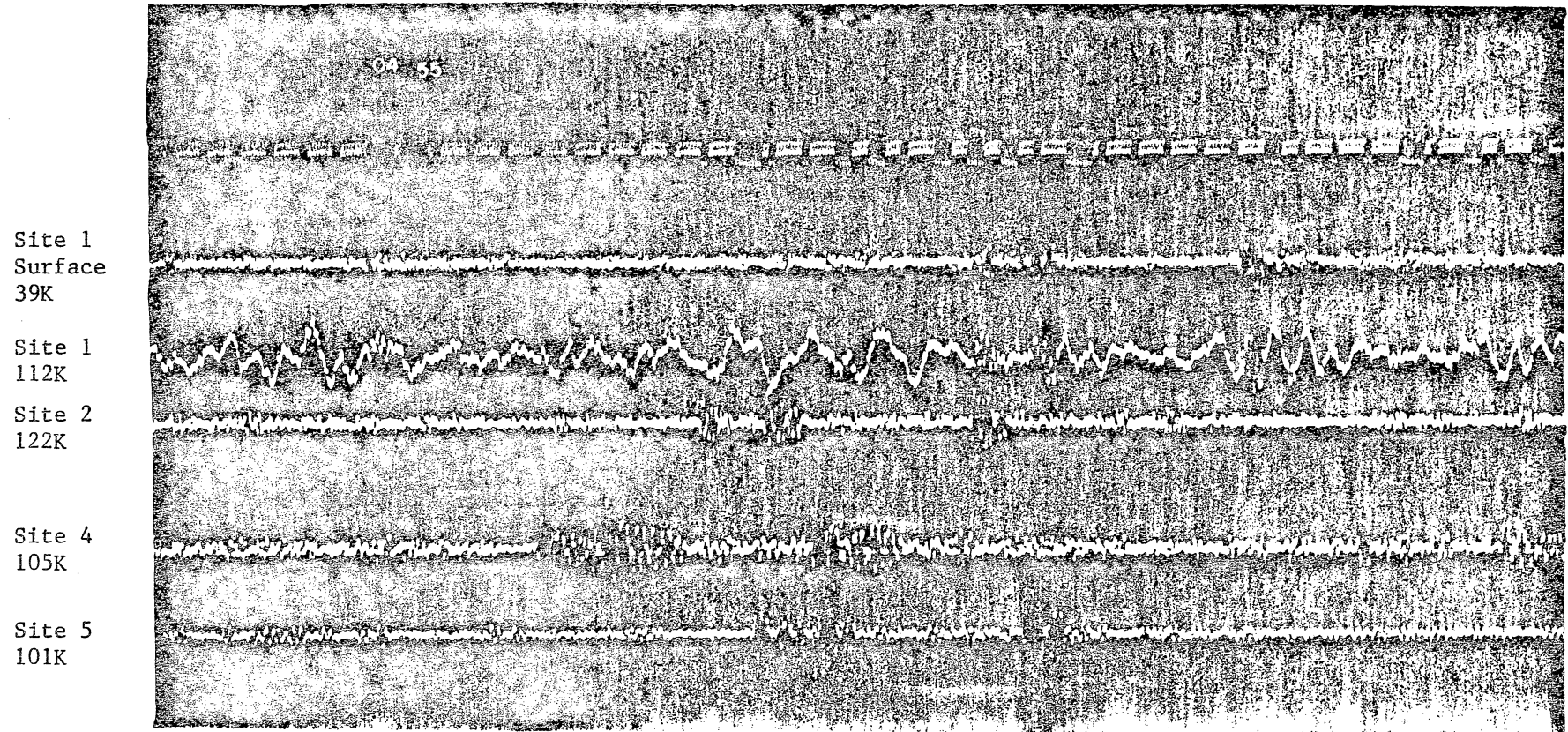

Figure 6. Typical surface wave event, February 5 and 6, 1980.

Many of the microseismic events of the type recorded in figure 6 appear to be associated with major growth fault systems. The structure map was developed on a stratigraphic surface with depth varying from 12,000 to 15,000 ft (3,640 to 4,545 m) below sea level. All the faults are normal faults that probably dip from 45° to 60° along a curving zone that steepens toward the surface. The epicenters of the microseismic events appear to have occurred preferentially toward the upthrown sides of several faults. If the events actually occurred within the fault zone, then they occurred at depths intermediate between the surface and 12,000 ft (3,640 m). Figures 7 and 8 show these microseismic events on structure maps at various depths. A decreasing correlation between natural events and known subsurface faults seems to exist at these shallower structural horizons, indicating the improbability of any surface effects caused by microseismic activity. The estimated depth of the microseismic events, on the basis of the known position of subsurface faults, calculated epicenters, and the estimated dip of growth faults, probably ranges from 5,000 to 6,000 ft (1,530 to 1,830 m) below sea level.

The concentration of microseismic events near the test well, the similarity in predicted depth of microseismic events, and the known depth of disposal (6,460 to 6,518 ft [1,969 to 1,986 m] below sea level) suggest that the events may be related to fluid injection. The chronological relation further supports this interpretation since over 40,000 bbl (6,350 m³) of water were injected at approximately 6,500 ft (1,960 m) during the week preceding the swarm of events that occurred on November 21 and 22, 1979.

Production testing at Pleasant Bayou #2 was initiated November 15, 1979. Between November 15 and November 18, approximately 40,000 bbl (225,000 ft³ [6,400 m³]) of water were produced and injected through perforations between 6,460 and 6,518 ft (1,969 and 1,986 m) in the disposal well, Pleasant Bayou #1

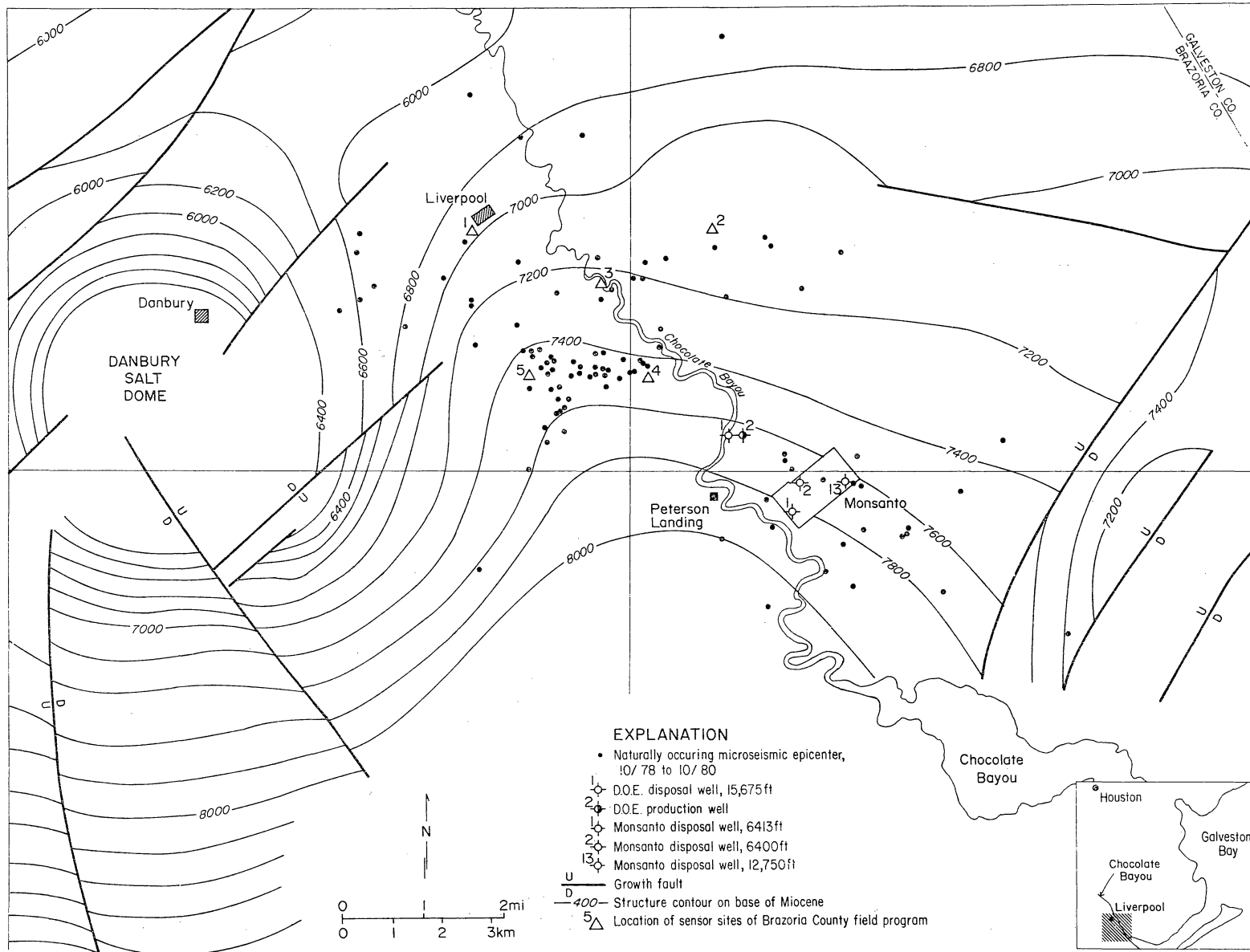

Figure 7. Structure contours on base of Miocene and cumulative epicenter map for natural events as of October 31, 1980.

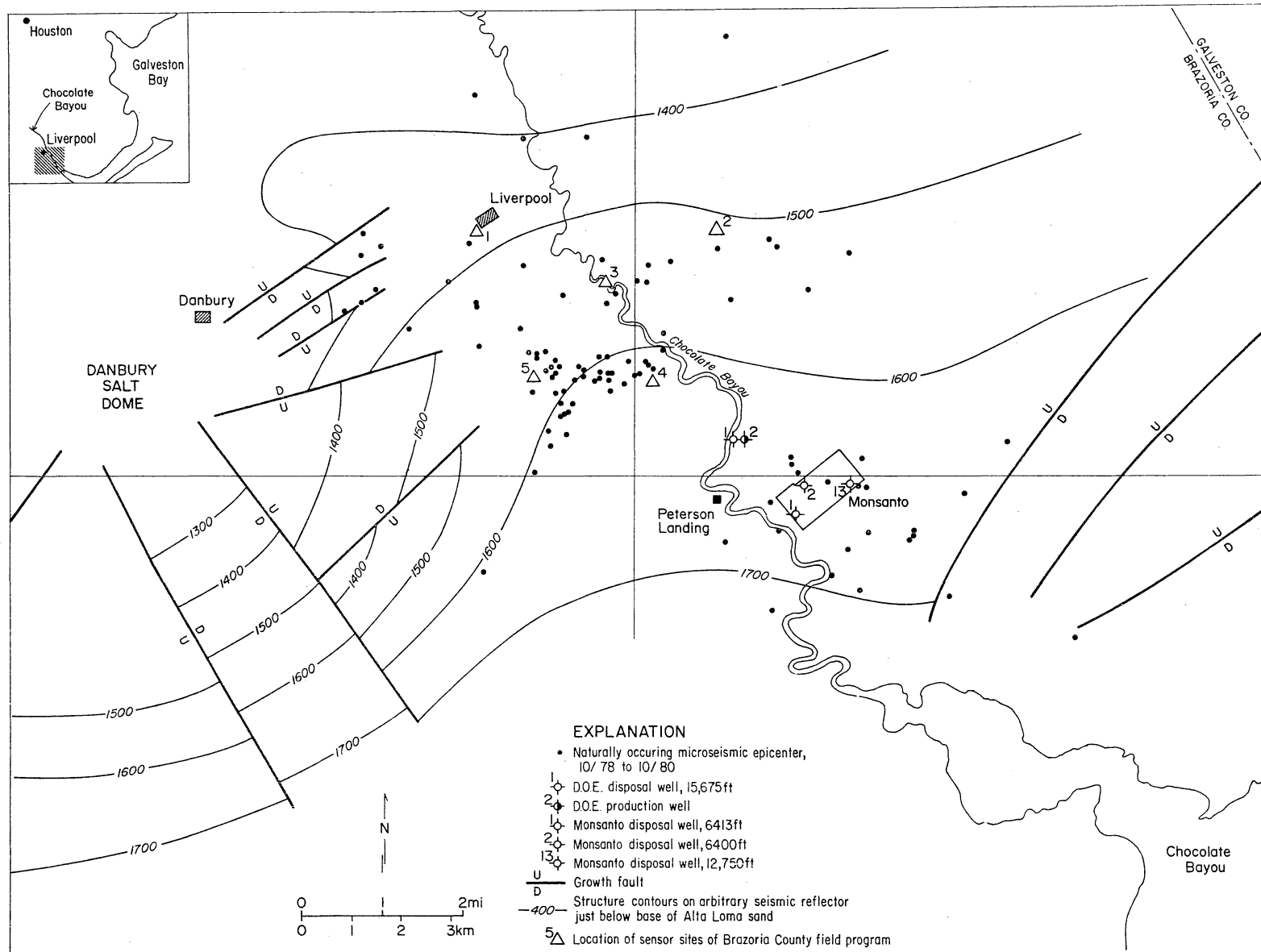

Figure 8. Structure contours on arbitrary seismic reflector just below base of Alta Loma sand and cumulative epicenter map for natural events as of October 31, 1980.

(table 2). Injection pump pressure data are not available for this interval but probably pressures were about 500 to 600 psi (35 to 42 kg cm⁻²). No fluids were produced between November 19 and November 22. Between November 23 and November 25, 46,839 bbls (7,435 m³) of water were produced and disposed of. Production testing ceased again on November 26. Testing was resumed on December 4 and continued at a rate of approximately 13,000 bbl (2,060 m³) of water per day until December 13 (table 2). Production during this interval was 155,483 bbls (24,680 m³) of water. Injection pressures steadily increased from 540 psi (38 kg cm²) on December 4 to 700 psi (50 kg cm²) when the well was shut on December 14, 1979. Production testing was resumed September 17, 1980, and was continuous through October 31. Injection pump pressure generally ran lower than the previous testing series, averaging 320 psi (23 kg cm²) from September 17 to October 7 and 540 psi (38 kg cm²) from October 8 to October 31. Fluid disposal during this 45-day interval was 557,378 bbls (88,472 m³).

During the 1979 testing, however, Monsanto Corporation disposed of approximately 30,000 to 40,000 bbls (4,762 to 6,350 m³) per day of fluid at average pump pressure of 500 to 1,200 psi (35 to 85 kg cm⁻²) in the interval of 3,000 to 6,400 ft (910 to 1,940 m). Monsanto disposal wells are located approximately 1.2 mi (2 km) east of Pleasant Bayou #2. These wells have operated almost continuously since 1965 and have disposed of 150,000,000 bbls (23,800,000 m³) of fluid. Observed microseismic events may also be related to injection of waste fluids into these wells.

Although the relation between high-volume fluid disposal and microseismicity/seismicity has been documented elsewhere by Raleigh and others (1972, 1976) and Healy and others (1968), the relation among microseismicity, fluid injection, and structure in the vicinity of Pleasant Bayou #1 and #2 is not clearly understood. Continued microseismic monitoring through 1981 may

Table 2. Disposal well, Pleasant Bayou.*

Date	Volume (barrels)	Injection Pressure (psi)	BHP† (psig)
11/16/79	12,721	~550	3,222.00
11/17/79	~16,000	~550	3,244.00
11/19/79	well shut in	~550	3,028.00
11/23/79	10,625	~550	3,028.00
11/24/79	15,853	~550	3,232.00
11/25/79	15,986	~550	3,258.00
12/4/79	5,505	540	3,177.17
12/5/79	3,266	605	3,219.18
12/6/79	13,580	630	3,233.02
12/7/79	13,712	640	3,249.15
12/8/79	13,694	650	3,253.12
12/9/79	13,831	660	3,264.02
12/10/79	13,670	680	3,275.65
12/11/79	13,647	680	3,285.29
12/12/79	13,602	700	3,294.29
12/13/79	13,569.6	700	3,294.92
12/14/79	well shut in	700	3,292.25
9/17/80	6,720	129	10,872.25
9/18/80	6,124	153	10,865.72
9/19/80	6,624	153	10,855.25
9/20/80	6,624	165	10,855.25
9/21/80	6,624	179	10,250.33
9/22/80	10,848	223	10,635.61
9/23/80	10,944	253	10,625.39
9/24/80	10,944	269	10,616.72
9/25/80	10,894	280	10,611.44
9/26/80	10,896	290	10,607.05
9/27/80	10,896	300	10,603.54
9/28/80	10,896	310	10,600.10
9/29/80	10,896	317	10,597.16
9/30/80	10,896	318	10,594.08
10/1/80	10,848	326	10,591.43
10/2/80	10,896	480	10,134.05

Table 2 (cont.)

Date	Volume (barrels)	Injection Pressure (psi)	BHP† (psig)
10/3/80	19,200	495	10,122.20
10/4/80	19,200	501	10,116.54
10/5/80	14,976	519	10,325.51
10/6/80	15,648	402	---
10/7/80	15,840	484	10,428.10
10/8/80	15,300	482	10,426.94
10/9/80	14,100	483	10,427.87
10/10/80	13,152	479	10,425.19
10/11/80	13,152	496	10,423.83
10/12/80	13,200	503	10,460.67
10/13/80	13,248	518	10,418.77
10/14/80	13,248	484	10,415.97
10/15/80	13,248	525	10,415.45
10/16/80	13,248	527	10,413.62
10/17/80	13,344	532	10,411.71
10/18/80	13,248	541	10,409.42
10/19/80	13,344	547	10,408.26
10/20/80	13,440	551	10,406.90
10/21/80	13,440	559	10,405.20
10/22/80	13,440	565	10,403.57
10/23/80	13,056	571	10,401.83
10/24/80	13,056	565	10,400.47
10/25/80	12,960	558	10,398.89
10/26/80	13,056	568	10,396.38
10/27/80	13,248	580	10,395.01
10/28/80	13,152	584	10,396.28
10/29/80	13,056	576	10,394.28
10/30/80	13,152	555	10,390.45
10/31/80	13,056	551	10,388.78

*Perforated interval, 6,460-6,518 ft below MSL

†Bottom hole pressure

provide additional data when flow testing of the well is resumed. It should be clearly understood that disposal of large volumes of fluid has been under way in the vicinity of the geopressed geothermal well since 1965 without recognizable impacts on the surface environment. Therefore, we assume that disposal of geothermal fluids at the test well site will probably not result in any recognizable surface impacts.

The multiliquid tiltmeter at the test well site was operated at irregular intervals, but gave no evidence of subsidence (fig. 9).

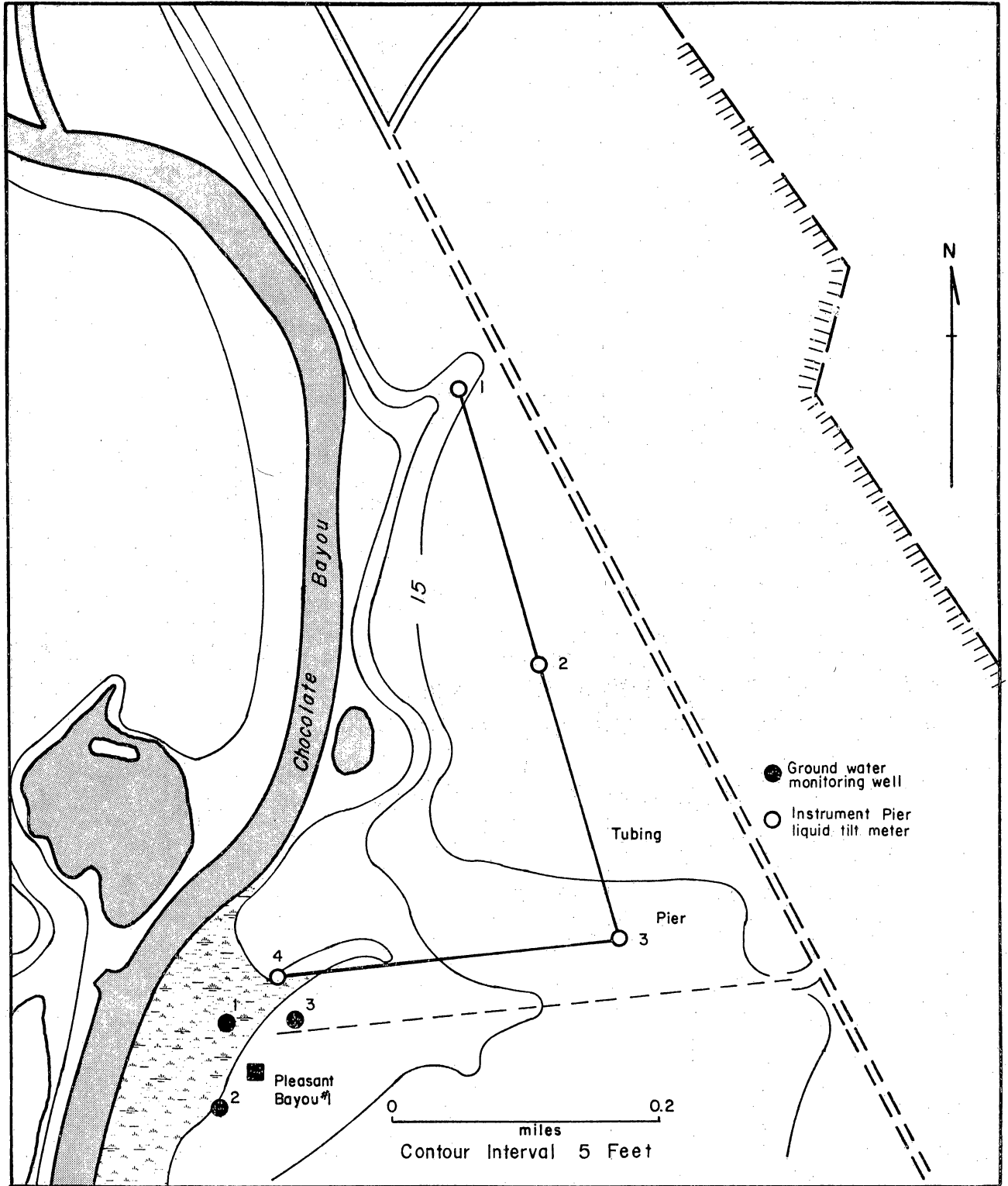

Figure 9. Location of ground-water monitoring wells and multiliquid tiltmeter line.

THE OBJECTIVE OF AIR QUALITY MONITORING IS TO DETERMINE BASELINE AIR QUALITY DATA AT THE SITE OF THE GEOPRESSURED GEOTHERMAL TEST WELL.

Air quality at Pleasant Bayou #1 and #2 test well site does not exceed national ambient air quality standards for particulates or sulfur oxide.

Four air quality parameters--particulates, sulfur dioxide, methane, and hydrogen sulfide--are being monitored at Pleasant Bayou #1 and #2 to determine local baseline air quality. National ambient air quality standards for particulates and sulfur oxides were not exceeded during 1980 (figs. 10 and 11). National standards are not available at this time for methane and hydrogen sulfide (figs. 12 and 13). Data summarized in figures 10 through 13 were collected by Radian Corporation approximately 0.5 mi (0.8 km) northwest of the test well site during 1980 (see Appendix I for data acquired and for descriptions of instrument systems and sampling program). In January 1979, an automated climate recording station was installed at the test well site to provide on-site wind direction and velocity data.

The data presented in figures 10 through 13 provide an adequate baseline assessment for air quality in the vicinity of the test well. Casual analysis of figures 11 through 14 suggests that major sources of air pollution lie to the northwest, north, east, and southeast, coinciding with the location of major petrochemical and industrial complexes in Houston, Galveston, and Texas City. Nearby petrochemical plants probably affect air quality at the test site when winds are from the southeast. Composition of emissions from petrochemical processing and waste disposal at local petrochemical plants is not known; therefore, the relation between observed air quality at the test well site and emissions from local petrochemical plants is not clear.

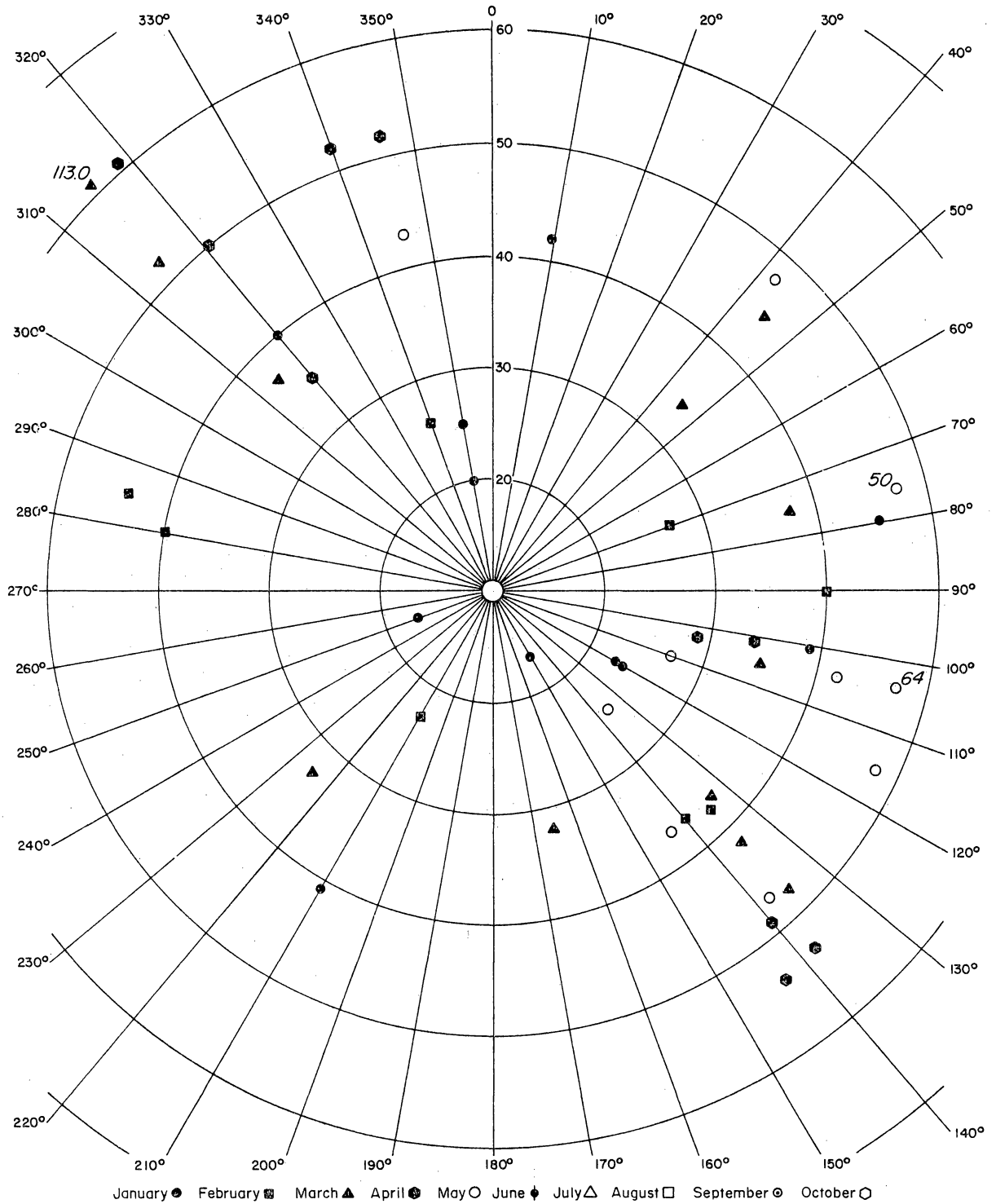

Figure 10a. Daily particulate concentration averages in micrograms per cubic meter for January through May.

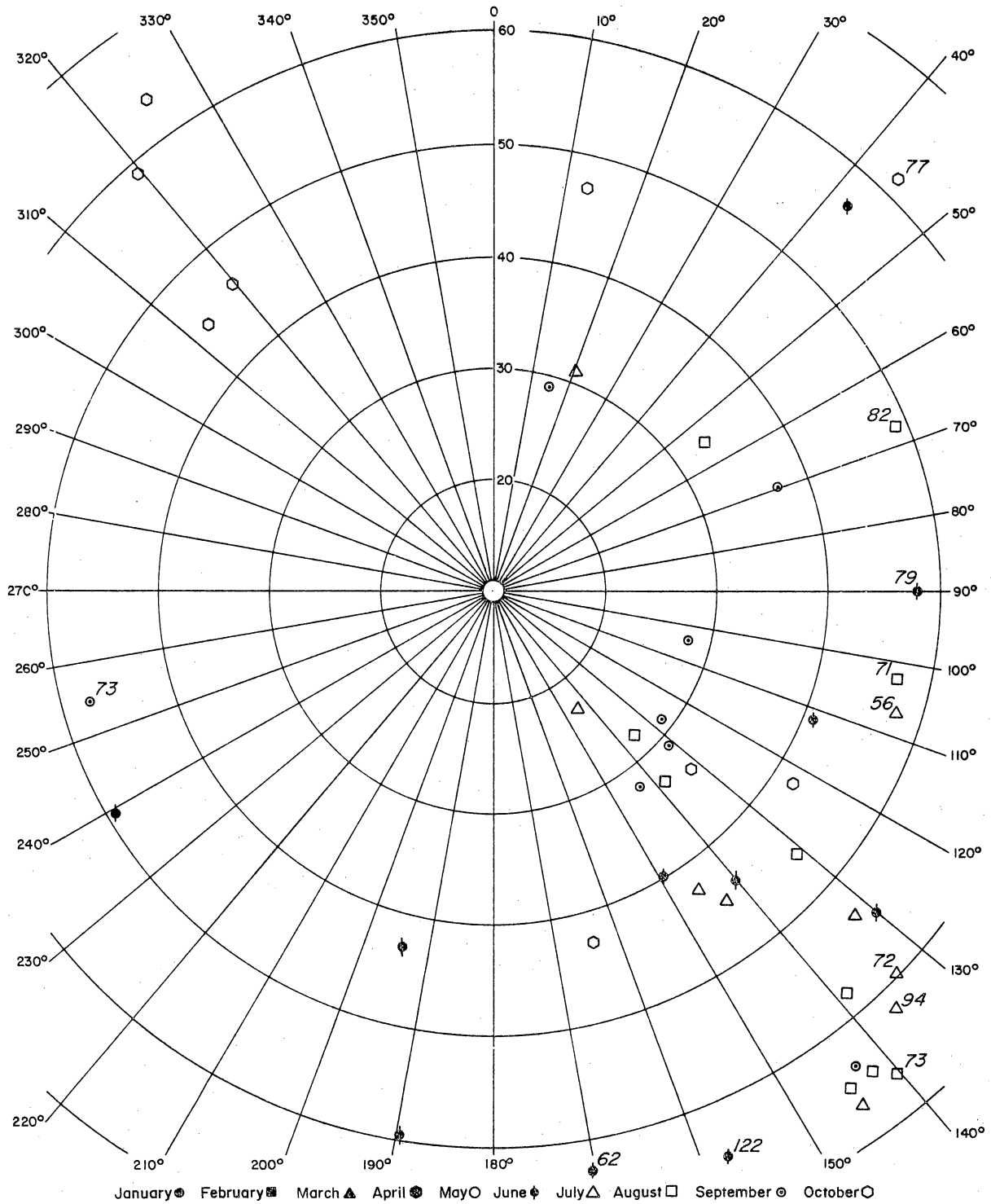

Figure 10b. Daily particulate concentration averages in micrograms per cubic meter for June through October.

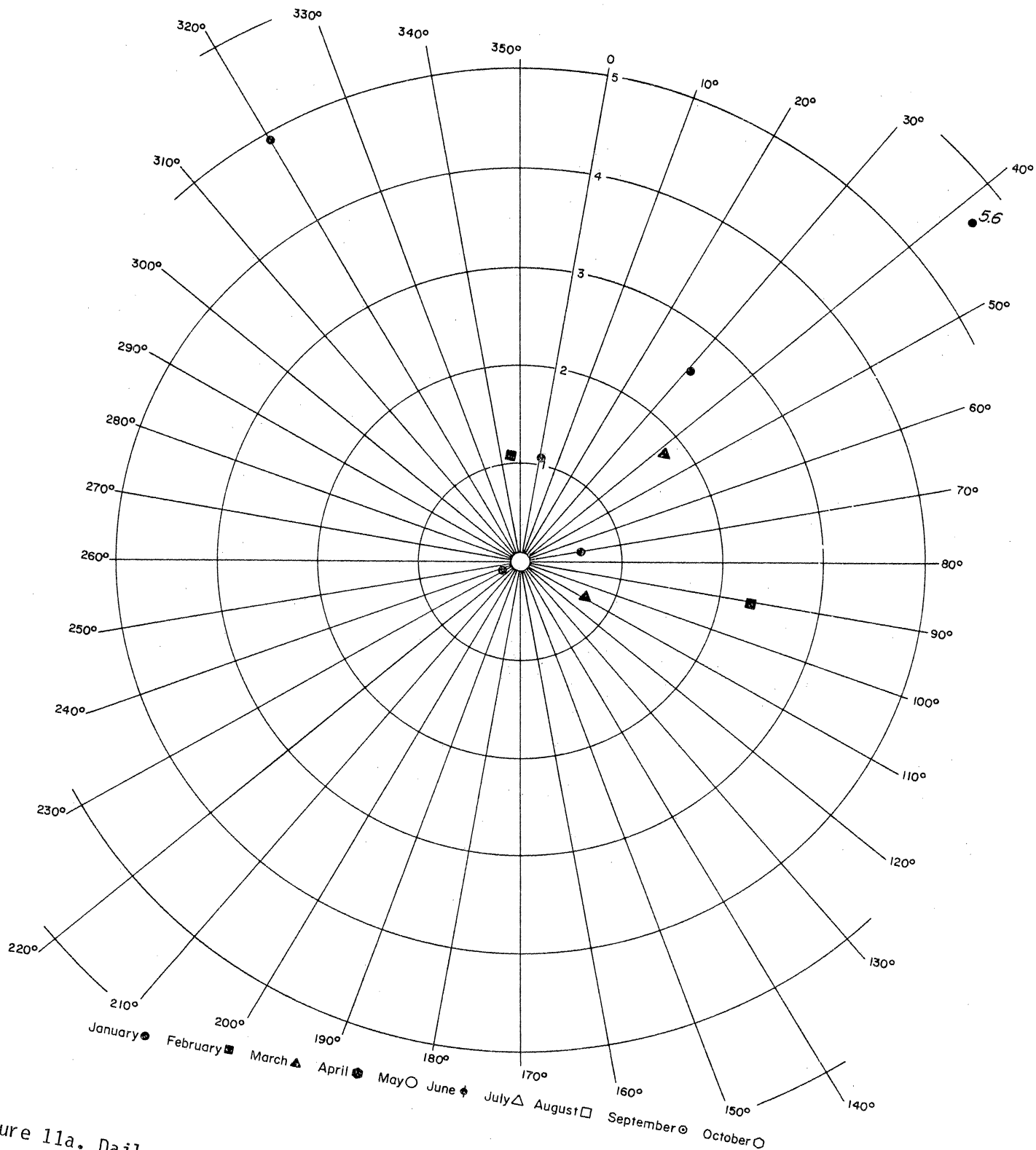

Figure 11a. Daily sulfur dioxide concentration averages in micrograms per cubic meter for January through May.

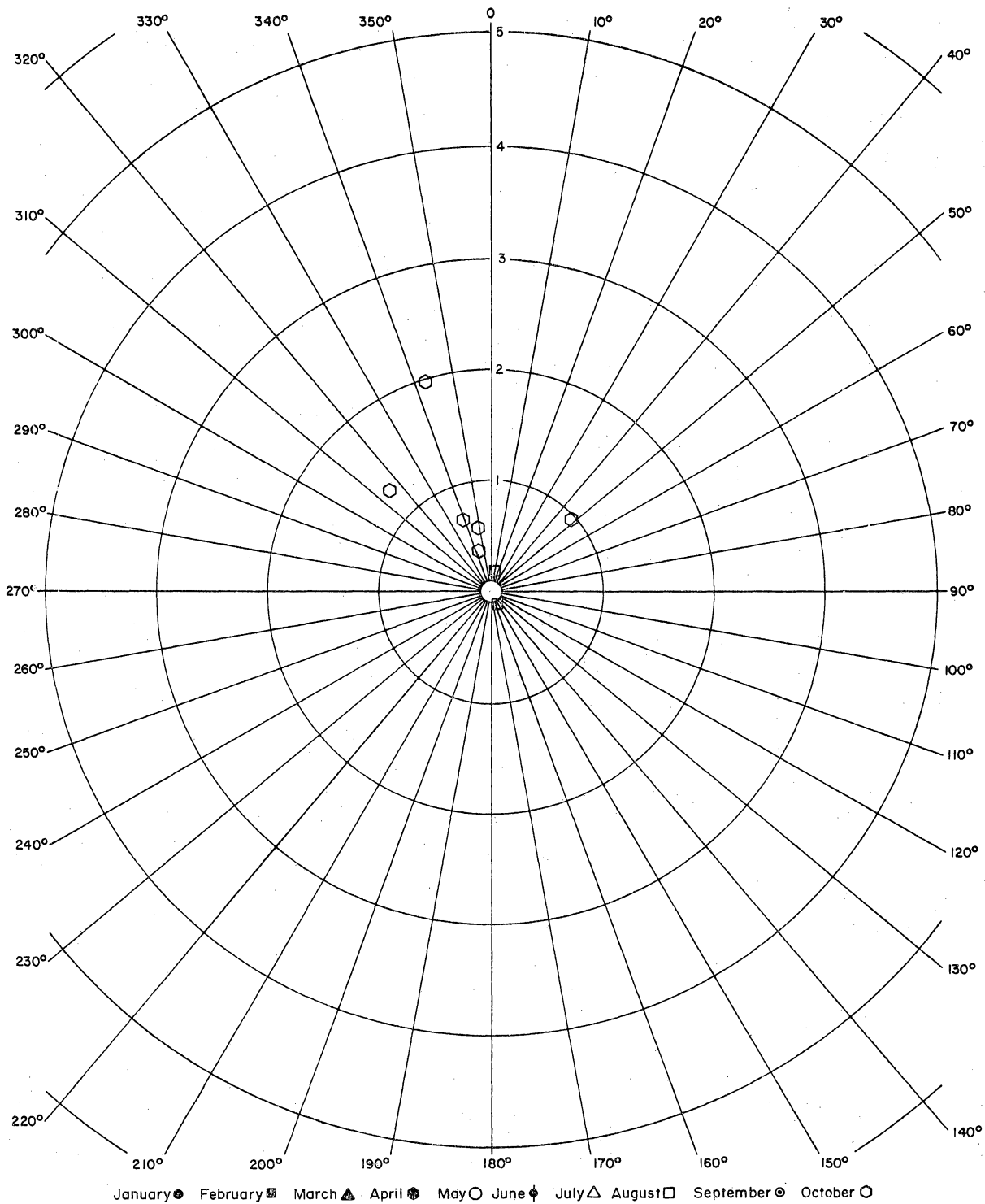

Figure 11b. Daily sulfur dioxide concentration averages in micrograms per cubic meter for June through October.

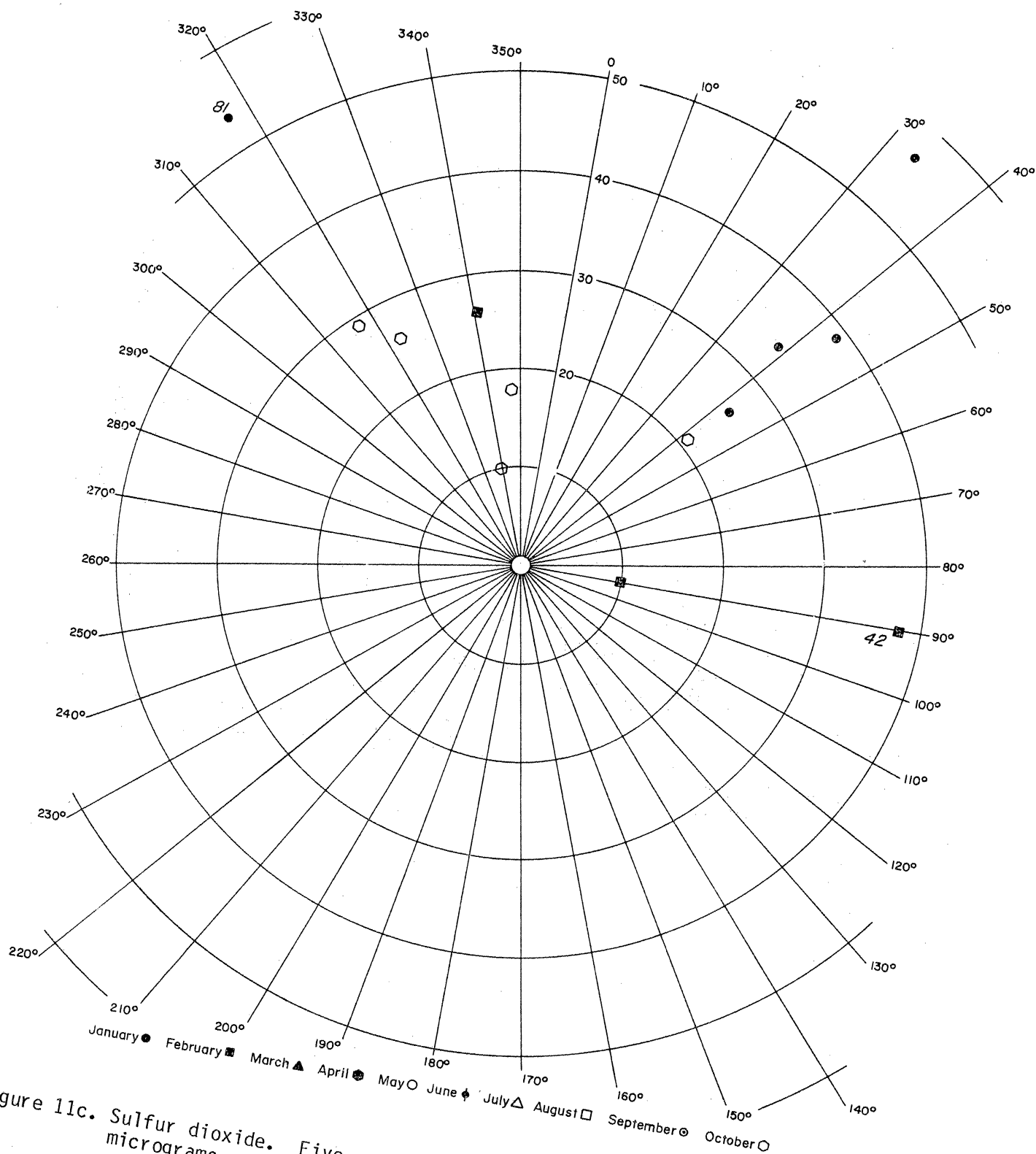

Figure 11c. Sulfur dioxide. Five maximum 1-hour sliding averages per month in micrograms per cubic meter for January through October.

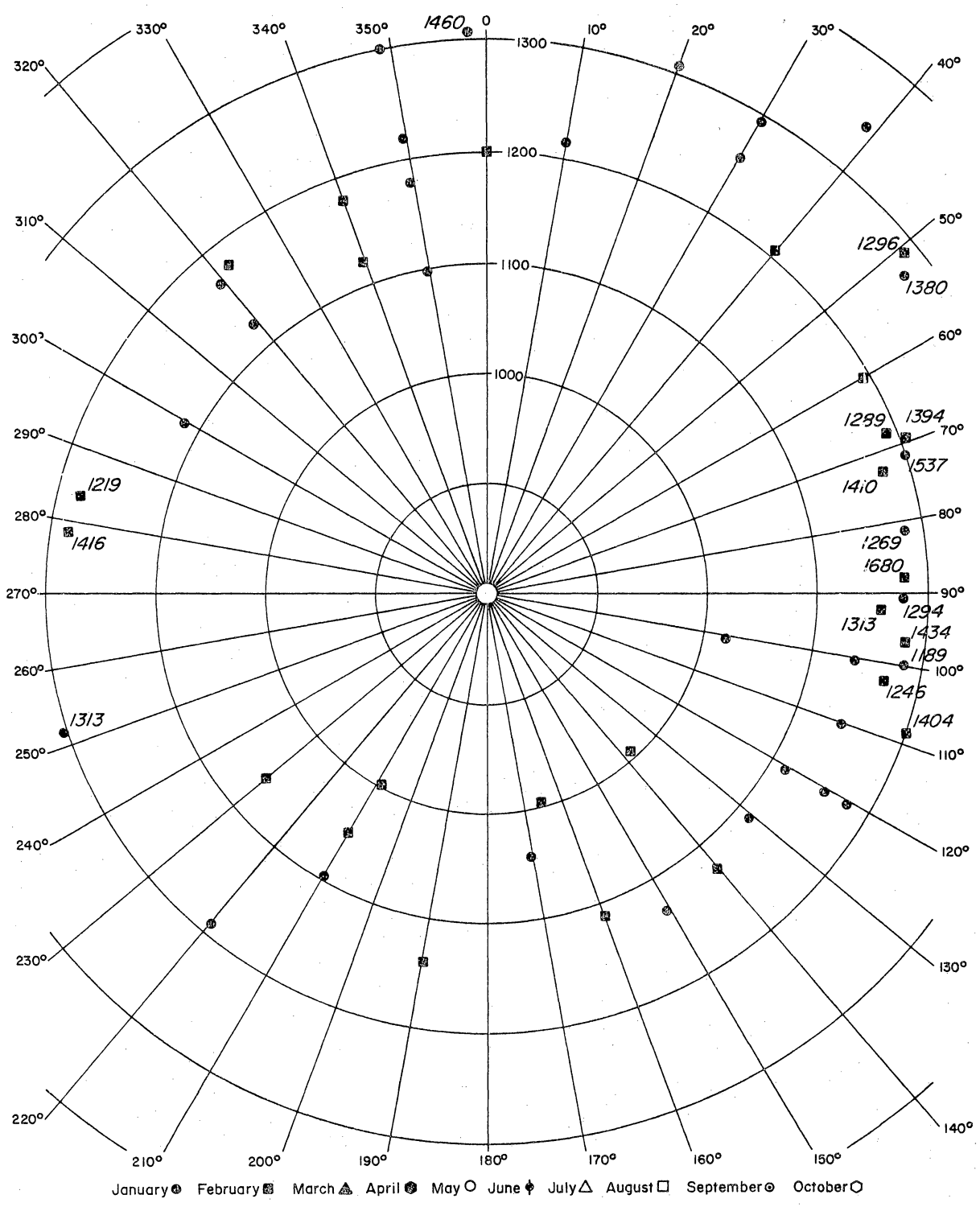

Figure 12a. Daily methane concentration averages in micrograms per cubic meter for January through February.

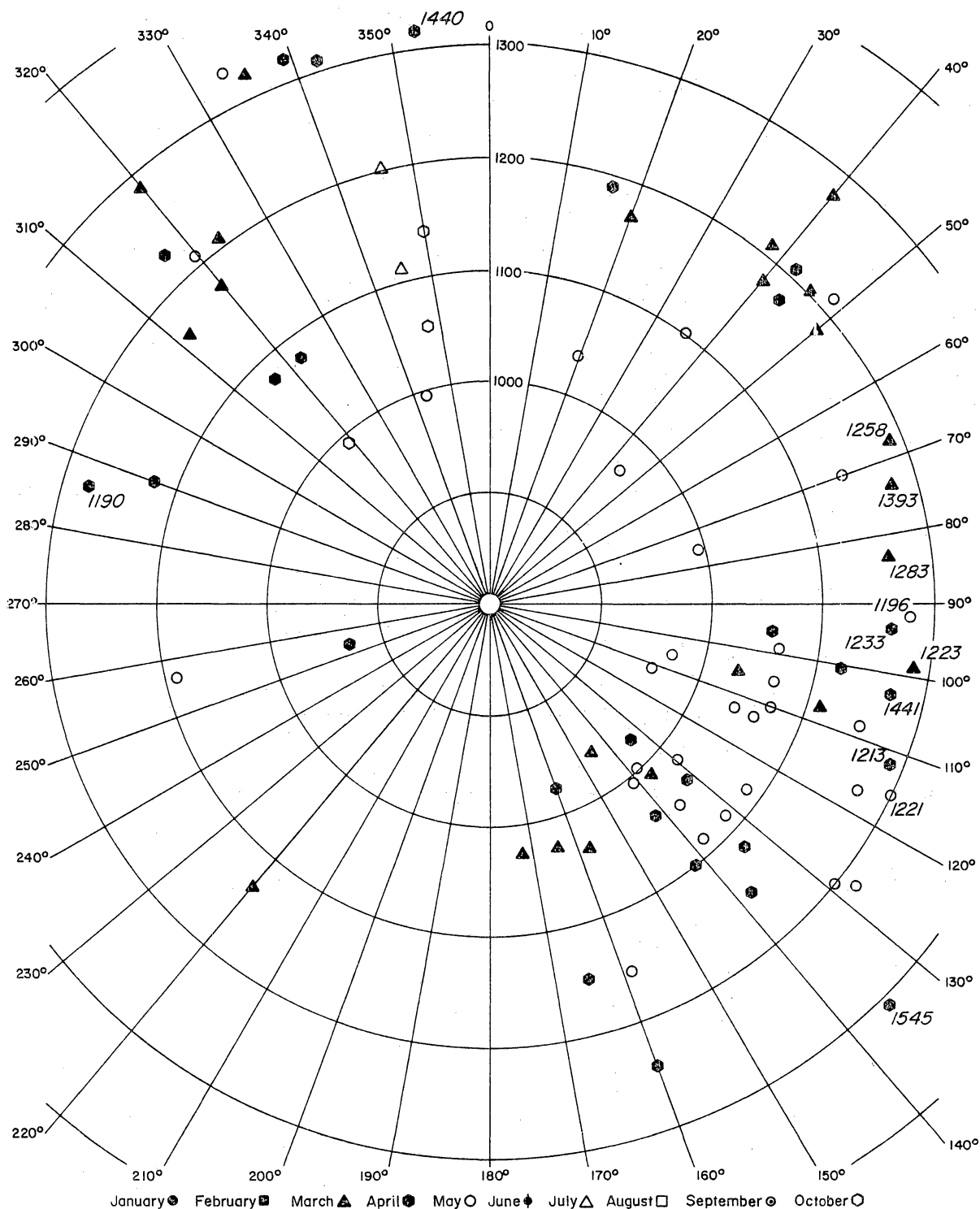

Figure 12b. Daily methane concentration averages in micrograms per cubic meter for March through May.

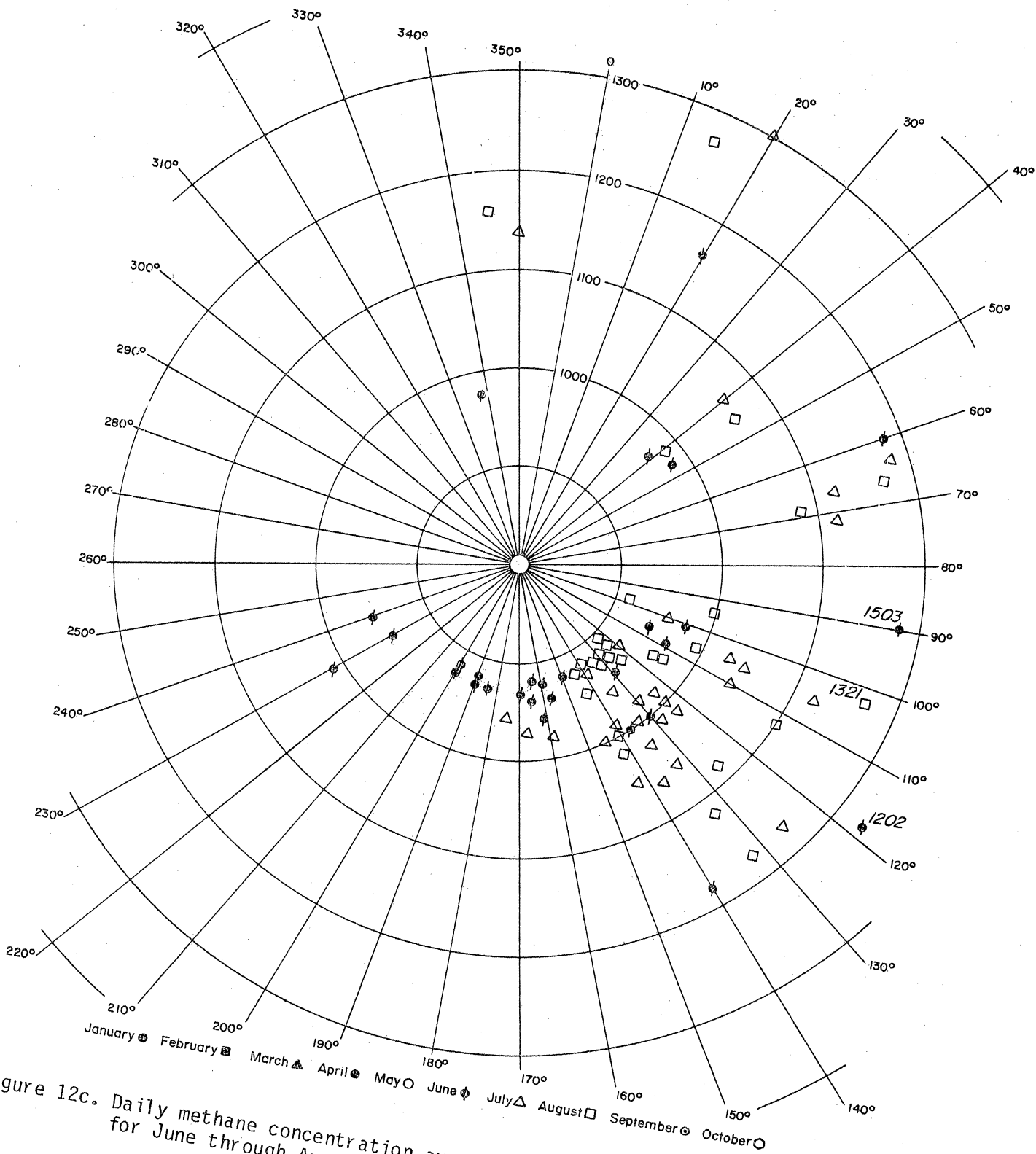

Figure 12c. Daily methane concentration averages in micrograms per cubic meter for June through August.

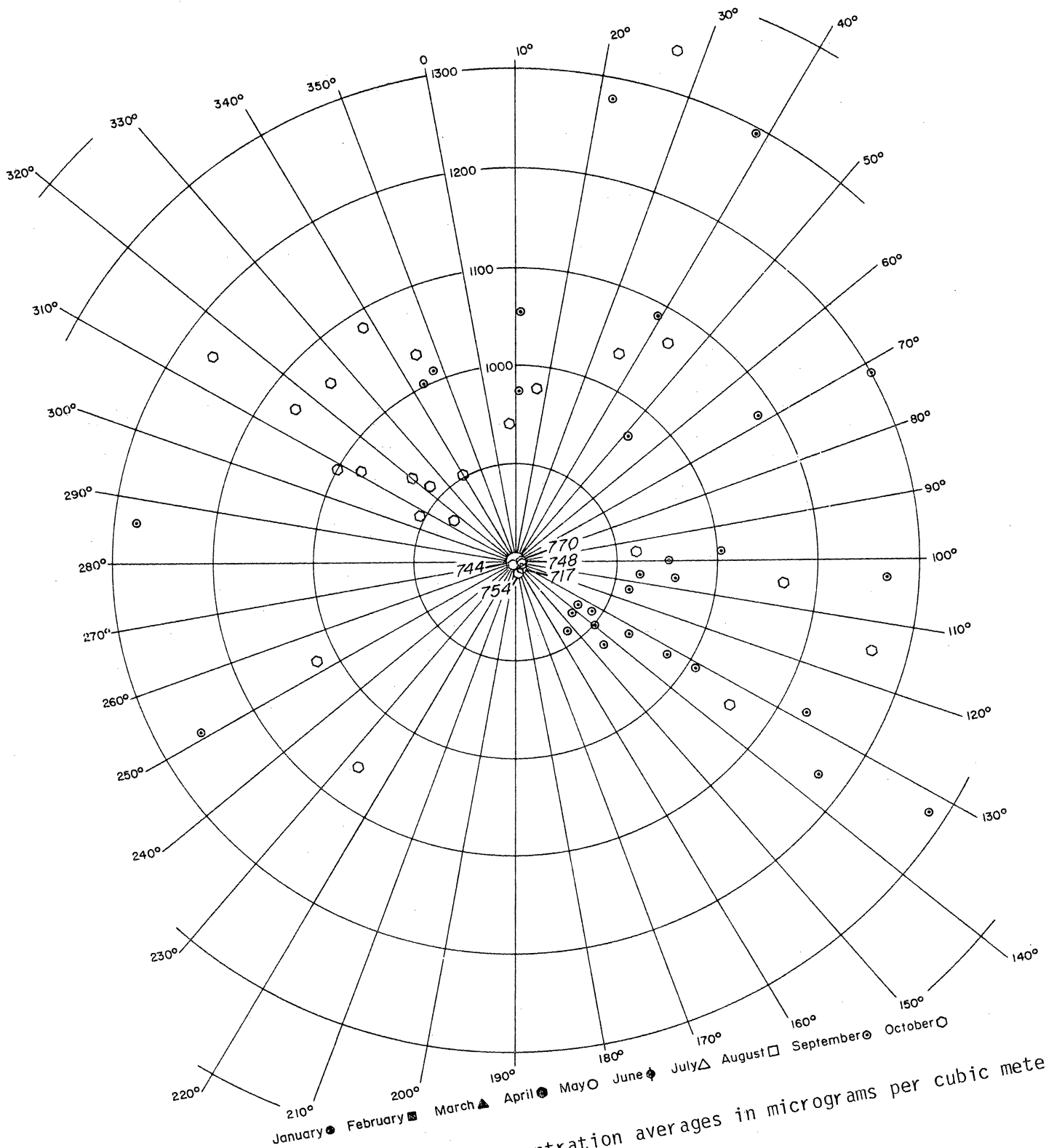

Figure 12d. Daily methane concentration averages in micrograms per cubic meter for September through October.

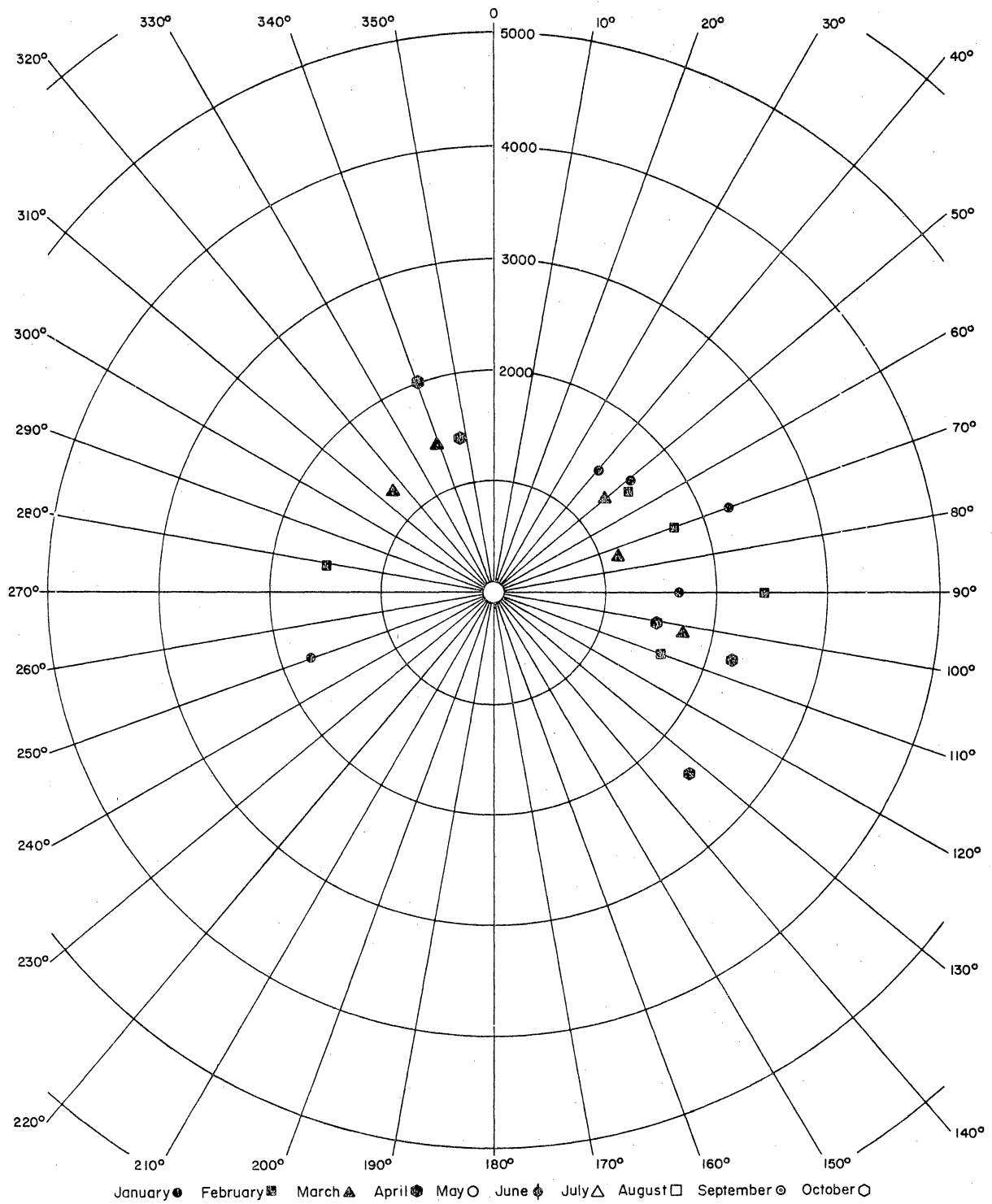

Figure 12e. Methane. Five maximum 3-hour sliding averages per month in micrograms per cubic meter for January through April.

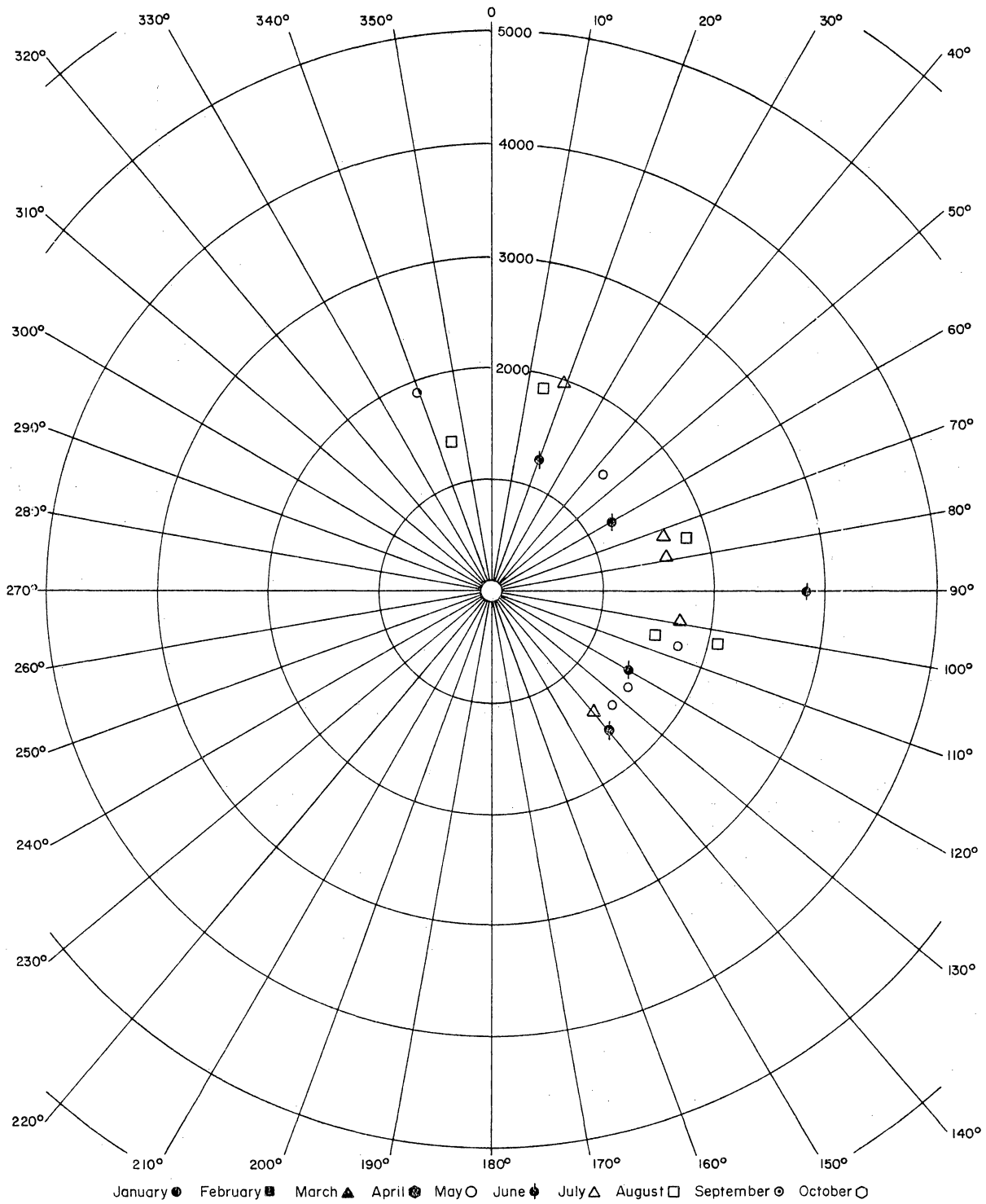

Figure 12f. Methane. Five maximum 3-hour sliding averages per month in micrograms per cubic meter for May through August.

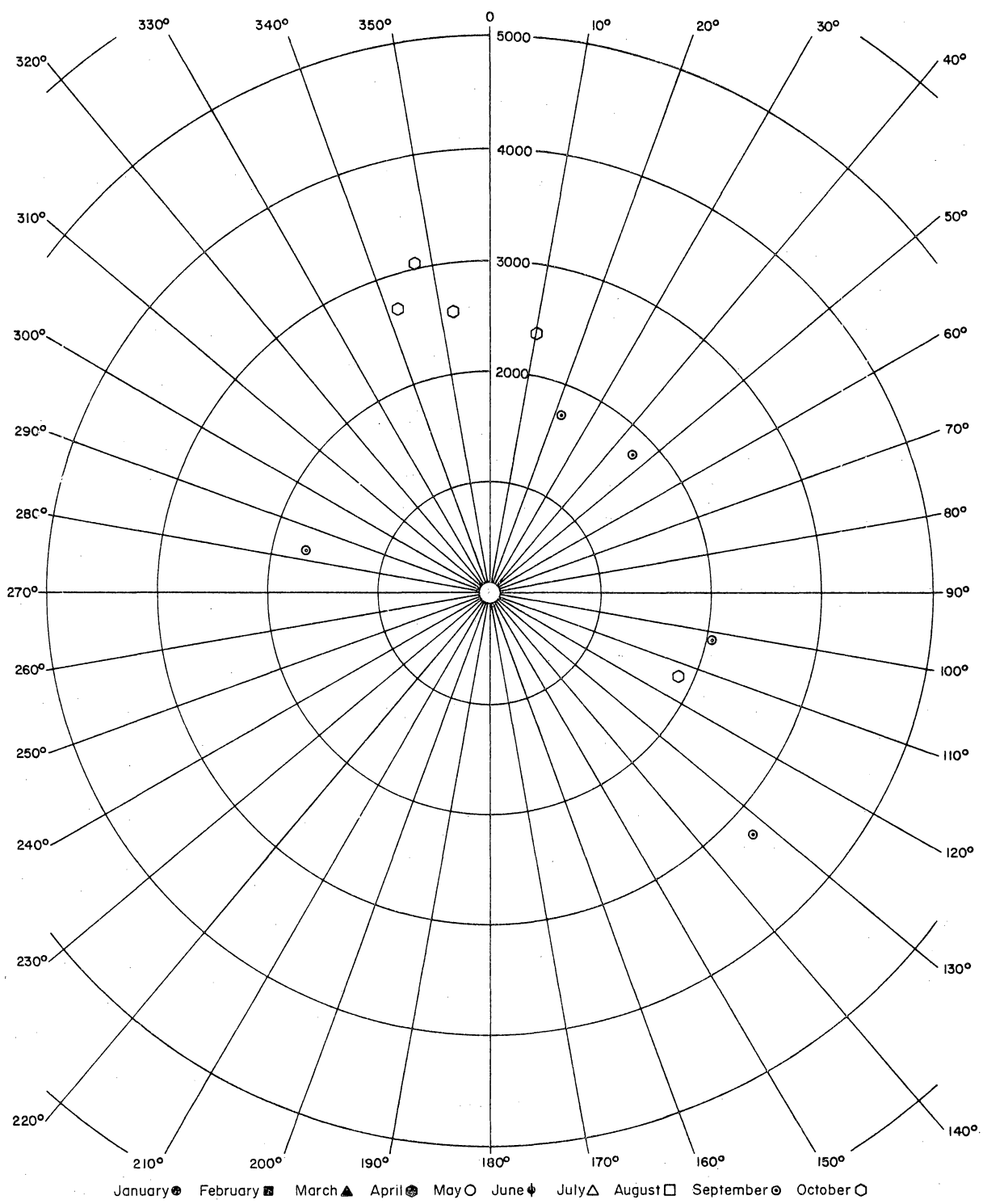

Figure 12g. Methane. Five maximum 3-hour sliding averages per month in micrograms per cubic meter for September through October.

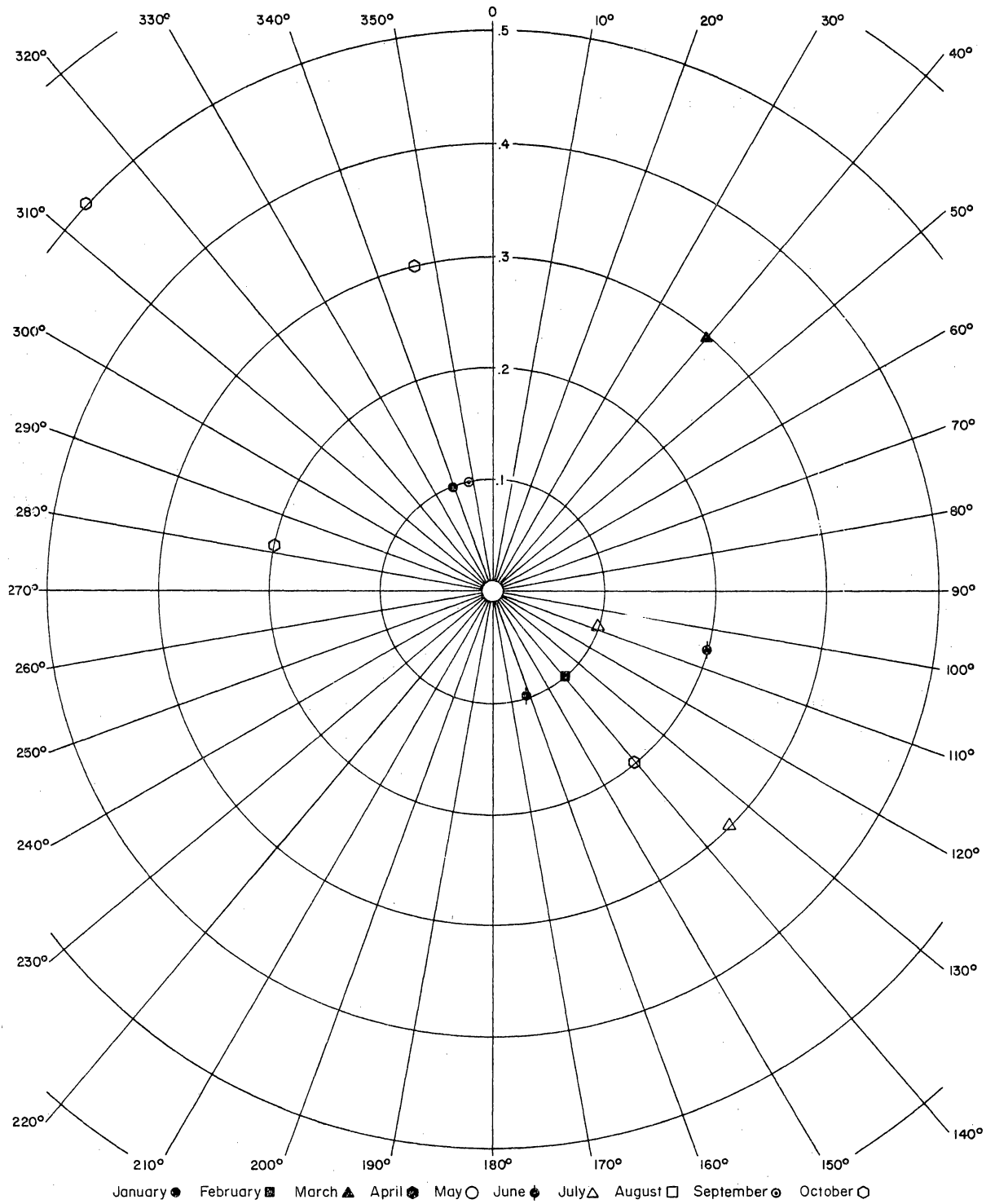

Figure 13a. Daily hydrogen sulfide concentration averages in micrograms per cubic meter for January through October.

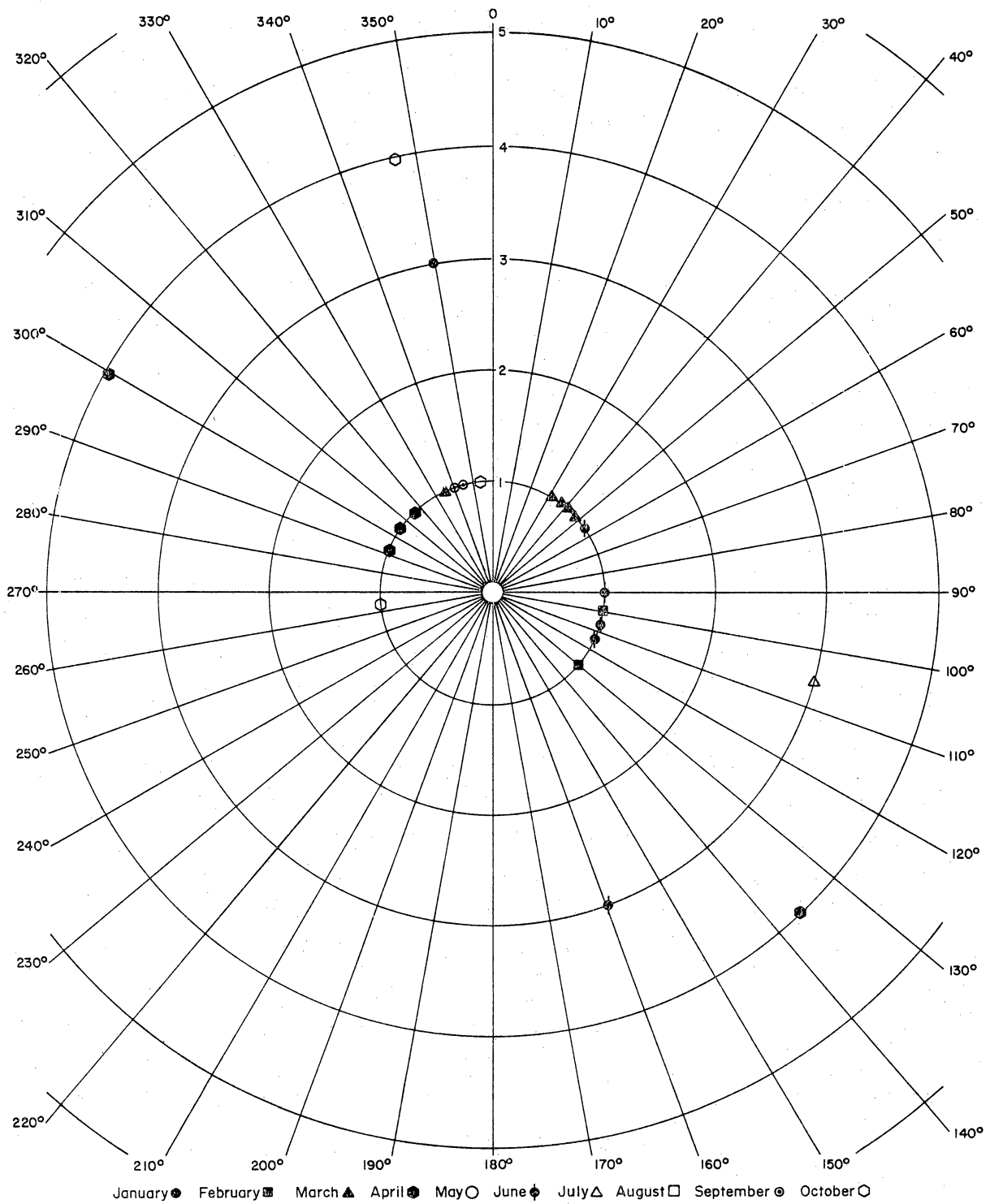

Figure 13b. Hydrogen sulfide. Five maximum 1-hour sliding averages per month in micrograms per cubic meter for January through October.

THE OBJECTIVE OF WATER QUALITY MONITORING IS TO DETERMINE BASELINE WATER QUALITY DATA AT THE GEOPRESSURED GEOTHERMAL TEST WELL SITE OF BOTH SURFACE WATER AND SHALLOW GROUND WATER.

Water chemistry of Chocolate Bayou (table 3) is highly variable because of mixing with marine waters of West Bay.

Water samples were collected monthly from the bayou surface and from just above the floor of the channel. Since November 1978, four sets of samples have been collected monthly, two upstream and two downstream from the test well site.

Major cations (Na, K, Ca, and Mg) and some of the trace elements (B, Mn, Pb, Cd, and Ba) were analyzed by inductively coupled plasma atomic emission spectrometer. Arsenic was determined by distillation-graphite furnace atomic absorption using an IL651A.A. spectrophotometer and an IL555 atomizer. Mercury was measured by cold vapor atomic absorption using a Coleman model MAS050 mercury analyzer. Chloride was determined by titrating with a silver nitrate solution in the presence of potassium chromate as an indicator. Sulfate was measured by a turbidimetric method, using a light scatter path on a Pye-Unicam SP8-100 V.V. spectrophotometer. Fluoride was measured by a selective ion electrode and a Beckman pH meter. Ammonium (NH_4) was steam-distilled with MgO , and NO_3^- was reduced to NH_4^+ with Devarda's Alloy, followed by steam distillation with MgO . Ammonium (NH_4) in distillate was reacted with Nessler's reagent and measured on a spectrophotometer. Dissolved silica was allowed to react with molybdate; the resulting silicomolybdate complex was reduced to a blue color with metolsulfite and ascorbic acid; the color was measured spectrophotometrically.

Water samples from Chocolate Bayou are strongly influenced by marine waters from West Bay and consequently are brackish. The presence of a salt-water wedge

Table 3. Chocolate Bayou, water quality analyses.*

Lab. No.	80-36 upstream shallow Date 1/80	80-37 upstream deep 1/80	80-38 downstream shallow 1/80	80-39 downstream deep 1/80	80-445 upstream shallow 2/80	80-446 upstream deep 2/80	80-447 downstream shallow 2/80	80-448 downstream deep 2/80
Cl ⁻	1654	5890	1800	5596	573	2619	637	2675
SO ₄	110	241	122	246	103	364	108	368
NO ₃	<0.01	<0.01	0.26	0.68	<0.1	0.15	<0.1	0.35
F ⁻	0.48	0.64	0.46	0.57	0.31	0.41	0.29	0.36
Na ⁺	984	3188	1169	3167	348	1460	368	1480
K ⁺	32	115	37	115	15.7	80	16.1	80
Ca ⁺⁺	96	132	100	129	61.7	99	105.8	132.4
Mg ⁺⁺	108.2	400	112.6	401	51.0	183.9	53.0	185.8
SiO ₂	12.9	4.6	9.6	4.1	10.6	7.2	10.8	7.2
B	0.58	1.08	0.47	0.89	0.11	0.47	0.11	0.51
Mn ⁺⁺	0.10	0.36	0.09	0.33	0.09	0.02	0.03	0.09
Pb	<0.01	<0.01	<0.01	<0.01	<0.01	<0.01	<0.01	<0.01
As	1.8	6.6	2	4.3	3	1	1	3
Ba	0.70	0.54	0.70	0.65	0.24	0.23	0.22	0.24
Cd	0.03	0.11	0.04	0.12	0.03	0.01	0.01	0.01
NH ₃	0.26	0.60	0.17	0.62	0.55	0.51	0.28	0.52
Hg	<0.1	<0.1	<0.1	<0.1	1	1	1	1

*Data measured in mg/L.

Table 3 (cont.)

Lab. No.	80-854 upstream shallow Date 3/80	80-855 upstream deep 3/80	80-856 downstream shallow 3/80	80-857 downstream deep 3/80	80-1164 upstream shallow 4/80	80-1163 upstream deep 4/80	80-1166 downstream shallow 4/80	80-1165 downstream deep 4/80
Cl ⁻	3203	3270	3280	3308	174	287	738	200
SO ₄	432	449	435	432	44	53.6	126	44
NO ₃	<0.1	0.8	0.3	0.9	1.8	2	2.5	2.2
F ⁻	0.4	0.4	0.4	0.4	0.3	0.3	0.3	0.3
Na ⁺	1740	1860	1820	1840	114	182	480	134
K ⁺	90	91	90	91	4	6.1	15.2	4.5
Ca ⁺⁺	146	149	146	148	72.9	72.4	77.5	72.9
Mg ⁺⁺	209	215	202	246	19.5	25.5	52.5	21.4
SiO ₂	6.8	7.1	7.1	6.8	13	13	11	1
B	0.59	0.55	0.56	0.56	0.05	0.05	0.05	0.05
Mn ⁺⁺	0.09	0.11	0.09	0.08	0.02	0.02	0.02	0.02
Pb	0.07	0.07	0.06	0.05	0.1	0.1	0.1	0.1
As	<1	1	2	<1	1	1	1	1
Ba	0.31	0.27	0.20	0.21	0.16	0.16	0.16	0.16
Cd	0.03	0.03	0.03	0.03	0.01	0.01	0.01	0.01
NH ₃	0.5	0.6	0.7	0.7	0.2	0.2	0.5	0.2
Hg	1	1	1	1	1	1	1	1

*Data measured in mg/L.

Table 3 (cont.)

Lab. No.	80-1472 upstream shallow 5/80	80-1470 upstream deep 5/80	80-1473 downstream shallow 5/80	80-1471 downstream deep 5/80	80-1605 upstream shallow 6/80	80-1603 upstream deep 6/80	80-1606 downstream shallow 6/80	80-1604 downstream deep 6/80
Cl ⁻	3740	4000	3650	3790	59.6	62.4	63.8	63.8
SO ₄	711	721	682	711	46	41	49	46
NO ₃	2.5	2.6	2.8	2.7	2.2	2	2	1.7
F ⁻	0.5	0.5	0.5	0.5	0.4	0.4	0.4	0.4
Na ⁺	2327	2349	2302	2338	40	41	43	42
K ⁺	73	74.4	72.4	74.1	3	2.8	3.1	3
Ca ⁺⁺	132	134	133	132	47	47	47	46
Mg ⁺⁺	250	252	249	253	12.2	12.3	12.3	12.3
SiO ₂	7.6	7.5	7.7	7.6	16.0	16.2	15.5	15.6
B	0.5	0.46	0.23	0.41	<0.06	<0.06	<0.06	<0.06
Mn ⁺⁺	0.03	0.02	0.02	0.02	<0.02	<0.02	<0.02	<0.02
Pb	<0.1	<0.1	<0.1	<0.1	<0.1	<0.1	<0.1	<0.1
As	1	2	2	2	3	2	3	2
Ba	0.21	0.21	0.21	0.21	0.10	0.10	0.10	0.10
Cd	<0.01	<0.01	<0.01	<0.01	<0.01	<0.01	<0.01	<0.01
NH ₃	0.8	0.7	0.4	0.6	0.3	0.3	0.3	0.4
Hg	1	<1	1	1	<1	<1	<1	<1

*Data measured in mg/L.

Table 3 (cont.)

Lab. No.	80-1691	80-1689	80-1692	80-1690	80-1882	80-1880	80-1883	80-1881
Location	upstream	upstream	downstream	downstream	upstream	upstream	downstream	downstream
Date	shallow	deep	shallow	deep	shallow	deep	shallow	deep
	7/80	7/80	7/80	7/80	8/80	8/80	8/80	8/80
Cl ⁻	439	4670	488	1100	565	4320	693	3985
SO ₄	110	779	112	210	92.7	687	101	649
NO ₃	<0.1	<0.1	0.2	0.1	0.4	<0.1	0.3	0.3
F ⁻	0.5	0.6	0.4	0.5	0.4	0.6	0.4	0.6
Na ⁺	272	2730	297	688	352	2464	448	2283
K ⁺	9.6	95.9	10.6	24	13.4	89.7	16.4	83.8
Ca ⁺⁺	71	147	71.5	83.2	80	142	79.3	137
Mg ⁺⁺	39.2	321	41.7	84.4	47.3	296	57.0	273
SiO ₂	16.8	12.7	16.2	15.8	11.2	8.6	11.2	8.8
B	<0.6	<0.06	<0.06	<0.06	0.3	0.9	0.3	0.8
Mn ⁺⁺	0.03	0.46	0.03	0.05	<0.03	0.3	<0.03	0.2
Pb	<0.1	<0.1	<0.1	<0.1	<0.1	<0.1	<0.1	<0.1
As	3	2	3	3	2	2	2	3
Ba	<0.01	<0.01	<0.01	<0.01	0.1	0.2	0.1	0.2
Cd	<0.02	<0.02	<0.02	<0.02	0.01	0.02	0.04	0.02
NH ₃	0.3	4.29	0.1	0.1	0.1	0.6	0.1	0.6
Hg	<1	<1	<1	<1	<1	<1	<1	<1

*Data measured in mg/L.

Table 3 (cont.)

Lab. No.	80-1919 upstream shallow Date 9/80	80-1917 upstream deep 9/80	80-1920 downstream shallow 9/80	80-1918 downstream deep 9/80	80-2346 upstream shallow 10/80	80-2344 upstream deep 10/80	80-2347 downstream shallow 10/80	80-2345 downstream deep 10/80
Cl ⁻	3451	9081	3734	4126	5446	6952	5338	6402
SO ₄	466	1260	536	565	851	1054	809	927
NO ₃	0.2	<0.1	<0.10	0.8	0.92	1.87	<0.1	0.23
F ⁻	0.8	0.7	0.8	0.9	0.6	0.6	0.5	0.9
Na ⁺	1974	5000	2156	2432	2958	3663	2927	3534
K ⁺	67.2	170	72.9	81.7	97.7	120	97.5	117
Ca ⁺⁺	147	232	154	161	144	166	143	162
Mg ⁺⁺	237	595	257	287	351	438	345	416
SiO ₂	8.4	5.6	8.3	8.1	15.2	10.2	15	13
B	0.62	0.88	0.71	0.78	0.82	0.87	0.82	0.86
Mn ⁺⁺	0.05	0.15	0.05	0.04	0.07	0.07	0.07	0.07
Pb	<0.1	<0.1	<0.1	<0.1	<0.10	<0.10	<0.10	<0.10
As	2	2	2	3	1	<1	<1	2
Ba	0.23	0.19	0.27	0.27	0.13	0.13	0.12	0.12
Cd	0.05	0.14	0.04	0.04	0.08	0.09	0.08	0.09
NH ₃	0.2	0.6	0.4	0.2	3.11	3.13	1.07	1.42
Hg	<1	<1	1	<1	1	1.1	<1	<1

*Data measured in mg/L.

along the floor of the bayou is indicated by consistently high salinities of bayou bottom samples and relatively low surface salinities. The salinity of surface samples varies from 59 to 5,446 mg/L for chloride, indicating that the degree of mixing with marine waters varies and that a wide range in salinities can be expected for bayou waters.

Analyses of shallow ground water near this test well site indicate only a minor influence from mixing with salt water.

Analyses of ground water from the Pleasant Bayou #1 and #2 test well site began in November 1978, and continued throughout 1980 (table 4). Wells were drilled until appreciable flow of ground water was reached and then were screened and lined with 4-inch (10-cm) PVC pipe. Monthly samples are being taken by installing a portable pump and pumping the well to remove all water standing in the pipe. Only then are samples collected. Sampling depths are approximately 40 ft (12.2 m) in each well (fig. 9).

Concentrations of sodium and chlorine in analyses of shallow ground water suggest that ground water is essentially fresh, being little influenced by salt intrusion from the bayou. Salinity values from well #2 are higher possibly because well #2 lies closer to both West Bay and Chocolate Bayou than do monitoring wells #1 and #3 (fig. 9).

Table 4. Pleasant Bayou geothermal test well area, shallow ground-water analyses.*

Lab. No. Location Date	80-40 Well #1 1/80	80-41 Well #2 1/80	80-42 Well #3 1/80	80-442 Well #1 2/80	80-443 Well #2 2/80	80-444 Well #3 2/80
Cl ⁻	110	298	169	120	283	148
SO ₄	18.7	34	20.5	15.7	29.1	16.1
NO ₃	<0.01	0.40	<0.01	<0.1	<0.1	0.29
F ⁻	0.52	0.37	0.39	0.45	0.28	0.32
Na ⁺	154	235	81.2	123	210	80.9
K ⁺	3.3	4.5	4.5	3	4.6	4.3
Ca ⁺⁺	99	122	122	125.4	80.3	92.5
Mg ⁺⁺	16.7	23.2	24.7	17.6	24	25.7
SiO ₂	23.4	28.2	26.3	19	22.7	20.3
B	0.07	0.16	0.12	0.06	0.02	0.02
Mn ⁺⁺	0.03	0.28	0.16	0.04	0.27	0.17
Pb	<0.01	<0.01	<0.01	<0.01	<0.01	<0.01
Ba	0.56	0.91	0.65	0.21	0.37	0.26
NH ₃	0.32	0.05	0.17	0.36	0.78	0.19
Hg	<0.1	<0.1	<0.1	1	1	2
As	1.4	2.6	7	1	1	2
Cd	0.01	0.01	0.01	0.01	0.01	0.01

*Data measured in mg/L.

Table 4 (cont.)

Lab. No. Location Date	80-851 Well #1 3/80	80-852 Well #2 3/80	80-853 Well #3 3/80	80-1160 Well #1 4/80	80-1161 Well #2 4/80	80-1162 Well #3 4/80
Cl ⁻	116	278	151	108	281	153
SO ₄	15.4	26.6	17.4	17.2	27.6	18
NO ₃	<0.1	<0.1	<0.1	0.4	0.1	0.1
F ⁻	0.4	0.2	0.3	0.4	0.3	0.3
Na ⁺	121	205	79	116	219	85
K ⁺	3.5	5.5	4	0.5	1.5	1
Ca ⁺⁺	78.3	130	132	97	129	138
Mg ⁺⁺	15.5	21	23	15.6	20.8	23.6
SiO ₂	19.8	23.6	21	20	23	20
B	0.04	0.08	0.04	0.05	0.05	0.05
Mn ⁺⁺	0.04	0.24	0.13	0.04	0.24	0.11
Pb	0.03	0.04	0.03	0.1	0.1	0.1
Ba	0.19	0.36	0.25	0.15	0.28	0.20
NH ₃	0.2	0.2	0.2	0.3	0.2	0.3
Hg	1	1	1	1	1	1
As	<1	1	1	1	1	1
Cd	<0.01	0.01	<0.01	0.01	0.01	0.01

*Data measured in mg/L.

Table 4 (cont.)

Lab. No. Location Date	80-1467 Well #1 5/80	80-1468 Well #2 5/80	80-1469 Well #3 5/80	80-1601 Well #1 6/80	80-1602 Well #2 6/80
Cl ⁻	127	307	183	114	155
SO ₄	32	43	31	27	29
NO ₃	<0.1	<0.1	<0.1	0.1	0.1
F ⁻	0.4	0.3	0.3	0.4	0.3
Na ⁺	111	220	76.6	102	74
K ⁺	0.6	1.4	1.1	0.9	1.6
Ca ⁺⁺	100	130	130	99	130
Mg ⁺⁺	15.1	20.9	22.1	16.8	24
SiO ₂	20.1	24	22.2	19.7	21.4
B	<0.05	<0.05	<0.05	<0.06	<0.06
Mn ⁺⁺	0.08	0.35	0.26	0.07	0.14
Pb	<0.1	<0.1	<0.1	<0.1	<0.1
Ba	0.18	0.28	0.20	0.16	0.18
NH ₃	0.4	0.1	0.5	0.4	0.1
Hg	1	<1	<1	<1	<1
As	1	2	1	1	1
Cd	<0.01	<0.01	<0.01	<0.01	<0.01

*Data measured in mg/L.

Table 4 (cont.)

Lab. No. Location Date	80-1686 Well #1 7/80	80-1687 Well #2 7/80	80-1688 Well #3 7/80	80-1877 Well #1 8/80	80-1878 Well #2 8/80	80-1879 Well #3 8/80
Cl ⁻	122	284	163	110	293	156
SO ₄	30.3	37	29.7	1.3	39.2	28
NO ₃	0.3	<0.1	0.1	0.4	0.1	0.2
F ⁻	0.4	0.2	0.3	0.4	0.3	0.3
Na ⁺	106	207	85.2	104	212	82.8
K ⁺	0.6	1.3	1.3	<1.3	1.5	1.8
Ca ⁺⁺	104	128	134	100	127	142
Mg ⁺⁺	16.1	21.5	23.7	15.8	21.1	25.2
SiO ₂	19.5	23.7	21.4	13.2	16.5	14.9
B	<0.06	<0.06	<0.06	0.2	0.06	0.4
Mn ⁺⁺	0.05	0.22	0.11	0.03	<0.03	0.1
Pb	<0.1	<0.1	<0.1	<0.1	<0.1	<0.1
Ba	<0.01	<0.01	<0.01	0.1	<0.1	0.2
NH ₃	0.3	0.3	0.2	<0.1	0.1	<0.1
Hg	<1	<1	<1	<1	<1	<1
As	1	1	3	1	3	2
Cd	<0.02	<0.02	<0.02	0.02	<0.01	0.02

*Data measured in mg/L.

Table 4 (cont.)

Lab. No. Location Date	80-1914 Well #1 9/80	80-1915 Well #2 9/80	80-1916 Well #3 9/80	80-2341 Well #1 10/80	80-2342 Well #2 10/80	80-2343 Well #3 10/80
Cl ⁻	123	299	164	112	270	174
SO ₄	26	33.3	24.1	26.6	34.4	27.3
NO ₃	0.5	0.7	0.2	2.2	0.82	0.86
F ⁻	0.4	0.3	0.3	0.4	0.3	0.3
Na ⁺	113	222	95	91	200	72.4
K ⁺	0.8	1.5	1.3	0.61	1.35	1
Ca ⁺⁺	110	133	142	102	122	127
Mg ⁺⁺	17	22.4	25.3	15	20	22.2
SiO ₂	11.8	14.4	13.5	19.5	21.8	22
B	0.10	0.12	0.10	<0.10	0.20	<0.10
Mn ⁺⁺	0.05	0.25	0.12	0.07	0.25	0.10
Pb	<0.1	<0.1	<0.1	<0.10	<0.10	<0.10
Ba	0.22	0.27	0.23	0.20	0.28	0.20
NH ₃	0.3	0.1	0.1	0.15	0.21	0.11
Hg	<1	<1	<1	<1	<1	1.2
As	2	2	3	1	2	2
Cd	0.01	0.01	0.01	0.01	0.01	0.01

*Data measured in mg/L.

ACKNOWLEDGMENTS

This research was performed under contract to the U.S. Department of Energy, Division of Geothermal Energy (contract number DE-AC08-79ET27111, Thomas C. Gustavson, Principal Investigator). Water chemistry analyses were conducted at the Mineral Studies Laboratory of the Bureau of Economic Geology under the direction of Clara L. Ho. Preparation of illustrations was supervised by James Macon and Dan Scranton; word processing was done by Margaret Chastain and was supervised by Lucille Harrell; editing was by Rebecca P. Lasley. Text illustrations were photographed by James A. Morgan. Robert A. Morton reviewed the manuscript.

REFERENCES

Bebout, D. G., Agagu, O. K., and Dorfman, M. H., 1975a, Geothermal resources, Frio Formation, middle Texas Gulf Coast: The University of Texas at Austin, Bureau of Economic Geology Geological Circular 75-8, 43 p.

Bebout, D. G., Dorfman, M. H., and Agagu, O. K., 1975b, Geothermal resources, Frio Formation, South Texas: The University of Texas at Austin, Bureau of Economic Geology Geological Circular 75-1, 36 p., maps.

Bebout, D. G., Loucks, R. G., Bosch, S. C., and Dorfman, M. H., 1976, Geothermal resources, Frio Formation, upper Texas Gulf Coast: The University of Texas at Austin, Bureau of Economic Geology Geological Circular 76-3, 47 p.

Bebout, D. G., Loucks, R. G., and Gregory, A. R., 1978, Frio sandstone reservoirs in the deep subsurface along the Texas Gulf Coast--their potential for the production of geopressured geothermal energy: The University of Texas at Austin, Bureau of Economic Geology Report of Investigations 91, 93 p.

Gustavson, T. C., 1979, Environmental baseline monitoring in the vicinity of General Crude Oil-Department of Energy Pleasant Bayou Number 1--a geopressured geothermal test well--1978: The University of Texas at Austin, Bureau of Economic Geology, prepared for U.S. Department of Energy, Division of Geothermal Energy under contract no. DE-AS05-77ET27031, 420 p.

Gustavson, T. C., Howard, R. C., and McGookey, Douglas, 1980, Environmental baseline monitoring in the area of General Crude Oil-Department of Energy

Pleasant Bayou Number 2--a geopressured geothermal test well--1979: The University of Texas at Austin, Bureau of Economic Geology, prepared for U.S. Department of Energy, Division of Geothermal Energy under contract no. DE-AS05-77ET28504, 303 p.

Gustavson, T. C., and Kreitler, C. W., 1976, Geothermal resources of the Texas Gulf Coast--environmental concerns arising from the production and disposal of geothermal waters: The University of Texas at Austin, Bureau of Economic Geology Geological Circular 76-7, 35 p.

Gustavson, T. C., McGraw, M. M., Tandy, Mills, Parker, Faust, and Wohlschlag, D. E., 1978, Ecological implication of geopressured-geothermal energy development, Texas-Louisiana Gulf Coast region: U.S. Fish and Wildlife Service, FWS/OBS/78/60, 600 p.

Healy, J. A., Rubey, W. W., Griggs, D. T., and Raleigh, C. B., 1968, The Denver earthquakes: Science, v. 161, no. 3848, p. 1301-1310.

Raleigh, C. B., Healy, J. H., and Bredehoeft, J. D., 1972, Faulting and crustal stress at Rangely, Colorado: American Geophysical Union, Geophysical Monographs, v. 16, p. 275-284.

_____ 1976, An experiment in earthquake control at Rangely, Colorado: Science, v. 191, p. 1230-1237.

Teledyne Geotech, 1978, A reconnaissance microseismic survey of the Brazoria County geophysical well test region: Garland, Texas, Teledyne Geotech, Technical Report TR 78-6, 25 p.

Teledyne Geotech, 1980, Microseismicity at the Brazoria County geopressured reservoir: Garland, Texas, Teledyne Geotech, Technical Report TR 80-3, 30 p.

White, W. A., McGraw, Maryann, and Gustavson, T. C., 1978, Environmental analysis of geopressured geothermal prospect areas, Brazoria and Kenedy Counties, Texas: The University of Texas at Austin, Bureau of Economic Geology, prepared for the U.S. Department of Energy, Division of Geothermal Energy under contract no. EG-77-S-05-5401, 203 p.

Appendix I: Air Quality Monitoring

APPENDIX I

I. GENERAL DESCRIPTION OF AIR MONITORING PROGRAM

Radian Corporation is under contract to the University of Texas, Bureau of Economic Geology, to provide ambient air quality monitoring at one site near Chocolate Bayou, Texas. This site measures and records concentrations of sulfur dioxide, hydrogen sulfide, methane, and particulates. A bag sample is collected bi-weekly and returned to Radian's Austin facilities and analyzed for methane.

Figure I shows the configuration of this type of monitoring station. The trailer provides a sturdy and protective covering as well as mobility. Figure II shows the air monitoring site.

FIGURE I

AMBIENT AIR MONITORING SYSTEM I

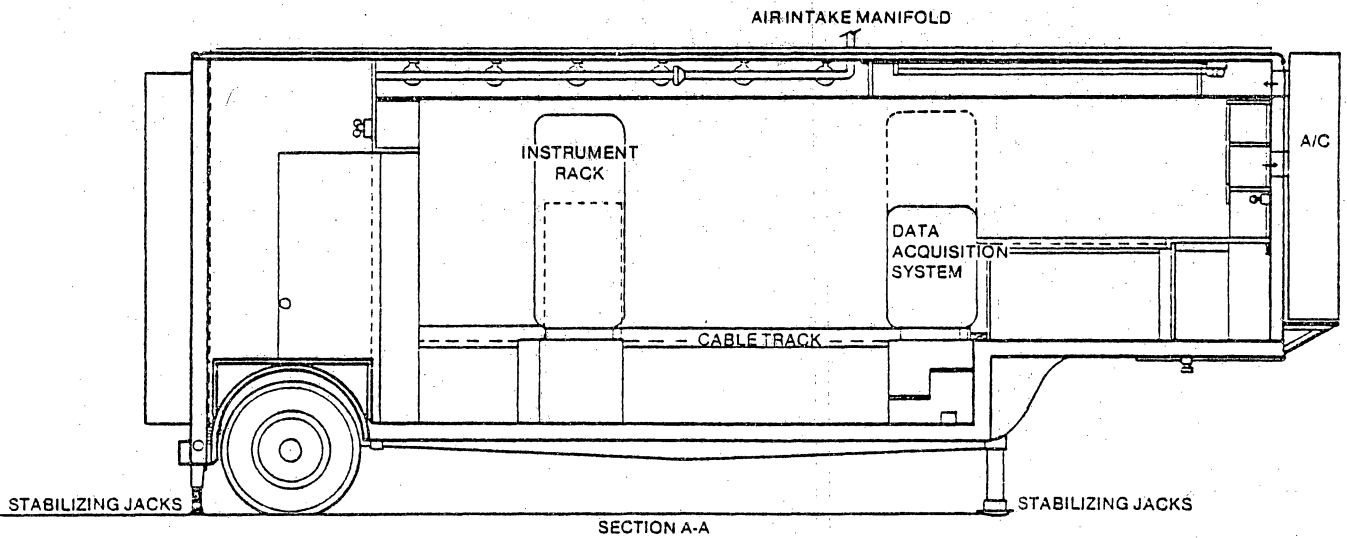
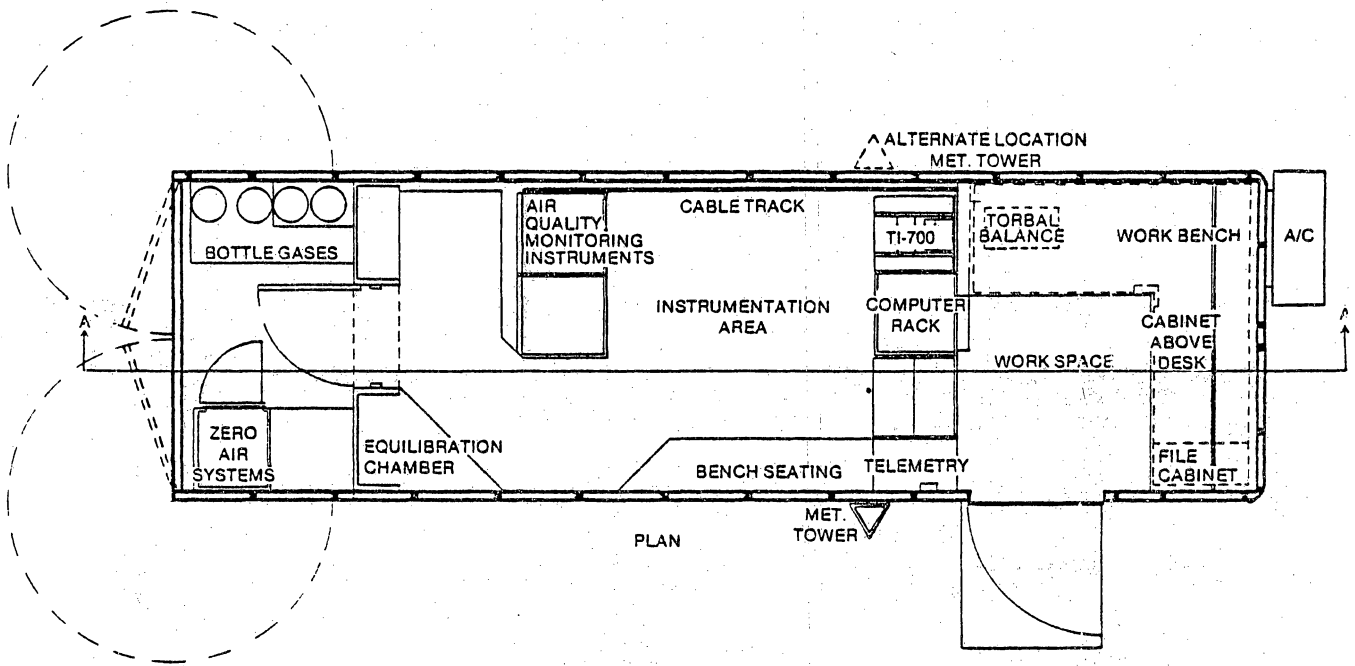

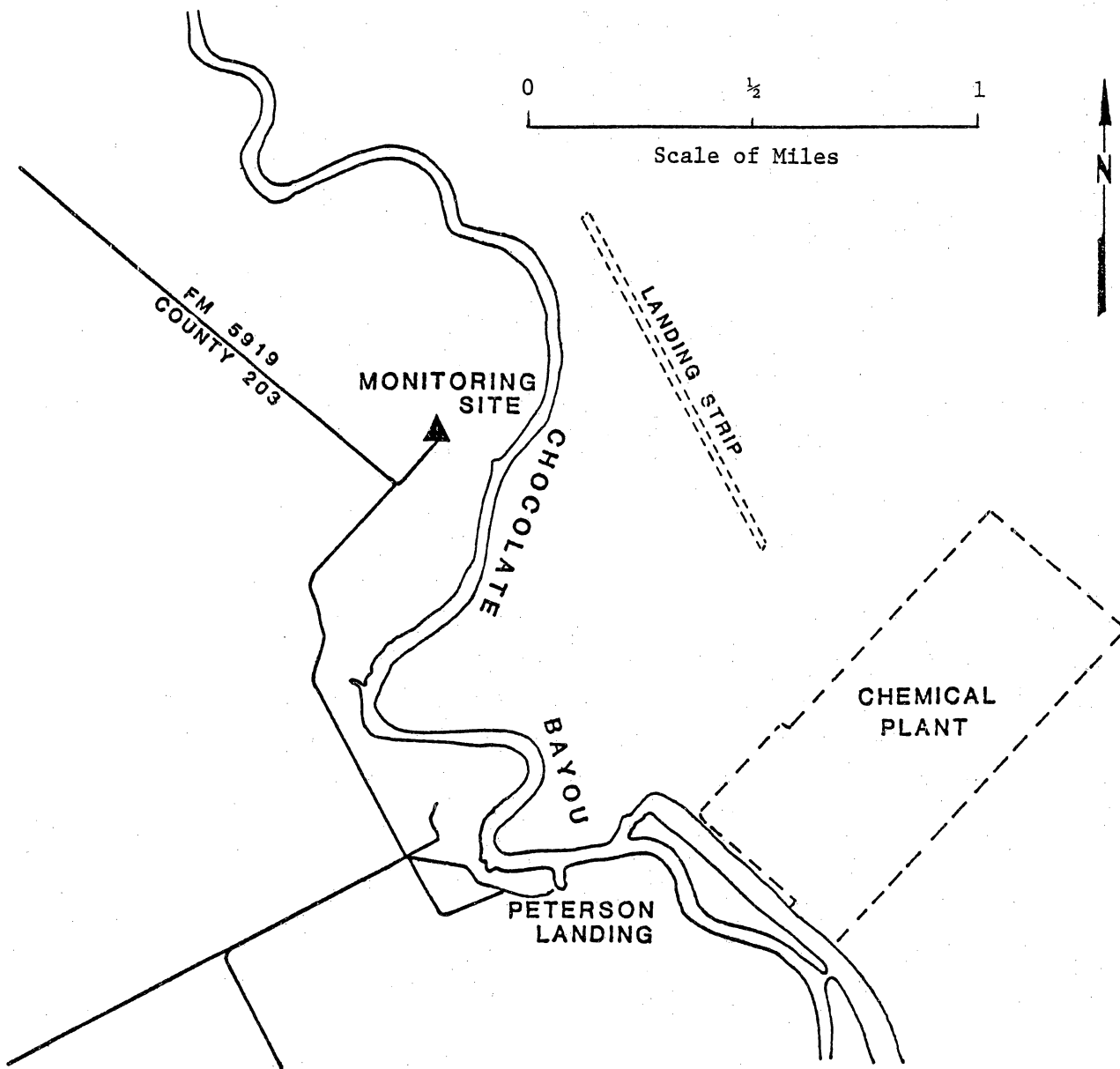

FIGURE II
AIR MONITORING SITE

II. DESCRIPTION OF INSTRUMENT SYSTEMS (JANUARY-FEBRUARY)

The ambient air monitoring station is equipped to monitor the parameters shown below:

Sulfur Dioxide
Particulates
Methane
Hydrogen Sulfide

A. Air Quality Instrumentation

1. Description

Sulfur dioxide is measured with a Meloy Model SA185-2A sulfur analyzer, which is an EPA-approved analyzer. This automated analyzer utilizes the flame photometric principle to measure sulfur levels with a minimum detectable sensitivity of 5 ppb, and a linearity of $\pm 1\%$. The analyzer is operated with an H₂S scrubber to make it specific to SO₂ concentrations.

Hydrogen sulfide is measured using a Meloy Model SA185-2 analyzer equipped with an SO_x scrubber. Specifications for this analyzer are the same as for the SA185-2A.

Methane is monitored with a Bendix Model 8200 gas chromatograph. This instrument uses a flame ionization detector and has a minimum detectable sensitivity of 5 ppb. The Model 8200 works on a five-minute cycle, i.e., one air sample is analyzed every five minutes.

The air sample is drawn in through a glass cane and manifold supplied by the Ace Glass Company. The system has a 25 mm diameter, and a constant air flow through the system is

RADIAN CORPORATION

provided by an air pump rated at 60 cfm at 0" head pressure. The manifold has sampling ports to which ½" Teflon lines to the instruments are connected. All joints in the sampling system are secured by O-ring compression fittings. The manifold is contained in a heated (100°F) chamber to prevent condensation of moisture.

The trailer has two heavy duty high volume particulate samplers (Hi-Vols). Fiberglass filter paper is brought to a controlled humidity before weighing. Each Hi-Vol has a flow recorder to permit correction for changes in air flow runs for a 24-hour period (midnight to midnight), and is turned on and off by the computer. The Hi-Vols were designed following guidelines recommended by the Environmental Protection Agency and were manufactured by Radian.

2. Calibration

The trailer contains a Meloy Model RAD-1 calibration unit. This unit provides a zero air supply and SO₂ span gas from an SO₂ permeation tube. The calibration is automatically performed once a day, and is controlled by the computer. The SO₂ channel is first switched to zero. Then the computer monitors the output of each analyzer and takes a new zero reading after a stable zero signal has been reached. This zero reading is compared by the computer to the zero reading obtained 24 hours before, and if a drift in excess of 10 ppb has occurred, an excess zero drift light on the System Status Panel is turned on. The instruments are then returned to the monitor mode, and after two minutes the computer resumes data taking.

The SO₂ permeation tubes were manufactured by Metronics Association, Inc. These tubes were then individually calibrated for Radian by the National Bureau of Standards.

The Model 8200 methane analyzer is calibrated with undiluted span gas. This span gas contains methane in air. The Model 8200 is zeroed with air from a Bendix Model 8834 zero air unit. In addition, the instrument is electronically re-zeroed at the start of every five-minute cycle.

In addition to the daily instrument zero/spans, all instruments are multipoint calibrated monthly. Calibration standards and equipment used in the monthly multipoints is distinct from the equipment used for daily zero/span operations.

Quality assurance audits are performed on each instrument once a quarter. These audits are performed by Radian's Quality Assurance personnel using instrumentation and standards different from those used in the monthly multipoint calibrations.

A General Metals Calibration Kit is used to calibrate the Hi-Vol particulate samplers.

B. Data Acquisition System

The basis of the data acquisition system is a Data General NOVA 1200 minicomputer. The NOVA, which has a basic cycle time of 1.2 μ sec, is equipped with automatic program load and power fail/automatic restart features. The computer utilizes 8K 16-bit words of core memory. Analog-to-digital conversion is accomplished via an ADC built by Radian Corporation. The input/output unit for system 034 is Texas Instruments' KSR 733 keyboard/printer. This model provides keyboard entry and hard copy printed output. The data are also recorded on a cassette magnetic tape unit with three drives. The cassette unit is utilized for program storage and loading as well as recording. To reduce wear on mechanical parts, the power to the teletype and cassette units is turned on only when the

**RADIAN
CORPORATION**

unit(s) is to be used. Several important functions in the instruments as well as in the computer and the trailer are monitored by means of lights on a System Status Panel. The information displayed by these lights is written onto cassette tape to monitor the complete status of the system every five minutes.

III. JANUARY METHANE BAG SAMPLING PROGRAM

Grab-bag samples are collected bi-weekly and analyzed for methane. The ambient air samples are collected in tedlar bags using a metal bellows pump connected to the ambient sample manifold. Each bag sample is collected over a three-hour period.

The bag samples are returned to Austin for analysis for methane concentration. The analysis is performed on either a Bendix 8202 or a Baseline Industries Model 1030 gas chromatograph using a flame ionization detector. The minimum detectable limit using this technique is less than 1 ppm.

Results of the bag sampling analyses are given below:

<u>Date</u>	<u>Time</u>	<u>Methane Concentration (ppm)</u>
1/11/79	0600-0900	6.52
1/22/79	0600-0900	2.74

IV. OPERATING TIME ANALYSIS

This section presents the operating statistics for each of the major subsystems contained in the monitoring station. Table I shows the specific number of hours that each of these subsystems was inoperative for the month. The column labeled "DIGITIZING SYSTEM" refers to the entire data acquisition system, and downtime hours appearing in this column are hours of total data loss. These instances include, in addition to computer downtime, power failures, no power available, and self-automated shutdown periods such as during air conditioner malfunctions.

Calibration time is not considered to be downtime and is not included in the downtime figures. The amount of time used in calibrating the instruments is given at the bottom of the downtime analysis table and is reported as total calibration hours for each channel for the entire month. As is evident in the calibration figures, channels can be calibrated independently of one another. No calibration time is given for particulate monitoring since Hi-Vol calibration occurs infrequently and only during the off-duty cycle for each Hi-Vol while another Hi-Vol is taking data.

TABLE 1.
 DOWNTIME HOURS FOR CHOCOLATE BAYOU, TEXAS, 1980
 (JANUARY)

SITE 033					
DIGITIZING					
DATE	SYSTEM	SO2	H2S	CH4	TSP
1/ 1	0	0	0	0	0
1/ 2	0	0	0	0	-
1/ 3	0	0	0	0	0
1/ 4	0	0	0	0	-
1/ 5	0	0	0	0	-
1/ 6	5	1	0	0	-
1/ 7	0	0	0	0	0
1/ 8	0	0	0	0	-
1/ 9	0	0	0	0	-
1/10	0	0	0	0	0
1/11	0	0	0	0	-
1/12	0	0	0	0	-
1/13	0	0	0	0	0
1/14	0	0	0	0	-
1/15	0	0	0	0	-
1/16	0	0	0	0	0
1/17	0	0	0	0	-
1/18	0	0	0	0	-
1/19	0	0	0	0	0
1/20	0	0	0	0	-
1/21	0	0	0	0	-
1/22	0	0	0	0	0
1/23	0	0	0	0	-
1/24	0	0	0	0	-
1/25	0	0	0	0	0
1/26	0	0	0	0	-
1/27	0	0	0	0	-
1/28	0	0	0	0	0
1/29	0	0	0	0	-
1/30	0	0	0	0	-
1/31	0	0	0	0	0
CAL TIME		32	30	31	
DATA CAPTURE RATE (%)		99	99	99	100

Downtime Summary for January 1980

Data recovery for air quality analyzers was very good, well above 90 percent for entire month.

V. DATA PRESENTATION AND SUMMARY

This section includes summaries for various recorded data at the monitoring sites. The data presentations indicate the variability of pollutant concentrations with time. All parameters, except suspended particulates (24-hour samples), are sampled once each second, but recorded as five-minute arithmetic averages of the one-second samples. The master data base from which the data tables in this report were generated consists of hourly averages computed from the 12 five-minute averages recorded for each hour. This averaging technique tends to smooth instantaneous maximum values.

Inherent in any data acquisition system is random noise, both from the recording instruments and quantization in the analog-to-digital conversion. The lower threshold for all analytical instruments is twice the maximum noise level generated by the instruments. This lower threshold is 5 ppb for all of these instruments. Therefore, any values appearing in the data presentations that are less than 5 ppb indicate only a trace of pollutant in question and should not be construed to be absolute levels. In addition, when concentration levels drop below the lower threshold, the recorded quantity is simply random noise and averages tend toward zero. If a zero concentration appears in the data presentation, this does not indicate absolute zero concentration.

All pollutant data (except for particular data) are taken at the monitoring site in integer parts per billion (ppb) but are presented here in micrograms per cubic meter ($\mu\text{g}/\text{m}^3$) assuming standard temperature and pressure of 25°C and 760 mm Hg (1013.2 millibars), respectively. The scale factors required to convert $\mu\text{g}/\text{m}^3$ at standard conditions back to ppb for the various pollutants are given in the following table.

<u>Pollutant</u>	<u>To Convert $\mu\text{g}/\text{m}^3$ at 25°C and 760 mm Hg to ppb Multiply by</u>
SO ₂	.384
H ₂ S	.723
CH ₄	1.536

The units of the air quality parameters are given at the top of each table. It should be noted here that inside temperature is monitored and recorded as a functional part of the system but is not presented in this report.

It should be noted that the SO₂ scrubber was installed on the H₂S analyzer on 16 August 1978 at 0935. Data from that analyzer from 0935 on that date are H₂S data. Prior to 16 August, the data represented total sulfur measurements.

Table II presents the national ambient air quality standards (NAAQS) for criteria pollutants.

Table III displays the daily and monthly statistics for the monitoring station for the month. To insure statistical significance, and to reduce the possibility of introducing a bias in the presentation, averages are computed only when at least 50 percent of the hourly averages subject to averaging are present. If less than the required number of hourly values are present for a particular parameter, that entry will be blank. The number of values present for a particular parameter is defined as the total possible number of hourly values for the averaging period less the computer downtime less the channel downtime less the channel calibration time. A blank entry indicates an insufficient number of hourly values present for that day. The averages in Table III are arithmetic averages of the hourly averages with the following exception:

Particulate monthly averages are computed as the geometric mean.

Table IV indicates the five largest averages for various averaging times. The table shows the period of time covered by the average. Maxima are chosen so that time segments are independent. The maximum averages reported are found using a 'sliding average' technique with the exception of the 24-hour particulate average, which is computed from midnight to midnight. For all averaging times, the sliding average is stepped one sample at a time. For averaging times less than or equal to 8 hours, 100 percent of the hourly averages must be present to compute a sliding average. Averaging times greater than 8 hours require 90 percent. Whether or not a sliding average is computed is solely determined by the number of samples present in that averaging time and is independent of daily or monthly averaging criteria. This sliding average technique conforms to the methodology described in the EPA Guideline Series, OAQPS No. 1.2-008, revised February 1977, entitled "Guidelines for the Interpretation of Air Quality Standards."

Table V presents hourly averages of the recorded parameters. All daily (right-hand column), diurnal (bottom line), and monthly (bottom) averages are arithmetic averages of the associated hourly averages. For all parameters, a blank entry in the hourly average table indicates that less than one-third (i.e., less than 4) of the five-minute averages for that hour are present.

Times given in the data presentations correspond to the appropriate local times, i.e., Central Daylight Savings Time or Central Standard Time, depending on the time of the year.

TABLE 2

FEDERAL AND TEXAS STATE AMBIENT AIR QUALITY STANDARDS (JANUARY)

Agency	Pollutant	Special Conditions		$\mu\text{g}/\text{m}^3$ Primary	(PPM)	$\mu\text{g}/\text{m}^3$ Secondary	(PPM)	
Federal and Texas	SO ₂		Annual	80	.03			
			24-Hour*	365	.14			
			3-Hour*	---		1300	.5	
Texas	SO ₂	All Counties Except	30-Minute**	1061	.4	----		
			Harris, Galveston	30-Minute**	743	.28	----	
				Orange, Jefferson	30-Minute**	849	.32	----
Federal and Texas	Particulate		Annual***	75		60		
			24-Hour*	260		150		
Texas	Particulate		5-Hour**	100		---		
			3-Hour**	200		---		
			1-Hour**	400		---		
Federal and Texas	CO		8-Hour*	10,000	9.	10,000	9.	
			1-Hour*	40,000	35.	40,000	35.	
Federal and Texas	Photochemical Oxidant HC (Non-Methane) NO ₂	6-9 a.m.	1-Hour†	235	.12	235	.12	
			3-Hour*	160	.24	160	.24	
			Annual	100	.05	100	.05	

*Not to be exceeded more than once per year.

**Texas special regulations. Single plant source may not exceed these ambient levels in Texas at any point, at any time.

***Geometric Mean.

†The expected number of exceedances not to occur on more than one calendar day per year.

TABLE 3. DAILY AVERAGES FOR JAN 1 1980 THRU JAN 31 1980

	SULFUR DIOXIDE (UG/M**3)	HYDROGEN SULFIDE (UG/M**3)	METHANE((UG/M**3)X10**-1)
SITE DATE	033	033	033
JAN 01	0.2	0.0	131.3
JAN 02	0.0	0.0	114.2
JAN 03	0.0	0.0	118.2
JAN 04	0.0	0.0	122.1
JAN 05	0.0	0.0	129.4
JAN 06	0.0	0.0	104.6
JAN 07	5.0	0.0	117.3
JAN 08	2.6	0.0	130.6
JAN 09	5.6	0.0	135.4
JAN 10	0.0	0.0	118.7
JAN 11	0.0	0.0	111.3
JAN 12	0.0	0.0	110.7
JAN 13	0.0	0.0	109.8
JAN 14	0.0	0.0	111.7
JAN 15	0.0	0.0	116.6
JAN 16	0.0	0.0	115.6
JAN 17	0.0	0.0	126.7
JAN 18	0.6	0.0	153.7
JAN 19	0.0	0.0	118.9
JAN 20	0.0	0.0	114.3
JAN 21	0.0	0.0	102.5
JAN 22	0.0	0.1	110.1
JAN 23	0.0	0.0	112.8
JAN 24	0.0	0.0	119.2
JAN 25	0.0	0.0	113.0
JAN 26	1.1	0.0	146.0
JAN 27	0.0	0.0	131.5
JAN 28	0.0	0.0	126.9
JAN 29	0.0	0.0	138.0
JAN 30	0.0	0.0	131.0
JAN 31	0.0	0.0	122.2
JAN 01 -31	0.5	0.0	121.5

TABLE 3. DAILY AVERAGES FOR JAN 1 1980 THRU JAN 31 1980 (cont.)

TOTAL SUSPENDED PARTICULATE(UG/M**3)

SITE	033
DATE	
JAN 01	17.0
JAN 02	
JAN 03	20.0
JAN 04	
JAN 05	
JAN 06	
JAN 07	40.0
JAN 08	
JAN 09	
JAN 10	23.0
JAN 11	
JAN 12	
JAN 13	41.0
JAN 14	
JAN 15	
JAN 16	24.0
JAN 17	
JAN 18	
JAN 19	39.0
JAN 20	
JAN 21	
JAN 22	25.0
JAN 23	
JAN 24	
JAN 25	17.0
JAN 26	
JAN 27	
JAN 28	45.0
JAN 29	
JAN 30	
JAN 31	42.0
JAN 01 -31	28.4

TABLE 4. THE FIVE MAXIMUM INDEPENDENT SLIDING AVERAGES FOR JAN 1, 1980 - JAN 31, 1980

SITE		033
SULFUR DIOXIDE (UG/M**3) 3-HOUR		
1.	1/ 7(17:00-20:00)	38.0
2.	1/ 9(5:00- 8:00)	27.6
3.	1/ 8(17:00-20:00)	17.3
4.	1/ 9(21:00- 0:00)	15.0
5.	1/26(10:00-13:00)	8.6

SITE		033
SULFUR DIOXIDE (UG/M**3) 24-HOUR		
1.	1/ 8(8:00- 8:00)	6.1
2.	1/ 6(20:00-20:00)	4.8
3.	1/ 9(8:00- 8:00)	1.8
4.	1/25(13:00-13:00)	1.1
5.	1/17(15:00-15:00)	0.5

SITE		033
TOTAL SUSPENDED PARTICULATE (UG/M**3) 24-HOUR		
1.	1/28(0:00- 0:00)	45.0
2.	1/31(0:00- 0:00)	42.0
3.	1/13(0:00- 0:00)	41.0
4.	1/ 7(0:00- 0:00)	40.0
5.	1/19(0:00- 0:00)	39.0

TABLE 4. THE FIVE MAXIMUM INDEPENDENT SLIDING AVERAGES FOR JAN 1, 1980 - JAN 31, 1980
(cont.)HYDROGEN SULFIDE (UG/M**3)
1-HOUR

SITE	033
1.	1/22(12:00-13:00) 3.0
2.	1/ 1(1:00- 2:00) 0.0
3.	1/ 1(2:00- 3:00) 0.0
4.	1/ 1(3:00- 4:00) 0.0
5.	1/ 1(0:00- 1:00) 0.0

METHANE ((UG/M**3)X10**-1)
6-9 AM

SITE	033
1.	1/18(6:00- 9:00) 228.3
2.	1/ 1(6:00- 9:00) 175.0
3.	1/ 5(6:00- 9:00) 168.0
4.	1/29(6:00- 9:00) 159.0
5.	1/ 9(6:00- 9:00) 145.3

SULFUR DIOXIDE (UG/M**3)
1-HOUR

SITE	033
1.	1/ 7(18:00-19:00) 81.0
2.	1/ 9(6:00- 7:00) 57.0
3.	1/ 9(22:00-23:00) 39.0
4.	1/ 8(18:00-19:00) 34.0
5.	1/ 9(7:00- 8:00) 26.0

TABLE 5. HOURLY AVERAGES OF SULFUR DIOXIDE (UG/M**3)
TRAILER NO. - 33 PERIOD(1/ 1/80 TO 1/31/80)

DAY	HOUR																								MEAN	
	1	2	3	4	5	6	7	8	9	10	11	12	13	14	15	16	17	18	19	20	21	22	23	24		
1	0	0	0	0	:	0	0	0	0	5	0	0	0	0	0	0	0	0	0	0	0	0	0	0	0	
2	0	0	0	0	:	0	0	0	0	0	0	0	0	0	0	0	0	0	0	0	0	0	0	0	0	
3	0	0	0	0	:	0	0	0	0	0	0	0	0	0	0	0	0	0	0	0	0	0	0	0	0	
4	0	0	0	0	:	0	0	0	0	0	0	0	0	0	0	0	0	0	0	0	0	0	0	0	0	
5	0	0	0	0	:	0	0	0	0	0	0	0	0	0	0	0	0	0	0	0	0	0	0	0	0	
6	0	0			:		0	0	0		0	0	0	0	0	0	0	0	0	0	0	0	0	0	0	
7	0	0	0	0	:	0	0	0	0	0	0	0	0	0	0	0	0	10	81	23	0	0	0	0	5	
8	0	0	0	0	:	0	0	0	0	0	0	3	5	0	0	0	0	5	34	13	0	0	0	0	3	
9	0	0	0	0	:	0	57	26	0	0	0	0	0	0	0	0	0	0	0	0	0	3	39	3	6	
10	0	0	0	0	:	0	0	0	0	0	0	0	0	0	0	0	0	0	0	0	0	0	0	0	0	
11	0	0	0	0	:	0	0	0	0	0	0	0	0	0	0	0	0	0	0	0	0	0	0	0	0	
12	0	0	0	0	:	0	0	0	0	0	0	0	0	0	0	0	0	0	0	0	0	0	0	0	0	
13	0	0	0	0	:	0	0	0	0	0	0	0	0	0	0	0	0	0	0	0	0	0	0	0	0	
14	0	0	0	0	:	0	0	0	0	0	0	0	0	0	0	0	0	0	0	0	0	0	0	0	0	
15	0	0	0	0	:	0	0	0	0	0	0	0	0	0	0	0	0	0	0	0	0	0	0	0	0	
16	0	0	0	0	:	0	0	0	0	0	0	0	0	0	0	0	0	0	0	0	0	0	0	0	0	
17	0	0	0	0	:	0	0	0	0	0	0	0	0	0	0	0	0	0	0	0	0	0	0	0	0	
18	0	0	0	0	:	0	0	0	0	0	5	0	0	0	0	8	0	0	0	0	0	0	0	0	0	1
19	0	0	0	0	:	0	0	0	0	0	0	0	0	0	0	0	0	0	0	0	0	0	0	0	0	
20	0	0	0	0	:	0	0	0	0	0	0	0	0	0	0	0	0	0	0	0	0	0	0	0	0	
21	0	0	0	0	:	0	0	0	0	0	0	0	0	0	0	0	0	0	0	0	0	0	0	0	0	
22	0	0	0	0	:	0	0	0	0	0	:	:	0	0	0	0	0	0	0	0	0	0	0	0	0	
23	0	0	0	0	:	0	0	0	0	0	0	0	0	0	0	0	0	0	0	0	0	0	0	0	0	
24	0	0	0	0	:	0	0	0	0	0	0	0	0	0	0	0	0	0	0	0	0	0	0	0	0	
25	0	0	0	0	:	0	0	0	0	0	0	0	0	0	0	0	0	0	0	0	0	0	0	0	0	
26	0	0	0	0	:	0	0	0	0	0	0	0	26	0	0	0	0	0	0	0	0	0	0	0	1	
27	0	0	0	0	:	0	0	0	0	0	0	0	0	0	0	0	0	0	0	0	0	0	0	0	0	
28	0	0	0	0	:	0	0	0	0	0	0	0	0	0	0	0	0	0	0	0	0	0	0	0	0	
29	0	0	0	0	:	0	0	0	0	0	0	0	0	0	0	0	0	0	0	0	0	0	0	0	0	
30	0	0	0	0	:	0	0	0	0	0	0	0	0	0	0	0	0	0	0	0	0	0	0	0	0	
31	0	0	0	0	:	0	0	0	0	0	0	0	0	0	0	0	0	0	0	0	0	0	0	0	0	
MEAN	0	0	0	0	:	0	2	1	0	0	0	0	1	0	0	0	0	0	4	1	0	0	1	0	0	

TOTAL NUMBER OF OBSERVATIONS = 706 MEAN = 0.5
: INDICATES CALIBRATION FOR THE HOUR

TABLE 5. HOURLY AVERAGES OF HYDROGEN SULFIDE (UG/M**3) (cont.)
 TRAILER NO. - 33 PERIOD(1/ 1/80 TO 1/31/80)

DAY	HOUR																								MEAN
	1	2	3	4	5	6	7	8	9	10	11	12	13	14	15	16	17	18	19	20	21	22	23	24	
1	0	0	0	0	:	0	0	0	0	0	0	0	0	0	0	0	0	0	0	0	0	0	0	0	0
2	0	0	0	0	:	0	0	0	0	0	0	0	0	0	0	0	0	0	0	0	0	0	0	0	0
3	0	0	0	0	:	0	0	0	0	0	0	0	0	0	0	0	0	0	0	0	0	0	0	0	0
4	0	0	0	0	:	0	0	0	0	0	0	0	0	0	0	0	0	0	0	0	0	0	0	0	0
5	0	0	0	0	:	0	0	0	0	0	0	0	0	0	0	0	0	0	0	0	0	0	0	0	0
6	0	0	0	0	:	0	0	0	0	0	0	0	0	0	0	0	0	0	0	0	0	0	0	0	0
7	0	0	0	0	:	0	0	0	0	0	0	0	0	0	0	0	0	0	0	0	0	0	0	0	0
8	0	0	0	0	:	0	0	0	0	0	0	0	0	0	0	0	0	0	0	0	0	0	0	0	0
9	0	0	0	0	:	0	0	0	0	0	0	0	0	0	0	0	0	0	0	0	0	0	0	0	0
10	0	0	0	0	:	0	0	0	0	0	0	0	0	0	0	0	0	0	0	0	0	0	0	0	0
11	0	0	0	0	:	0	0	0	0	0	0	0	0	0	0	0	0	0	0	0	0	0	0	0	0
12	0	0	0	0	:	0	0	0	0	0	0	0	0	0	0	0	0	0	0	0	0	0	0	0	0
13	0	0	0	0	:	0	0	0	0	0	0	0	0	0	0	0	0	0	0	0	0	0	0	0	0
14	0	0	0	0	:	0	0	0	0	0	0	0	0	0	0	0	0	0	0	0	0	0	0	0	0
15	0	0	0	0	:	0	0	0	0	0	0	0	0	0	0	0	0	0	0	0	0	0	0	0	0
16	0	0	0	0	:	0	0	0	0	0	0	0	0	0	0	0	0	0	0	0	0	0	0	0	0
17	0	0	0	0	:	0	0	0	0	0	0	0	0	0	0	0	0	0	0	0	0	0	0	0	0
18	0	0	0	0	:	0	0	0	0	0	0	0	0	0	0	0	0	0	0	0	0	0	0	0	0
19	0	0	0	0	:	0	0	0	0	0	0	0	0	0	0	0	0	0	0	0	0	0	0	0	0
20	0	0	0	0	:	0	0	0	0	0	0	0	0	0	0	0	0	0	0	0	0	0	0	0	0
21	0	0	0	0	:	0	0	0	0	0	0	0	0	0	0	0	0	0	0	0	0	0	0	0	0
22	0	0	0	0	:	0	0	0	0	0	0	0	3	0	0	0	0	0	0	0	0	0	0	0	0
23	0	0	0	0	:	0	0	0	0	0	0	0	0	0	0	0	0	0	0	0	0	0	0	0	0
24	0	0	0	0	:	0	0	0	0	0	0	0	0	0	0	0	0	0	0	0	0	0	0	0	0
25	0	0	0	0	:	0	0	0	0	0	0	0	0	0	0	0	0	0	0	0	0	0	0	0	0
26	0	0	0	0	:	0	0	0	0	0	0	0	0	0	0	0	0	0	0	0	0	0	0	0	0
27	0	0	0	0	:	0	0	0	0	0	0	0	0	0	0	0	0	0	0	0	0	0	0	0	0
28	0	0	0	0	:	0	0	0	0	0	0	0	0	0	0	0	0	0	0	0	0	0	0	0	0
29	0	0	0	0	:	0	0	0	0	0	0	0	0	0	0	0	0	0	0	0	0	0	0	0	0
30	0	0	0	0	:	0	0	0	0	0	0	0	0	0	0	0	0	0	0	0	0	0	0	0	0
31	0	0	0	0	:	0	0	0	0	0	0	0	0	0	0	0	0	0	0	0	0	0	0	0	0
MEAN	0	0	0	0	:	0	0	0	0	0	0	0	0	0	0	0	0	0	0	0	0	0	0	0	0

TOTAL NUMBER OF OBSERVATIONS = 709 MEAN = 0.0
 : INDICATES CALIBRATION FOR THE HOUR

TABLE 5. HOURLY AVERAGES OF METHANE ((UG/M**3)X10**-1) (cont.)
TRAILER NO. - 33 PERIOD (1/ 1/80 TO 1/31/80)

DAY	HOUR																								MEAN
	1	2	3	4	5	6	7	8	9	10	11	12	13	14	15	16	17	18	19	20	21	22	23	24	
1	140	147	143	135	:	147	157	175	193	144	124	116	116	115	114	115	116	117	118	115	118	119	117	120	131
2	134	124	115	112	:	121	118	138	126	121	113	106	107	107	107	106	106	113	112	109	106	106	109	110	114
3	114	111	106	104	:	105	114	123	127	128	123	123	126	126	123	121	119	118	119	116	115	118	117	122	118
4	119	118	120	124	:	120	123	130	131	130	126	124	125	121	118	117	115	120	120	124	122	121	120	120	122
5	120	120	121	121	:	192	187	149	168	145	127	117	127	131	121	114	113	112	112	115	112	116	116	120	129
6	119	109					109	109	100	102	103	102	103	102	102	102	102	101	101	102	103	109	106	104	105
7	106	106	105	105	:	107	105	107	108	119	118	120	122	124	128	124	122	132	138	129	115	114	117	126	117
8	135	140	163	131	:	132	135	136	129	127	127	128	128	125	122	120	118	141	148	139	124	119	119	118	131
9	141	172	163	160	:	195	172	135	129	124	120	119	117	121	122	123	122	121	126	127	136	129	123	118	135
10	116	117	117	117	:	146	136	127	127	125	134	131	130	123	127	127	119	113	107	102	97	97	97	98	119
11	101	99	100	100	:	103	104	109	114	113	112	111	110	109	112	108	110	116	122	120	116	119	128	125	111
12	129	117	109	110	:	109	107	107	106	108	108	109	109	107	106	109	111	112	112	111	114	112	112	113	111
13	114	112	112	112	:	112	112	109	108	110	111	108	106	108	110	108	108	109	108	108	111	115	109	106	110
14	105	107	108	108	:	108	109	117	124	104	113	111	109	107	105	105	109	115	119	114	115	112	119	125	112
15	120	116	111	121	:	120	123	122	128	119	114	114	114	112	114	113	112	113	111	113	115	115	120	122	117
16	124	128	135	139	:	146	127	118	118	117	112	108	104	102	108	104	104	105	106	104	101	105	123	121	116
17	114	109	101	101	:	130	130	137	143	140	128	126	116	107	116	109	118	116	127	121	121	132	184	188	127
18	188	192	202	192	:	285	257	229	199	139	136	118	112	114	115	113	118	127	116	115	118	118	116	117	154
19	112	115	115	117	:	119	118	116	115	115	117	117	115	114	118	126	127	124	123	123	128	125	120	116	119
20	121	126	123	124	:	124	129	122	122	124	121	117	119	134	110	109	98	100	97	102	100	97	103	106	114
21	111	111	105	106	:	102	102	103	100	105	110	106	95	94	93	93	95	98	96	104	101	113	113	101	102
22	98	95	93	93	:	94	93	96	121	127		128	121	118	120	119	116	118	114	112	109	113	113	111	110
23	112	113	112	111	:	111	110	111	111	112	114	114	112	110	109	108	110	110	111	115	114	120	119	125	113
24	126	123	124	119	:	123	122	133	154	146	128	120	111	112	111	108	108	109	109	110	110	112	112	111	119
25	109	109	108	107	:	108	112	113	120	122	123	121	117	112	110	110	110	112	111	112	114	114	113	113	113
26	114	117	123	118	:	134	125	138	152	197	201	224	179	169	158	144	132	126	122	132	126	127	139	162	146
27	163	176	142	140	:	144	131	134	126	125	119	120	128	132	131	128	122	119	119	121	130	128	121	125	131
28	132	134	167	157	:	138	124	124	123	138	122	120	118	120	118	115	119	117	118	121	128	121	121	124	127
29	121	120	123	123	:	157	154	161	162	152	150	145	145	139	136	133	130	130	132	131	132	132	134	131	138
30	135	130	143	133	:	135	127	143	145	153	159	161	117	105	104	105	108	107	149	127	128	131	133	136	131
31	132	128	129	125	:	124	123	121	118	118	120	120	121	121	120	121	123	121	119	120	119	122	122	123	122
MEAN	123	124	125	122		133	130	129	131	127	124	123	119	117	116	115	114	116	117	117	116	117	120	121	

TOTAL NUMBER OF OBSERVATIONS = 708 MEAN = 121.5
: INDICATES CALIBRATION FOR THE HOUR

VI. FEBRUARY METHANE BAG SAMPLING PROGRAM

Grab-bag samples are collected bi-weekly and analyzed for methane. The ambient air samples are collected in tedlar bags using a metal bellows pump connected to the ambient sample manifold. Each bag sample is collected over a three-hour period.

The bag samples are returned to Austin for analysis for methane concentration. The analysis is performed on either a Bendix 8202 or a Baseline Industries Model 1030 gas chromatograph using a flame ionization detector. The minimum detectable limit using this technique is less than 1 ppm.

Results of the bag sampling analyses are given below:

<u>Date</u>	<u>Time</u>	<u>Methane Concentration (ppm)</u>
2/5/80	0600-0900	6.51
2/19/80	0600-0900	1.83

TABLE 6.
DOWNTIME HOURS FOR CHOCOLATE BAYOU, TEXAS, 1980
(FEBRUARY)

SITE 033 DIGITIZING					
DATE	SYSTEM	SO2	H2S	CH4	TSP
2/ 1	0	0	0	0	-
2/ 2	0	0	0	0	-
2/ 3	0	0	0	0	0
2/ 4	0	0	0	0	-
2/ 5	0	0	1	0	-
2/ 6	0	0	0	0	0
2/ 7	0	0	0	0	-
2/ 8	1	0	0	0	-
2/ 9	0	0	0	0	0
2/10	0	0	0	0	-
2/11	0	0	0	0	-
2/12	0	0	0	0	0
2/13	0	0	0	0	-
2/14	0	0	0	0	-
2/15	20	0	0	0	24
2/16	24	0	0	0	-
2/17	24	0	0	0	-
2/18	12	0	0	0	-
2/19	0	0	0	0	0
2/20	0	0	0	0	-
2/21	0	0	0	0	0
2/22	0	0	0	0	-
2/23	0	0	0	0	-
2/24	0	0	0	0	0
2/25	0	0	0	0	-
2/26	0	0	0	0	-
2/27	0	0	0	0	0
2/28	0	0	0	0	-
2/29	0	0	1	0	-
CAL TIME		27	26	28	
DATA CAPTURE RATE (%)		88	88	88	89

Downtime Summary for February 1980

Downtime during the month was caused by a faulty power supply in the data acquisition system which failed on February 15. A new power supply was installed on the 18th and no further downtime occurred during the month.

TABLE 7
FEDERAL AND TEXAS STATE AMBIENT AIR QUALITY STANDARDS (FEBRUARY)

Agency	Pollutant	Special Conditions		$\mu\text{g}/\text{m}^3$ Primary	(PPM)	$\mu\text{g}/\text{m}^3$ Secondary	(PPM)
Federal and Texas	SO ₂		Annual	80	.03		
			24-Hour*	365	.14		
			3-Hour*	---		1300	.5
Texas	SO ₂	All Counties Except Harris, Galveston Orange, Jefferson	30-Minute**	1061	.4	----	
			30-Minute**	743	.28	----	
			30-Minute**	849	.32	----	
Federal and Texas	Particulate		Annual***	75		60	
			24-Hour*	260		150	
Texas	Particulate		5-Hour**	100		---	
			3-Hour**	200		---	
			1-Hour**	400		---	
Federal and Texas	CO		8-Hour*	10,000	9.	10,000	9.
			1-Hour*	40,000	35.	40,000	35.
Federal and Texas	Photochemical Oxidant HC (Non-Methane) NO ₂	6-9 a.m.	1-Hour†	235	.12	235	.12
			3-Hour*	160	.24	160	.24
			Annual	100	.05	100	.05

*Not to be exceeded more than once per year.

**Texas special regulations. Single plant source may not exceed these ambient levels in Texas at any point, at any time.

***Geometric Mean.

†The expected number of exceedances not to occur on more than one calendar day per year.

TABLE 8. DAILY AVERAGES FOR FEB 1 1980 THRU FEB 29 1980

SITE DATE	SULFUR DIOXIDE (UG/M**3)	HYDROGEN SULFIDE (UG/M**3)	METHANE ((UG/M**3) X 10**-1)
	033	033	033
FEB 01	0.0	0.0	121.3
FEB 02	0.0	0.0	139.4
FEB 03	0.0	0.0	141.6
FEB 04	0.0	0.0	140.4
FEB 05	0.0	0.0	129.6
FEB 06	2.3	0.0	168.0
FEB 07	0.0	0.0	143.4
FEB 08	0.0	0.0	120.3
FEB 09	0.0	0.0	118.1
FEB 10	0.0	0.0	120.0
FEB 11	0.0	0.0	128.9
FEB 12	0.0	0.0	141.0
FEB 13	0.0	0.0	124.6
FEB 14	0.0	0.0	131.3
FEB 15			
FEB 16			
FEB 17			
FEB 18	0.0	0.1	110.8
FEB 19	0.0	0.0	105.1
FEB 20	0.0	0.0	99.4
FEB 21	0.0	0.0	106.5
FEB 22	0.0	0.0	114.0
FEB 23	0.0	0.0	111.5
FEB 24	0.0	0.0	121.9
FEB 25	0.0	0.0	118.3
FEB 26	1.1	0.0	112.5
FEB 27	0.0	0.0	112.8
FEB 28	0.0	0.0	99.4
FEB 29	0.0	0.0	95.4
FEB 01 -29	0.1	0.0	122.5

TABLE 8. DAILY AVERAGES FOR FEB 1 1980 THRU FEB 29 1980 (cont.)

TOTAL SUSPENDED PARTICULATE (UG/M**3)

SITE	033
DATE	
FEB 01	
FEB 02	
FEB 03	40.0
FEB 04	
FEB 05	
FEB 06	40.0
FEB 07	
FEB 08	
FEB 09	26.0
FEB 10	
FEB 11	
FEB 12	27.0
FEB 13	
FEB 14	
FEB 15	
FEB 16	
FEB 17	
FEB 18	
FEB 19	23.0
FEB 20	
FEB 21	37.0
FEB 22	
FEB 23	
FEB 24	44.0
FEB 25	
FEB 26	
FEB 27	38.0
FEB 28	
FEB 29	
FEB 01 -29	33.5

TABLE 9. THE FIVE MAXIMUM INDEPENDENT SLIDING AVERAGES FOR FEB 1, 1980 - FEB 29, 1980

SULFUR DIOXIDE (UG/M**3)
3-HOUR

SITE 033

1.	2/ 6(0:00- 3:00)	17.3
2.	2/26(16:00-19:00)	8.6
3.	2/ 1(9:00-12:00)	0.0
4.	2/ 1(12:00-15:00)	0.0
5.	2/ 1(15:00-18:00)	0.0

SULFUR DIOXIDE (UG/M**3)
24-HOUR

SITE 033

1.	2/ 5(3:00- 3:00)	2.1
2.	2/25(19:00-19:00)	1.1
3.	2/ 2(0:00- 0:00)	0.0
4.	2/ 3(0:00- 0:00)	0.0
5.	2/ 4(0:00- 0:00)	0.0

TOTAL SUSPENDED PARTICULATE (UG/M**3)
24-HOUR

SITE 033

1.	2/24(0:00- 0:00)	44.0
2.	2/ 6(0:00- 0:00)	40.0
3.	2/ 3(0:00- 0:00)	40.0
4.	2/27(0:00- 0:00)	38.0
5.	2/21(0:00- 0:00)	37.0

TABLE 9. THE FIVE MAXIMUM INDEPENDENT SLIDING AVERAGES FOR FEB 1, 1980 - FEB 29, 1980
(cont.)

HYDROGEN SULFIDE (UG/M**3)
1-HOUR

SITE 033

1.	2/18(12:00-13:00)	1.0
2.	2/26(18:00-19:00)	1.0
3.	2/ 1(2:00- 3:00)	0.0
4.	2/ 1(3:00- 4:00)	0.0
5.	2/ 1(1:00- 2:00)	0.0

METHANE ((UG/M**3) X 10**-1)
6-9 AM

SITE 033

1.	2/ 6(6:00- 9:00)	241.6
2.	2/12(6:00- 9:00)	169.6
3.	2/ 4(6:00- 9:00)	166.6
4.	2/ 5(6:00- 9:00)	158.6
5.	2/ 3(6:00- 9:00)	158.0

SULFUR DIOXIDE (UG/M**3)
1-HOUR

SITE 033

1.	2/ 6(1:00- 2:00)	42.0
2.	2/26(18:00-19:00)	26.0
3.	2/ 6(2:00- 3:00)	10.0
4.	2/ 1(3:00- 4:00)	0.0
5.	2/ 1(2:00- 3:00)	0.0

TABLE 10. HOURLY AVERAGES OF SULFUR DIOXIDE (UG/M**3)
TRAILER NO. - 33 PERIOD(2/ 1/80 TO 2/29/80)

DAY	HOUR																								MEAN
	1	2	3	4	5	6	7	8	9	10	11	12	13	14	15	16	17	18	19	20	21	22	23	24	
1	0	0	0	0	:	0	0	0	0	0	0	0	0	0	0	0	0	0	0	0	0	0	0	0	0
2	0	0	0	0	:	0	0	0	0	0	0	0	0	0	0	0	0	0	0	0	0	0	0	0	0
3	0	0	0	0	:	0	0	0	0	0	0	0	0	0	0	0	0	0	0	0	0	0	0	0	0
4	0	0	0	0	:	0	0	0	0	0	0	0	0	0	0	0	0	0	0	0	0	0	0	0	0
5	0	0	0	0	:	0	0	0	0	0	0	0	0	0	0	0	0	0	0	0	0	0	0	0	0
6	0	42	10	0	:	0	0	0	0	0	0	0	0	0	0	0	0	0	0	0	0	0	0	0	2
7	0	0	0	0	:	0	0	0	0	0	0	0	0	0	0	0	0	0	0	0	0	0	0	0	0
8	0	0	0	0	:	0	0	0	0	0	0	0	0	0	0	0	0	0	0	0	0	0	0	0	0
9	0	0	0	0	:	0	0	0	0	0	0	0	0	0	0	0	0	0	0	0	0	0	0	0	0
10	0	0	0	0	:	0	0	0	0	0	0	0	0	0	0	0	0	0	0	0	0	0	0	0	0
11	0	0	0	0	:	0	0	0	0	0	0	0	0	0	0	0	0	0	0	0	0	0	0	0	0
12	0	0	0	0	:	0	0	0	0	0	0	0	0	0	0	0	0	0	0	0	0	0	0	0	0
13	0	0	0	0	:	0	0	0	0	0	0	0	0	0	0	0	0	0	0	0	0	0	0	0	0
14	0	0	0	0	:	0	0	0	0	0	0	0	0	0	0	0	0	0	0	0	0	0	0	0	0
15	0	0	0	0	:	0	0	0	0	0	0	0	0	0	0	0	0	0	0	0	0	0	0	0	0
16																									
17																									
18												0	0	0	0	0	0	0	0	0	0	0	0	0	0
19	0	0	0	0	:	0	0	0	0	0	0	0	0	0	0	0	0	0	0	0	0	0	0	0	0
20	0	0	0	0	:	0	0	0	0	0	0	0	0	0	0	0	0	0	0	0	0	0	0	0	0
21	0	0	0	0	:	0	0	0	0	:	0	0	0	0	0	0	0	0	0	0	0	0	0	0	0
22	0	0	0	0	:	0	0	0	0	0	0	0	0	0	0	0	0	0	0	0	0	0	0	0	0
23	0	0	0	0	:	0	0	0	0	0	0	0	0	0	0	0	0	0	0	0	0	0	0	0	0
24	0	0	0	0	:	0	0	0	0	0	0	0	0	0	0	0	0	0	0	0	0	0	0	0	0
25	0	0	0	0	:	0	0	0	0	0	0	:	0	0	0	0	0	0	0	0	0	0	0	0	0
26	0	0	0	0	:	0	0	0	0	0	0	0	0	0	0	0	0	0	26	0	0	0	0	0	1
27	0	0	0	0	:	0	0	0	0	0	0	0	0	0	0	0	0	0	0	0	0	0	0	0	0
28	0	0	0	0	:	0	0	0	0	0	0	0	0	0	0	0	0	0	0	0	0	0	0	0	0
29	0	0	0	0	:	0	0	0	0	0	0	0	0	0	0	0	0	0	0	0	0	0	0	0	0
MEAN	0	2	0	0		0	0	0	0	0	0	0	0	0	0	0	0	0	1	0	0	0	0	0	0

TOTAL NUMBER OF OBSERVATIONS = 588 MEAN = 0.1
: INDICATES CALIBRATION FOR THE HOUR

CORPORATION

8

TABLE 10. HOURLY AVERAGES OF HYDROGEN SULFIDE (UG/M**3) (cont.)
TRAILER NO. - 33 PERIOD(2/ 1/80 TO 2/29/80)

DAY	HOUR																								
	1	2	3	4	5	6	7	8	9	10	11	12	13	14	15	16	17	18	19	20	21	22	23	24	MEAN
1	0	0	0	0	:	0	0	0	0	0	0	0	0	0	0	0	0	0	0	0	0	0	0	0	0
2	0	0	0	0	:	0	0	0	0	0	0	0	0	0	0	0	0	0	0	0	0	0	0	0	0
3	0	0	0	0	:	0	0	0	0	0	0	0	0	0	0	0	0	0	0	0	0	0	0	0	0
4	0	0	0	0	:	0	0	0	0	0	0	0	0	0	0	0	0	0	0	0	0	0	0	0	0
5	0	0	0	0	:	0	0	0	0	0	0	0	0	0	0	0	0	0	0	0	0	0	0	0	0
6	0	0	0	0	:	0	0	0	0	0	0	0	0	0	0	0	0	0	0	0	0	0	0	0	0
7	0	0	0	0	:	0	0	0	0	0	0	0	0	0	0	0	0	0	0	0	0	0	0	0	0
8	0	0	0	0	:	0	0	0	0	0	0	0	0	0	0	0	0	0	0	0	0	0	0	0	0
9	0	0	0	0	:	0	0	0	0	0	0	0	0	0	0	0	0	0	0	0	0	0	0	0	0
10	0	0	0	0	:	0	0	0	0	0	0	0	0	0	0	0	0	0	0	0	0	0	0	0	0
11	0	0	0	0	:	0	0	0	0	0	0	0	0	0	0	0	0	0	0	0	0	0	0	0	0
12	0	0	0	0	:	0	0	0	0	0	0	0	0	0	0	0	0	0	0	0	0	0	0	0	0
13	0	0	0	0	:	0	0	0	0	0	0	0	0	0	0	0	0	0	0	0	0	0	0	0	0
14	0	0	0	0	:	0	0	0	0	0	0	0	0	0	0	0	0	0	0	0	0	0	0	0	0
15	0	0	0	0	:	0	0	0	0	0	0	0	0	0	0	0	0	0	0	0	0	0	0	0	0
16																									
17																									
18												1	0	0	0	0	0	0	0	0	0	0	0	0	0
19	0	0	0	0	:	0	0	0	0	0	0	0	0	0	0	0	0	0	0	0	0	0	0	0	0
20	0	0	0	0	:	0	0	0	0	0	0	0	0	0	0	0	0	0	0	0	0	0	0	0	0
21	0	0	0	0	:	0	0	0	0	:	0	0	0	0	0	0	0	0	0	0	0	0	0	0	0
22	0	0	0	0	:	0	0	0	0	0	0	0	0	0	0	0	0	0	0	0	0	0	0	0	0
23	0	0	0	0	:	0	0	0	0	0	0	0	0	0	0	0	0	0	0	0	0	0	0	0	0
24	0	0	0	0	:	0	0	0	0	0	0	0	0	0	0	0	0	0	0	0	0	0	0	0	0
25	0	0	0	0	:	0	0	0	0	0	0	0	0	0	0	0	0	0	0	0	0	0	0	0	0
26	0	0	0	0	:	0	0	0	0	0	0	0	0	0	0	0	0	0	1	0	0	0	0	0	0
27	0	0	0	0	:	0	0	0	0	0	0	0	0	0	0	0	0	0	0	0	0	0	0	0	0
28	0	0	0	0	:	0	0	0	0	0	0	0	0	0	0	0	0	0	0	0	0	0	0	0	0
29	0	0	0	0	:	0	0	0	0	0	0	0	0	0	0	0	0	0	0	0	0	0	0	0	0
MEAN	0	0	0	0		0	0	0	0	0	0	0	0	0	0	0	0	0	0	0	0	0	0	0	0

TOTAL NUMBER OF OBSERVATIONS = 587 MEAN = 0.0
: INDICATES CALIBRATION FOR THE HOUR

TABLE 10. HOURLY AVERAGES OF METHANE((UG/M**3) X 10**-1) (cont.)
TRAILER NO. - 33 PERIOD(2/ 1/80 TO 2/29/80)

DAY	HOUR																								MEAN	
	1	2	3	4	5	6	7	8	9	10	11	12	13	14	15	16	17	18	19	20	21	22	23	24		
1	125	122	120	119	:	119	118	118	117	115	116	115	115	116	114	115	122	133	153	132	120	123	122	122	121	
2	121	168	254	187	:	138	135	133	127	136	138	123	121	125	127	128	130	128	135	130	132	134	130	127	139	
3	133	140	185	168	:	156	161	155	158	154	144	135	127	131	124	120	123	125	131	130	132	137	135	153	142	
4	178	167	155	149	:	161	154	178	168	222	142	137	120	121	118	114	113	114	124	129	126	114	113	113	140	
5	112	127	118	118	:	124	149	173	154	126	126	111	107	107	107	121	130	139	138	133	130	132	149	150	130	
6	220	309	287	273	:	199	254	240	231	190	154	124	118	119	119	118	119	112	110	111	110	109	116	121	168	
7	128	122	119	205	:	130	194	127	115	146	127	126	132	139	195	128	129	112	111	116	122	115	191	269	143	
8	303	154	113		:	106	103	103	102	101	101	101	101	101	101	101	101	102	126	123	124	123	130	126	120	
9	127	124	123	123	:	128	123	126	120	118	116	116	116	114	112	111	113	113	114	114	116	117	117	116	118	
10	116	117	118	116	:	115	115	116	116	116	115	116	117	119	122	120	117	120	127	129	131	138	122	123	120	
11	128	126	128	129	:	166	122	129	144	140	137	145	126	118	122	121	121	123	118	120	128	121	123	129	129	
12	168	176	171	174	:	245	210	163	136	133	125	120	119	121	121	120	121	116	117	117	116	119	118	116	141	
13	120	122	122	131	:	132	128	126	130	135	130	120	109	110	112	112	116	122	131	132	130	130	132	133	125	
14	132	126	117	124	:	169	135	120	128	134	139	133	133	128	126	127	129	128	127	130	131	128	133	144	131	
15	139	131	125	126																					130	
16																										
17																										
18														112	113	116	115	109	108	107	109	111	113	111	106	111
19	108	109	124	107	:	104	103	107	116	104	102	102	102	102	102	101	101	102	103	102	104	104	106	103	105	
20	102	102	101	101	:	101	101	100	99	98	98	98	99	128	95	96	95	97	97	95	97	95	97	96	96	99
21	96	96	93	96	:	100	99	101	107	:			110	112	112	112	110	110	108	109	109	110	114	114	118	106
22	109	111	117	116	:	118	118	112	108	108	115	124	120	120	120	120	118	108	109	109	106	109	110	118	114	
23	125	116	106	108	:	103	108	108	114	112	112	112	111	106	107	108	110	110	111	110	116	117	117	118	112	
24	122	126	128	127	:	131	133	143	140	126	129	123	113	108	109	109	112	114	113	116	116	118	123	124	122	
25	121	121	122	113	:	118	130	140	127	118	123	127	120	116	111	108	107	108	113	117	116	120	109	117	118	
26	147	123	113	114	:	115	113	112	114	108	112	115	109	108	111	108	105	107	124	106	106	105	105	108	113	
27	112	111	108	114	:	156	131	135	150	132	107	103	103	103	102	101	100	101	101	103	103	104	103	111	113	
28	123	125	114	107	:	107	108	108	110	106	95	94	94	93	93	92	91	90	91	93	90	89	87	87	99	
29	86	86	85	87	:	84	84	83	82	:	99	101	101	101	101	101	101	101	101	101	102	102	103	105	95	
MEAN	135	133	133	133		133	133	130	129	129	121	117	115	113	115	112	113	113	117	116	116	117	120	125		

TOTAL NUMBER OF OBSERVATIONS = 587 MEAN = 122.5
: INDICATES CALIBRATION FOR THE HOUR

VII. DESCRIPTION OF INSTRUMENT SYSTEMS (MARCH-OCTOBER)

The ambient air monitoring station is equipped to monitor the parameters shown below:

Sulfur Dioxide
Particulates
Methane
Hydrogen Sulfide

A. Air Quality Instrumentation

1. Description

Sulfur dioxide is measured with a Meloy Model SA185-2A sulfur analyzer, which is an EPA-approved analyzer. This automated analyzer utilizes the flame photometric principle to measure sulfur levels with a minimum detectable sensitivity of 5 ppb, and a linearity of $\pm 1\%$. The analyzer is operated with an H₂S scrubber to make it specific to SO₂ concentrations.

Hydrogen sulfide is measured using a Meloy Model SA185-2 analyzer equipped with an SO_x scrubber. Specifications for this analyzer are the same as for the SA185-2A.

Methane is monitored with a Bendix Model 8200 gas chromatograph. This instrument uses a flame ionization detector and has a minimum detectable sensitivity of 5 ppb. The Model 8200 works on a five-minute cycle, i.e., one air sample is analyzed every five minutes.

The air sample is drawn in through a glass cane and manifold supplied by the Ace Glass Company. The system has a 25 mm diameter, and a constant air flow through the system is

provided by an air pump rated at 60 cfm at 0" head pressure. The manifold has sampling ports to which $\frac{1}{4}$ " Teflon lines to the instruments are connected. All joints in the sampling system are secured by O-ring compression fittings. The manifold is contained in a heated (100°F) chamber to prevent condensation of moisture.

The trailer has two heavy duty high volume particulate samplers (Hi-Vols). Fiberglass filter paper is brought to a controlled humidity before weighing. Each Hi-Vol has a flow recorder to permit correction for changes in air flow runs for a 24-hour period (midnight to midnight), and is turned on and off by the computer. The Hi-Vols were designed following guidelines recommended by the Environmental Protection Agency and were manufactured by Radian.

2. Calibration

The trailer contains a Meloy Model RAD-1 calibration unit. This unit provides a zero air supply and SO₂ span gas from an SO₂ permeation tube. The calibration is automatically performed once a day, and is controlled by the computer. The SO₂ channel is first switched to zero. Then the computer monitors the output of each analyzer and takes a new zero reading after a stable zero signal has been reached. This zero reading is compared by the computer to the zero reading obtained 24 hours before, and if a drift in excess of 10 ppb has occurred, an excess zero drift light on the System Status Panel is turned on. The instruments are then returned to the monitor mode, and after two minutes the computer resumes data taking.

The SO₂ permeation tubes were manufactured by Metronics Association, Inc. These tubes were then individually calibrated for Radian by the National Bureau of Standards.

The Model 8200 methane analyzer is calibrated with undiluted span gas. This span gas contains methane in air. The Model 8200 is zeroed with air from a Bendix Model 8834 zero air unit. In addition, the instrument is electronically re-zeroed at the start of every five-minute cycle.

In addition to the daily instrument zero/spans, all instruments are multipoint calibrated monthly. Calibration standards and equipment used in the monthly multipoints is distinct from the equipment used for daily zero/span operations.

Quality assurance audits are performed on each instrument once a quarter. These audits are performed by Radian's Quality Assurance personnel using instrumentation and standards different from those used in the monthly multipoint calibrations.

A General Metals Calibration Kit is used to calibrate the Hi-Vol particulate samplers.

B. Data Acquisition System

The station is equipped with a Radian DART II system. The DART II is designed around a Motorola M6800 microprocessor. The use of a microprocessor allows a variety of sophisticated data collection schemes with virtually no hardware expansion. Radian's standard system uses 32K (expandable to 65K) of semiconductor random access memory. A built-in floppy disk unit is used for program storage and loading. As a result, by simply changing the diskette an entirely different system configuration can be implemented. System parameters, such as sampling times, averaging times, input voltage ranges, printout formats, and recording techniques are under software control using the General Application Program (GAP) provided with each system.

The DART II system consists of an MPU (M6800) with 32K static RAM, auto-start ROM, serial interfaces, parallel interfaces, A/D converters with display, floppy disk, power supply, battery clock with display, on/off relay panel, terminal rear panel, cables, and rack mountable front panel.

Radian's standard data collection program generally is configured from key-ins to take one sample every second from each data channel and then use this data to form five-minute averages for each channel. These five-minute averages form the basis for further data reduction. On the hour, the microprocessor energizes the teleprinter through relay control, prints a hard-copy of the collected data, and records the data on floppy disk. Because the teleprinter and disk are mechanical devices, the microprocessor turns power off to them after each function is completed. This greatly enhances the lifetime of each.

1. Floppy Disk

The DART II system uses a floppy disk storage unit which stores both the program load software and data. The disk will store a total of 240,000 8-bit bytes. This allows for storage of averaged data for seven days. The program and data are recorded so that the diskettes will be IBM 3740-compatible. The controller issues an interrupt to the CPU after a disk read or write operation. A status register, readable by the CPU, indicates if there are any disk errors.

The disk space is organized into files containing a loader program, Radian's General Application Program (GAP) software, averaged data, operator log, calibration values, and system parameters, in addition to various report. The bootstrap loader program resides in Read Only Memory (ROM).

VIII. MARCH METHANE BAG SAMPLING PROGRAM

Grab-bag samples are collected bi-weekly and analyzed for methane. The ambient air samples are collected in tedlar bags using a metal bellows pump connected to the ambient sample manifold. Each bag sample is collected over a three-hour period.

The bag samples are returned to Austin for analysis for methane concentration. The analysis is performed on either a Bendix 8202 or a Baseline Industries Model 1030 gas chromatograph using a flame ionization detector. The minimum detectable limit using this technique is less than 1 ppm.

Results of the bag sampling analyses are given below:

<u>Date</u>	<u>Time</u>	<u>Methane Concentration (ppm)</u>
3/4/80	0600-0900	4.50
3/18/80	0600-0900	2.86

TABLE 11.
DOWNTIME HOURS FOR CHOCOLATE BAYOU, TEXAS, 1980
(MARCH)

SITE 033					
DIGITIZING					
DATE	SYSTEM	SO2	H2S	CH4	TSP
3/ 1	0	0	0	0	0
3/ 2	0	0	0	0	-
3/ 3	0	0	0	0	-
3/ 4	0	0	0	0	0
3/ 5	0	0	0	0	-
3/ 6	0	0	0	0	-
3/ 7	0	0	0	0	0
3/ 8	0	0	0	0	-
3/ 9	0	0	0	0	-
3/10	0	0	1	0	0
3/11	0	0	0	0	-
3/12	0	0	0	0	-
3/13	0	0	0	0	0
3/14	1	0	0	0	-
3/15	0	0	0	0	-
3/16	0	0	0	6	0
3/17	0	0	0	17	-
3/18	0	0	0	8	-
3/19	0	0	0	0	0
3/20	0	0	0	15	-
3/21	0	0	1	8	-
3/22	0	0	0	0	0
3/23	0	0	0	0	-
3/24	0	0	0	0	-
3/25	0	0	0	0	0
3/26	0	0	0	0	-
3/27	0	0	0	0	-
3/28	0	0	0	0	0
3/29	14	0	0	0	-
3/30	24	0	0	0	-
3/31	24	0	0	0	0
CAL TIME		32	31	29	
DATA CAPTURE RATE (%)		92	91	84	100

Downtime Summary for March 1980

The methane analyzer failed on the 17th. A new analyzer was installed on the 18th. A zero air source delivered with the new analyzer malfunctioned on the 20th, causing another day of data loss.

The system software went down on the 29th, resulting in two and one-half days of data loss at the end of the month.

TABLE 12.

FEDERAL AND TEXAS STATE AMBIENT AIR QUALITY STANDARDS (MARCH)

Agency	Pollutant	Special Conditions		$\mu\text{g}/\text{m}^3$ Primary	(PPM)	$\mu\text{g}/\text{m}^3$ Secondary	(PPM)	
Federal and Texas	SO ₂		Annual	80	.03			
			24-Hour*	365	.14			
			3-Hour*	---		1300	.5	
Texas	SO ₂	All Counties Except	30-Minute**	1061	.4	----		
			Harris, Galveston	30-Minute**	743	.28	----	
			Orange, Jefferson	30-Minute**	849	.32	----	
Federal and Texas	Particulate		Annual***	75		60		
			24-Hour*	260		150		
Texas	Particulate		5-Hour**	100		---		
			3-Hour**	200		---		
			1-Hour**	400		---		
Federal and Texas	CO		8-Hour*	10,000	9.	10,000	9.	
			1-Hour*	40,000	35.	40,000	35.	
Federal and Texas	Photochemical Oxidant HC (Non-Methane) NO ₂	6-9 a.m.	1-Hour†	235	.12	235	.12	
			3-Hour*	160	.24	160	.24	
			Annual	100	.05	100	.05	

*Not to be exceeded more than once per year.

**Texas special regulations. Single plant source may not exceed these ambient levels in Texas at any point, at any time.

***Geometric Mean.

†The expected number of exceedances not to occur on more than one calendar day per year.

TABLE 13. DAILY AVERAGES FOR MAR 1 1980 THRU MAR 31 1980

86

SITE DATE	SULFUR DIOXIDE (UG/M**3)	HYDROGEN SULFIDE (UG/M**3)	METHANE((UG/M**3)X10**-1)
	033	033	033
MAR 01	0.0	0.0	117.5
MAR 02	0.0	0.0	128.9
MAR 03	0.0	0.0	122.3
MAR 04	0.0	0.0	101.6
MAR 05	0.0	0.0	120.3
MAR 06	0.0	0.0	139.3
MAR 07	0.0	0.0	103.3
MAR 08	0.0	0.0	104.1
MAR 09	0.0	0.0	132.6
MAR 10	0.0	0.0	113.6
MAR 11			
MAR 12	0.0	0.0	103.2
MAR 13	0.0	0.0	121.2
MAR 14	0.0	0.0	128.3
MAR 15	0.0	0.0	128.3
MAR 16	0.0	0.0	96.5
MAR 17	0.0	0.0	
MAR 18	0.0	0.0	118.6
MAR 19	0.7	0.0	111.7
MAR 20	0.0	0.0	
MAR 21	0.0	0.0	111.3
MAR 22	0.0	0.0	125.8
MAR 23	0.0	0.0	103.6
MAR 24	0.0	0.0	116.4
MAR 25	0.0	0.0	121.2
MAR 26	0.0	0.0	118.7
MAR 27	0.0	0.0	117.3
MAR 28	1.8	0.3	120.5
MAR 29			
MAR 30			
MAR 31			
MAR 01 -31	0.1	0.0	116.4

TABLE 13. DAILY AVERAGES FOR MAR 1 1980 THRU MAR 31 1980 (cont.)

TOTAL SUSPENDED PARTICULATE (UG/M**3)

SITE	033
DATE	
MAR 01	37.0
MAR 02	
MAR 03	
MAR 04	37.0
MAR 05	
MAR 06	
MAR 07	32.0
MAR 08	
MAR 09	
MAR 10	33.0
MAR 11	
MAR 12	
MAR 13	113.0
MAR 14	
MAR 15	
MAR 16	42.0
MAR 17	
MAR 18	
MAR 19	35.0
MAR 20	
MAR 21	
MAR 22	38.0
MAR 23	
MAR 24	
MAR 25	45.0
MAR 26	
MAR 27	
MAR 28	34.0
MAR 29	
MAR 30	
MAR 31	48.0
MAR 01 -31	41.7

TABLE 14. THE FIVE MAXIMUM INDEPENDENT SLIDING AVERAGES FOR MAR 1, 1980 - MAR 31, 1980

HYDROGEN SULFIDE (UG/M**3)
1-HOUR

SITE 033

1.	3/21(15:00-16:00)	1.0
2.	3/28(12:00-13:00)	1.0
3.	3/28(13:00-14:00)	1.0
4.	3/28(14:00-15:00)	1.0
5.	3/28(15:00-16:00)	1.0

METHANE ((UG/M**3) X 10**-1)
6-9 AM

SITE 033

1.	3/ 3(6:00- 9:00)	176.3
2.	3/ 9(6:00- 9:00)	142.6
3.	3/28(6:00- 9:00)	133.6
4.	3/ 2(6:00- 9:00)	132.6
5.	3/22(6:00- 9:00)	128.6

SULFUR DIOXIDE (UG/M**3)
1-HOUR

SITE 033

1.	3/19(1:00- 2:00)	3.0
2.	3/19(2:00- 3:00)	3.0
3.	3/19(3:00- 4:00)	3.0
4.	3/19(21:00-22:00)	3.0
5.	3/19(22:00-23:00)	3.0

TABLE 14. THE FIVE MAXIMUM INDEPENDENT SLIDING AVERAGES FOR MAR 1, 1980 - MAR 31, 1980
(cont.)SULFUR DIOXIDE (UG/M**3)
3-HOUR

SITE 033

1.	3/29(5:00- 8:00)	3.0
2.	3/19(1:00- 4:00)	3.0
3.	3/28(10:00-13:00)	3.0
4.	3/28(13:00-16:00)	3.0
5.	3/28(16:00-19:00)	3.0

SULFUR DIOXIDE (UG/M**3)
24-HOUR

SITE 033

1.	3/28(10:00-10:00)	3.0
2.	3/18(23:00-23:00)	0.6
3.	3/ 3(22:00-22:00)	0.0
4.	3/ 4(22:00-22:00)	0.0
5.	3/ 5(22:00-22:00)	0.0

TOTAL SUSPENDED PARTICULATE (UG/M**3)
24-HOUR

SITE 033

1.	3/13(0:00- 0:00)	113.0
2.	3/31(0:00- 0:00)	48.0
3.	3/25(0:00- 0:00)	45.0
4.	3/16(0:00- 0:00)	42.0
5.	3/22(0:00- 0:00)	38.0

CORPORATION

TABLE 15. HOURLY AVERAGES OF SULFUR DIOXIDE (UG/M**3)
TRAILER NO. - 33 PERIOD(3/ 1/80 TO 3/31/80)

102

DAY	HOUR																								MEAN	
	1	2	3	4	5	6	7	8	9	10	11	12	13	14	15	16	17	18	19	20	21	22	23	24		
1	0	0	0	0	:	0	0	0	0	0	0	0	0	0	0	0	0	0	0	0	0	0	0	0	0	
2	0	0	0	0	:	0	0	0	0	0	0	0	0	0	0	0	0	0	0	0	0	0	0	0	0	0
3	0	0	0	0	:	0	0	0	0	0	0	0	0	0	0	0	0	0	0	0	0	0	0	0	0	0
4	0	0	0	0	:	0	0	0	0	0	0	0	0	0	0	0	0	0	0	0	0	0	0	0	0	0
5	0	0	0	0	:	0	0	0	0	0	0	0	0	0	0	0	0	0	0	0	0	0	0	0	0	0
6	0	0	0	0	:	0	0	0	0	0	0	0	0	0	0	0	0	0	0	0	0	0	0	0	0	0
7	0	0	0	0	:	0	0	0	0	0	0	0	0	0	0	0	0	0	0	0	0	0	0	0	0	0
8	0	0	0	0	:	0	0	0	0	0	0	0	0	0	0	0	0	0	0	0	0	0	0	0	0	0
9	0	0	0	0	:	0	0	0	0	0	0	0	0	0	0	0	0	0	0	0	0	0	0	0	0	0
10	0	0	0	0	:	0	0	0	0	0	0	0	0	0	0	:	0	0	0	0	0	0	0	0	0	0
11																										
12	0	0	0	0	:	0	0	0	0	0	0	0	0	0	0	0	0	0	0	0	0	0	0	0	0	0
13	0	0	0	0	:	0	0	0	0	0	0	0	0	0	0	0	0	0	0	0	0	0	0	0	0	0
14	0	0	0	0	:	0	0	0	0	0	0	0	0	0	0	0	0	0	0	0	0	0	0	0	0	0
15	0	0	0	0	:	0	0	0	0	0	0	0	0	0	0	0	0	0	0	0	0	0	0	0	0	0
16	0	0	0	0	:	0	0	0	0	0	0	0	0	0	0	0	0	0	0	0	0	0	0	0	0	0
17	0	0	0	0	:	0	0	0	0	0	0	0	0	0	0	0	0	0	0	0	0	0	0	0	0	0
18	0	0	0	0	:	0	0	0	0	0	0	:	0	0	0	0	0	0	0	0	0	0	0	0	0	0
19	0	3	3	3	:	0	0	0	0	0	0	0	0	0	0	0	0	0	0	0	0	0	3	3	0	1
20	0	0	0	0	:	0	0	0	0	0	0	0	0	0	0	0	0	0	0	0	0	0	0	0	0	0
21	0	0	0	0	:	0	0	0	:	:	0	0	0	0	0	0	0	0	0	0	0	0	0	0	0	0
22	0	0	0	0	:	0	0	0	0	0	0	0	0	0	0	0	0	0	0	0	0	0	0	0	0	0
23	0	0	0	0	:	0	0	0	0	0	0	0	0	0	0	0	0	0	0	0	0	0	0	0	0	0
24	0	0	0	0	:	0	0	0	0	0	0	0	0	0	0	0	0	0	0	0	0	0	0	0	0	0
25	0	0	0	0	:	0	0	0	0	0	0	0	0	0	0	0	0	0	0	0	0	0	0	0	0	0
26	0	0	0	0	:	0	0	0	0	0	0	0	0	0	0	0	0	0	0	0	0	0	0	0	0	0
27	0	0	0	0	:	0	0	0	0	0	0	0	0	0	0	0	0	0	0	0	0	0	0	0	0	0
28	0	0	0	0	:	0	0	0	0	0	3	3	3	3	3	3	3	3	3	3	3	3	3	3	3	3
29	3	3	3	3	:	3	3	3	3	3																
30																										
31																										
MEAN	0	0	0	0		0	0	0	0	0	0	0	0	0	0	0	0	0	0	0	0	0	0	0	0	0

TOTAL NUMBER OF OBSERVATIONS = 625 MEAN = 0.1
: INDICATES CALIBRATION FOR THE HOUR

TABLE 15. HOURLY AVERAGES OF HYDROGEN SULFIDE (UG/M**3) (cont.)
 TRAILER NO. - 33 PERIOD(3/ 1/80 TO 3/31/80)

DAY	HOUR																								MEAN
	1	2	3	4	5	6	7	8	9	10	11	12	13	14	15	16	17	18	19	20	21	22	23	24	
1	0	0	0	0	:	0	0	0	0	0	0	0	0	0	0	0	0	0	0	0	0	0	0	0	0
2	0	0	0	0	:	0	0	0	0	0	0	0	0	0	0	0	0	0	0	0	0	0	0	0	0
3	0	0	0	0	:	0	0	0	0	0	0	0	0	0	0	0	0	0	0	0	0	0	0	0	0
4	0	0	0	0	:	0	0	0	0	0	0	0	0	0	0	0	0	0	0	0	0	0	0	0	0
5	0	0	0	0	:	0	0	0	0	0	0	0	0	0	0	0	0	0	0	0	0	0	0	0	0
6	0	0	0	0	:	0	0	0	0	0	0	0	0	0	0	0	0	0	0	0	0	0	0	0	0
7	0	0	0	0	:	0	0	0	0	0	0	0	0	0	0	0	0	0	0	0	0	0	0	0	0
8	0	0	0	0	:	0	0	0	0	0	0	0	0	0	0	0	0	0	0	0	0	0	0	0	0
9	0	0	0	0	:	0	0	0	0	0	0	0	0	0	0	0	0	0	0	0	0	0	0	0	0
10	0	0	0	0	:	0	0	0	0	0	0	0	0	0	0	:	0	0	0	0	0	0	0	0	0
11																									
12	0	0	0	0	:	0	0	0	0	0	0	0	0	0	0	0	0	0	0	0	0	0	0	0	0
13	0	0	0	0	:	0	0	0	0	0	0	0	0	0	0	0	0	0	0	0	0	0	0	0	0
14	0	0	0	0	:	0	0	0	0	0	0	0	0	0	0	0	0	0	0	0	0	0	0	0	0
15	0	0	0	0	:	0	0	0	0	0	0	0	0	0	0	0	0	0	0	0	0	0	0	0	0
16	0	0	0	0	:	0	0	0	0	0	0	0	0	0	0	0	0	0	0	0	0	0	0	0	0
17	0	0	0	0	:	0	0	0	0	0	0	0	0	0	0	0	0	0	0	0	0	0	0	0	0
18	0	0	0	0	:	0	0	0	0	0	:	:	0	0	0	0	0	0	0	0	0	0	0	0	0
19	0	0	0	0	:	0	0	0	0	0	0	0	0	0	0	0	0	0	0	0	0	0	0	0	0
20	0	0	0	0	:	0	0	0	0	0	0	0	0	0	0	0	0	0	0	0	0	0	0	0	0
21	0	0	0	0	:	0	0	0	0	0	0	0	0	0	0	1	0	0	0	0	0	0	0	0	0
22	0	0	0	0	:	0	0	0	0	0	0	0	0	0	0	0	0	0	0	0	0	0	0	0	0
23	0	0	0	0	:	0	0	0	0	0	0	0	0	0	0	0	0	0	0	0	0	0	0	0	0
24	0	0	0	0	:	0	0	0	0	0	0	0	0	0	0	0	0	0	0	0	0	0	0	0	0
25	0	0	0	0	:	0	0	0	0	0	0	0	0	0	0	0	0	0	0	0	0	0	0	0	0
26	0	0	0	0	:	0	0	0	0	0	0	0	0	0	0	0	0	0	0	0	0	0	0	0	0
27	0	0	0	0	:	0	0	0	0	0	0	0	0	0	0	0	0	0	0	0	0	0	0	0	0
28	0	0	0	0	:	0	0	0	0	0	0	0	1	1	1	1	1	1	1	1	0	1	0	0	0
29	0	1	1	0	:	1	1	1	1	1															1
30																									
31																									
MEAN	0	0	0	0		0	0	0	0	0	0	0	0	0	0	0	0	0	0	0	0	0	0	0	0

TOTAL NUMBER OF OBSERVATIONS = 624 MEAN = 0.0
 : INDICATES CALIBRATION FOR THE HOUR

CORPORATION

TABLE 15. HOURLY AVERAGES OF METHANE ((UG/M**3) X 10**-1) (cont.)
 TRAILER NO. - 33 PERIOD(3/ 1/80 TO 3/31/80)

104

DAY	HOUR																								MEAN
	1	2	3	4	5	6	7	8	9	10	11	12	13	14	15	16	17	18	19	20	21	22	23	24	
1	104	106	114	118	:	121	117	117	117	117	118	117	117	117	119	120	119	119	120	119	120	123	122	121	117
2	124	122	124	123	:	135	129	132	137	136	129	126	126	128	125	129	129	128	127	126	133	131	132	134	129
3	136	146	153	171	:	156	197	164	168	93	104	104	103	102	102	102	101	102	102	102	101	101	101	101	122
4	101	101	101	100	:	101	102	100	100	101	102	100	100	101	101	101	101	101	104	103	105	103	103	104	102
5	103	105	101	102	:	102	103	107	111	119	117	122	118	120	118	118	125	118	117	113	125	133	228	142	120
6	129	127	132	170	:	148	129	125	120	119	119	122	125	130	132	136	137	182	159	150	150	174	152	138	139
7	135	131	120	107	:	100	99	99	99	100	100	99	98	99	98	98	98	98	99	99	98	99	100	101	103
8	101	100	100	100	:	97	104	106	100	100	99	106	100	102	98	100	107	108	103	114	109	101	105	135	104
9	159	138	135	133	:	136	138	147	143	138	125	124	124	123	128	132	131	124	126	127	126	127	131	135	133
10	128	116	111	111	:	114	129	125	126	124	112	111	113	114	112	108	110	111	110	104	106	103	107	107	114
11																									
12	97	98	98	100	:	100	101	104	103	105	101	101	102	102	103	103		:106	107	111	111	107	105	105	103
13	107	107	132	122	:	120	119	116	116	114	116	114	113	114	115	113	114	121	122	124	142	142	144	140	121
14	133	164	159	146	:	142	164		125	111	112	112	111	116	114	113	117	120	124	142	122	124	126	125	128
15	119	131	139	126	:	145	143	122	118	121	131	131	125	130	128	144	140	137	112	141	118	120	119	112	128
16	108	110	109	106	:	102	102	102	102	102	103	103	103	85	73	79	79	73							97
17												55	113	98	84	59	91	61							80
18								37	25	161	183	180	179	120	104	102	103	105	119	109	129	127	114	119	
19	111	117	108	107	:	126	119	114	119	129	125	111	114	117	118	107	106	106	105	104	102	102	101	101	112
20	99	98	99	100	:	99	98	98	98																99
21																									111
22	109	109	112	124	:	143	133	131	122	118	120	118	117	125	127	127	140	132	129	141	159	126	115	117	126
23	122	113	105	102	:	106	103	102	101	101	101	101	101	101	100	102	100	101	100	105	102	103	106	104	104
24	108	117	112	109	:	112	116	121	109	108	110	109	123	117	112	111	111	115	115	117	133	138	121	134	116
25	124	146	156	167	:	127	121	117	122	121	116	116	111	112	113	110	111	112	112	113	115	115	115	116	121
26	118	123	136	138	:	119	124	122	121	118	108	110	134	127	144	116	102	102	101	101	104	117	123	123	119
27	121	120	120	118	:	118	113	115	114	113	113	107	109	117	139	128	126	119	112	118	111	116	116	115	117
28	120	121	131	137	:	167	154	128	119	115	122	118	118	112	109	108	106	108	110	112	111	114	114	118	121
29	116	105	102	102	105	109	100	97	97	97															103
30																									
31																									
MEAN	117	119	120	122	105	122	122	117	113	110	115	115	114	116	114	112	111	113	112	117	118	119	122	119	

TOTAL NUMBER OF OBSERVATIONS = 574 MEAN = 116.4

: INDICATES CALIBRATION FOR THE HOUR

IX. APRIL METHANE BAG SAMPLING PROGRAM

Grab-bag samples are collected bi-weekly and analyzed for methane. The ambient air samples are collected in tedlar bags using a metal bellows pump connected to the ambient sample manifold. Each bag sample is collected over a three-hour period.

The bag samples are returned to Austin for analysis for methane concentration. The analysis is performed on either a Bendix 8202 or a Baseline Industries Model 1030 gas chromatograph using a flame ionization detector. The minimum detectable limit using this technique is less than 1 ppm.

Results of the bag sampling analyses are given below:

<u>Date</u>	<u>Time</u>	<u>Methane Concentration (ppm)</u>
4/2/80	0600-0900	2.49
4/29/80	0600-0900	2.67

TABLE 16.
DOWNTIME HOURS FOR CHOCOLATE BAYOU, TEXAS, 1980
(APRIL)

SITE 033 DIGITIZING					
DATE	SYSTEM	SO2	H2S	CH4	TSP
4/ 1	9	0	1	0	-
4/ 2	0	0	0	0	-
4/ 3	0	0	0	0	0
4/ 4	0	0	0	0	-
4/ 5	0	0	0	0	-
4/ 6	0	0	0	0	0
4/ 7	0	0	0	0	-
4/ 8	0	0	0	0	-
4/ 9	0	0	0	0	0
4/10	0	0	0	0	-
4/11	0	0	0	0	-
4/12	0	0	0	0	0
4/13	0	0	0	0	-
4/14	0	0	0	0	-
4/15	0	0	0	0	0
4/16	0	0	0	0	-
4/17	0	0	0	0	-
4/18	0	0	0	0	0
4/19	0	0	0	0	-
4/20	0	0	0	0	-
4/21	0	6	7	0	0
4/22	0	0	0	0	-
4/23	0	0	0	0	-
4/24	0	0	0	0	0
4/25	0	0	0	0	-
4/26	0	0	0	0	-
4/27	1	0	0	0	0
4/28	0	0	0	0	-
4/29	0	0	0	0	-
4/30	0	0	0	0	0
CAL TIME		29	33	39	
DATA CAPTURE RATE (%)		98	98	99	100

Downtime Summary for April 1980

EPA Guidelines for PSD air quality monitoring recommend a minimum data capture rate of 80 percent for criteria pollutants.

Data recovery rates for all the air quality parameters were excellent for the month of April.

TABLE 17.
FEDERAL AND TEXAS STATE AMBIENT AIR QUALITY STANDARDS (APRIL)

Agency	Pollutant	Special Conditions		µg/m ³ Primary	(PPM)	µg/m ³ Secondary	(PPM)
Federal and Texas	SO ₂		Annual	80	.03		
			24-Hour*	365	.14		
			3-Hour*	---		1300	.5
Texas	SO ₂	All Counties Except	30-Minute**	1061	.4	----	
		Harris, Galveston	30-Minute**	743	.28	----	
		Orange, Jefferson	30-Minute**	849	.32	----	
Federal and Texas	Particulate		Annual***	75		60	
			24-Hour*	260		150	
Texas	Particulate		5-Hour**	100		---	
			3-Hour**	200		---	
			1-Hour**	400		---	
Federal and Texas	CO		8-Hour*	10,000	9.	10,000	9.
			1-Hour*	40,000	35.	40,000	35.
Federal and Texas	Photochemical Oxidant HC (Non-Methane) NO ₂	6-9 a.m.	1-Hour†	235	.12	235	.12
			3-Hour*	160	.24	160	.24
			Annual	100	.05	100	.05

*Not to be exceeded more than once per year.

**Texas special regulations. Single plant source may not exceed these ambient levels in Texas at any point, at any time.

***Geometric Mean.

†The expected number of exceedances not to occur on more than one calendar day per year.

TABLE 18. DAILY AVERAGES FOR APR 1 1980 THRU APR 30 1980

SULFUR DIOXIDE (UG/M**3)

HYDROGEN SULFIDE (UG/M**3)

METHANE((UG/M**3) X 10**-1)

SITE DATE	033	033	033
APR 01	0.0	0.0	117.9
APR 02	0.0	0.0	119.4
APR 03	0.0	0.0	123.1
APR 04	0.0	0.0	114.2
APR 05	0.0	0.0	121.4
APR 06	0.0	0.0	105.9
APR 07	0.0	0.0	97.4
APR 08	0.0	0.0	108.2
APR 09	0.0	0.0	132.6
APR 10	0.0	0.0	121.3
APR 11	0.0	0.0	97.9
APR 12	0.0	0.0	108.5
APR 13	0.0	0.0	105.7
APR 14	0.0	0.0	112.6
APR 15	0.0	0.2	111.8
APR 16	0.0	0.0	104.7
APR 17	0.0	0.0	104.3
APR 18	0.0	0.0	112.6
APR 19	0.0	0.0	144.1
APR 20	0.0	0.2	119.0
APR 21	0.0	0.7	99.8
APR 22	0.0	0.0	93.6
APR 23	0.0	0.0	115.3
APR 24	0.0	0.0	115.3
APR 25	0.0	0.0	123.3
APR 26	0.0	0.0	131.5
APR 27	0.0	0.0	144.0
APR 28	0.0	0.0	154.5
APR 29	0.0	0.0	114.5
APR 30	0.0	0.0	110.3
APR 01 -30	0.0	0.0	116.1

TABLE 18. DAILY AVERAGES FOR APR 1 1980 THRU APR 30 1980 (cont.)

TOTAL SUSPENDED PARTICULATE (UG/M**3)

SITE 033
DATE

APR 01	
APR 02	
APR 03	61.0
APR 04	
APR 05	
APR 06	34.0
APR 07	
APR 08	
APR 09	52.0
APR 10	
APR 11	
APR 12	50.0
APR 13	
APR 14	
APR 15	53.0
APR 16	
APR 17	
APR 18	29.0
APR 19	
APR 20	
APR 21	35.0
APR 22	
APR 23	
APR 24	54.0
APR 25	
APR 26	
APR 27	52.0
APR 28	
APR 29	
APR 30	49.0

APR 01 -30 45.7

TABLE 19. THE FIVE MAXIMUM INDEPENDENT SLIDING AVERAGES FOR APR 1, 1980 - APR 30, 1980

SULFUR DIOXIDE (UG/M**3)
3-HOUR

SITE	033	
1.	4/ 1(10:00-13:00)	0.0
2.	4/ 1(13:00-16:00)	0.0
3.	4/ 1(16:00-19:00)	0.0
4.	4/ 1(19:00-22:00)	0.0
5.	4/ 1(22:00- 1:00)	0.0

SULFUR DIOXIDE (UG/M**3)
24-HOUR

SITE	033	
1.	4/ 1(9:00- 9:00)	0.0
2.	4/ 2(9:00- 9:00)	0.0
3.	4/ 3(9:00- 9:00)	0.0
4.	4/ 4(9:00- 9:00)	0.0
5.	4/ 5(9:00- 9:00)	0.0

TOTAL SUSPENDED PARTICULATE (UG/M**3)
24-HOUR

SITE	033	
1.	4/ 3(0:00- 0:00)	61.0
2.	4/24(0:00- 0:00)	54.0
3.	4/15(0:00- 0:00)	53.0
4.	4/ 9(0:00- 0:00)	52.0
5.	4/27(0:00- 0:00)	52.0

TABLE 19. THE FIVE MAXIMUM INDEPENDENT SLIDING AVERAGES FOR APR 1, 1980 - APR 30, 1980
(cont.)

HYDROGEN SULFIDE (UG/M**3)
1-HOUR

SITE	033
1.	4/15(10:00-11:00) 4.0
2.	4/20(7:00- 8:00) 4.0
3.	4/20(23:00- 0:00) 1.0
4.	4/21(0:00- 1:00) 1.0
5.	4/21(12:00-13:00) 1.0

METHANE ((UG/M**3)X10**-1)
6-9 AM

SITE	033
1.	4/28(6:00- 9:00) 241.3
2.	4/19(6:00- 9:00) 226.3
3.	4/ 9(6:00- 9:00) 204.0
4.	4/10(6:00- 9:00) 150.3
5.	4/27(6:00- 9:00) 145.6

SULFUR DIOXIDE (UG/M**3)
1-HOUR

SITE	033
1.	4/ 1(10:00-11:00) 0.0
2.	4/ 1(11:00-12:00) 0.0
3.	4/ 1(12:00-13:00) 0.0
4.	4/ 1(13:00-14:00) 0.0
5.	4/ 1(14:00-15:00) 0.0

TABLE 20. HOURLY AVERAGES OF SULFUR DIOXIDE (UG/M**3)
TRAILER NO. - 33 PERIOD(4/ 1/80 TO 4/30/80)

DAY	HOUR																								MEAN
	1	2	3	4	5	6	7	8	9	10	11	12	13	14	15	16	17	18	19	20	21	22	23	24	
1					:	0	0	0	0	0	:	0	0	0	0	0	0	0	0	0	0	0	0	0	0
2	0	0	0	0	:	0	0	0	0	0	:	0	0	0	0	0	0	0	0	0	0	0	0	0	0
3	0	0	0	0	:	0	0	0	0	0	:	0	0	0	0	0	0	0	0	0	0	0	0	0	0
4	0	0	0	0	:	0	0	0	0	0	:	0	0	0	0	0	0	0	0	0	0	0	0	0	0
5	0	0	0	0	:	0	0	0	0	0	:	0	0	0	0	0	0	0	0	0	0	0	0	0	0
6	0	0	0	0	:	0	0	0	0	0	:	0	0	0	0	0	0	0	0	0	0	0	0	0	0
7	0	0	0	0	:	0	0	0	0	0	:	0	0	0	0	0	0	0	0	0	0	0	0	0	0
8	0	0	0	0	:	0	0	0	0	0	:	0	0	0	0	0	0	0	0	0	0	0	0	0	0
9	0	0	0	0	:	0	0	0	0	0	:	0	0	0	0	0	0	0	0	0	0	0	0	0	0
10	0	0	0	0	:	0	0	0	0	0	:	0	0	0	0	0	0	0	0	0	0	0	0	0	0
11	0	0	0	0	:	0	0	0	0	0	:	0	0	0	0	0	0	0	0	0	0	0	0	0	0
12	0	0	0	0	:	0	0	0	0	0	:	0	0	0	0	0	0	0	0	0	0	0	0	0	0
13	0	0	0	0	:	0	0	0	0	0	:	0	0	0	0	0	0	0	0	0	0	0	0	0	0
14	0	0	0	0	:	0	0	0	0	0	:	0	0	0	0	0	0	0	0	0	0	0	0	0	0
15	0	0	0	0	:	0	0	0	0	0	:	0	0	0	0	0	0	0	0	0	0	0	0	0	0
16	0	0	0	0	:	0	0	0	0	0	:	0	0	0	0	0	0	0	0	0	0	0	0	0	0
17	0	0	0	0	:	0	0	0	0	0	:	0	0	0	0	0	0	0	0	0	0	0	0	0	0
18	0	0	0	0	:	0	0	0	0	0	:	0	0	0	0	0	0	0	0	0	0	0	0	0	0
19	0	0	0	0	:	0	0	0	0	0	:	0	0	0	0	0	0	0	0	0	0	0	0	0	0
20	0	0	0	0	:	0	0	0	0	0	:	0	0	0	0	0	0	0	0	0	0	0	0	0	0
21	0	0	0	0	:	0	0	0	0	0	:	0	0	0	0	0	0	0	0	0	0	0	0	0	0
22	0	0	0	0	:	0	0	0	0	0	:	0	0	0	0	0	0	0	0	0	0	0	0	0	0
23	0	0	0	0	:	0	0	0	0	0	:	0	0	0	0	0	0	0	0	0	0	0	0	0	0
24	0	0	0	0	:	0	0	0	0	0	:	0	0	0	0	0	0	0	0	0	0	0	0	0	0
25	0	0	0	0	:	0	0	0	0	0	:	0	0	0	0	0	0	0	0	0	0	0	0	0	0
26	0	0	0	0	:	0	0	0	0	0	:	0	0	0	0	0	0	0	0	0	0	0	0	0	0
27	0	0	0	0	0	:	0	0	0	0	:	0	0	0	0	0	0	0	0	0	0	0	0	0	0
28	0	0	0	0	0	:	0	0	0	0	:	0	0	0	0	0	0	0	0	0	0	0	0	0	0
29	0	0	0	0	:	0	0	0	0	0	:	0	0	0	0	0	0	0	0	0	0	0	0	0	0
30	0	0	0	0	:	0	0	0	0	0	:	0	0	0	0	0	0	0	0	0	0	0	0	0	0
MEAN	0	0	0	0	0	0	0	0	0	0	0	0	0	0	0	0	0	0	0	0	0	0	0	0	0

TOTAL NUMBER OF OBSERVATIONS = 675 MEAN = 0.0
: INDICATES CALIBRATION FOR THE HOUR

TABLE 20. HOURLY AVERAGES OF HYDROGEN SULFIDE (UG/M**3) (cont.)
TRAILER NO. - 33 PERIOD(4/ 1/80 TO 4/30/80)

DAY	HOUR																								MEAN
	1	2	3	4	5	6	7	8	9	10	11	12	13	14	15	16	17	18	19	20	21	22	23	24	
1										:	0	0	0	0	0	0	0	0	0	0	0	0	0	0	0
2	0	0	0	0	:	0	0	0	0	:	0	0	0	0	0	0	0	0	0	0	0	0	0	0	0
3	0	0	0	0	:	0	0	0	0	0	0	0	0	0	0	0	0	0	0	0	0	0	0	0	0
4	0	0	0	0	:	0	0	0	0	0	0	0	0	0	0	0	0	0	0	0	0	0	0	0	0
5	0	0	0	0	:	0	0	0	0	0	0	0	0	0	0	0	0	0	0	0	0	0	0	0	0
6	0	0	0	0	:	0	0	0	0	0	0	0	0	0	0	0	0	0	0	0	0	0	0	0	0
7	0	0	0	0	:	0	0	0	0	0	0	0	0	0	0	0	0	0	0	0	0	0	0	0	0
8	0	0	0	0	:	0	0	0	0	0	0	0	0	0	0	0	0	0	0	0	0	0	0	0	0
9	0	0	0	0	:	0	0	0	0	0	:	0	0	0	0	0	0	0	0	0	0	0	0	0	0
10	0	0	0	0	:	0	0	0	0	0	0	0	0	0	0	0	0	0	0	0	0	0	0	0	0
11	0	0	0	0	:	0	0	0	0	0	0	0	0	0	0	0	0	0	0	0	0	0	0	0	0
12	0	0	0	0	:	0	0	0	0	0	0	0	0	0	0	0	0	0	0	0	0	0	0	0	0
13	0	0	0	0	:	0	0	0	0	0	0	0	0	0	0	0	0	0	0	0	0	0	0	0	0
14	0	0	0	0	:	0	0	0	0	0	0	0	0	0	0	0	0	0	0	0	0	0	0	0	0
15	0	0	0	0	:	0	0	0	0	0	4	0	0	0	0	0	0	0	0	0	0	0	0	0	0
16	0	0	0	0	:	0	0	0	0	0	0	0	0	0	0	0	0	0	0	0	0	0	0	0	0
17	0	0	0	0	:	0	0	0	0	0	0	0	0	0	0	0	0	0	0	0	0	0	0	0	0
18	0	0	0	0	:	0	0	0	0	0	0	0	0	0	0	0	0	0	0	0	0	0	0	0	0
19	0	0	0	0	:	0	0	0	0	0	0	0	0	0	0	0	0	0	0	0	0	0	0	0	0
20	0	0	0	0	:	0	0	4	0	0	0	0	0	0	0	0	0	0	0	0	0	0	0	0	0
21	1				:					0	0	0	1	0	0	1	1	1	1	1	1	1	1	1	1
22	0	0	0	0	:	0	0	0	0	0	:	0	0	0	0	0	0	0	0	0	0	0	0	0	0
23	0	0	0	0	:	0	0	0	0	0	0	0	0	0	0	0	0	0	0	0	0	0	0	0	0
24	0	0	0	0	:	0	0	0	0	0	0	0	0	0	0	0	0	0	0	0	0	0	0	0	0
25	0	0	0	0	:	0	0	0	0	0	0	0	0	0	0	0	0	0	0	0	0	0	0	0	0
26	0	0	0	0	:	0	0	0	0	0	0	0	0	0	0	0	0	0	0	0	0	0	0	0	0
27	0	0		0	0	:	0	0	0	0	0	0	0	0	0	0	0	0	0	0	0	0	0	0	0
28	0	0	0	0	0	:	0	0	0	0	0	0	0	0	0	0	0	0	0	0	0	0	0	0	0
29	0	0	0	0	:	0	0	0	0	0	0	0	0	0	0	0	0	0	0	0	0	0	0	0	0
30	0	0	0	0	:	0	0	0	0	0	0	0	0	0	0	0	0	0	0	0	0	0	0	0	0
MEAN	0	0	0	0	0	0	0	0	0	0	0	0	0	0	0	0	0	0	0	0	0	0	0	0	0

TOTAL NUMBER OF OBSERVATIONS = 669 MEAN = 0.0
: INDICATES CALIBRATION FOR THE HOUR

TABLE 20. HOURLY AVERAGES OF METHANE((UG/M**3)X10**-1) (cont.)
TRAILER NO. - 33 PERIOD(4/ 1/80 TO 4/30/80)

DAY	HOUR																								MEAN
	1	2	3	4	5	6	7	8	9	10	11	12	13	14	15	16	17	18	19	20	21	22	23	24	
1											:142	112	109	111	113	114	118	117	118	118	122	122	119	115	118
2	113	115	114	114		:120	122	125	124	130	129	136	139	129	129	137	121	110	103	110	110	103	109	104	119
3	105	114	114	123		:114	107	106	131	141	127	119	119	118	113	115	127	121	118	124	143	145	149	139	123
4	128	137	126	120		:114	109	111	109	108	109	110	108	106	106	106	106	106	106	109	113	118	135	127	114
5	141	149	161	163		:152	149	125	121	119	110	106	105	106	105	106	108	109	110	111	108	108	109	112	121
6	118	111	114	111		:109	112	108	112	112	104	107	102	104	101	101	101	101	101	101	101	100	101	104	106
7	104	102	100	100		: 98	98	97	97	97	96	97	96	95	95	95	95	94	96	97	97	98	100	97	97
8	97	97	100	96		:103	109	109	109		:107	106	103	103	104	105	103	104	105	116	125	118	132	129	108
9	129	132	147	165		:209	224	224	164	129	106	106	106	105	107	106	106	107	107	109	115	117	117	112	133
10	113	115	125	129		:200	168	143	140	110	107	106	105	108	109	110	112	114	115	117	114	116	108	105	121
11	104	103	104	102		:100	99	99	98	97	97	93	96	96	98	97	96	96	96	96	96	96	96	96	98
12	96	96	97	97		: 97	101	108	114	114	115	113	116	112	110	113	111	114	113	111	111	112	115	110	109
13	108	110	107	106		:104	104	104	105	104	104	105	105	105	108	107	105	106	105	103	104	104	106	111	106
14	116	113	118	118		:126	131	134	125	116	114	112	106	102	102	102	103	106	112	103	107	107	107	109	113
15	109	118	117	112		:109	127	137	121	114	111	112	113	112	108	106	107	106	105	105	106	107	105	105	112
16	109	113	115	110		:113	109	107	103	102	102	102	102	101	102	101	101	101	101	101	102	102	102	104	105
17	101	103	103	106		:107	104	102	102	103	103	102	102	102	105	104	105	104	106	106	105	107	110	108	104
18	109	103	103	108		:115	119	126	115	112	105	105	104	105	106	104	104	105	109	114	113	139	129	138	113
19	148	174	201	199		:273	293	237	149	113	106	105	106	108	109	111	109	108	108	108	110	110	111	118	144
20	148	144	151	188		:136	137	137	118	114	85	101	108	108	107	106	105	104	102	106	108	99	111	115	119
21	141	148	158	175		:132	133	:	:	:	: 92	91	:	:	: 97	64	62	65	67	76	82	72	71	71	100
22	78	71	71	76		: 65	61	63	64		:109	106	103	100	104	102	103	105	107	107	110	114	115	126	94
23	121	128	128	124		:118	120	116	113	112	112	111	110	109	109	110	111	112	111	115	117	116	113	116	115
24	115	112	115	112		:111	111	111	111	111	111	112	113	114	114	116	116	118	118	120	123	124	124	121	115
25	121	120	118	116		:115	120	121	120	124	120	115	120	123	126	123	122	124	148	123	124	123	135	134	123
26	137	144	173	156		:130	129	127	124	124	123	122	122	123	122	122	121	128	125	128	130	133	138	144	132
27	141	138		140 140		:144	142	151	147	141	139	138	136	136	137	134	134	135	146	148	161	162	177	144	
28	213	227	194	191 181		:204	259	261		:	:114	110	107	109	108	108	108	110	117	125	155	114	129	154	
29	120	120	119	119		:122	127	129	121	112	112	110	109	109	109	110	110	109	110	111	110	111	112	112	114
30	113	112	111	110		:113	113	117	112	109	108	108	109	108	109	108	107	108	109	109	110	111	112	112	110
MEAN	121	123	125	127	161	126	130	129	123	115	111	109	110	109	109	108	108	108	109	111	113	115	116	117	

TOTAL NUMBER OF OBSERVATIONS = 671 MEAN = 116.1

: INDICATES CALIBRATION FOR THE HOUR

X. MAY METHANE BAG SAMPLING PROGRAM

Grab-bag samples are collected bi-weekly and analyzed for methane. The ambient air samples are collected in tedlar bags using a metal bellows pump connected to the ambient sample manifold. Each bag sample is collected over a three-hour period.

The bag samples are returned to Austin for analysis for methane concentration. The analysis is performed on either a Bendix 8202 or a Baseline Industries Model 1030 gas chromatograph using a flame ionization detector. The minimum detectable limit using this technique is less than 1 ppm.

Results of the bag sampling analyses are given below:

<u>Date</u>	<u>Time</u>	<u>Methane Concentration (ppm)</u>
5/13/80	0600-0900	2.52
5/27/80	0600-0900	1.92

TABLE 21.
DOWNTIME HOURS FOR CHOCOLATE PAYOU, TEXAS, 1980
(MAY)

SITE 033 DIGITIZING					
DATE	SYSTEM	SO2	H2S	CH4	TSP
5/ 1	0	0	0	0	-
5/ 2	0	0	0	0	-
5/ 3	0	0	0	0	0
5/ 4	0	0	0	0	-
5/ 5	0	0	0	0	-
5/ 6	0	0	0	0	0
5/ 7	0	0	0	0	-
5/ 8	0	0	0	0	-
5/ 9	0	0	0	0	0
5/10	0	0	0	0	-
5/11	0	0	0	0	-
5/12	0	0	0	0	0
5/13	0	0	0	0	-
5/14	0	0	0	0	-
5/15	0	0	0	0	0
5/16	0	0	0	0	-
5/17	0	0	0	0	-
5/18	0	0	0	0	0
5/19	0	0	0	0	-
5/20	0	0	0	0	-
5/21	0	0	0	0	0
5/22	0	0	0	0	-
5/23	0	0	0	0	-
5/24	0	0	0	0	0
5/25	0	0	0	0	-
5/26	0	0	0	0	-
5/27	0	0	0	0	0
5/28	0	0	0	0	-
5/29	0	0	0	0	-
5/30	0	0	0	0	0
5/31	0	0	0	0	-
CAL TIME		31	31	32	
DATA CAPTURE RATE (%)		100	100	100	100

Downtime Summary for May 1980

During May operations at the Chocolate Bayou site were optimal. The data capture rates for all parameters were the highest attainable, 100 percent.

TABLE 22.

FEDERAL AND TEXAS STATE AMBIENT AIR QUALITY STANDARDS (MAY)

Agency	Pollutant	Special Conditions		$\mu\text{g}/\text{m}^3$ Primary	(PPM)	$\mu\text{g}/\text{m}^3$ Secondary	(PPM)	
Federal and Texas	SO ₂		Annual	80	.03			
			24-Hour*	365	.14			
			3-Hour*	---		1300	.5	
Texas	SO ₂	All Counties Except	30-Minute**	1061	.4	----		
			Harris, Galveston	30-Minute**	743	.28	----	
				Orange, Jefferson	30-Minute**	849	.32	----
Federal and Texas	Particulate		Annual***	75		60		
			24-Hour*	260		150		
Texas	Particulate		5-Hour**	100		---		
			3-Hour**	200		---		
			1-Hour**	400		---		
Federal and Texas	CO		8-Hour*	10,000	9.	10,000	9.	
			1-Hour*	40,000	35.	40,000	35.	
Federal and Texas	Photochemical Oxidant HC (Non-Methane) NO ₂	6-9 a.m.	1-Hour†	235	.12	235	.12	
			3-Hour*	160	.24	160	.24	
			Annual	100	.05	100	.05	

*Not to be exceeded more than once per year.

**Texas special regulations. Single plant source may not exceed these ambient levels in Texas at any point, at any time.

***Geometric Mean.

†The expected number of exceedances not to occur on more than one calendar day per year.

TABLE 23. DAILY AVERAGES FOR MAY 1 1980 THRU MAY 31 1980

120

SITE DATE	SULFUR DIOXIDE (UG/M**3)	HYDROGEN SULFIDE (UG/M**3)	METHANE((UG/M**3)X10**-1)
	033	033	033
MAY 01	0.0	0.0	115.5
MAY 02	0.0	0.0	121.3
MAY 03	0.0	0.0	133.7
MAY 04	0.0	0.0	121.9
MAY 05	0.0	0.0	120.0
MAY 06	0.0	0.0	108.5
MAY 07	0.0	0.0	104.1
MAY 08	0.0	0.0	110.5
MAY 09	0.0	0.0	114.5
MAY 10	0.0	0.0	103.9
MAY 11	0.0	0.0	99.7
MAY 12	0.0	0.0	97.0
MAY 13	0.0	0.0	99.7
MAY 14	0.0	0.0	105.0
MAY 15	0.0	0.0	107.0
MAY 16	0.0	0.0	109.0
MAY 17	0.0	0.0	119.6
MAY 18	0.0	0.0	108.8
MAY 19	0.0	0.0	108.5
MAY 20	0.0	0.0	121.4
MAY 21	0.0	0.0	106.8
MAY 22	0.0	0.0	117.0
MAY 23	0.0	0.0	122.1
MAY 24	0.0	0.0	97.2
MAY 25	0.0	0.0	96.0
MAY 26	0.0	0.0	106.7
MAY 27	0.0	0.0	115.2
MAY 28	0.0	0.0	106.2
MAY 29	0.0	0.0	102.1
MAY 30	0.0	0.0	101.3
MAY 31	0.0	0.0	99.6
MAY 01 -31	0.0	0.0	109.7

TABLE 23. DAILY AVERAGES FOR MAY 1 1980 THRU MAY 31 1980 (cont.)

TOTAL SUSPENDED PARTICULATE(UG/M**3)

SITE	033
DATE	
MAY 01	
MAY 02	
MAY 03	43.0
MAY 04	
MAY 05	
MAY 06	37.0
MAY 07	
MAY 08	
MAY 09	50.0
MAY 10	
MAY 11	
MAY 12	48.0
MAY 13	
MAY 14	
MAY 15	64.0
MAY 16	
MAY 17	
MAY 18	25.0
MAY 19	
MAY 20	
MAY 21	27.0
MAY 22	
MAY 23	
MAY 24	48.0
MAY 25	
MAY 26	
MAY 27	42.0
MAY 28	
MAY 29	
MAY 30	47.0
MAY 31	
MAY 01 -31	41.6

TABLE 24. THE FIVE MAXIMUM INDEPENDENT SLIDING AVERAGES FOR MAY 1, 1980 - MAY 31, 1980

SULFUR DIOXIDE (UG/M**3)
3-HOUR

SITE 033

1.	5/ 1(0:00- 3:00)	0.0
2.	5/ 1(5:00- 8:00)	0.0
3.	5/ 1(8:00-11:00)	0.0
4.	5/ 1(11:00-14:00)	0.0
5.	5/ 1(14:00-17:00)	0.0

SULFUR DIOXIDE (UG/M**3)
24-HOUR

SITE 033

1.	5/ 1(0:00- 0:00)	0.0
2.	5/ 2(0:00- 0:00)	0.0
3.	5/ 3(0:00- 0:00)	0.0
4.	5/ 4(0:00- 0:00)	0.0
5.	5/ 5(0:00- 0:00)	0.0

TOTAL SUSPENDED PARTICULATE (UG/M**3)
24-HOUR

SITE 033

1.	5/15(0:00- 0:00)	64.0
2.	5/ 9(0:00- 0:00)	50.0
3.	5/24(0:00- 0:00)	48.0
4.	5/12(0:00- 0:00)	48.0
5.	5/30(0:00- 0:00)	47.0

TABLE 24. THE FIVE MAXIMUM INDEPENDENT SLIDING AVERAGES FOR MAY 1, 1980 - MAY 31, 1980
(cont.)

HYDROGEN SULFIDE (UG/M**3)
1-HOUR

SITE	033
1.	5/ 1(0:00- 1:00) 0.0
2.	5/ 1(1:00- 2:00) 0.0
3.	5/ 1(2:00- 3:00) 0.0
4.	5/ 1(3:00- 4:00) 0.0
5.	5/ 1(5:00- 6:00) 0.0

METHANE ((UG/M**3)X10**-1)
6-9 AM

SITE	033
1.	5/ 3(6:00- 9:00) 191.3
2.	5/23(6:00- 9:00) 176.3
3.	5/ 5(6:00- 9:00) 149.3
4.	5/ 4(6:00- 9:00) 148.6
5.	5/20(6:00- 9:00) 148.0

SULFUR DIOXIDE (UG/M**3)
1-HOUR

SITE	033
1.	5/ 1(0:00- 1:00) 0.0
2.	5/ 1(1:00- 2:00) 0.0
3.	5/ 1(2:00- 3:00) 0.0
4.	5/ 1(3:00- 4:00) 0.0
5.	5/ 1(5:00- 6:00) 0.0

TABLE 25. HOURLY AVERAGES OF SULFUR DIOXIDE (UG/M**3)
TRAILER NO. - 33 PERIOD(5/ 1/80 TO 5/31/80)

DAY	HOUR																								MEAN
	1	2	3	4	5	6	7	8	9	10	11	12	13	14	15	16	17	18	19	20	21	22	23	24	
1	0	0	0	0	:	0	0	0	0	0	0	0	0	0	0	0	0	0	0	0	0	0	0	0	0
2	0	0	0	0	:	0	0	0	0	0	0	0	0	0	0	0	0	0	0	0	0	0	0	0	0
3	0	0	0	0	:	0	0	0	0	0	0	0	0	0	0	0	0	0	0	0	0	0	0	0	0
4	0	0	0	0	:	0	0	0	0	0	0	0	0	0	0	0	0	0	0	0	0	0	0	0	0
5	0	0	0	0	:	0	0	0	0	0	0	0	0	0	0	0	0	0	0	0	0	0	0	0	0
6	0	0	0	0	:	0	0	0	0	0	0	0	0	0	0	0	0	0	0	0	0	0	0	0	0
7	0	0	0	0	:	0	0	0	0	0	0	0	0	0	0	0	0	0	0	0	0	0	0	0	0
8	0	0	0	0	:	0	0	0	0	0	0	0	0	0	0	0	0	0	0	0	0	0	0	0	0
9	0	0	0	0	:	0	0	0	0	0	0	0	0	0	0	0	0	0	0	0	0	0	0	0	0
10	0	0	0	0	:	0	0	0	0	0	0	0	0	0	0	0	0	0	0	0	0	0	0	0	0
11	0	0	0	0	:	0	0	0	0	0	0	0	0	0	0	0	0	0	0	0	0	0	0	0	0
12	0	0	0	0	:	0	0	0	0	0	0	0	0	0	0	0	0	0	0	0	0	0	0	0	0
13	0	0	0	0	:	0	0	0	0	0	0	0	0	0	0	0	0	0	0	0	0	0	0	0	0
14	0	0	0	0	:	0	0	0	0	0	0	0	0	0	0	0	0	0	0	0	0	0	0	0	0
15	0	0	0	0	:	0	0	0	0	0	0	0	0	0	0	0	0	0	0	0	0	0	0	0	0
16	0	0	0	0	0	:	0	0	0	0	0	0	0	0	0	0	0	0	0	0	0	0	0	0	0
17	0	0	0	0	:	0	0	0	0	0	0	0	0	0	0	0	0	0	0	0	0	0	0	0	0
18	0	0	0	0	:	0	0	0	0	0	0	0	0	0	0	0	0	0	0	0	0	0	0	0	0
19	0	0	0	0	:	0	0	0	0	0	0	0	0	0	0	0	0	0	0	0	0	0	0	0	0
20	0	0	0	0	:	0	0	0	0	0	0	0	0	0	0	0	0	0	0	0	0	0	0	0	0
21	0	0	0	0	:	0	0	0	0	0	0	0	0	0	0	0	0	0	0	0	0	0	0	0	0
22	0	0	0	0	:	0	0	0	0	0	0	0	0	0	0	0	0	0	0	0	0	0	0	0	0
23	0	0	0	0	:	0	0	0	0	0	0	0	0	0	0	0	0	0	0	0	0	0	0	0	0
24	0	0	0	0	:	0	0	0	0	0	0	0	0	0	0	0	0	0	0	0	0	0	0	0	0
25	0	0	0	0	:	0	0	0	0	0	0	0	0	0	0	0	0	0	0	0	0	0	0	0	0
26	0	0	0	0	:	0	0	0	0	0	0	0	0	0	0	0	0	0	0	0	0	0	0	0	0
27	0	0	0	0	:	0	0	0	0	0	0	0	0	0	0	0	0	0	0	0	0	0	0	0	0
28	0	0	0	0	:	0	0	0	0	0	0	0	0	0	0	0	0	0	0	0	0	0	0	0	0
29	0	0	0	0	:	0	0	0	0	0	0	0	0	0	0	0	0	0	0	0	0	0	0	0	0
30	0	0	0	0	:	0	0	0	0	0	0	0	0	0	0	0	0	0	0	0	0	0	0	0	0
31	0	0	0	0	:	0	0	0	0	0	0	0	0	0	0	0	0	0	0	0	0	0	0	0	0
MEAN	0	0	0	0	0	0	0	0	0	0	0	0	0	0	0	0	0	0	0	0	0	0	0	0	0

TOTAL NUMBER OF OBSERVATIONS = 713 MEAN = 0.0
: INDICATES CALIBRATION FOR THE HOUR

TABLE 25. HOURLY AVERAGES OF HYDROGEN SULFIDE (UG/M**3) (cont.)
TRAILER NO. - 33 PERIOD(5/ 1/80 TO 5/31/80)

DAY	HOUR																								MEAN
	1	2	3	4	5	6	7	8	9	10	11	12	13	14	15	16	17	18	19	20	21	22	23	24	
1	0	0	0	0	:	0	0	0	0	0	0	0	0	0	0	0	0	0	0	0	0	0	0	0	0
2	0	0	0	0	:	0	0	0	0	0	0	0	0	0	0	0	0	0	0	0	0	0	0	0	0
3	0	0	0	0	:	0	0	0	0	0	0	0	0	0	0	0	0	0	0	0	0	0	0	0	0
4	0	0	0	0	:	0	0	0	0	0	0	0	0	0	0	0	0	0	0	0	0	0	0	0	0
5	0	0	0	0	:	0	0	0	0	0	0	0	0	0	0	0	0	0	0	0	0	0	0	0	0
6	0	0	0	0	:	0	0	0	0	0	0	0	0	0	0	0	0	0	0	0	0	0	0	0	0
7	0	0	0	0	:	0	0	0	0	0	0	0	0	0	0	0	0	0	0	0	0	0	0	0	0
8	0	0	0	0	:	0	0	0	0	0	0	0	0	0	0	0	0	0	0	0	0	0	0	0	0
9	0	0	0	0	:	0	0	0	0	0	0	0	0	0	0	0	0	0	0	0	0	0	0	0	0
10	0	0	0	0	:	0	0	0	0	0	0	0	0	0	0	0	0	0	0	0	0	0	0	0	0
11	0	0	0	0	:	0	0	0	0	0	0	0	0	0	0	0	0	0	0	0	0	0	0	0	0
12	0	0	0	0	:	0	0	0	0	0	0	0	0	0	0	0	0	0	0	0	0	0	0	0	0
13	0	0	0	0	:	0	0	0	0	0	0	0	0	0	0	0	0	0	0	0	0	0	0	0	0
14	0	0	0	0	:	0	0	0	0	0	0	0	0	0	0	0	0	0	0	0	0	0	0	0	0
15	0	0	0	0	:	0	0	0	0	0	0	0	0	0	0	0	0	0	0	0	0	0	0	0	0
16	0	0	0	0	0	:	0	0	0	0	0	0	0	0	0	0	0	0	0	0	0	0	0	0	0
17	0	0	0	0	:	0	0	0	0	0	0	0	0	0	0	0	0	0	0	0	0	0	0	0	0
18	0	0	0	0	:	0	0	0	0	0	0	0	0	0	0	0	0	0	0	0	0	0	0	0	0
19	0	0	0	0	:	0	0	0	0	0	0	0	0	0	0	0	0	0	0	0	0	0	0	0	0
20	0	0	0	0	:	0	0	0	0	0	0	0	0	0	0	0	0	0	0	0	0	0	0	0	0
21	0	0	0	0	:	0	0	0	0	0	0	0	0	0	0	0	0	0	0	0	0	0	0	0	0
22	0	0	0	0	:	0	0	0	0	0	0	0	0	0	0	0	0	0	0	0	0	0	0	0	0
23	0	0	0	0	:	0	0	0	0	0	0	0	0	0	0	0	0	0	0	0	0	0	0	0	0
24	0	0	0	0	:	0	0	0	0	0	0	0	0	0	0	0	0	0	0	0	0	0	0	0	0
25	0	0	0	0	:	0	0	0	0	0	0	0	0	0	0	0	0	0	0	0	0	0	0	0	0
26	0	0	0	0	:	0	0	0	0	0	0	0	0	0	0	0	0	0	0	0	0	0	0	0	0
27	0	0	0	0	:	0	0	0	0	0	0	0	0	0	0	0	0	0	0	0	0	0	0	0	0
28	0	0	0	0	:	0	0	0	0	0	0	0	0	0	0	0	0	0	0	0	0	0	0	0	0
29	0	0	0	0	:	0	0	0	0	0	0	0	0	0	0	0	0	0	0	0	0	0	0	0	0
30	0	0	0	0	:	0	0	0	0	0	0	0	0	0	0	0	0	0	0	0	0	0	0	0	0
31	0	0	0	0	:	0	0	0	0	0	0	0	0	0	0	0	0	0	0	0	0	0	0	0	0
MEAN	0	0	0	0	0	0	0	0	0	0	0	0	0	0	0	0	0	0	0	0	0	0	0	0	0

TOTAL NUMBER OF OBSERVATIONS = 713 MEAN = 0.0
: INDICATES CALIBRATION FOR THE HOUR

TABLE 25. HOURLY AVERAGES OF METHANE((UG/M**3)X10**-1) (cont.)
TRAILER NO. - 33 PERIOD(5/ 1/80 TO 5/31/80)

DAY	HOUR																								MEAN
	1	2	3	4	5	6	7	8	9	10	11	12	13	14	15	16	17	18	19	20	21	22	23	24	
1	116	124	116	120	:	157	143	130	123	110	:	105	103	104	106	105	105	107	112	112	110	111	109	113	116
2	109	115	128	129	:	135	125	134	135	142	134	119	114	125	122	116	109	105	107	120	111	116	119	121	121
3	117	140	157	152	:	180	209	196	169	131	114	112	113	109	110	113	118	108	108	109	111	112	147	141	134
4	126	118	121	130	:	163	158	137	151	127	114	112	112	111	110	110	108	107	107	112	115	117	118	120	122
5	123	128	128	129	:	135	144	151	153	131	114	110	109	109	112	110	108	107	103	109	108	110	113	112	120
6	115	110	109	110	:	118	116	121	115	110	113	108	104	105	105	103	102	101	102	104	107	106	107	105	109
7	104	107	106	109	:	108	108	109	121	109	102	101	101	101	102	101	100	100	100	101	101	101	101	102	104
8	103	104	104	106	:	105	110	106	109	104	108	105	105	106	101	104	108	108	113	124	128	126	137	117	110
9	116	117	119	112	:	121	131	129	117	112	113	114	115	114	113	110	113	115	110	109	108	108	108	110	115
10	109	109	109	108	:	106	109	108	108	108	107	104	103	103	102	101	100	100	99	99	100	100	99	99	104
11	98	98	98	99	:	98	100	100	99	99	99	99	99	99	98	98	99	100	101	102	104	104	100	103	100
12	101	97	97	97	:	96	96	96	97	95	96	96	96	96	96	96	96	95	95	96	98	103	103	96	97
13	95	95	95	95	:	97	99	97	101	101	102	99	99	98	98	102	99	98	98	96	101	107	104	116	100
14	108	107	106	106	:	105	104	106	102	122	127	102	100	99	100	100	99	99	97	100	97	115	114	100	105
15	96	187	159	104	:	101	103	99	98	97	104	100	108	104	103	102	100	100	99	99	100	99	99	99	107
16	99	100	99	101	102	114	103	:	103	114	143	122	117	113	111	109	119	112	108	106	105	102	102	104	109
17	103	102	105	124	:	120	119	183	117	106	105	109	106	107	174	132	109	109	111	119	120	137	120	114	120
18	120	123	119	111	:	120	113	113	110	110	106	107	105	103	106	105	106	108	107	101	101	103	104	101	109
19	104	111	104	118	:	103	108	115	121	100	100	107	113	117	108	110	110	104	107	108	109	103	110	106	109
20	111	109	127	121	:	136	146	149	149	137	128	123	122	119	120	119	124	118	112	108	105	104	103	103	121
21	103	106	113	111	:	114	115	107	105	107	102	101	103	103	107	106	100	100	100	100	102	108	122	121	107
22	115	117	111	129	:	126	133	130	132	138	123	117	108	107	107	106	106	108	110	127	110	111	113	117	
23	114	115	119	134	:	165	177	198	154	137	123	113	107	109	105	105	106	106	106	104	105	105	103	99	122
24	98	97	97	98	:	95	102	101	102	99	96	96	96	98	96	96	96	95	97	95	95	98	96	96	97
25	96	96	95	95	:	96	96	97	96	95	96	96	96	96	97	96	96	96	96	96	96	96	97	96	96
26	97	97	99	107	:	111	119	117	113	115	115	107	111	107	98	101	102	102	102	101	104	118	108	104	107
27	103	109	107	115	:	134	136	137	127	117	116	131	112	109	108	105	103	106	109	109	107	114	117	118	115
28	120	116	110	110	:	107	109	107	104	103	102	102	102	102	102	103	105	105	106	105	106	105	106	105	106
29	102	104	107	100	:	99	101	103	100	100	100	100	103	102	102	102	103	103	103	107	106	102	100	100	102
30	100	100	100	99	:	100	104	99	99	101	101	101	100	100	100	100	101	101	101	102	102	111	104	104	101
31	104	102	99	99	:	100	105	101	99	99	100	99	99	98	99	99	98	98	99	99	98	98	99	99	100
MEAN	107	112	112	112	102	118	121	123	117	112	110	107	106	106	107	105	105	104	104	105	106	103	109	108	

TOTAL NUMBER OF OBSERVATIONS = 712 MEAN = 109.7
: INDICATES CALIBRATION FOR THE HOUR

XI. JUNE METHANE BAG SAMPLING PROGRAM

Grab-bag samples are collected bi-weekly and analyzed for methane. The ambient air samples are collected in tedlar bags using a metal bellows pump connected to the ambient sample manifold. Each bag sample is collected over a three-hour period.

The bag samples are returned to Austin for analysis for methane concentration. The analysis is performed on either a Bendix 8202 or a Baseline Industries Model 1030 gas chromatograph using a flame ionization detector. The minimum detectable limit using this technique is less than 1 ppm.

Results of the bag sampling analyses are given below:

<u>Date</u>	<u>Time</u>	<u>Methane Concentration (ppm)</u>
6-10-80	0600-0900	1.77
6-24-80	0600-0900	2.70

TABLE 26.
DOWNTIME HOURS FOR CHOCOLATE BAYOU, TEXAS, 1980
(JUNE)

SITE 033 DIGITIZING		SO2	H2S	CH4	TSP
DATE	SYSTEM				
6/ 1	0	0	0	0	-
6/ 2	0	0	0	0	0
6/ 3	0	0	0	0	-
6/ 4	0	0	0	0	-
6/ 5	0	0	0	0	0
6/ 6	0	0	0	0	-
6/ 7	0	0	0	0	-
6/ 8	0	0	0	0	0
6/ 9	0	0	0	0	-
6/10	0	0	0	0	-
6/11	0	0	0	0	0
6/12	0	0	0	0	-
6/13	0	0	0	0	-
6/14	0	0	0	0	0
6/15	0	0	0	0	-
6/16	0	0	0	0	0
6/17	0	0	0	0	-
6/18	0	0	0	0	-
6/19	0	0	0	0	-
6/20	0	0	0	0	0
6/21	0	0	0	0	-
6/22	0	0	0	0	-
6/23	0	0	0	0	0
6/24	0	0	0	0	-
6/25	0	0	0	0	-
6/26	0	0	0	0	0
6/27	0	0	0	0	0
6/28	0	0	0	0	-
6/29	0	0	0	0	0
6/30	0	0	0	0	-
CAL TIME		34	33	14	
DATA CAPTURE RATE (%)		100	100	100	100

Downtime Summary for June 1980

During June operations at the Chocolate Bayou site were optimal. The data capture rates for all parameters were the highest attainable, 100 percent.

TABLE 27.

FEDERAL AND TEXAS STATE AMBIENT AIR QUALITY STANDARDS (JUNE)

Agency	Pollutant	Special Conditions		$\mu\text{g}/\text{m}^3$ Primary	(PPM)	$\mu\text{g}/\text{m}^3$ Secondary	(PPM)	
Federal and Texas	SO ₂		Annual	80	.03			
			24-Hour*	365	.14			
			3-Hour*	---		1300	.5	
Texas	SO ₂	All Counties Except	30-Minute**	1061	.4	----		
			Harris, Galveston	30-Minute**	743	.28	----	
			Orange, Jefferson	30-Minute**	849	.32	----	
Federal and Texas	Particulate		Annual***	75		60		
			24-Hour*	260		150		
Texas	Particulate		5-Hour**	100		---		
			3-Hour**	200		---		
			1-Hour**	400		---		
Federal and Texas	CO		8-Hour*	10,000	9.	10,000	9.	
			1-Hour*	40,000	35.	40,000	35.	
Federal and Texas	Ozone HC (Non-Methane) NO ₂	6-9 a.m.	1-Hour†	235	.12	235	.12	
			3-Hour*	160	.24	160	.24	
			Annual	100	.05	100	.05	

*Not to be exceeded more than once per year.

**Texas special regulations. Single plant source may not exceed these ambient levels in Texas at any point, at any time.

***Geometric Mean.

†The expected number of exceedances not to occur on more than one calendar day per year.

TABLE 28. DAILY AVERAGES FOR JUN 1 1980 THRU JUN 30 1980

SULFUR DIOXIDE (UG/M**3)

HYDROGEN SULFIDE (UG/M**3)

METHANE ((UG/M**3)X10**-1)

SITE
DATE

033

033

033

SITE DATE	033	033	033
JUN 01	0.0	0.0	98.1
JUN 02	0.0	0.0	97.3
JUN 03	0.0	0.0	98.4
JUN 04	0.0	0.0	97.5
JUN 05	0.0	0.2	96.7
JUN 06	0.0	0.0	94.6
JUN 07	0.0	0.0	94.6
JUN 08	0.1	0.0	100.4
JUN 09	0.0	0.0	116.7
JUN 10	0.0	0.0	118.8
JUN 11	0.0	0.0	150.3
JUN 12	0.0	0.0	120.2
JUN 13	0.0	0.0	118.1
JUN 14	0.0	0.0	100.2
JUN 15	0.0	0.0	92.7
JUN 16	0.0	0.0	92.4
JUN 17	0.0	0.0	92.4
JUN 18	0.0	0.0	93.2
JUN 19	0.0	0.0	92.7
JUN 20	0.0	0.0	93.7
JUN 21	0.0	0.0	101.4
JUN 22	0.0	0.0	101.6
JUN 23	0.0	0.0	93.4
JUN 24	0.0	0.0	92.9
JUN 25	0.0	0.0	94.8
JUN 26	0.0	0.0	96.6
JUN 27	0.0	0.0	97.4
JUN 28	0.0	0.0	94.1
JUN 29	0.0	0.0	94.2
JUN 30	0.0	0.1	96.0
JUN 01 -30	0.0	0.0	100.5

TABLE 28. DAILY AVERAGES FOR JUN 1 1980 THRU JUN 30 1980 (cont.)

132

TOTAL SUSPENDED PARTICULATE(UG/M**3)

SITE	033
DATE	
JUN 01	
JUN 02	57.0
JUN 03	
JUN 04	
JUN 05	41.0
JUN 06	
JUN 07	
JUN 08	44.0
JUN 09	
JUN 10	
JUN 11	79.0
JUN 12	
JUN 13	
JUN 14	55.0
JUN 15	
JUN 16	40.0
JUN 17	
JUN 18	
JUN 19	
JUN 20	62.0
JUN 21	
JUN 22	
JUN 23	60.0
JUN 24	
JUN 25	
JUN 26	50.0
JUN 27	43.0
JUN 28	
JUN 29	122.0
JUN 30	
JUN 01 -30	56.1

TABLE 29. THE FIVE MAXIMUM INDEPENDENT SLIDING AVERAGES FOR JUN 1, 1980 - JUN 30, 1980

SULFUR DIOXIDE (UG/M**3)
3-HOUR

SITE	033
1.	6/ 8(5:00- 8:00) 1.0
2.	6/ 1(1:00- 4:00) 0.0
3.	6/ 1(5:00- 8:00) 0.0
4.	6/ 1(8:00-11:00) 0.0
5.	6/ 1(11:00-14:00) 0.0

SULFUR DIOXIDE (UG/M**3)
24-HOUR

SITE	033
1.	6/ 7(6:00- 6:00) 0.1
2.	6/ 1(0:00- 0:00) 0.0
3.	6/ 2(0:00- 0:00) 0.0
4.	6/ 3(0:00- 0:00) 0.0
5.	6/ 4(13:00-13:00) 0.0

TOTAL SUSPENDED PARTICULATE (UG/M**3)
24-HOUR

SITE	033
1.	6/29(0:00- 0:00) 122.0
2.	6/11(0:00- 0:00) 79.0
3.	6/20(0:00- 0:00) 62.0
4.	6/23(0:00- 0:00) 60.0
5.	6/ 2(0:00- 0:00) 57.0

TABLE 29. THE FIVE MAXIMUM INDEPENDENT SLIDING AVERAGES FOR JUN 1, 1980 - JUN 30, 1980
(cont.)HYDROGEN SULFIDE (UG/M**3)
1-HOUR

SITE	033
1.	6/30(14:00-15:00) 3.0
2.	6/ 5(17:00-18:00) 1.0
3.	6/ 5(20:00-21:00) 1.0
4.	6/ 5(21:00-22:00) 1.0
5.	6/ 3(13:00-14:00) 1.0

METHANE ((UG/M**3) X 10**-1)
6-9 AM

SITE	033
1.	6/11(6:00- 9:00) 284.3
2.	6/13(6:00- 9:00) 168.3
3.	6/12(6:00- 9:00) 140.6
4.	6/10(6:00- 9:00) 125.6
5.	6/ 9(6:00- 9:00) 125.3

SULFUR DIOXIDE (UG/M**3)
1-HOUR

SITE	033
1.	6/ 8(5:00- 6:00) 3.0
2.	6/ 1(1:00- 2:00) 0.0
3.	6/ 1(2:00- 3:00) 0.0
4.	6/ 1(3:00- 4:00) 0.0
5.	6/ 1(0:00- 1:00) 0.0

TABLE 30. HOURLY AVERAGES OF SULFUR DIOXIDE (UG/M**3)
 TRAILER NO. - 33 PERIOD(6/ 1/80 TO 6/30/80)

DAY	HOUR																								MEAN
	1	2	3	4	5	6	7	8	9	10	11	12	13	14	15	16	17	13	19	20	21	22	23	24	
1	0	0	0	0	:	0	0	0	0	0	0	0	0	0	0	0	0	0	0	0	0	0	0	0	0
2	0	0	0	0	:	0	0	0	0	0	0	0	0	0	0	0	0	0	0	0	0	0	0	0	0
3	0	0	0	0	:	0	0	0	0	0	0	0	0	0	0	0	0	0	0	0	0	0	0	0	0
4	0	0	0	0	:	0	0	0	0	0	:	:	:	0	0	0	0	0	0	0	0	0	0	0	0
5	0	0	0	0	:	0	0	0	0	0	:	0	0	0	0	0	0	0	0	0	0	0	0	0	0
6	0	0	0	0	:	0	0	0	0	0	0	0	0	0	0	0	0	0	0	0	0	0	0	0	0
7	0	0	0	0	:	0	0	0	0	0	0	0	0	0	0	0	0	0	0	0	0	0	0	0	0
8	0	0	0	0	:	3	0	0	0	0	0	0	0	0	0	0	0	0	0	0	0	0	0	0	0
9	0	0	0	0	:	0	0	0	0	0	0	0	0	0	0	0	0	0	0	0	0	0	0	0	0
10	0	0	0	0	:	0	0	0	0	0	0	0	0	0	0	0	0	0	0	0	0	0	0	0	0
11	0	0	0	0	:	0	0	0	0	0	0	0	0	0	0	0	0	0	0	0	0	0	0	0	0
12	0	0	0	0	:	0	0	0	0	0	0	0	0	0	0	0	0	0	0	0	0	0	0	0	0
13	0	0	0	0	:	0	0	0	0	0	0	0	0	0	0	0	0	0	0	0	0	0	0	0	0
14	0	0	0	0	:	0	0	0	0	0	0	0	0	0	0	0	0	0	0	0	0	0	0	0	0
15	0	0	0	0	:	0	0	0	0	0	0	0	0	0	0	0	0	0	0	0	0	0	0	0	0
16	0	0	0	0	:	0	0	0	0	0	0	0	0	0	0	0	0	0	0	0	0	0	0	0	0
17	0	0	0	0	:	0	0	0	0	0	0	0	0	0	0	0	0	0	0	0	0	0	0	0	0
18	0	0	0	0	:	0	0	0	0	0	0	0	0	0	0	0	0	0	0	0	0	0	0	0	0
19	0	0	0	0	:	0	0	0	0	0	0	0	0	0	0	0	0	0	0	0	0	0	0	0	0
20	0	0	0	0	:	0	0	0	0	0	0	0	0	0	0	0	0	0	0	0	0	0	0	0	0
21	0	0	0	0	:	0	0	0	0	0	0	0	0	0	0	0	0	0	0	0	0	0	0	0	0
22	0	0	0	0	:	0	0	0	0	0	0	0	0	0	0	0	0	0	0	0	0	0	0	0	0
23	0	0	0	0	:	0	0	0	0	0	0	0	0	0	0	0	0	0	0	0	0	0	0	0	0
24	0	0	0	0	:	0	0	0	0	0	0	0	0	0	0	0	0	0	0	0	0	0	0	0	0
25	0	0	0	0	:	0	0	0	0	0	0	0	0	0	0	0	0	0	0	0	0	0	0	0	0
26	0	0	0	0	:	0	0	0	0	0	0	0	0	0	0	0	0	0	0	0	0	0	0	0	0
27	0	0	0	0	:	0	0	0	0	0	0	0	0	0	0	0	0	0	0	0	0	0	0	0	0
28	0	0	0	0	:	0	0	0	0	0	0	0	0	0	0	0	0	0	0	0	0	0	0	0	0
29	0	0	0	0	:	0	0	0	0	0	0	0	0	0	0	0	0	0	0	0	0	0	0	0	0
30	0	0	0	0	:	0	0	0	0	0	0	0	0	0	0	0	0	0	0	0	0	0	0	0	0
MEAN	0	0	0	0		0	0	0	0	0	0	0	0	0	0	0	0	0	0	0	0	0	0	0	0

TOTAL NUMBER OF OBSERVATIONS = 686 MEAN = 0.0
 : INDICATES CALIBRATION FOR THE HOUR

TABLE 30. HOURLY AVERAGES OF HYDROGEN SULFIDE (UG/M**3) (cont.)
 TRAILER NO. - 33 PERIOD(6/ 1/80 TO 6/30/80)

DAY	HOUR																								MEAN
	1	2	3	4	5	6	7	8	9	10	11	12	13	14	15	16	17	18	19	20	21	22	23	24	
1	0	0	0	0	:	0	0	0	0	0	0	0	0	0	0	0	0	0	0	0	0	0	0	0	0
2	0	0	0	0	:	0	0	0	0	0	0	0	0	0	0	0	0	0	0	0	0	0	0	0	0
3	0	0	0	0	:	0	0	0	0	0	0	0	0	1	0	0	0	0	0	0	0	0	0	0	0
4	0	0	0	0	:	0	0	0	0	0	0	0	0	:	:	0	0	0	0	0	0	0	0	0	0
5	0	0	0	0	:	0	0	0	0	0	0	:	0	0	0	0	1	0	0	1	1	1	0	0	0
6	0	0	0	0	:	0	0	0	0	0	0	0	0	0	0	0	0	0	0	0	0	0	0	0	0
7	0	0	0	0	:	0	0	0	0	0	0	0	0	0	0	0	0	0	0	0	0	0	0	0	0
8	0	0	0	0	:	0	0	0	0	0	0	0	0	0	0	0	0	0	0	0	0	0	0	0	0
9	0	0	0	0	:	0	0	0	0	0	0	0	0	0	0	0	0	0	0	0	0	0	0	0	0
10	0	0	0	0	:	0	0	0	0	0	0	0	0	0	0	0	0	0	0	0	0	0	0	0	0
11	0	0	0	0	:	0	0	0	0	0	0	0	0	0	0	0	0	0	0	0	0	0	0	0	0
12	0	0	0	0	:	0	0	0	0	0	0	0	0	0	0	0	0	0	0	0	0	0	0	0	0
13	0	0	0	0	:	0	0	0	0	0	0	0	0	0	0	0	0	0	0	0	0	0	0	0	0
14	0	0	0	0	:	0	0	0	0	0	0	0	0	0	0	0	0	0	0	0	0	0	0	0	0
15	0	0	0	0	:	0	0	0	0	0	0	0	0	0	0	0	0	0	0	0	0	0	0	0	0
16	0	0	0	0	:	0	0	0	0	0	0	0	0	0	0	0	0	0	0	0	0	0	0	0	0
17	0	0	0	0	:	0	0	0	0	0	0	0	0	0	0	0	0	0	0	0	0	0	0	0	0
18	0	0	0	0	:	0	0	0	0	0	0	0	0	0	0	0	0	0	0	0	0	0	0	0	0
19	0	0	0	0	:	0	0	0	0	0	0	0	0	0	0	0	0	0	0	0	0	0	0	0	0
20	0	0	0	0	:	0	0	0	0	0	0	0	0	0	0	0	0	0	0	0	0	0	0	0	0
21	0	0	0	0	:	0	0	0	0	0	0	0	0	0	0	0	0	0	0	0	0	0	0	0	0
22	0	0	0	0	:	0	0	0	0	0	0	0	0	0	0	0	0	0	0	0	0	0	0	0	0
23	0	0	0	0	:	0	0	0	0	0	0	0	0	0	0	0	0	0	0	0	0	0	0	0	0
24	0	0	0	0	:	0	0	0	0	0	0	0	0	0	0	0	0	0	0	0	0	0	0	0	0
25	0	0	0	0	:	0	0	0	0	0	0	0	0	0	0	0	0	0	0	0	0	0	0	0	0
26	0	0	0	0	:	0	0	0	0	0	0	0	0	0	0	0	0	0	0	0	0	0	0	0	0
27	0	0	0	0	:	0	0	0	0	0	0	0	0	0	0	0	0	0	0	0	0	0	0	0	0
28	0	0	0	0	:	0	0	0	0	0	0	0	0	0	0	0	0	0	0	0	0	0	0	0	0
29	0	0	0	0	:	0	0	0	0	0	0	0	0	0	0	0	0	0	0	0	0	0	0	0	0
30	0	0	0	0	:	0	0	0	0	0	0	0	0	0	0	0	0	0	0	0	0	0	0	0	0
MEAN	0	0	0	0		0	0	0	0	0	0	0	0	0	0	0	0	0	0	0	0	0	0	0	0

TOTAL NUMBER OF OBSERVATIONS = 687 MEAN = 0.0
 : INDICATES CALIBRATION FOR THE HOUR

TABLE 30. HOURLY AVERAGES OF METHANE((UG/M**3) X 10**-1) (cont.)
 TRAILER NO. - 33 PERIOD(6/ 1/80 TO 6/30/80)

DAY	HOUR																								MEAN
	1	2	3	4	5	6	7	8	9	10	11	12	13	14	15	16	17	18	19	20	21	22	23	24	
1	99	99	99	99	:	98	99	99	98	98	98	98	98	98	97	97	97	97	98	98	98	98	98	98	98
2	98	98	98	97	:	98	98	98	97	97	97	97	97	97	97	97	97	97	96	97	97	98	99	97	97
3	97	97	97	97	:	98	97	98	98	97	97	97	97	98	98	97	98	99	98	101	102	102	103	100	98
4	98	99	99	101	:	109	106	99	97	97	97	97	95	95	94	94	94	94	:	95	96	96	96	97	98
5	99	99	99	97	:	98	100	108	99	99	98	98	95	95	94	94	94	94	94	94	94	94	94	94	97
6	95	95	95	95	:	96	95	95	95	95	95	95	95	94	94	94	94	94	94	94	94	94	94	94	95
7	94	95	95	95	:	95	95	95	95	95	95	95	94	94	94	94	94	94	94	94	94	94	95	95	96
8	95	97	99	98	:	110	127	117	116	98	95	96	96	95	95	96	95	95	96	96	96	99	101	102	100
9	109	109	117	119	:	129	125	124	127	120	115	114	107	106	116	109	108	111	112	115	118	121	123	129	117
10	131	132	145	136	:	122	130	128	119	114	114	110	109	109	112	110	111	111	109	110	114	119	118	119	119
11	134	133	122	122	:	160	281	328	244	183	149	119	111	111	113	118	123	121	125	127	129	127	137	139	150
12	148	144	133	135	:	147	138	147	137	117	119	112	:	113	103	100	100	100	102	103	100	108	128	111	120
13	106	102	107	108	140	139	167	180	158	134	110	102	100	99	103	103	101	100	102	104	110	129	120	111	118
14	116	119	119	104	115	102	100	99	98	97	97	96	96	96	96	95	95	94	95	95	96	95	95	94	100
15	94	92	91	91	109	96	100	99	93	91	91	91	91	90	90	90	90	91	91	91	91	91	91	91	93
16	90	90	90	91	109	93	93	93	93	92	92	92	92	92	92	92	92	91	92	91	91	91	92	91	92
17	92	91	92	93	112	96	93	93	92	91	91	91	91	91	91	91	91	90	90	90	90	93	92	91	92
18	100	95	94	96	111	96	97	97	94	92	91	91	90	90	90	90	90	90	90	90	90	90	91	92	93
19	92	91	93	91	109	96	97	97	93	92	91	91	91	90	90	90	90	90	90	90	90	90	92	99	93
20	98	93	93	96	119	96	95	102	97	94	92	92	92	91	90	90	90	90	90	89	90	89	90	91	94
21	94	93	94	100	128	113	115	120	117	107	99	97	97	99	95	91	92	93	94	94	96	98	102	106	101
22	117	129	148	137	133	107	97	97	100	98	93	92	92	91	91	91	91	91	90	90	90	90	92	92	102
23	92	92	99	102	116	94	95	94	93	92	91	92	91	91	91	91	90	90	90	90	90	91	92	92	93
24	92	93	92	92	110	94	96	96	95	92	91	92	91	91	90	90	90	90	91	91	91	93	93	93	93
25	93	100	96	92	111	95	95	102	98	92	93	97	93	91	92	93	92	91	91	92	91	93	95	100	95
26	106	109	101	99	112	95	95	104	104	94	92	92	93	93	93	93	92	91	95	93	93	93	95	92	97
27	94	93	92	95	110	93	96	99	95	93	92	93	92	92	91	91	90	91	91	92	92	91	91	93	93
28	93	97	98	95	111	96	96	98	98	93	91	91	91	91	91	91	90	90	91	91	93	98	93	94	94
29	97	94	95	93	110	95	96	97	98	95	94	92	92	92	91	91	91	91	91	91	92	93	95	95	94
30	96	97	97	97	115	105	104	104	107	96	92	92	91	91	86	91	91	91	90	91	91	93	104	96	96
MEAN	102	102	103	102	116	105	111	113	108	102	98	97	95	96	95	95	95	95	96	96	97	98	100	100	

TOTAL NUMBER OF OBSERVATIONS = 706 MEAN = 100.5
 : INDICATES CALIBRATION FOR THE HOUR

XII. JULY METHANE BAG SAMPLING PROGRAM

Grab-bag samples are collected bi-weekly and analyzed for methane. The ambient air samples are collected in tedlar bags using a metal bellows pump connected to the ambient sample manifold. Each bag sample is collected over a three-hour period.

The bag samples are returned to Austin for analysis for methane concentration. The analysis is performed on either a Bendix 8202 or a Baseline Industries Model 1030 gas chromatograph using a flame ionization detector. The minimum detectable limit using this technique is less than 1 ppm.

Results of the bag sampling analyses are given below:

<u>Date</u>	<u>Time</u>	<u>Methane Concentration (ppm)</u>
7/8/80	0600-0900	1.88
7/24/80	0600-0900	3.03

TABLE 31.
DOWNTIME HOURS FOR CHOCOLATE BAYOU, TEXAS, 1980
(JULY)

SITE 033 DIGITIZING		SO2	H2S	CH4	TSP
7/ 1	10	0	0	0	-
7/ 2	24	0	0	0	24
7/ 3	12	0	0	0	-
7/ 4	0	0	0	0	-
7/ 5	0	0	0	0	0
7/ 6	0	0	0	0	-
7/ 7	0	0	0	0	-
7/ 8	0	0	0	0	0
7/ 9	0	0	0	0	-
7/10	0	0	0	0	-
7/11	0	0	0	0	0
7/12	0	0	0	0	-
7/13	0	0	0	0	-
7/14	0	0	0	0	0
7/15	0	0	0	0	-
7/16	0	0	0	0	-
7/17	0	0	0	0	0
7/18	0	0	0	0	-
7/19	0	0	0	0	-
7/20	0	0	0	0	0
7/21	0	0	0	0	-
7/22	0	0	0	0	-
7/23	0	0	0	0	0
7/24	0	0	0	0	-
7/25	0	0	0	0	-
7/26	0	0	0	0	0
7/27	0	0	0	0	-
7/28	0	0	0	0	-
7/29	0	0	0	0	0
7/30	0	0	0	0	-
7/31	0	0	0	0	-
CAL TIME		31	32	31	
DATA CAPTURE RATE (%)		94	94	94	94

Downtime Summary for July 1980

During July, the data capture rates for all parameters were 90 percent or better. The only data losses occurred during July 1-3, when a faulty power supply to the DART II data acquisition system caused 46 hours of downtime.

TABLE 32.

FEDERAL AND TEXAS STATE AMBIENT AIR QUALITY STANDARDS (JULY)

Agency	Pollutant	Special Conditions		$\mu\text{g}/\text{m}^3$ Primary	(PPM)	$\mu\text{g}/\text{m}^3$ Secondary	(PPM)
Federal and Texas	SO ₂		Annual	80	.03		
			24-Hour*	365	.14		
			3-Hour*	---		1300	.5
Texas	SO ₂	All Counties Except Harris, Galveston Orange, Jefferson	30-Minute**	1061	.4	----	
			30-Minute**	743	.28	----	
			30-Minute**	849	.32	----	
Federal and Texas	Particulate		Annual***	75		60	
			24-Hour*	260		150	
Texas	Particulate		5-Hour**	100		---	
			3-Hour**	200		---	
			1-Hour**	400		---	
Federal and Texas	CO		8-Hour*	10,000	9.	10,000	9.
			1-Hour*	40,000	35.	40,000	35.
Federal and Texas	Ozone HC (Non-Methane) NO ₂	6-9 a.m.	1-Hour†	235	.12	235	.12
			3-Hour*	160	.24	160	.24
			Annual	100	.05	100	.05

*Not to be exceeded more than once per year.

**Texas special regulations. Single plant source may not exceed these ambient levels in Texas at any point, at any time.

***Geometric Mean.

†The expected number of exceedances not to occur on more than one calendar day per year.

CORPORATION

TABLE 33. DAILY AVERAGES FOR JUL 1 1980 THRU JUL 31 1982

142

SITE DATE	SULFUR DIOXIDE (UG/M**3)	HYDROGEN SULFIDE (UG/M**3)	METHANE ((UG/M**3)X10**-1)
	033	033	033
JUL 01	0.0	0.0	98.0
JUL 02			
JUL 03	0.0	0.0	95.9
JUL 04	0.0	0.0	98.3
JUL 05	0.0	0.0	103.3
JUL 06	0.0	0.0	112.4
JUL 07	0.0	0.0	93.5
JUL 08	0.0	0.0	100.4
JUL 09	0.0	0.0	104.0
JUL 10	0.0	0.0	104.5
JUL 11	0.0	0.0	105.7
JUL 12	0.0	0.0	102.5
JUL 13	0.0	0.0	100.5
JUL 14	0.0	0.3	99.7
JUL 15	0.0	0.0	97.7
JUL 16	0.0	0.0	105.5
JUL 17	0.0	0.0	106.8
JUL 18	0.0	0.0	112.4
JUL 19	0.0	0.0	119.7
JUL 20	0.0	0.0	99.1
JUL 21	0.0	0.0	96.1
JUL 22	0.0	0.0	106.5
JUL 23	0.0	0.0	130.0
JUL 24	0.0	0.0	113.9
JUL 25	0.0	0.1	112.4
JUL 26	0.0	0.0	93.7
JUL 27	0.0	0.0	96.3
JUL 28	0.0	0.0	101.7
JUL 29	0.0	0.0	117.5
JUL 30	0.0	0.0	99.3
JUL 31	0.0	0.0	102.7
JUL 01 -31	0.0	0.0	104.5

TABLE 33. DAILY AVERAGES FOR JUL 1 1980 THRU JUL 31 1980 (cont.)

TOTAL SUSPENDED PARTICULATE (UG/M**3)

SITE	033
DATE	
JUL 01	
JUL 02	
JUL 03	
JUL 04	
JUL 05	56.0
JUL 06	
JUL 07	
JUL 08	45.0
JUL 09	
JUL 10	
JUL 11	72.0
JUL 12	
JUL 13	
JUL 14	54.0
JUL 15	
JUL 16	
JUL 17	94.0
JUL 18	
JUL 19	
JUL 20	43.0
JUL 21	
JUL 22	
JUL 23	31.0
JUL 24	
JUL 25	
JUL 26	23.0
JUL 27	
JUL 28	
JUL 29	67.0
JUL 30	
JUL 31	
JUL 01 -31	49.8

TABLE 34. THE FIVE MAXIMUM INDEPENDENT SLIDING AVERAGES FOR JUL 1, 1980 - JUL 31, 1980

SULFUR DIOXIDE (UG/M**3)
3-HOUR

ITE 033

1.	7/ 1(0:00- 3:00)	0.0
2.	7/ 1(5:00- 8:00)	0.0
3.	7/ 1(8:00-11:00)	0.0
4.	7/ 3(12:00-15:00)	0.0
5.	7/ 3(15:00-18:00)	0.0

SULFUR DIOXIDE (UG/M**3)
24-HOUR

ITE 033

1.	7/ 3(11:00-11:00)	0.0
2.	7/ 4(11:00-11:00)	0.0
3.	7/ 5(11:00-11:00)	0.0
4.	7/ 6(11:00-11:00)	0.0
5.	7/ 7(11:00-11:00)	0.0

TOTAL SUSPENDED PARTICULATE (UG/M**3)
24-HOUR

ITE 033

1.	7/17(0:00- 0:00)	94.0
2.	7/11(0:00- 0:00)	72.0
3.	7/29(0:00- 0:00)	67.0
4.	7/ 5(0:00- 0:00)	56.0
5.	7/14(0:00- 0:00)	54.0

CORPORATION

TABLE 34. THE FIVE MAXIMUM INDEPENDENT SLIDING AVERAGES FOR JUL 1, 1980 - JUL 31, 1983
(cont.)HYDROGEN SULFIDE (UG/M**3)
1-HOUR

SITE 033

1.	7/14(11:00-12:00)	7.0
2.	7/25(13:00-14:00)	3.0
3.	7/ 1(2:00- 3:00)	0.3
4.	7/ 1(3:00- 4:00)	0.0
5.	7/ 1(1:00- 2:00)	0.0

METHANE ((UG/M**3)X10**-1)
6-9 AM

SITE 033

1.	7/23(6:00- 9:00)	199.0
2.	7/25(6:00- 9:00)	174.0
3.	7/ 6(6:00- 9:00)	165.6
4.	7/19(6:00- 9:00)	165.0
5.	7/29(5:00- 9:00)	141.5

SULFUR DIOXIDE (UG/M**3)
1-HOUR

SITE 033

1.	7/ 1(0:00- 1:00)	2.0
2.	7/ 1(1:00- 2:00)	2.0
3.	7/ 1(2:00- 3:00)	0.0
4.	7/ 1(3:00- 4:00)	0.2
5.	7/ 1(5:00- 6:00)	3.0

CORPORATION

TABLE 35. HOURLY AVERAGES OF SULFUR DIOXIDE (UG/M**3)
TRAILER NO. - 33 PERIOD(7/ 1/82 TO 7/31/82)

146

DAY	HOUR																								MEAN
	1	2	3	4	5	6	7	8	9	10	11	12	13	14	15	16	17	18	19	20	21	22	23	24	
1	0	0	0	0	:	0	0	0	0	0	0	0	0											0	
2	0	0	0	0	:	0	0	0	0	0	0	0	0	0	0	0	0	0	0	0	0	0	0	0	0
3	0	0	0	0	:	0	0	0	0	0	0	0	0	0	0	0	0	0	0	0	0	0	0	0	0
4	0	0	0	0	:	0	0	0	0	0	0	0	0	0	0	0	0	0	0	0	0	0	0	0	0
5	0	0	0	0	:	0	0	0	0	0	0	0	0	0	0	0	0	0	0	0	0	0	0	0	0
6	0	0	0	0	:	0	0	0	0	0	0	0	0	0	0	0	0	0	0	0	0	0	0	0	0
7	0	0	0	0	:	0	0	0	0	0	0	0	0	0	0	0	0	0	0	0	0	0	0	0	0
8	0	0	0	0	:	0	0	0	0	0	0	0	0	0	0	0	0	0	0	0	0	0	0	0	0
9	0	0	0	0	:	0	0	0	0	0	0	0	0	0	0	0	0	0	0	0	0	0	0	0	0
10	0	0	0	0	:	0	0	0	0	0	0	0	0	0	0	0	0	0	0	0	0	0	0	0	0
11	0	0	0	0	:	0	0	0	0	0	0	0	0	0	0	0	0	0	0	0	0	0	0	0	0
12	0	0	0	0	:	0	0	0	0	0	0	0	0	0	0	0	0	0	0	0	0	0	0	0	0
13	0	0	0	0	:	0	0	0	0	0	0	0	0	0	0	0	0	0	0	0	0	0	0	0	0
14	0	0	0	0	:	0	0	0	0	0	0	0	0	0	0	0	0	0	0	0	0	0	0	0	0
15	0	0	0	0	:	0	0	0	0	0	0	0	0	0	0	0	0	0	0	0	0	0	0	0	0
16	0	0	0	0	:	0	0	0	0	0	0	0	0	0	0	0	0	0	0	0	0	0	0	0	0
17	0	0	0	0	:	0	0	0	0	0	0	0	0	0	0	0	0	0	0	0	0	0	0	0	0
18	0	0	0	0	:	0	0	0	0	0	0	0	0	0	0	0	0	0	0	0	0	0	0	0	0
19	0	0	0	0	:	0	0	0	0	0	0	0	0	0	0	0	0	0	0	0	0	0	0	0	0
20	0	0	0	0	:	0	0	0	0	0	0	0	0	0	0	0	0	0	0	0	0	0	0	0	0
21	0	0	0	0	:	0	0	0	0	0	0	0	0	0	0	0	0	0	0	0	0	0	0	0	0
22	0	0	0	0	:	0	0	0	0	0	0	0	0	0	0	0	0	0	0	0	0	0	0	0	0
23	0	0	0	0	:	0	0	0	0	0	0	0	0	0	0	0	0	0	0	0	0	0	0	0	0
24	0	0	0	0	:	0	0	0	0	0	0	0	0	0	0	0	0	0	0	0	0	0	0	0	0
MEAN	0	0	0	0	:	0	0	0	0	0	0	0	0	0	0	0	0	0	0	0	0	0	0	0	0

TOTAL NUMBER OF OBSERVATIONS = 667 MEAN = 0.0
: INDICATES CALIBRATION FOR THE HOUR

CORPORATION

TABLE 35. HOURLY AVERAGES OF HYDROGEN SULFIDE (UG/M**3) (cont.)
 TRAILER NO. - 33 PERIOD(7/ 1/80 TO 7/31/80)

DAY	HOUR																								MEAN
	1	2	3	4	5	6	7	8	9	10	11	12	13	14	15	16	17	18	19	20	21	22	23	24	
1	0	0	0	0	:	0	0	0	0	0	0	0	0											0	
2																									
3													0	0	0	0	0	0	0	0	0	0	0	0	0
4	0	0	0	0	:	0	0	0	0	0	0	0	0	0	0	0	0	0	0	0	0	0	0	0	0
5	0	0	0	0	:	0	0	0	0	0	0	0	0	0	0	0	0	0	0	0	0	0	0	0	0
6	0	0	0	0	:	0	0	0	0	0	0	0	0	0	0	0	0	0	0	0	0	0	0	0	0
7	0	0	0	0	:	0	0	0	0	0	0	0	0	0	0	0	0	0	0	0	0	0	0	0	0
8	0	0	0	0	:	0	0	0	0	0	0	0	0	0	0	0	0	0	0	0	0	0	0	0	0
9	0	0	0	0	:	0	0	0	0	0	0	0	0	0	0	0	0	0	0	0	0	0	0	0	0
10	0	0	0	0	:	0	0	0	0	0	0	0	0	0	0	0	0	0	0	0	0	0	0	0	0
11	0	0	0	0	:	0	0	0	0	0	0	0	0	0	0	0	0	0	0	0	0	0	0	0	0
12	0	0	0	0	:	0	0	0	0	0	0	0	0	0	0	0	0	0	0	0	0	0	0	0	0
13	0	0	0	0	:	0	0	0	0	0	0	0	0	0	0	0	0	0	0	0	0	0	0	0	0
14	0	0	0	0	:	0	0	0	0	0	0	0	0	0	0	0	0	0	0	0	0	0	0	0	0
15	0	0	0	0	:	0	0	0	0	0	0	0	0	0	0	0	0	0	0	0	0	0	0	0	0
16	0	0	0	0	:	0	0	0	0	0	0	0	0	0	0	0	0	0	0	0	0	0	0	0	0
17	0	0	0	0	:	0	0	0	0	0	0	0	0	0	0	0	0	0	0	0	0	0	0	0	0
18	0	0	0	0	:	0	0	0	0	0	0	0	0	0	0	0	0	0	0	0	0	0	0	0	0
19	0	0	0	0	:	0	0	0	0	0	0	0	0	0	0	0	0	0	0	0	0	0	0	0	0
20	0	0	0	0	:	0	0	0	0	0	0	0	0	0	0	0	0	0	0	0	0	0	0	0	0
21	0	0	0	0	:	0	0	0	0	0	0	0	0	0	0	0	0	0	0	0	0	0	0	0	0
22	0	0	0	0	:	0	0	0	0	0	0	0	0	0	0	0	0	0	0	0	0	0	0	0	0
23	0	0	0	0	:	0	0	0	0	0	0	0	0	0	0	0	0	0	0	0	0	0	0	0	0
24	0	0	0	0	:	0	0	0	0	0	0	0	0	0	0	0	0	0	0	0	0	0	0	0	0
MEAN	0	0	0	0	:	0	0	0	0	0	0	0	0	0	0	0	0	0	0	0	0	0	0	0	0

TOTAL NUMBER OF OBSERVATIONS = 566 MEAN = 0.2
 : INDICATES CALIBRATION FOR THE HOUR

CORPORATION

TABLE 35. HOURLY AVERAGES OF METHANE (CO₂/M³)*X10³-1 (cont.)
TRAILER NO. - 33 PERIOD (7/1/80 TO 7/31/80)

AY	HOUR																								MFA		
	1	2	3	4	5	6	7	8	9	10	11	12	13	14	15	16	17	18	19	20	21	22	23	24			
1	97	95	96	103	:	98	102	102	100	97	95	93	92											104			
2																											
3													116	96	94	94	93	94	94	94	94	94	94	94	94		
4	95	94	102	108	:	105	104	109	114	99	97	96	95	95	95	95	95	94	94	95	95	95	95	95	95		
5	99	103	107	104	:	120	119	118	122	108	99	98	97	97	97	97	98	98	98	99	99	101	99	98	100		
6	99	99	99	101	:	165	156	175	166	122	113	103	101	100	97	97	97	98	98	98	98	103	104	97	97	11	
7	99	98	100	97	:	94	93	93	93	92	92	92	92	92	92	92	91	91	91	92	92	93	94	94	94	9	
8	93	92	92	96	:	118	116	126	133	105	97	102	97	95	96	95	93	92	92	91	92	92	97	102	98	10	
9	115	121	109	102	:	101	115	132	151	109	97	97	96	95	95	94	94	94	93	94	95	96	98	100	100	10	
10	107	116	117	117	:	120	128	145	123	106	95	95	97	95	94	94	94	92	91	92	93	98	98	97	100	10	
11	96	107	104	116	:	119	121	124	139	121	99	106	103	101	99	96	95	95	95	95	96	99	101	103	100	10	
12	107	109	103	104	:	113	117	123	120	108	98	100	97	95	94	93	93	93	93	93	95	100	102	107	100	10	
13	103	100	105	105	:	117	111	114	105	100	99	99	97	95	93	95	95	95	95	95	96	97	97	99	100	10	
14	105	106	108	97	:	108	114	118	110	105	98	95	94	93	93	92	92	92	92	93	94	96	99	100	100	10	
15	100	99	104	105	:	101	101	116	112	96	94	93	93	92	92	93	93	93	93	94	95	95	95	97	9	9	
16	100	113	111	115	:	117	116	128	154	105	101	104	102	100	98	97	95	93	93	94	94	97	99	100	100	10	
17	116	136	114	108	:	123	129	129	119	110	101	99	99	96	95	95	98	99	98	97	98	101	99	97	100	10	
18	100	105	114	131	:	129	126	116	115	114	99	97	97	97	99	104	103	102	99	114	121	117	140	143	11	11	
19	122	120	128	123	:	183	173	167	155	148	124	110	102	100	97	96	95	94	98	96	97	101	102	100	100	11	
20	112	108	124	106	:	103	102	103	102	102	97	98	98	98	99	97	93	95	94	94	93	93	93	93	93	9	
21	93	93	93	95	:	103	97	97	97	98	97	95	94	94	97	97	100	95	93	93	93	93	101	102	100	9	
22	96	96	98	98	:	110	113	113	130	127	111	99	109	106	109	106	104	102	103	107	102	98	122	111	100	10	
23	120	132	169	181	:	240	224	198	175	131	115	105	99	101	101	99	98	98	99	101	102	101	130	102	100	10	
24	105	112	117	118	:	129	143	189			:	133	116	111	103	99	99	99	101	103	104	100	102	103	103	11	
25	105	106	104	106	:	157	176	175	171	165	102	95	96	95	95	95	93	93	94	93	91	92	93	93	93	11	
26	94	94	95	94	:	93	94	96	94	95	97	93	92	92	93	95	93	92	91	91	91	92	92	92	92	9	
27	101	125	98	98	:	99	104	102	95	96	94	93	92	92	93	93	92	92	93	94	94	95	99	93	9	9	
28	95	98	99	101	:	98	99	103	121	119	93	91	95	99	99	102	105	103	95	96	102	106	112	112	10	10	
29	146	145	159	165	:	143	139	135	151	138	121	103	94	93	93	94	106	94	93	93	96	96	101	104	11	11	
30	100	97	99	114	:	121	110	104	101	96	94	96	98	97	96	93	93	92	92	92	92	93	98	101	106	9	9
31	108	101	113	145	:	108	114	114	113	117	106	94	95	92	92	93	93	93	92	92	92	93	94	98	102	10	10
MEAN	104	107	109	112	:	122	123	125	124	112	102	99	98	93	96	96	95	95	95	95	96	97	98	100	102	10	10

TOTAL NUMBER OF OBSERVATIONS = 667

MEAN = 104.5

: INDICATES CALIBRATION FOR THE HOUR

XIII. AUGUST METHANE BAG SAMPLING PROGRAM

Grab-bag samples are collected bi-weekly and analyzed for methane. The ambient air samples are collected in tedlar bags using a metal bellows pump connected to the ambient sample manifold. Each bag sample is collected over a three-hour period.

The bag samples are returned to Austin for analysis for methane concentration. The analysis is performed on either a Bendix 8202 or a Baseline Industries Model 1030 gas chromatograph using a flame ionization detector. The minimum detectable limit using this technique is less than 1 ppm.

Results of the bag sampling analyses are given below:

<u>Date</u>	<u>Time</u>	<u>Methane Concentration (ppm)</u>
8/ 5/80	0600-0900	2.12
8/22/80	0600-0900	2.20

TABLE 36.
 DOWNTIME HOURS FOR CHOCOLATE BAYOU, TEXAS, 1980
 (AUGUST)

SITE 033					
DIGITIZING					
DATE	SYSTEM	SO2	H2S	CH4	TSP
8/ 1	0	0	0	0	0
8/ 2	24	0	0	0	-
8/ 3	24	0	0	0	-
8/ 4	14	0	0	0	24
8/ 5	0	0	0	0	-
8/ 6	0	0	0	0	-
8/ 7	0	0	0	0	0
8/ 8	0	0	1	0	-
8/ 9	0	0	0	0	-
8/10	0	0	0	0	0
8/11	0	0	0	0	-
8/12	0	0	0	0	-
8/13	0	0	0	0	0
8/14	0	0	0	0	-
8/15	0	0	0	0	-
8/16	0	0	0	0	0
8/17	0	0	0	0	-
8/18	0	0	0	0	-
8/19	0	0	0	0	0
8/20	0	0	0	0	-
8/21	0	0	1	0	-
8/22	0	0	0	0	0
8/23	0	0	0	0	-
8/24	0	0	0	0	-
8/25	0	0	0	0	0
8/26	0	0	0	0	-
8/27	0	0	0	0	-
8/28	0	0	0	0	0
8/29	0	0	0	0	-
8/30	0	0	0	0	-
8/31	0	0	0	0	0
CAL TIME		28	28	28	
DATA CAPTURE RATE (%)		92	91	92	91

Downtime Summary for August 1980

During August, as in previous months, the data capture rates for all parameters were 90 percent or better.

The power supply to the DART II data acquisition system, which had caused data losses from July 1-3, failed again at midnight on August 1. It was repaired on August 4 and operated without further problems the rest of the month.

TABLE 37.

FEDERAL AND TEXAS STATE AMBIENT AIR QUALITY STANDARDS (AUGUST)

Agency	Pollutant	Special Conditions		$\mu\text{g}/\text{m}^3$ Primary	(PPM)	$\mu\text{g}/\text{m}^3$ Secondary	(PPM)	
Federal and Texas	SO ₂		Annual	80	.03			
			24-Hour*	365	.14			
			3-Hour*	---		1300	.5	
Texas	SO ₂	All Counties Except	30-Minute**	1061	.4	----		
			Harris, Galveston	30-Minute**	743	.28	----	
				Orange, Jefferson	30-Minute**	849	.32	----
Federal and Texas	Particulate		Annual***	75		60		
			24-Hour*	260		150		
Texas	Particulate		5-Hour**	100		---		
			3-Hour**	200		---		
			1-Hour**	400		---		
Federal and Texas	CO		8-Hour*	10,000	9.	10,000	9.	
			1-Hour*	40,000	35.	40,000	35.	
Federal and Texas	Photochemical Oxidant HC (Non-Methane) NO ₂	6-9 a.m.	1-Hour†	235	.12	235	.12	
			3-Hour*	160	.24	160	.24	
			Annual	100	.05	100	.05	

*Not to be exceeded more than once per year.

**Texas special regulations. Single plant source may not exceed these ambient levels in Texas at any point, at any time.

***Geometric Mean.

†The expected number of exceedances not to occur on more than one calendar day per year.

TABLE 38. DAILY AVERAGES FOR AUG 1 1980 THRU AUG 31 1980

SITE DATE	SULFUR DIOXIDE (UG/M**3)	HYDROGEN SULFIDE (UG/M**3)	METHANE ((UG/M**3)X10**-1)
	033	033	033
AUG 01	0.0	0.0	108.4
AUG 02			
AUG 03			
AUG 04			
AUG 05	0.0	0.0	91.7
AUG 06	0.0	0.0	97.0
AUG 07	0.0	0.0	106.3
AUG 08	0.0	0.0	116.0
AUG 09	0.0	0.0	98.6
AUG 10	0.0	0.0	108.6
AUG 11	0.0	0.0	96.3
AUG 12	0.0	0.0	92.9
AUG 13	0.0	0.0	100.1
AUG 14	0.0	0.0	94.6
AUG 15	0.0	0.0	90.8
AUG 16	0.0	0.0	91.8
AUG 17	0.0	0.0	92.3
AUG 18	0.0	0.0	92.4
AUG 19	0.0	0.0	92.8
AUG 20	0.0	0.0	95.2
AUG 21	0.0	0.0	99.5
AUG 22	0.0	0.0	111.9
AUG 23	0.2	0.0	127.6
AUG 24	0.0	0.0	117.7
AUG 25	0.0	0.0	132.1
AUG 26	0.0	0.0	117.2
AUG 27	0.0	0.0	110.4
AUG 28	0.0	0.0	102.5
AUG 29	0.0	0.0	99.6
AUG 30	0.0	0.0	93.3
AUG 31	0.0	0.0	92.7
AUG 01 -31	0.0	0.0	102.3

TABLE 38. DAILY AVERAGES FOR AUG 1 1980 THRU AUG 31 1980 (cont.)

TOTAL SUSPENDED PARTICULATE(UG/M**3)

SITE	033
DATE	
AUG 01	73.0
AUG 02	
AUG 03	
AUG 04	
AUG 05	
AUG 06	
AUG 07	33.0
AUG 08	
AUG 09	
AUG 10	82.0
AUG 11	
AUG 12	
AUG 13	46.0
AUG 14	
AUG 15	
AUG 16	65.0
AUG 17	
AUG 18	
AUG 19	58.0
AUG 20	
AUG 21	
AUG 22	65.0
AUG 23	
AUG 24	
AUG 25	71.0
AUG 26	
AUG 27	
AUG 28	33.0
AUG 29	
AUG 30	
AUG 31	28.0
AUG 01 -31	52.1

TABLE 39. THE FIVE MAXIMUM INDEPENDENT SLIDING AVERAGES FOR AUG 1, 1980 - AUG 31, 1980

SULFUR DIOXIDE (UG/M**3)
3-HOUR

SITE 033

1. 8/23(8:00-11:00)	1.6
2. 8/ 1(6:00- 9:00)	0.0
3. 8/ 1(9:00-12:00)	0.0
4. 8/ 1(12:00-15:00)	0.0
5. 8/ 1(15:00-18:00)	0.0

SULFUR DIOXIDE (UG/M**3)
24-HOUR

SITE 033

1. 8/22(11:00-11:00)	0.1
2. 8/ 5(11:00-11:00)	0.0
3. 8/ 6(11:00-11:00)	0.0
4. 8/ 7(11:00-11:00)	0.0
5. 8/ 8(11:00-11:00)	0.0

TOTAL SUSPENDED PARTICULATE (UG/M**3)
24-HOUR

SITE 033

1. 8/10(0:00- 0:00)	82.0
2. 8/ 1(0:00- 0:00)	73.0
3. 8/25(0:00- 0:00)	71.0
4. 8/22(0:00- 0:00)	65.0
5. 8/16(0:00- 0:00)	65.0

TABLE 39. THE FIVE MAXIMUM INDEPENDENT SLIDING AVERAGES FOR AUG 1, 1980 - AUG 31, 1980
(cont.)

HYDROGEN SULFIDE (UG/M**3)
1-HOUR

SITE	033	
1.	8/ 1(0:00- 1:00)	0.0
2.	8/ 1(1:00- 2:00)	0.0
3.	8/ 1(2:00- 3:00)	0.0
4.	8/ 1(3:00- 4:00)	0.0
5.	8/ 1(5:00- 6:00)	0.0

METHANE ((UG/M**3)X10**-1)
6-9 AM

SITE	033	
1.	8/25(6:00- 9:00)	213.3
2.	8/23(6:00- 9:00)	188.3
3.	8/26(6:00- 9:00)	180.0
4.	8/27(6:00- 9:00)	157.0
5.	8/ 8(6:00- 9:00)	139.6

SULFUR DIOXIDE (UG/M**3)
1-HOUR

SITE	033	
1.	8/23(10:00-11:00)	5.0
2.	8/ 1(1:00- 2:00)	0.0
3.	8/ 1(2:00- 3:00)	0.0
4.	8/ 1(3:00- 4:00)	0.0
5.	8/ 1(0:00- 1:00)	0.0

TABLE 40. HOURLY AVERAGES OF SULFUR DIOXIDE (UG/M3)
TRAILER NO. - 33 PERIOD(8/ 1/80 TO 8/31/80)**

DAY	HOUR																								MEAN	
	1	2	3	4	5	6	7	8	9	10	11	12	13	14	15	16	17	18	19	20	21	22	23	24		
1	0	0	0	0	:	0	0	0	0	0	0	0	0	0	0	0	0	0	0	0	0	0	0	0	0	
2																										
3																										
4																0	0	0	0	0	0	0	0	0	0	0
5	0	0	0	0	:	0	0	0	0	0	0	0	0	0	0	0	0	0	0	0	0	0	0	0	0	0
6	0	0	0	0	:	0	0	0	0	0	0	0	0	0	0	0	0	0	0	0	0	0	0	0	0	0
7	0	0	0	0	:	0	0	0	0	0	0	0	0	0	0	0	0	0	0	0	0	0	0	0	0	0
8	0	0	0	0	:	0	0	0	0	0	0	0	0	0	0	0	0	0	0	0	0	0	0	0	0	0
9	0	0	0	0	:	0	0	0	0	0	0	0	0	0	0	0	0	0	0	0	0	0	0	0	0	0
10	0	0	0	0	:	0	0	0	0	0	0	0	0	0	0	0	0	0	0	0	0	0	0	0	0	0
11	0	0	0	0	:	0	0	0	0	0	0	0	0	0	0	0	0	0	0	0	0	0	0	0	0	0
12	0	0	0	0	:	0	0	0	0	0	0	0	0	0	0	0	0	0	0	0	0	0	0	0	0	0
13	0	0	0	0	:	0	0	0	0	0	0	0	0	0	0	0	0	0	0	0	0	0	0	0	0	0
14	0	0	0	0	:	0	0	0	0	0	0	0	0	0	0	0	0	0	0	0	0	0	0	0	0	0
15	0	0	0	0	:	0	0	0	0	0	0	0	0	0	0	0	0	0	0	0	0	0	0	0	0	0
16	0	0	0	0	:	0	0	0	0	0	0	0	0	0	0	0	0	0	0	0	0	0	0	0	0	0
17	0	0	0	0	:	0	0	0	0	0	0	0	0	0	0	0	0	0	0	0	0	0	0	0	0	0
18	0	0	0	0	:	0	0	0	0	0	0	0	0	0	0	0	0	0	0	0	0	0	0	0	0	0
19	0	0	0	0	:	0	0	0	0	0	0	0	0	0	0	0	0	0	0	0	0	0	0	0	0	0
20	0	0	0	0	:	0	0	0	0	0	0	0	0	0	0	0	0	0	0	0	0	0	0	0	0	0
21	0	0	0	0	:	0	0	0	0	0	0	0	0	0	0	0	0	0	0	0	0	0	0	0	0	0
22	0	0	0	0	:	0	0	0	0	0	0	0	0	0	0	0	0	0	0	0	0	0	0	0	0	0
23	0	0	0	0	:	0	0	0	0	0	5	0	0	0	0	0	0	0	0	0	0	0	0	0	0	0
24	0	0	0	0	:	0	0	0	0	0	0	0	0	0	0	0	0	0	0	0	0	0	0	0	0	0
25	0	0	0	0	:	0	0	0	0	0	0	0	0	0	0	0	0	0	0	0	0	0	0	0	0	0
26	0	0	0	0	:	0	0	0	0	0	0	0	0	0	0	0	0	0	0	0	0	0	0	0	0	0
27	0	0	0	0	:	0	0	0	0	0	0	0	0	0	0	0	0	0	0	0	0	0	0	0	0	0
28	0	0	0	0	:	0	0	0	0	0	0	0	0	0	0	0	0	0	0	0	0	0	0	0	0	0
29	0	0	0	0	:	0	0	0	0	0	0	0	0	0	0	0	0	0	0	0	0	0	0	0	0	0
30	0	0	0	0	:	0	0	0	0	0	0	0	0	0	0	0	0	0	0	0	0	0	0	0	0	0
31	0	0	0	0	:	0	0	0	0	0	0	0	0	0	0	0	0	0	0	0	0	0	0	0	0	0
MEAN	0	0	0	0		0	0	0	0	0	0	0	0	0	0	0	0	0	0	0	0	0	0	0	0	0

TOTAL NUMBER OF OBSERVATIONS = 654 MEAN = 0.0
: INDICATES CALIBRATION FOR THE HOUR

TABLE 40. HOURLY AVERAGES OF HYDROGEN SULFIDE (UG/M**3) (cont.)
TRAILER NO. - 33 PERIOD(8/ 1/80 TO 8/31/80)

DAY	HOUR																								MEAN
	1	2	3	4	5	6	7	8	9	10	11	12	13	14	15	16	17	18	19	20	21	22	23	24	
1	0	0	0	0	:	0	0	0	0	0	0	0	0	0	0	0	0	0	0	0	0	0	0	0	0
2																									
3																									
4																									
5	0	0	0	0	:	0	0	0	0	0	0	0	0	0	0	0	0	0	0	0	0	0	0	0	0
6	0	0	0	0	:	0	0	0	0	0	0	0	0	0	0	0	0	0	0	0	0	0	0	0	0
7	0	0	0	0	:	0	0	0	0	0	0	0	0	0	0	0	0	0	0	0	0	0	0	0	0
8	0	0	0	0	:	0	0	0	0	0	0	0	0	0	0	0	0	0	0	0	0	0	0	0	0
9	0	0	0	0	:	0	0	0	0	0	0	0	0	0	0	0	0	0	0	0	0	0	0	0	0
10	0	0	0	0	:	0	0	0	0	0	0	0	0	0	0	0	0	0	0	0	0	0	0	0	0
11	0	0	0	0	:	0	0	0	0	0	0	0	0	0	0	0	0	0	0	0	0	0	0	0	0
12	0	0	0	0	:	0	0	0	0	0	0	0	0	0	0	0	0	0	0	0	0	0	0	0	0
13	0	0	0	0	:	0	0	0	0	0	0	0	0	0	0	0	0	0	0	0	0	0	0	0	0
14	0	0	0	0	:	0	0	0	0	0	0	0	0	0	0	0	0	0	0	0	0	0	0	0	0
15	0	0	0	0	:	0	0	0	0	0	0	0	0	0	0	0	0	0	0	0	0	0	0	0	0
16	0	0	0	0	:	0	0	0	0	0	0	0	0	0	0	0	0	0	0	0	0	0	0	0	0
17	0	0	0	0	:	0	0	0	0	0	0	0	0	0	0	0	0	0	0	0	0	0	0	0	0
18	0	0	0	0	:	0	0	0	0	0	0	0	0	0	0	0	0	0	0	0	0	0	0	0	0
19	0	0	0	0	:	0	0	0	0	0	0	0	0	0	0	0	0	0	0	0	0	0	0	0	0
20	0	0	0	0	:	0	0	0	0	0	0	0	0	0	0	0	0	0	0	0	0	0	0	0	0
21	0	0	0	0	:	0	0	0	0	0	0	0	0	0	0	0	0	0	0	0	0	0	0	0	0
22	0	0	0	0	:	0	0	0	0	0	0	0	0	0	0	0	0	0	0	0	0	0	0	0	0
23	0	0	0	0	:	0	0	0	0	0	0	0	0	0	0	0	0	0	0	0	0	0	0	0	0
24	0	0	0	0	:	0	0	0	0	0	0	0	0	0	0	0	0	0	0	0	0	0	0	0	0
25	0	0	0	0	:	0	0	0	0	0	0	0	0	0	0	0	0	0	0	0	0	0	0	0	0
26	0	0	0	0	:	0	0	0	0	0	0	0	0	0	0	0	0	0	0	0	0	0	0	0	0
27	0	0	0	0	:	0	0	0	0	0	0	0	0	0	0	0	0	0	0	0	0	0	0	0	0
28	0	0	0	0	:	0	0	0	0	0	0	0	0	0	0	0	0	0	0	0	0	0	0	0	0
29	0	0	0	0	:	0	0	0	0	0	0	0	0	0	0	0	0	0	0	0	0	0	0	0	0
30	0	0	0	0	:	0	0	0	0	0	0	0	0	0	0	0	0	0	0	0	0	0	0	0	0
31	0	0	0	0	:	0	0	0	0	0	0	0	0	0	0	0	0	0	0	0	0	0	0	0	0
MEAN	0	0	0	0		0	0	0	0	0	0	0	0	0	0	0	0	0	0	0	0	0	0	0	0

TOTAL NUMBER OF OBSERVATIONS = 652 MEAN = 0.0
: INDICATES CALIBRATION FOR THE HOUR

TABLE 40. HOURLY AVERAGES OF METHANE ((UG/M**3)X10**-1) (cont.)
TRAILER NO. - 33 PERIOD(8/ 1/80 TO 8/31/80)

DAY	HOUR																								MEAN
	1	2	3	4	5	6	7	8	9	10	11	12	13	14	15	16	17	18	19	20	21	22	23	24	
1	108	106	119	130	:	108	114	129	170	160	101	99	98	97	96	93	93	92	92	93	94	98	103	101	108
2																									
3																									
4					:										91	90	90	90	90	90	90	91	90	91	90
5	91	90	91	90	:	91	91	92	92	91	91	92	93	92	91	92	91	91	92	91	93	94	93	93	92
6	92	92	92	93	:	93	100	116	117	95	94	94	93	93	92	92	94	94	94	97	102	99	104	99	97
7	118	108	104	106	:	127	130	123	135	103	94	94	94	95	94	95	97	98	100	100	103	106	109	111	106
8	109	113	146	167	:	134	132	130	157	126	113	111	115	110	103	97	97	98	98	99	98	97	107	110	116
9	108	113	115	112	:	106	107	111	108	108	98	91	91	91	90	90	90	90	91	95	91	91	91	91	99
10	94	92	92	100	:	117	111	121	114	113	109	108	108	111	113	113	113	110	112	110	109	109	112	112	109
11	107	99	100	96	:	96	95	96	101	95	94	93	93	94	94	92	91	92	92	93	96	106	98	102	96
12	93	93	92	93	:	96	95	96	98	92	92	91	91	91	91	91	91	91	92	91	91	93	95	97	93
13	98	94	95	99	:	110	114	145	144	122	95	94	92	91	91	91	91	91	90	90	91	91	91	93	100
14	92	95	96	99	:	107	103	99	102	95	92	91	92	92	92	92	92	90	91	92	92	94	95	92	95
15	91	93	93	90	:	91	91	90	91	90	91	91	91	91	90	90	91	91	90	90	90	90	91	91	91
16	91	91	91	91	:	93	93	96	96	92	91	91	91	92	92	92	92	92	91	91	91	91	91	91	92
17	92	91	91	92	:	98	101	95	92	92	91	91	91	91	91	91	91	91	92	92	91	92	92	92	92
18	94	93	92	92	:	94	99	95	94	92	92	92	92	92	92	92	91	91	91	91	91	91	91	92	92
19	93	92	92	94	:	93	97	97	95	93	92	92	92	92	91	91	91	91	91	91	91	91	92	94	93
20	94	98	97	95	:	96	101	102	102	99	95	93	92	92	92	92	91	91	91	91	93	94	101	98	95
21	94	96	100	105	:	112	108	111	127	120	97	93	93	93	93	93	93	93	93	92	95	96	95	96	99
22	104	123	124	129	:	145	133	122	124	112	102	100	103	107	111	107	105	103	104	102	102	102	103	107	112
23	124	134	137	118	:	140	162	195	208	175	143	121	114	107	105	104	105	104	102	102	102	104	110	118	128
24	123	129	138	137	:	129	127	129	137	127	128	110	109	105	118	113	107	107	106	105	106	104	104	108	118
25	109	111	136	154	:	143	175	245	220	175	133	116	120	114	107	105	102	99	98	100	111	121	121	124	132
26	111	112	104	108	:	145	157	179	204	143	113	103	98	99	99	100	101	102	101	108	101	99	104	105	117
27	99	97	97	97	:	108	141	159	171	136	106	97	97	100	100	106	101	98	97	97	101	120	104	111	110
28	102	99	104	110	:	104	130	141	113	104	96	100	101	95	96	96	98	96	95	94	95	96	96	95	103
29	94	94	103	98	:	99	104	103	93	108	147	113	103	97	95	94	93	92	93	94	95	92	92	95	100
30	97	98	97	92	:	93	94	93	94	96	94	94	93	92	93	92	92	92	91	92	91	91	92	92	93
31	91	91	91	91	:	93	93	95	96	93	93	92	92	92	92	92	92	92	92	94	94	93	94	93	93
MEAN	100	101	105	106	:	109	114	122	125	112	103	98	98	97	96	96	95	95	95	95	96	98	99	100	

TOTAL NUMBER OF OBSERVATIONS = 654 MEAN = 102.3
: INDICATES CALIBRATION FOR THE HOUR

XIV. SEPTEMBER METHANE BAG SAMPLING PROGRAM

Grab-bag samples are collected bi-weekly and analyzed for methane. The ambient air samples are collected in tedlar bags using a metal bellows pump connected to the ambient sample manifold. Each bag sample is collected over a three-hour period.

The bag samples are returned to Austin for analysis for methane concentration. The analysis is performed on either a Bendix 8202 or a Baseline Industries Model 1030 gas chromatograph using a flame ionization detector. The minimum detectable limit using this technique is less than 1 ppm.

Results of the bag sampling analyses are given below:

<u>Date</u>	<u>Time</u>	<u>Methane Concentration (ppm)</u>
9/3/80	0600-0900	2.85
9/16/80	0600-0900	5.94
9/30/80	0600-0900	2.18

TABLE 41.
DOWNTIME HOURS FOR CHOCOLATE BAYOU, TEXAS, 1980
(SEPTEMBER)

SITE 033 DIGITIZING		SO2	H2S	CH4	TSP
DATE	SYSTEM				
9/ 1	0	0	0	0	-
9/ 2	0	0	1	0	-
9/ 3	8	0	1	0	24
9/ 4	9	2	1	0	-
9/ 5	0	0	0	0	-
9/ 6	0	0	0	0	0
9/ 7	0	0	0	0	-
9/ 8	0	0	0	0	-
9/ 9	0	0	0	0	0
9/10	0	0	0	0	-
9/11	0	0	0	0	-
9/12	0	0	0	0	0
9/13	0	0	0	0	-
9/14	0	0	0	0	-
9/15	0	0	1	0	0
9/16	0	0	0	0	-
9/17	0	0	0	0	-
9/18	0	0	0	0	0
9/19	0	0	0	0	-
9/20	0	0	0	0	-
9/21	0	0	0	0	0
9/22	0	0	0	0	-
9/23	0	0	0	0	-
9/24	0	0	0	0	0
9/25	0	0	0	0	-
9/26	0	0	2	0	-
9/27	0	0	0	0	0
9/28	0	0	0	0	-
9/29	0	0	0	0	-
9/30	0	0	0	0	24
CAL TIME		34	34	32	
DATA CAPTURE RATE (%)		97	97	98	80

Downtime Summary for September 1980

During September, the data capture rate for all parameters at site 033 averaged 93 percent.

A power failure on September 3-4 resulted in approximately 17 hours of system downtime as well as the loss of the TSP sample on September 3. An air conditioner failure caused the loss of the TSP sample on September 30.

TABLE 42.

FEDERAL AND TEXAS STATE AMBIENT AIR QUALITY STANDARDS (SEPTEMBER)

Agency	Pollutant	Special Conditions		$\mu\text{g}/\text{m}^3$ Primary	(PPM)	$\mu\text{g}/\text{m}^3$ Secondary	(PPM)		
Federal and Texas	SO ₂		Annual	80	.03				
			24-Hour*	365	.14				
			3-Hour*	---		1300	.5		
Texas	SO ₂	All Counties Except	30-Minute**	1061	.4	----			
			Harris, Galveston	30-Minute**	743	.28	----		
			Orange, Jefferson	30-Minute**	849	.32	----		
Federal and Texas	Particulate		Annual***	75		60			
			24-Hour*	260		150			
Texas	Particulate		5-Hour**	100		---			
			3-Hour**	200		---			
			1-Hour**	400		---			
Federal and Texas	CO		8-Hour*	10,000	9.	10,000	9.		
			1-Hour*	40,000	35.	40,000	35.		
Federal and Texas	Ozone		1-Hour†	235	.12	235	.12		
			HC (Non-Methane)	6-9 a.m.	3-Hour*	160	.24	160	.24
			NO ₂	Annual	100	.05	100	.05	

*Not to be exceeded more than once per year.

**Texas special regulations. Single plant source may not exceed these ambient levels in Texas at any point, at any time.

***Geometric Mean.

†The expected number of exceedances not to occur on more than one calendar day per year.

TABLE 43. DAILY AVERAGES FOR SEP 1 1980 THRU SEP 30 1980

SULFUR DIOXIDE (UG/M**3)

HYDROGEN SULFIDE (UG/M**3)

METHANE ((UG/M**3)X10**-1)

SITE
DATE

033

033

033

SITE DATE	033	033	033
SEP 01	0.0	0.0	93.5
SEP 02	0.0	0.0	95.0
SEP 03	0.0	0.0	129.8
SEP 04	0.0	0.0	108.8
SEP 05	0.0	0.0	100.4
SEP 06	0.0	0.0	95.7
SEP 07	0.0	0.0	91.3
SEP 08	0.0	0.0	92.2
SEP 09	0.0	0.0	120.9
SEP 10	0.0	0.0	129.8
SEP 11	0.0	0.0	117.1
SEP 12	0.0	0.0	112.6
SEP 13	0.0	0.0	128.0
SEP 14	0.0	0.0	125.0
SEP 15	0.0	0.0	116.1
SEP 16	0.0	0.0	131.3
SEP 17	0.0	0.0	97.7
SEP 18	0.0	0.0	92.0
SEP 19	0.0	0.0	108.8
SEP 20	0.0	0.0	90.3
SEP 21	0.0	0.0	87.5
SEP 22	0.0	0.0	89.0
SEP 23	0.0	0.0	100.3
SEP 24	0.0	0.0	108.5
SEP 25	0.0	0.0	97.1
SEP 26	0.0	0.0	105.4
SEP 27	0.0	0.0	97.7
SEP 28	0.0	0.0	87.4
SEP 29	0.0	0.0	88.6
SEP 30	0.0	0.1	101.6
SEP 01 -30	0.0	0.0	104.3

TABLE 43. DAILY AVERAGES FOR SEP 1 1980 THRU SEP 30 1980 (cont.)

TOTAL SUSPENDED PARTICULATE(UG/M**3)

SITE	033
DATE	
SEP 01	
SEP 02	
SEP 03	
SEP 04	
SEP 05	
SEP 06	28.0
SEP 07	
SEP 08	
SEP 09	38.0
SEP 10	
SEP 11	
SEP 12	64.0
SEP 13	
SEP 14	
SEP 15	73.0
SEP 16	
SEP 17	
SEP 18	31.0
SEP 19	
SEP 20	
SEP 21	29.0
SEP 22	
SEP 23	
SEP 24	32.0
SEP 25	
SEP 26	
SEP 27	29.0
SEP 28	
SEP 29	
SEP 30	
SEP 01 -30	37.8

TABLE 44. THE FIVE MAXIMUM INDEPENDENT SLIDING AVERAGES FOR SEP 1, 1980 - SEP 30, 1980

SULFUR DIOXIDE (UG/M**3)
3-HOUR

SITE	033	
1.	9/ 1(0:00- 3:00)	0.0
2.	9/ 1(5:00- 8:00)	0.0
3.	9/ 1(8:00-11:00)	0.0
4.	9/ 1(11:00-14:00)	0.0
5.	9/ 1(14:00-17:00)	0.0

SULFUR DIOXIDE (UG/M**3)
24-HOUR

SITE	033	
1.	9/ 1(0:00- 0:00)	0.0
2.	9/ 2(0:00- 0:00)	0.0
3.	9/ 4(16:00-16:00)	0.0
4.	9/ 5(16:00-16:00)	0.0
5.	9/ 6(16:00-16:00)	0.0

TOTAL SUSPENDED PARTICULATE (UG/M**3)
24-HOUR

SITE	033	
1.	9/15(0:00- 0:00)	73.0
2.	9/12(0:00- 0:00)	64.0
3.	9/ 9(0:00- 0:00)	38.0
4.	9/24(0:00- 0:00)	32.0
5.	9/18(0:00- 0:00)	31.0

CORPORATION

TABLE 44. THE FIVE MAXIMUM INDEPENDENT SLIDING AVERAGES FOR SEP 1, 1980 - SEP 30, 1980
(cont.)HYDROGEN SULFIDE (UG/M**3)
1-HOUR

SITE	033	
1.	9/30(8:00- 9:00)	1.0
2.	9/30(9:00-10:00)	1.0
3.	9/ 1(2:00- 3:00)	0.0
4.	9/ 1(3:00- 4:00)	0.0
5.	9/ 1(1:00- 2:00)	0.0

METHANE ((UG/M**3) X 10**-1)
6-9 AM

SITE	033	
1.	9/16(6:00- 9:00)	323.0
2.	9/14(6:00- 9:00)	202.6
3.	9/ 3(6:00- 9:00)	180.0
4.	9/13(6:00- 9:00)	174.0
5.	9/10(6:00- 9:00)	172.6

SULFUR DIOXIDE (UG/M**3)
1-HOUR

SITE	033	
1.	9/ 1(0:00- 1:00)	0.0
2.	9/ 1(1:00- 2:00)	0.0
3.	9/ 1(2:00- 3:00)	0.0
4.	9/ 1(3:00- 4:00)	0.0
5.	9/ 1(5:00- 6:00)	0.0

TABLE 45. HOURLY AVERAGES OF SULFUR DIOXIDE (UG/M**3)
TRAILER NO. - 33 PERIOD(9/ 1/80 TO 9/30/80)

DAY	HOUR																								MEAN
	1	2	3	4	5	6	7	8	9	10	11	12	13	14	15	16	17	18	19	20	21	22	23	24	
1	0	0	0	0	:	0	0	0	0	0	0	0	0	0	0	0	0	0	0	0	0	0	0	0	0
2	0	0	0	0	:	0	0	0	0	0	0	0	0	0	0	0	0	0	0	0	0	0	0	0	0
3	0	0	0	0	:	0	0	0	0	0	0	0	0	0	0	0	0	0	0	0	0	0	0	0	0
4				0				0			0		0		0			0		0		0		0	
5	0	0	0	0	:	0	0	0	0	0	0	0	0	0	0	0	0	0	0	0	0	0	0	0	0
6	0	0	0	0	:	0	0	0	0	0	0	0	0	0	0	0	0	0	0	0	0	0	0	0	0
7	0	0	0	0	:	0	0	0	0	0	0	0	0	0	0	0	0	0	0	0	0	0	0	0	0
8	0	0	0	0	:	0	0	0	0	0	0	0	0	0	0	0	0	0	0	0	0	0	0	0	0
9	0	0	0	0	:	0	0	0	0	0	0	0	0	0	0	0	0	0	0	0	0	0	0	0	0
10	0	0	0	0	:	0	0	0	0	0	0	0	0	0	0	0	0	0	0	0	0	0	0	0	0
11	0	0	0	0	:	0	0	0	0	0	0	0	0	0	0	0	0	0	0	0	0	0	0	0	0
12	0	0	0	0	:	0	0	0	0	0:	:	0	0	0	0	0	0	0	0	0	0	0	0	0	0
13	0	0	0	0	:	0	0	0	0	0	0	0	0	0	0	0	0	0	0	0	0	0	0	0	0
14	0	0	0	0	:	0	0	0	0	0	0	0	0	0	0	0	0	0	0	0	0	0	0	0	0
15	0	0	0	0	:	0	0	0	0	0	0	0	0	0	0	0	0	0	0	0	0	0	0	0	0
16	0	0	0	0	:	0	0	0	0	0	0:	:	0:		0	0	0	0	0	0	0	0	0	0	0
17	0	0	0	0	:	0	0	0	0	0	0	0	0	0	0	0	0	0	0	0	0	0	0	0	0
18	0	0	0	0	:	0	0	0	0	0	0	0	0	0	0	0	0	0	0	0	0	0	0	0	0
19	0	0	0	0	:	0	0	0	0	0	0	0	0	0	0	0	0	0	0	0	0	0	0	0	0
20	0	0	0	0	:	0	0	0	0	0	0	0	0	0	0	0	0	0	0	0	0	0	0	0	0
21	0	0	0	0	:	0	0	0	0	0	0	0	0	0	0	0	0	0	0	0	0	0	0	0	0
22	0	0	0	0	:	0	0	0	0	0	0	0	0	0	0	0	0	0	0	0	0	0	0	0	0
23	0	0	0	0	:	0	0	0	0	0	0	0	0	0	0	0	0	0	0	0	0	0	0	0	0
24	0	0	0	0	:	0	0	0	0	0	0	0	0	0	0	0	0	0	0	0	0	0	0	0	0
25	0	0	0	0	:	0	0	0	0	0	0	0	0	0	0	0	0	0	0	0	0	0	0	0	0
26	0	0	0	0	:	0	0	0	0	0	0	0	0	0	0	0	0	0	0	0	0	0	0	0	0
27	0	0	0	0	:	0	0	0	0	0	0	0	0	0	0	0	0	0	0	0	0	0	0	0	0
28	0	0	0	0	:	0	0	0	0	0	0	0	0	0	0	0	0	0	0	0	0	0	0	0	0
29	0	0	0	0	:	0	0	0	0	0	0	0	0	0	0	0	0	0	0	0	0	0	0	0	0
30	0	0	0	0	:	0	0	0	0	0	0	0	0	0	0	0	0	0	0	0	0	0	0	0	0
MEAN	0	0	0	0		0	0	0	0	0	0	0	0	0	0	0	0	0	0	0	0	0	0	0	0

TOTAL NUMBER OF OBSERVATIONS = 670 MEAN = 0.0
: INDICATES CALIBRATION FOR THE HOUR

CORPORATION

TABLE 45. HOURLY AVERAGES OF HYDROGEN SULFIDE (UG/M**3) (cont.)
 TRAILER NO. - 33 PERIOD(9/ 1/80 TO 9/30/80)

DAY	HOUR																								MEAN
	1	2	3	4	5	6	7	8	9	10	11	12	13	14	15	16	17	18	19	20	21	22	23	24	
1	0	0	0	0	:	0	0	0	0	0	0	0	0	0	0	0	0	0	0	0	0	0	0	0	0
2	0	0	0	0	:	0	0	0	0	0	0	0	0	0	0	0	0	0	0	0	0	0	0	0	0
3	0	0	0	0	:	0	0	0	0	0	0	0	0	0	0	0	0	0	0	0	0	0	0	0	0
4				0				0		0	0	0	0	0	0				0	0	0	0	0	0	0
5	0	0	0	0	:	0	0	0	0	0	0	0	0	0	0	0	0	0	0	0	0	0	0	0	0
6	0	0	0	0	:	0	0	0	0	0	0	0	0	0	0	0	0	0	0	0	0	0	0	0	0
7	0	0	0	0	:	0	0	0	0	0	0	0	0	0	0	0	0	0	0	0	0	0	0	0	0
8	0	0	0	0	:	0	0	0	0	0	0	0	0	0	0	0	0	0	0	0	0	0	0	0	0
9	0	0	0	0	:	0	0	0	0	0	0	0	0	0	0	0	0	0	0	0	0	0	0	0	0
10	0	0	0	0	:	0	0	0	0	0	0	0	0	0	0	0	0	0	0	0	0	0	0	0	0
11	0	0	0	0	:	0	0	0	0	0	0	0	0	0	0	0	0	0	0	0	0	0	0	0	0
12	0	0	0	0	:	0	0	0	0	0	0:	:	0:	0	0	0	0	0	0	0	0	0	0	0	0
13	0	0	0	0	:	0	0	0	0	0	0	0	0	0	0	0	0	0	0	0	0	0	0	0	0
14	0	0	0	0	:	0	0	0	0	0	0	0	0	0	0	0	0	0	0	0	0	0	0	0	0
15	0	0	0	0	:	0	0	0	0	0	0	0	0	0	0	0	0	0	0	0	0	0	0	0	0
16	0	0	0	0	:	0	0	0	0	0	0	0	0:	0:	0	0	0	0	0	0	0	0	0	0	0
17	0	0	0	0	:	0	0	0	0	0	0	0	0	0	0	0	0	0	0	0	0	0	0	0	0
18	0	0	0	0	:	0	0	0	0	0	0	0	0	0	0	0	0	0	0	0	0	0	0	0	0
19	0	0	0	0	:	0	0	0	0	0	0	0	0	0	0	0	0	0	0	0	0	0	0	0	0
20	0	0	0	0	:	0	0	0	0	0	0	0	0	0	0	0	0	0	0	0	0	0	0	0	0
21	0	0	0	0	:	0	0	0	0	0	0	0	0	0	0	0	0	0	0	0	0	0	0	0	0
22	0	0	0	0	:	0	0	0	0	0	0	0	0	0	0	0	0	0	0	0	0	0	0	0	0
23	0	0	0	0	:	0	0	0	0	0	0	0	0	0	0	0	0	0	0	0	0	0	0	0	0
24	0	0	0	0	:	0	0	0	0	0	0	0	0	0	0	0	0	0	0	0	0	0	0	0	0
25	0	0	0	0	:	0	0	0	0	0	0	0	0	0	0	0	0	0	0	0	0	0	0	0	0
26	0	0	0	0	:	0	0	0	0	0	0	0	0	0	0	0	0	0	0	0	0	0	0	0	0
27	0	0	0	0	:	0	0	0	0	0	0	0	0	0	0	0	0	0	0	0	0	0	0	0	0
28	0	0	0	0	:	0	0	0	0	0	0	0	0	0	0	0	0	0	0	0	0	0	0	0	0
29	0	0	0	0	:	0	0	0	0	0	0	0	0	0	0	0	0	0	0	0	0	0	0	0	0
30	0	0	0	0	:	0	0	0	1	1	0	0	0	0	0	0	0	0	0	0	0	0	0	0	0
MEAN	0	0	0	0		0	0	0	0	0	0	0	0	0	0	0	0	0	0	0	0	0	0	0	0

TOTAL NUMBER OF OBSERVATIONS = 667

MEAN = 0.0

: INDICATES CALIBRATION FOR THE HOUR

TABLE 45. HOURLY AVERAGES OF METHANE ((UG/M**3) X 10**-1) (cont.)
TRAILER NO. - 33 PERIOD(9/ 1/80 TO 9/30/80)

DAY	HOUR																								MEAN	
	1	2	3	4	5	6	7	8	9	10	11	12	13	14	15	16	17	18	19	20	21	22	23	24		
1	93	93	94	98	:	94	94	94	93	93	93	93	93	93	92	93	93	93	93	94	93	95	93	93	93	
2	93	94	93	93	:	94	97	99	102	99	94	94	93	93	93	92	92	92	92	93	94	96	101	101	95	
3	124	116	123	127	:	187	200	182	158	135	126	105	97	90	91	86									130	
4				108	:			107		138	144	117	112	107	103			101	98	99	96	103	102	97	109	
5	96	96	107	111	:	105	121	128	117	98	95	92	91	91	91	91	95	94	98	95	96	100	102	99	100	
6	100	97	92	91	:	92	93	95	102	97	100	93	95	94	95	94	94	95	97	97	99	100	95	95	96	
7	93	92	88	88	:	89	88	88	88	88	89	89	89	89	89	91	90	92	91	93	100	99	96	101	91	
8	100	92	91	89	:	89	91	91	90	91	88	88	89	89	89	93	91	92	90	96	95	92	101	104	92	
9	94	95	96	102	:	119	164	157	166	148	151	109	103	105	108	126	106	124	104	109	115	115	129	136	121	
10	127	125	131	169	:	164	155	171	192	187	162	135	120	109	103	102	103	104	104	103	104	105	105	105	130	
11	110	128	157	150	:	146	139	138	131	134	125	117	102	98	102	106	106	106	101	98	96	97	100	106	117	
12	112	107	110	115	:	125	130	128	154	183	108	:		104	101	98	99	97	96	95	99	100	103	100	113	
13	105	119	120	121	:	124	143	174	205	199	119	125	111	107	108	106	118	107	128	142	132	106	112	114	128	
14	153	140	159	133	:	142	190	208	210	154	133	98	98	97	97	94	93	93	95	98	96	95	96	102	125	
15	103	131	128	127	:	120	115	120	136	143	113	106	103	109	106	103	104	106	106	103	108	119	133	129	116	
16	112	106	107	108	:	130	180	450	339	151	105	96	98	100	104	97	113	89	88	88	89	90	90	91	131	
17	93	93	94	97	:	95	101	116	140	113	92	92	93	92	93	97	96	93	92	94	94	92	92	93	98	
18	91	90	91	91	:	92	98	100	98	91	90	90	90	89	89	90	90	91	91	91	90	95	93	96	92	
19	97	95	97	98	:	106	110	110	125	159	132	115	104	98	99	101	103	102	105	107	103	124	112	101	109	
20	105	102	105	94	:	91	89	88	88	87	87	87	87	88	90	88	89	87	87	87	87	88	88	87	90	
21	87	87	88	88	:	88	88	90	88	87	87	87	87	87	87	87	87	87	87	87	87	88	88	88	88	
22	88	87	87	87	:	87	87	87	86	95	90	89	90	90	89	90	89	89	89	90	90	90	90	92	89	
23	93	91	89	89	:	91	115	143	125	110	89	88	88	89	91	90	89	89	112	116	105	98	107	111	100	
24	109	109	107	110	:	163	161	169	140	122	114	89	89	89	88	87	87	87	89	89	91	103	103	101	109	
25	96	92	89	90	:	96	93	101	126	110	90	89	88	92	92	90	118	99	90	92	90	90	114	107	97	
26	105	100	97	89	:	118	119	93	137	102	112	111	103	109	97	95	110	100	94	100	101	106	131	95	105	
27	92	91	92	95	:	101	91	93	98	111	118	108	112	106	108	96	91	94	90	87	92	96	92	93	98	
28	91	89	87	88	:	88	88	88	87	86	86	86	87	87	87	87	86	87	87	87	87	88	89	88	87	87
29	87	88	90	89	:	91	92	93	92	90	86	86	86	87	87	87	86	86	88	90	88	89	90	90	89	
30	90	104	104	105	:	109	115	110	108	112	108	101	98	100	100	97	95	91	95	104	103	104	94	89	102	
MEAN	101	102	104	105	:	112	119	130	132	120	108	99	96	96	96	95	97	95	96	97	97	99	101	100		

TOTAL NUMBER OF OBSERVATIONS = 672 MEAN = 104.3

: INDICATES CALIBRATION FOR THE HOUR

XV. OCTOBER METHANE BAG SAMPLING PROGRAM

Grab-bag samples are collected bi-weekly and analyzed for methane. The ambient air samples are collected in tedlar bags using a metal bellows pump connected to the ambient sample manifold. Each bag sample is collected over a three-hour period.

The bag samples are returned to Austin for analysis for methane concentration. The analysis is performed on either a Bendix 8202 or a Baseline Industries Model 1030 gas chromatograph using a flame ionization detector. The minimum detectable limit using this technique is less than 1 ppm.

Results of the bag sampling analyses are given below:

<u>Date</u>	<u>Time</u>	<u>Methane Concentration (ppm)</u>
10/4/80	0600-0900	2.68
10/31/80	0600-0900	2.05

TABLE 46.
DOWNTIME HOURS FOR CHOCOLATE BAYOU, TEXAS, 1980
(OCTOBER)

SITE 033					
DIGITIZING					
DATE	SYSTEM	SO2	H2S	CH4	TSP
10/ 1	0	0	0	0	-
10/ 2	0	0	0	0	-
10/ 3	0	0	0	0	0
10/ 4	0	0	0	0	-
10/ 5	0	0	0	0	-
10/ 6	3	0	0	0	0
10/ 7	0	0	0	0	-
10/ 8	0	0	0	0	-
10/ 9	0	0	0	0	0
10/10	0	0	3	0	-
10/11	0	0	0	0	-
10/12	0	0	0	0	0
10/13	0	0	0	0	-
10/14	0	0	0	0	-
10/15	0	0	0	0	0
10/16	0	0	0	0	-
10/17	0	0	0	0	-
10/18	0	0	0	0	0
10/19	0	0	0	0	-
10/20	0	0	0	0	-
10/21	0	0	0	0	0
10/22	0	0	0	0	-
10/23	0	0	0	0	-
10/24	0	0	1	0	0
10/25	0	0	0	0	-
10/26	0	0	0	0	-
10/27	0	0	0	0	0
10/28	0	0	0	0	-
10/29	0	0	0	0	-
10/30	0	0	0	0	0
10/31	0	0	0	0	-
CAL TIME		33	33	32	
DATA CAPTURE RATE (%)		100	99	100	100

Downtime Summary for October 1980

Data capture rates at site 033 in October were excellent, averaging 99 to 100 percent for all parameters.

A leaking methane tank on October 6 caused three hours of system downtime. Three hours of H₂S data were lost on October 10 due to repairs made on a leaking H₂S regulator.

Multipoint calibrations of all analyzers were performed on October 14. The air sampling manifold was also cleaned on the same day. The RAD-I air flow regulator and air pump were cleaned on October 20.

TABLE 47.

FEDERAL AND TEXAS STATE AMBIENT AIR QUALITY STANDARDS

Agency	Pollutant	Special Conditions		$\mu\text{g}/\text{m}^3$ Primary	(PPM)	$\mu\text{g}/\text{m}^3$ Secondary	(PPM)
Federal and Texas	SO ₂		Annual	80	.03		
			24-Hour*	365	.14		
			3-Hour*	---			1300
Texas	SO ₂	All Counties Except	30-Minute**	1061	.4	----	
		Harris, Galveston	30-Minute**	743	.28	----	
		Orange, Jefferson	30-Minute**	849	.32	----	
Federal and Texas	Particulate		Annual***	75		60	
			24-Hour*	260		150	
Texas	Particulate		5-Hour**	100		---	
			3-Hour**	200		---	
			1-Hour**	400		---	
Federal and Texas	CO		8-Hour*	10,000	9.	10,000	9.
			1-Hour*	40,000	35.	40,000	35.
Federal and Texas	Ozone		1-Hour†	235	.12	235	.12
		6-9 a.m.	3-Hour*	160	.24	160	.24
		HC (Non-Methane)	Annual	100	.05	100	.05

*Not to be exceeded more than once per year.

**Texas special regulations. Single plant source may not exceed these ambient levels in Texas at any point, at any time.

***Geometric Mean.

†The expected number of exceedances not to occur on more than one calendar day per year.

TABLE 48. DAILY AVERAGES FOR OCT 1 1980 THRU OCT 31 1980

SITE DATE	SULFUR DIOXIDE (UG/M**3)	HYDROGEN SULFIDE (UG/M**3)	METHANE((UG/M**3)X10**-1)
	033	033	033
OCT 01	0.0	0.0	91.8
OCT 02	0.0	0.0	102.3
OCT 03	0.0	0.0	103.4
OCT 04	0.0	0.0	106.6
OCT 05	0.0	0.0	107.0
OCT 06	0.0	0.0	97.9
OCT 07	0.0	0.0	134.3
OCT 08	0.0	0.0	105.8
OCT 09	0.0	0.0	100.3
OCT 10	0.0	0.3	143.7
OCT 11	0.0	0.0	98.0
OCT 12	1.0	0.0	103.7
OCT 13	0.0	0.0	116.7
OCT 14	0.0	0.0	92.0
OCT 15	0.0	0.0	77.0
OCT 16	0.0	0.0	74.8
OCT 17	0.0	0.0	71.7
OCT 18	0.0	0.0	75.4
OCT 19	0.0	0.0	90.9
OCT 20	0.0	0.0	94.1
OCT 21	1.3	0.0	107.0
OCT 22	0.4	0.0	108.5
OCT 23	2.0	0.0	138.2
OCT 24	0.0	0.0	93.5
OCT 25	0.0	0.0	116.8
OCT 26	0.0	0.0	106.5
OCT 27	0.0	0.0	74.4
OCT 28	0.0	0.0	90.9
OCT 29	0.0	0.0	87.5
OCT 30	0.7	0.0	106.2
OCT 31	0.6	0.0	139.6
OCT 01 -31	0.2	0.0	101.8

TABLE 48. DAILY AVERAGES FOR OCT 1 1980 THRU OCT 31 1980 (cont.)

176

TOTAL SUSPENDED PARTICULATE(UG/M**3)

SITE DATE	033
OCT 01	
OCT 02	
OCT 03	68.0
OCT 04	
OCT 05	
OCT 06	47.0
OCT 07	
OCT 08	
OCT 09	46.0
OCT 10	
OCT 11	
OCT 12	77.0
OCT 13	
OCT 14	
OCT 15	34.0
OCT 16	
OCT 17	
OCT 18	43.0
OCT 19	
OCT 20	
OCT 21	64.0
OCT 22	
OCT 23	
OCT 24	45.0
OCT 25	
OCT 26	
OCT 27	42.0
OCT 28	
OCT 29	
OCT 30	59.0
OCT 31	
OCT 01 -31	51.0

TABLE 49. THE FIVE MAXIMUM INDEPENDENT SLIDING AVERAGES FOR OCT 1, 1980 - OCT 31, 1980

SULFUR DIOXIDE (UG/M**3)
3-HOUR

SITE	033
1.10/23(8:00-11:00)	15.6
2.10/21(11:00-14:00)	9.6
3.10/12(9:00-12:00)	8.0
4.10/30(11:00-14:00)	5.3
5.10/31(7:00-10:00)	4.3

SULFUR DIOXIDE (UG/M**3)
24-HOUR

SITE	033
1.10/22(11:00-11:00)	2.3
2.10/20(14:00-14:00)	1.1
3.10/30(10:00-10:00)	1.1
4.10/11(19:00-19:00)	1.0
5.10/ 7(0:00- 0:00)	0.0

TOTAL SUSPENDED PARTICULATE (UG/M**3)
24-HOUR

SITE	033
1.10/12(0:00- 0:00)	77.0
2.10/ 3(0:00- 0:00)	68.0
3.10/21(0:00- 0:00)	64.0
4.10/30(0:00- 0:00)	59.0
5.10/ 6(0:00- 0:00)	47.0

TABLE 49. THE FIVE MAXIMUM INDEPENDENT SLIDING AVERAGES FOR OCT 1, 1980 - OCT 31, 1980
(cont.)

178

HYDROGEN SULFIDE (UG/M**3)
1-HOUR

SITE	033
1.10/10(5:00- 6:00)	4.0
2.10/ 2(8:00- 9:00)	1.0
3.10/10(10:00-11:00)	1.0
4.10/ 1(3:00- 4:00)	0.0
5.10/ 1(2:00- 3:00)	0.0

METHANE ((UG/M**3)X10**-1)
6-9 AM

SITE	033
1.10/23(6:00- 9:00)	303.3
2.10/10(6:00- 9:00)	272.0
3.10/31(6:00- 9:00)	256.3
4.10/ 7(6:00- 9:00)	239.6
5.10/13(6:00- 9:00)	187.6

SULFUR DIOXIDE (UG/M**3)
1-HOUR

SITE	033
1.10/21(13:00-14:00)	29.0
2.10/23(8:00- 9:00)	26.0
3.10/12(11:00-12:00)	21.0
4.10/23(9:00-10:00)	18.0
5.10/22(15:00-16:00)	10.0

TABLE 50. HOURLY AVERAGES OF SULFUR DIOXIDE (UG/M**3)
TRAILER NO. - 33 PERIOD(10/ 1/80 TO 10/31/80)

DAY	HOUR																								MEAN	
	1	2	3	4	5	6	7	8	9	10	11	12	13	14	15	16	17	18	19	20	21	22	23	24		
1	0	0	0	0	:	0	0	0	0	0	0	0	0	0	0	0	0	0	0	0	0	0	0	0	0	
2	0	0	0	0	:	0	0	0	0	0	0	0	0	0	0	0	0	0	0	0	0	0	0	0	0	
3	0	0	0	0	:	0	0	0	0	0	0	0	0	0	0	0	0	0	0	0	0	0	0	0	0	
4	0	0	0	0	:	0	0	0	0	0	0	0	0	0	0	0	0	0	0	0	0	0	0	0	0	
5	0	0	0	0	:	0	0	0	0	0	0	0	0	0	0	0	0	0	0	0	0	0	0	0	0	
6	0	0	0	0	:	0	0	0	0	0	0	0	0	0	0	0	0	0	0	0	0	0	0	0	0	
7	0	0	0	0	:	0	0	0	0	0	0	0	0	0	0	0	0	0	0	0	0	0	0	0	0	
8	0	0	0	0	:	0	0	0	0	0	0	0	0	0	0	0	0	0	0	0	0	0	0	0	0	
9	0	0	0	0	:	0	0	0	0	0	0	0	0	0	0	0	0	0	0	0	0	0	0	0	0	
10	0	0	0	0	:	0	0	0	0	0	0	0	0	0	0	0	0	0	0	0	0	0	0	0	0	
11	0	0	0	0	:	0	0	0	0	0	0	0	0	0	0	0	0	0	0	0	0	0	0	0	0	
12	0	0	0	0	:	0	0	0	0	0	0	3	21	0	0	0	0	0	0	0	0	0	0	0	0	1
13	0	0	0	0	:	0	0	0	0	0	0	0	0	0	0	0	0	0	0	0	0	0	0	0	0	
14	0	0	0	0	:	0	0	0	0	0	0	0	0	0	0	0	0	0	0	0	0	0	0	0	0	
15	0	0	0	0	:	0	0	0	0	0	0	0	0	0	0	0	0	0	0	0	0	0	0	0	0	
16	0	0	0	0	:	0	0	0	0	0	0	0	0	0	0	0	0	0	0	0	0	0	0	0	0	
17	0	0	0	0	:	0	0	0	0	0	0	0	0	0	0	0	0	0	0	0	0	0	0	0	0	
18	0	0	0	0	:	0	0	0	0	0	0	0	0	0	0	0	0	0	0	0	0	0	0	0	0	
19	0	0	0	0	:	0	0	0	0	0	0	0	0	0	0	0	0	0	0	0	0	0	0	0	0	
20	0	0	0	0	:	0	0	0	0	0	0	0	0	0	0	0	0	0	0	0	0	0	0	0	0	
21	0	0	0	0	:	0	0	0	0	0	0	0	0	0	29	0	0	0	0	0	0	0	0	0	0	1
22	0	0	0	0	:	0	0	0	0	0	0	0	0	0	0	10	0	0	0	0	0	0	0	0	0	0
23	0	0	0	0	:	0	0	0	26	18	3	0	0	0	0	0	0	0	0	0	0	0	0	0	0	2
24	0	0	0	0	:	0	0	0	0	0	0	0	0	0	0	0	0	0	0	0	0	0	0	0	0	0
25	0	0	0	0	:	0	0	0	0	0	0	0	0	0	0	0	0	0	0	0	0	0	0	0	0	0
26	0	0	0	:	0	0	0	0	0	0	0	0	0	0	0	0	0	0	0	0	0	0	0	0	0	0
27	0	0	0	:	0	0	0	0	0	0	0	0	0	0	0	0	0	0	0	0	0	0	0	0	0	0
28	0	0	0	0	:	0	0	0	0	0	0	0	0	0	0	0	0	0	0	0	0	0	0	0	0	0
29	0	0	0	0	:	0	0	0	0	0	0	0	0	0	0	0	0	0	0	0	0	0	0	0	0	0
30	0	0	0	0	:	0	0	0	0	0	0	0	0	8	8	0	0	0	0	0	0	0	0	0	0	0
31	0	0	0	0	:	0	0	0	5	8	0	0	0	0	0	0	0	0	0	0	0	0	0	0	0	1
MEAN	0	0	0	0	0	0	0	0	1	1	0	1	0	1	0	0	0	0	0	0	0	0	0	0	0	0

TOTAL NUMBER OF OBSERVATIONS = 709 MEAN = 0.2
: INDICATES CALIBRATION FOR THE HOUR

TABLE 50. HOURLY AVERAGES OF HYDROGEN SULFIDE (UG/M**3) (cont.)
TRAILER NO. - 33 PERIOD(10/ 1/80 TO 10/31/80)

081

DAY	HOUR																								MEAN
	1	2	3	4	5	6	7	8	9	10	11	12	13	14	15	16	17	18	19	20	21	22	23	24	
1	0	0	0	0	:	0	0	0	0	0	0	0	0	0	0	0	0	0	0	0	0	0	0	0	0
2	0	0	0	0	:	0	0	0	1	0	0	0	0	0	0	0	0	0	0	0	0	0	0	0	0
3	0	0	0	0	:	0	0	0	0	0	0	0	0	0	0	0	0	0	0	0	0	0	0	0	0
4	0	0	0	0	:	0	0	0	0	0	0	0	0	0	0	0	0	0	0	0	0	0	0	0	0
5	0	0	0	0	:	0	0	0	0	0	0	0	0	0	0	0	0	0	0	0	0	0	0	0	0
6	0	0	0	0	:	0	0	0	0	0	0	0	0	0	0	0	0	0	0	0	0	0	0	0	0
7	0	0	0	0	:	0	0	0	0	0	0	0	0	0	0	0	0	0	0	0	0	0	0	0	0
8	0	0	0	0	:	0	0	0	0	0	0	0	0	0	0	0	0	0	0	0	0	0	0	0	0
9	0	0	0	0	:	0	0	0	0	0	0	0	0	0	0	0	0	0	0	0	0	0	0	0	0
10	0	0	0	0	:	4	0				1	0	0	0	0	0	0	0	0	0	0	0	0	0	0
11	0	0	0	0	:	0	0	0	0	0	0	0	0	0	0	0	0	0	0	0	0	0	0	0	0
12	0	0	0	0	:	0	0	0	0	0	0	0	0	0	0	0	0	0	0	0	0	0	0	0	0
13	0	0	0	0	:	0	0	0	0	0	0	0	0	0	0	0	0	0	0	0	0	0	0	0	0
14	0	0	0	0	:	0	0	0	0	0	0:	:	0	0	0	0	0	0	0	0	0	0	0	0	0
15	0	0	0	0	:	0	0	0	0	0	0	0	0	0	0	0	0	0	0	0	0	0	0	0	0
16	0	0	0	0	:	0	0	0	0	0	0	0	0	0	0	0	0	0	0	0	0	0	0	0	0
17	0	0	0	0	:	0	0	0	0	0	0	0	0	0	0	0	0	0	0	0	0	0	0	0	0
18	0	0	0	0	:	0	0	0	0	0	0	0	0	0	0	0	0	0	0	0	0	0	0	0	0
19	0	0	0	0	:	0	0	0	0	0	0	0	0	0	0	0	0	0	0	0	0	0	0	0	0
20	0	0	0	0	:	0	0	0	0	0	0	0	0	0	0	0	0	0	0	0	0	0	0	0	0
21	0	0	0	0	:	0	0	0	0	0	0	0	0	0	0	0	0	0	0	0	0	0	0	0	0
22	0	0	0	0	:	0	0	0	0	0	0	0	0	0	0	0	0	0	0	0	0	0	0	0	0
23	0	0	0	0	:	0	0	0	0	0	0	0	0	0	0	0	0	0	0	0	0	0	0	0	0
24	0	0	0	0	:	0	0	0	0	0	0	0	0	0	0	0	0	0	0	0	0	0	0	0	0
25	0	0	0	0	:	0	0	0	0	0	0	0	0	0	0	0	0	0	0	0	0	0	0	0	0
26	0	0	0	:	0	0	0	0	0	0	0	0	0	0	0	0	0	0	0	0	0	0	0	0	0
27	0	0	0	:	0	0	0	0	0	0	0	0	0	0	0	0	0	0	0	0	0	0	0	0	0
28	0	0	0	0	:	0	0	0	0	0	0	0	0	0	0	0	0	0	0	0	0	0	0	0	0
29	0	0	0	0	:	0	0	0	0	0	0	0	0	0	0	0	0	0	0	0	0	0	0	0	0
30	0	0	0	0	:	0	0	0	0	0	0	0	0	0	0	0	0	0	0	0	0	0	0	0	0
31	0	0	0	0	:	0	0	0	0	0	0	0	0	0	0	0	0	0	0	0	0	0	0	0	0
MEAN	0	0	0	0	0	0	0	0	0	0	0	0	0	0	0	0	0	0	0	0	0	0	0	0	0

TOTAL NUMBER OF OBSERVATIONS = 705 MEAN = 0.0
: INDICATES CALIBRATION FOR THE HOUR

TABLE 50. HOURLY AVERAGES OF METHANE((UG/M**3) X 10**-1) (cont.)
TRAILER NO. - 33 PERIOD(10/ 1/80 TO 10/31/80)

DAY	HOUR																								MEAN	
	1	2	3	4	5	6	7	8	9	10	11	12	13	14	15	16	17	18	19	20	21	22	23	24		
1	95	91	89	102	94:	85	87	96	102	107	114	93	86	86	84	83	81	84	86	87	90	91	92	98	92	
2	97	95	93	97	116:	141	156	142	129	102	95	87	89	85	85	88	91	91	92	95	95	96	105	93	102	
3	92	95	96	94	111:	113	148	182	160	136	115	92	85	82	80	79	80	81	82	83	102	96	97	101	103	
4	109	116	110	107	117:	115	167	182	143	120	110	98	99	93	92	89	87	85	89	89	85	86	86	84	107	
5	86	90	114	112	119:	124	157	152	189	136	111	102	95	90	85	84	84	84	85	89	90	96	91	103	107	
6	98	102	98	111	122:	117	102	99	106	105	102	95	91				85	83	89	86	85	89	90	101	98	
7	151	168	151	135	199:	248	266	246	207	141	115	95	92	90	91	87	91	93	92	105	92	88	89	92	134	
8	103	113	107	122	112:	117	134	148	143	139	118	90	91	88	92	94	93	93	92	89	93	90	89	88	106	
9	91	95	108	114	117:	108	97	93	100	131	107	85	82	83	81	79	81	85	94	107	100	140	120	108	100	
10	105	97	102	121	154:	144	179	351	286	284	196	106	95	92	93	109	115	152	210	99	85	90	91	93	144	
11	100	104	112	109	94:	110	115	117	115	109	97	89	85	87	84	83	82	82	81	85	89	94	117	111	98	
12	128	132	121	112	107:	104	116	120	133	111	95	92	89	88	83	83	88	87	90	88	88	131	103	99	104	
13	120	125	113	105	145:	196	215	168	180	180	137	82	82	81	81	82	82	83	84	86	86	87	94	106	117	
14	95	99	90	83	84:	95	115	157	155	94	82	81		:	82	81	81	80	81	81	84	83	80	77	92	
15	76	76	77	76	76:	76	76	77	77	76	76	76	76	76	76	76	77	78	78	80	84	82	75	74	77	
16	75	75	74	75	75:	78	76	75	75	75	76	76	76	77	76	75	75	74	73	73	74	73	73	73	75	
17	72	72	72	72	72:	72	71	71	72	71	71	71	71	71	71	71	72	72	71	71	72	73	72	73	73	72
18	76	79	79	76	73:	73	74	75	75	72	72	71	71	71	71	71	71	78	81	80	80	81	80	79	75	
19	84	87	85	90	111:	101	94	85	87	94	92	94	92	86	84	83	83	84	80	87	97	91	107	104	91	
20	102	96	98	90	92:	91	101	123	138	114	93	88	85	84	83	88	84	86	87	86	86	87	89	88	94	
21	88	87	89	90	95:	98	103	128	145	167	168	162	115	102	96	94	90	90	89	91	90	95	99	98	107	
22	92	90	94	122	160:	159	149	149	142	146	110	97	85	85	86	88	88	92	94	91	88	93	95	110	109	
23	135	128	128	131	157:	174	256	330	324	216	132	107	96	92	88	91	95	91	89	88	91	90	93	95	138	
24	95	93	95	110	109:	117	127	94	87	87	85	83	82	82	82	82	83	81	83	86	92	102	98	109	94	
25	153	149	120	111	148:	181	164	179	165	139	98	88	87	88	89	89	89	96	93	107	102	86	90	91	117	
26	108	132	141	163:	183	178	195	186	93	82	81	80	79	79	79	79	78	78	78	78	77	77	76	75	106	
27	75	76	75	74:	75	75	75	76	76	76	76	74	73	73	74	72	72	72	73	73	73	74	76	77	74	
28	87	93	91	105	95:	92	93	91	89	89	86	91	93	89	91	92	88	85	85	91	90	92	94	89	91	
29	87	85	84	87	85:	85	85	86	86	87	89	93	88	86	87	86	85	85	86	90	96	91	90	91	88	
30	102	102	103	114	147:	126	127	129	140	110	91	88	92	90	88	87	87	90	98	90	116	127	99	106	106	
31	108	112	124	165	293:	289	268	277	224	125	106	95	86	88	95	94	91	95	95	94	95	100	111	120	140	
MEAN	100	102	101	106	121	125	135	145	137	120	103	91	87	85	84	85	85	87	90	88	89	92	92	94		

TOTAL NUMBER OF OBSERVATIONS = 740 MEAN = 101.8
: INDICATES CALIBRATION FOR THE HOUR

Appendix II: Microseismic Monitoring

MICROSEISMICITY AT THE BRAZORIA COUNTY
GEOPRESSURED RESERVOIR
ANNUAL REPORT 1980

1. INTRODUCTION

1.1 BACKGROUND AND PURPOSE OF THE MONITORING PROGRAM

The commercial feasibility of producing the vast quantities of geopressured brine underlying the Gulf Coast is dependent upon high volumetric production rates. The production requirements for effective withdrawal and subsurface disposal of geopressured fluids is generally near 3×10^4 /barrels/day/well. Volumes of this order, by substantially altering the local state of subsurface stress, will likely cause ground subsidence and tilt in the immediate area of brine withdrawal. Rejection of these fluids may activate preexisting growth faults as well as cause new fracturing to occur.

To investigate the seismic risks associated with geopressured fluid production, Teledyne Geotech, with the authorization by the Texas Bureau of Economic Geology, has conducted a seismic monitoring program for the past twenty-eight months in the vicinity of the Brazoria County geopressured well test site. According to prescheduled test plans, the Brazoria County Pleasant Bayou No. 2 is to be produced in a long-term flow test from depths near 15,000 feet (4572 m) at rates approaching 30,000 BPD ($3577 \text{ m}^3/\text{day}$). The brines will be reinjected at a depth of approximately 6500 feet (1981 m) into the Pleasant Bayou No. 1 well test, located approximately 500 meters from the production well.

The monitoring program was designed first to establish the nature of the local seismic activity prior to production and second to provide continued surveillance of the area during the well test.

By comparing the data sets compiled prior to and following initiation of well production, we expect to detect any increase in microseismicity that might be associated with either the reinjection process or with actual changes in the (production well) reservoir geometry. In addition, numerous growth faults exist in the immediate vicinity of the test well, and analysis of the microseismic data will reveal any abrupt failure resulting from activation of these preexisting fault planes.

2. DATA COLLECTION AND ANALYSIS

2.1 FIELD MEASUREMENTS

The monitoring network instrumentation consists of five borehole seismometers (Geotech Model S-500) installed in sealed containers at a depth of approximately 100 feet. Signals from the seismometers are conditioned by low-noise amplifier/filters, Geotech Model 42.50. The amplitude data are then transformed to constant-bandwidth, frequency-modulated format using the Geotech Model 46.22 voltage controlled oscillator (VCO). The locations of the seismograph stations and the configuration of the Brazoria array, as well as the test well, are illustrated on figure 1. The geographical coordinates and the X (east-west) and Y (north-south) coordinates of the individual sensor sites with respect to station 3 are listed in table 1.

Table 1. Site coordinates.

Site	Latitude			Longitude			N-S (km)	E-W (km)	Elevation (feet)
	Deg	Min	Secs	Deg	Min	Secs			
1	29	17	27	95	16	52	1.027	-2.422	-87
2	29	17	32	95	14	01	1.171	2.242	-87
3	29	16	54	95	15	23	0.000	0.000	-97
4	29	15	54	95	14	45	-1.872	1.032	-90
5	29	15	54	95	16	11	-1.898	-1.284	-84

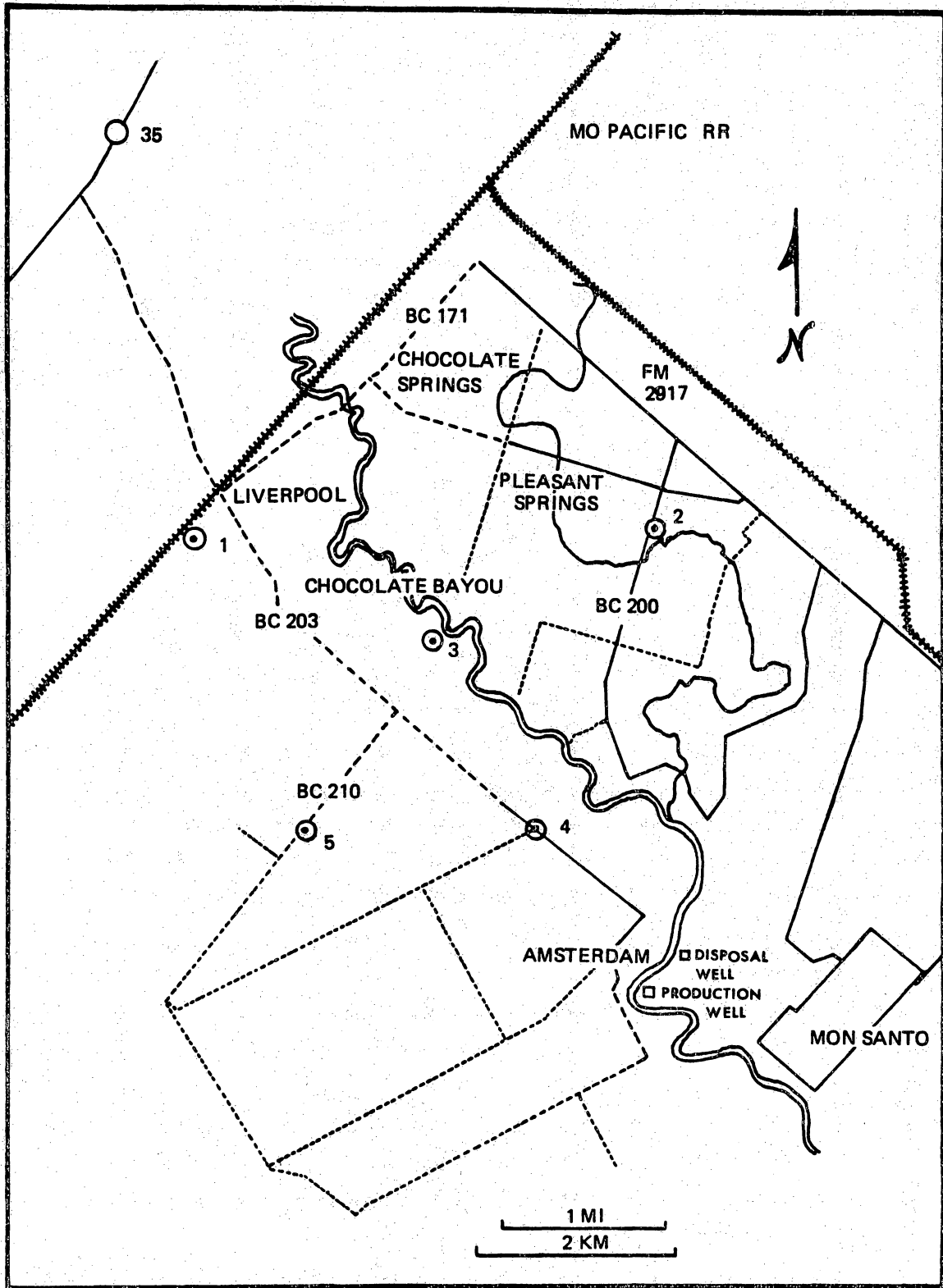

Figure 1. Location of sensor sites of Brazoria County field program.

Figure 2 illustrates a block diagram of the data acquisition system. Data from four of the sites are transmitted via local telephone circuits to a collection point in Liverpool, Texas. At that location, the signals are multiplexed together with the signal from a nearby sensor (site 1 in figure 1) and then are transmitted via commercial telephone line to the Teledyne Geotech laboratory at Garland. In the laboratory, the signals are demultiplexed and the individual channels are recorded both on magnetic tape and 16 mm film. The unity gain velocity response of the overall system (from film) is shown in figure 3.

2.2 DATA ANALYSIS PROCEDURES

The film records are reviewed to tabulate microseismic activity, to assess the general quality of the data, and to obtain information on detection thresholds. The measurement of apparent velocity of signals across the array permits an initial separation of source types as illustrated in figure 4. Only events having apparent velocities exceeding 1000 m/sec are considered important at this time. The events of interest can be further separated based on frequency content and duration of the signals. Only the events which are classified as local on figure 4 are processed further. The arrival time data of local events are processed by MEHYPO (Johnson et al., 1977), a computer program which determines the hypocenter, the magnitude and estimations of parameter accuracy of the local events. The location program utilizes both compressional (P-wave) and shear (S-wave) arrivals, tracing the refracted paths through an appropriate earth model. The solution is based upon conventional least squares minimization criteria. Many acoustic velocity signals also have been processed assuming a single layer with a velocity of .33 km/sec.

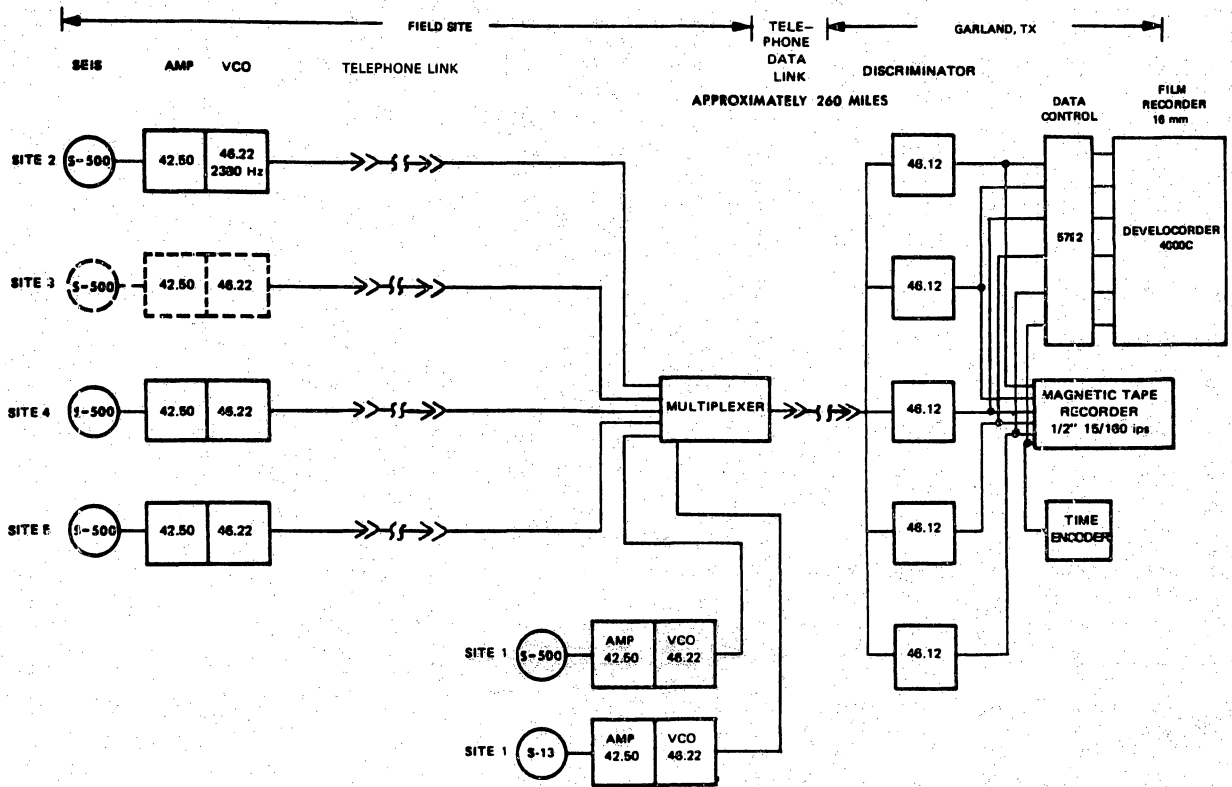
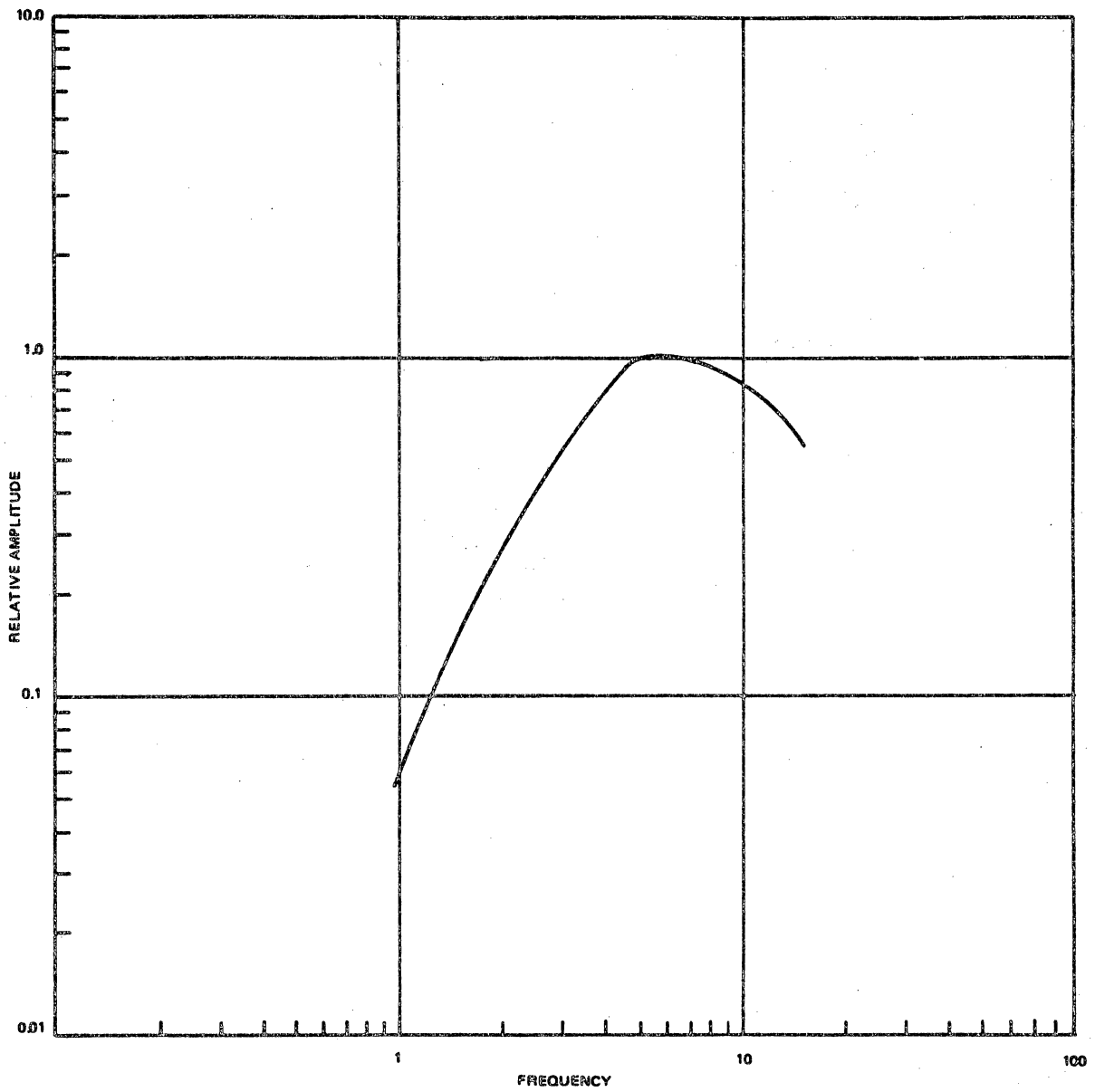

Figure 2. Block diagram of the Brazoria County monitoring system.



FILTERS AT 5.0 Hz LO CUT, 50 Hz HI CUT

Figure 3. Velocity response of the monitoring systems (from film).

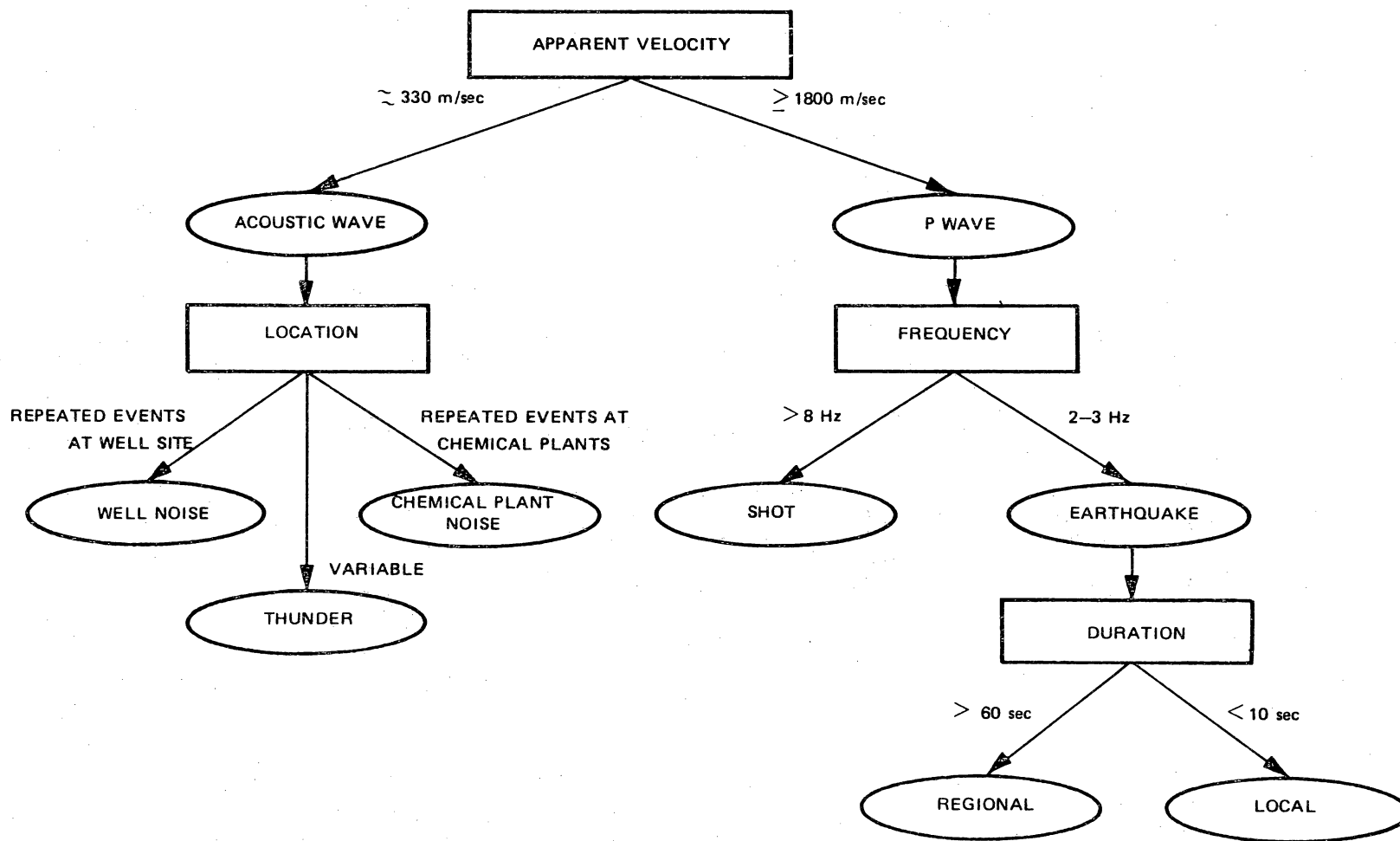

Figure 4. Tentative classification of events by source type.

Hypocenters are computed only for events observed at three or more stations. Local seismic magnitudes are based upon maximum amplitude and are calculated as:

$$M_L = \log_{10} (A/2) - 1.75 + 0.8 \log_{10} (X^2)$$

where: M_L is the local magnitude

A is the peak-to-peak compressional wave amplitude in nanometers (10^{-9} meters)

$$X = [(\text{epicentral distance})^2 + (\text{hypocentral depth})^2]^{1/2}$$

(in kilometers) (in kilometers)

and X must be ≥ 1.0

3. OBSERVED ACTIVITY

3.1 SIGNALS FAILING CRITERIA TO BE IDENTIFIED AS MICROEARTHQUAKES

During 1981, further effort was directed to determining the sources of the acoustic velocity signals which appeared to originate near known growth faults. Although these events tend to concentrate in two regions south of Site 1 and east of Site 5, the low velocity of these signals is not consistent with conventional microseismicity because high velocity body waves are not observed. A few records showed evidence of local electrical interference prior to the time of the acoustic signal across the array suggesting that thunder may be the source of these events. Figure 5 is a histogram showing the number of these events which occurred each day from October 1979 to August 1980. Arrows indicate days on which thunder was reported at the Houston Intercontinental Airport. Considering that the array is approximately 100 km from the airport, the correlation illustrated in figure 5 is quite remarkable. The spatial distribution of these events can be explained by the presence of a line of high metal towers supporting power lines. Shown as a dashed line in figure 6, it terminates at one concentration of activity and passes through the other. Additional locations

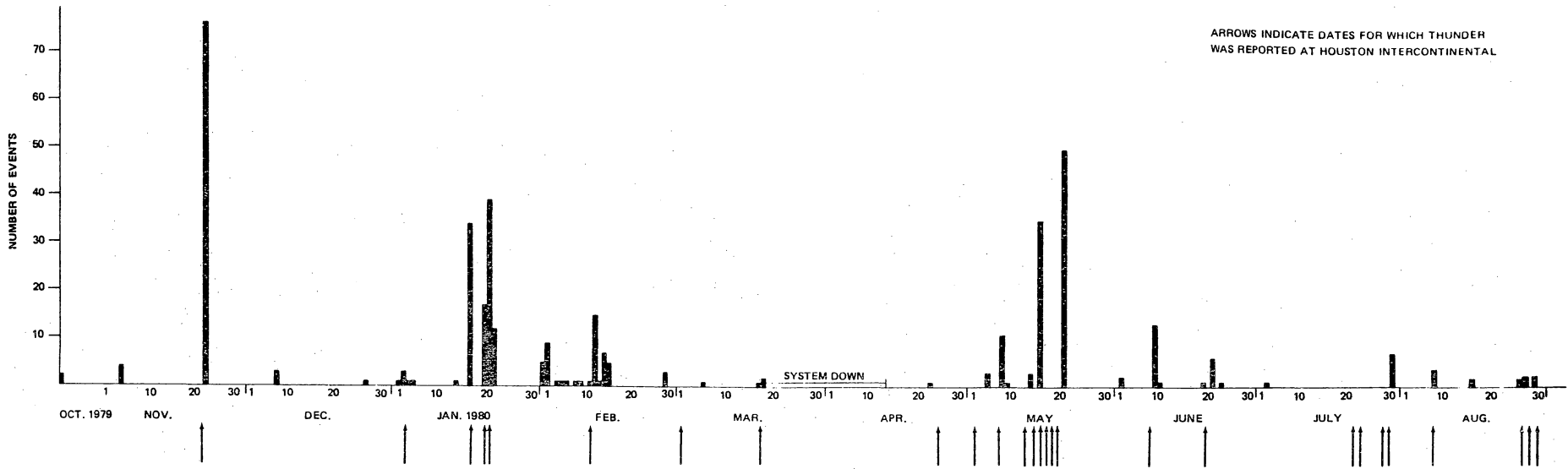

Figure 5. Brazoria County seismicity and local thunder activity.

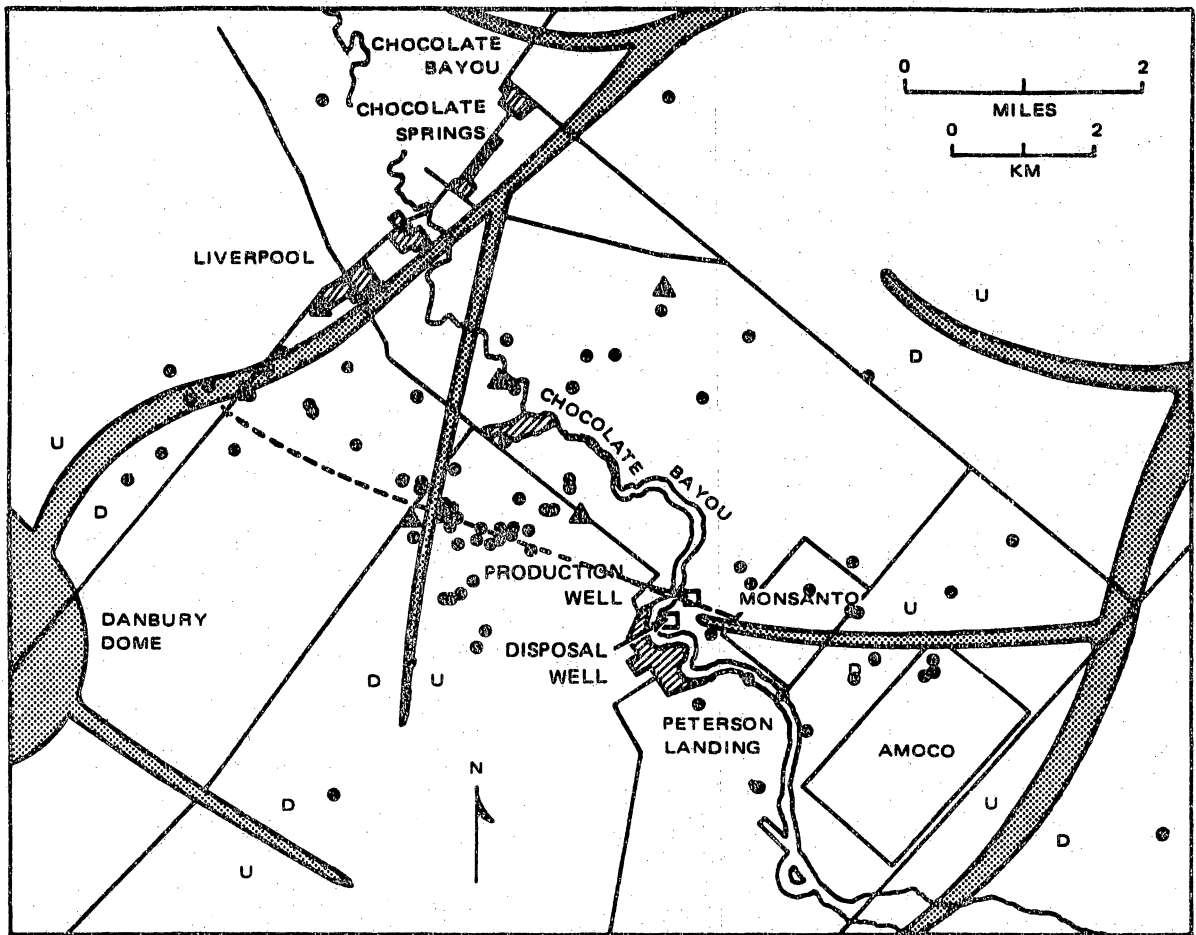

Figure 6. Cumulative epicenter map for natural events as of May 30, 1980.

- ▲ STATIONS
- NATURAL EVENTS
- HIGH TENSION POWER LINE

scattered about the petrochemical plants may be due to lightning strikes near the plants.

Acoustic velocity signals also frequently emanate from a narrow region passing through the petrochemical plants. These are similar to the thunder signals described above except that they commonly occur in sequences of tens to hundreds of nearly identical signals with nearly identical source locations. These events are poorly understood but clearly are related to some activity at the chemical facility.

Seismic exploration shots also are observed during daylight hours and have distinctive high frequency, high velocity characteristics. Located events generally lie in straight lines parallel to perpendicular to the regional structure.

3.2 SIGNALS OBSERVED WHICH COULD BE IDENTIFIED AS MICROEARTHQUAKES

On 30 November at about 01:49 CST, two small events were detected which had coherent arrivals within 0.8 second at all five sites. The computed epicentral (surface projection) locations of these events are illustrated as open circles on figure 7. Hypocentral depths were calculated as 5.9 and 2.6 km and magnitudes as 1.08 and 0.52. The source parameters of these two events have large uncertainties, however.

A microearthquake having a magnitude of 1.6 occurred on 1 January 1981 at 03:32:29.293 UCT (Universal Coordinated Time) (31 December 1980, 21:32:29.293 CST). The epicenter of this event is shown on figure 7 as a solid circle. The 95% confidence error ellipse axes are indicated as bar extensions from the epicenter circle. The semimajor axes lengths are 602 m and 431 m, respectively, and the error ellipse encloses a region of 0.816 km². The hypocentral depth is computed to be 5.4 km. Considering the quality of the seismograms, this is a remarkably well constrained event.

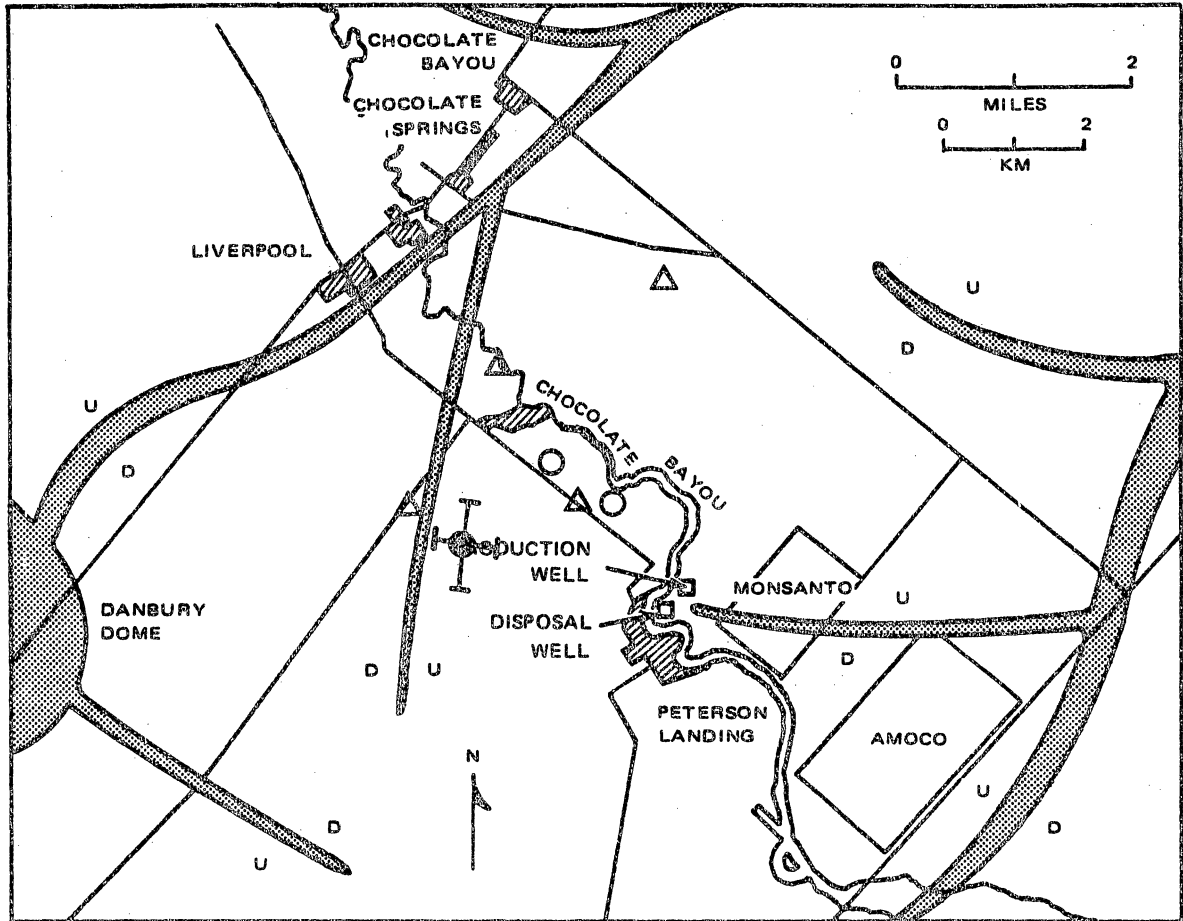

Figure 7. Epicenter map for possible microearthquake events. Growth faults are mapped at 15,000-ft depth.

- NOV 30, 1980
- DEC 31, 1980

The seismograms for this earthquake are given in figure 8. The approximate arrival time of the direct P-wave, S-wave, and Rayleigh wave are indicated on the figure. Unfortunately, the phase arrivals of the P-wave are emergent at the stations so that unambiguous first motion directions could not be determined. The duration of the earthquake from the onset of P through the surface wave coda is approximately 25 seconds, and the sustained velocity amplitude of the surface waves is 1400 nanometers on the average. Both are expected characteristics of earthquakes of this magnitude. The dominant frequency of the surface wave is approximately 2.0 Hertz \pm 0.5 Hertz.

The frequency content of both the P-wave and S-wave are quite surprising for a magnitude 1.6 earthquake, however. Generally, an event of this magnitude recorded in other locations such as the continental interior would have a P-wave frequency content in excess of 5 Hertz. This earthquake, on the other hand, had a P-wave and S-wave with dominant periods near one second. Considering the requisite small source dimensions dictated by the magnitude, it is most likely that the long-period P-wave pulse is a manifestation of a slow rupturing process. The proximity of the computed hypocenter to a known growth fault strongly suggests that the recorded earthquake was generated by movement along that fault. If this earthquake is characteristic of the induced local seismicity, then the passband of the instrumentation needs to be broadened to record the initial body waves with a higher signal-to-noise ratio.

DISCUSSION

The low level of seismicity observed to date does not preclude a seismicity associated with the production of the geopressured brines at the Brazoria well. In fact, there may be a considerable time lag between the times of production

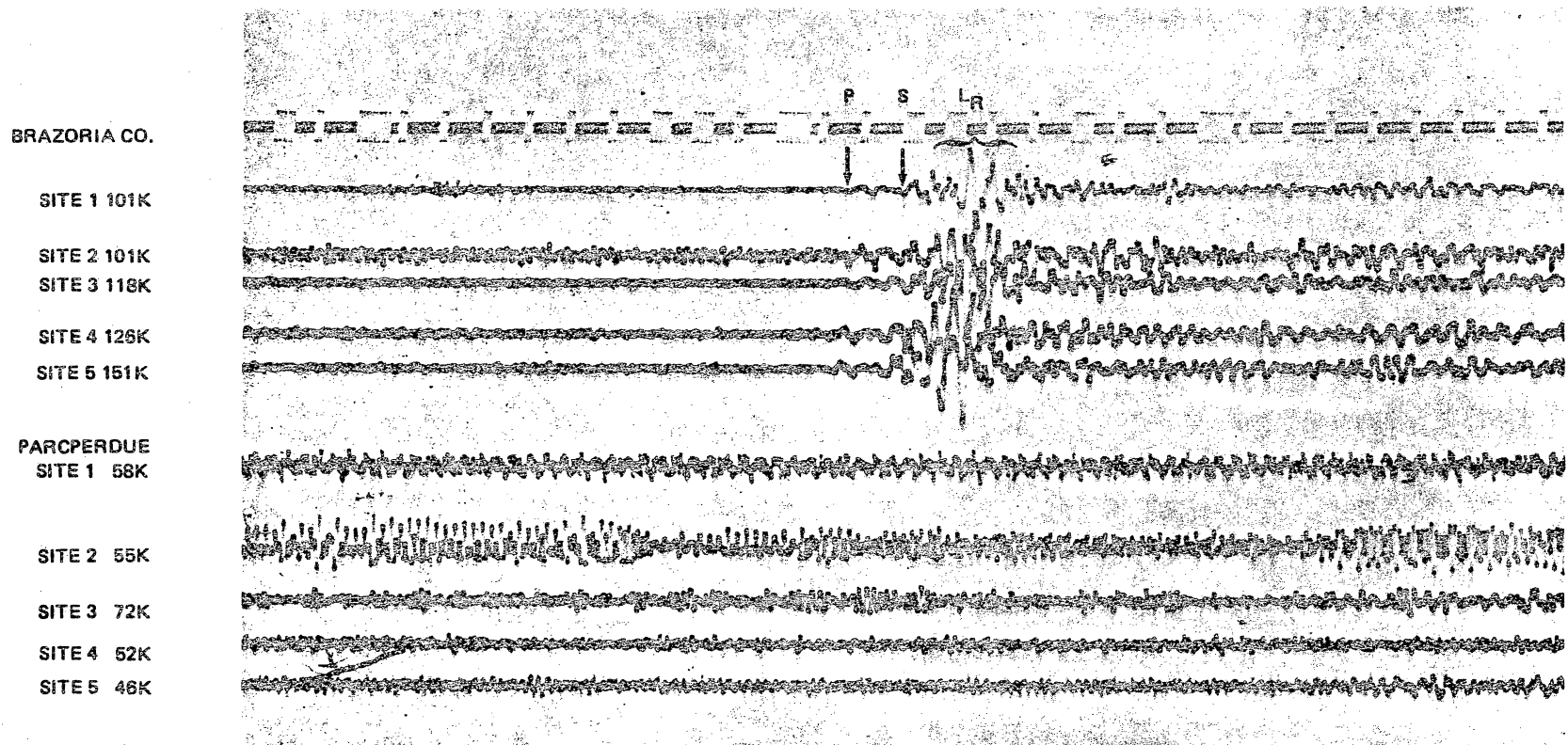

Figure 8. Background noise samples with microseismic event (magnitude 1.6),
1 January 1981 03:32:29.29 UCT (31 December 1980 21:32:29.29 CST).

and associated subsidence. This lag time for the appearance of subsidence effects at the surface following high level production from deep reservoirs has been documented previously for the Chocolate Bayou area (Grimsrud, Turner and Frame, 1978). Although the lag time between brine production and induced seismic activity at depth is not expected to be as long as the lag for the appearance of surficial effects, it could be tens to hundreds of days following cessation of pumping before strain relaxation of the rock occurs. This could explain why detectable seismic events have occurred 30 to 60 days following the ending of the last test. With only two events thus far recorded, however, it is not reasonable to carry speculation too far.

The appearance of two clearly identifiable microearthquakes, one of which is relatively well constrained, located near a growth fault and is at a depth similar to that of the brine production, does indicate some strain relaxation has occurred at the production level. It remains to be seen whether or not the rate of seismic activity along the growth fault with time.

Constraining the depth of subsequent events may be critical to understanding the relaxation process. In addition, spectral analyses of better recorded subsequent events may help to understand the time history of rupturing which creates such long-period P-wave pulses from such small events.

4. RESULTS

January

Table 2 summarizes microseismicity at the array during January. There were 343 shot signals and 109 surface wave signals. Seismic surveying has continued across regions A, B and C and has occurred for the first time in regions G, H and I. Apparently the fourth side of a 2 mile square is being completed.

Table 2. January 1980 microseismicity by region.

<u>Region</u>	<u>Number of Shots</u>	<u>Number of Natural Events</u>
A	7	
B	60	1
C	70	17
D		9
E		27
F	2	3
G	137	30
H	25	20
I	39	1
J		
K		1
L	<u>3</u>	<u> </u>
Total	343	109

Nineteen of the January surface wave events were located and plotted in figure 9 as triangles. The crosses represent all located epicenters prior to January 1, 1980. All January surface wave events, located and unlocated, are listed in the event table.

Except for 17 events between 6 and 7 a.m., January 20, the bulk of the activity runs in an arc across stations 4 and 5. This arc could delineate a new fault branching off from the north-south fault near station 5, or it could be an extension of the east-west fault which was thought to terminate near the well site. In either case the two faults appear to be growing together.

Magnitudes range from 0.52 to 1.79 and are plotted vs. cumulative frequency of occurrence for January in figure 10. It can be seen that the magnitudes of the largest events in November were greater than in January. This would be expected if strains are no longer being induced. According to Karnik (1961), a magnitude 2.5 event at 2 km depth would have an intensity of about V, which would be felt outdoors and would awaken sleepers. The relevance of Karnik's equation to the Brazoria site is not known because the signals are so

- + PRIOR TO JANUARY 1980
- △ DURING JANUARY 1980

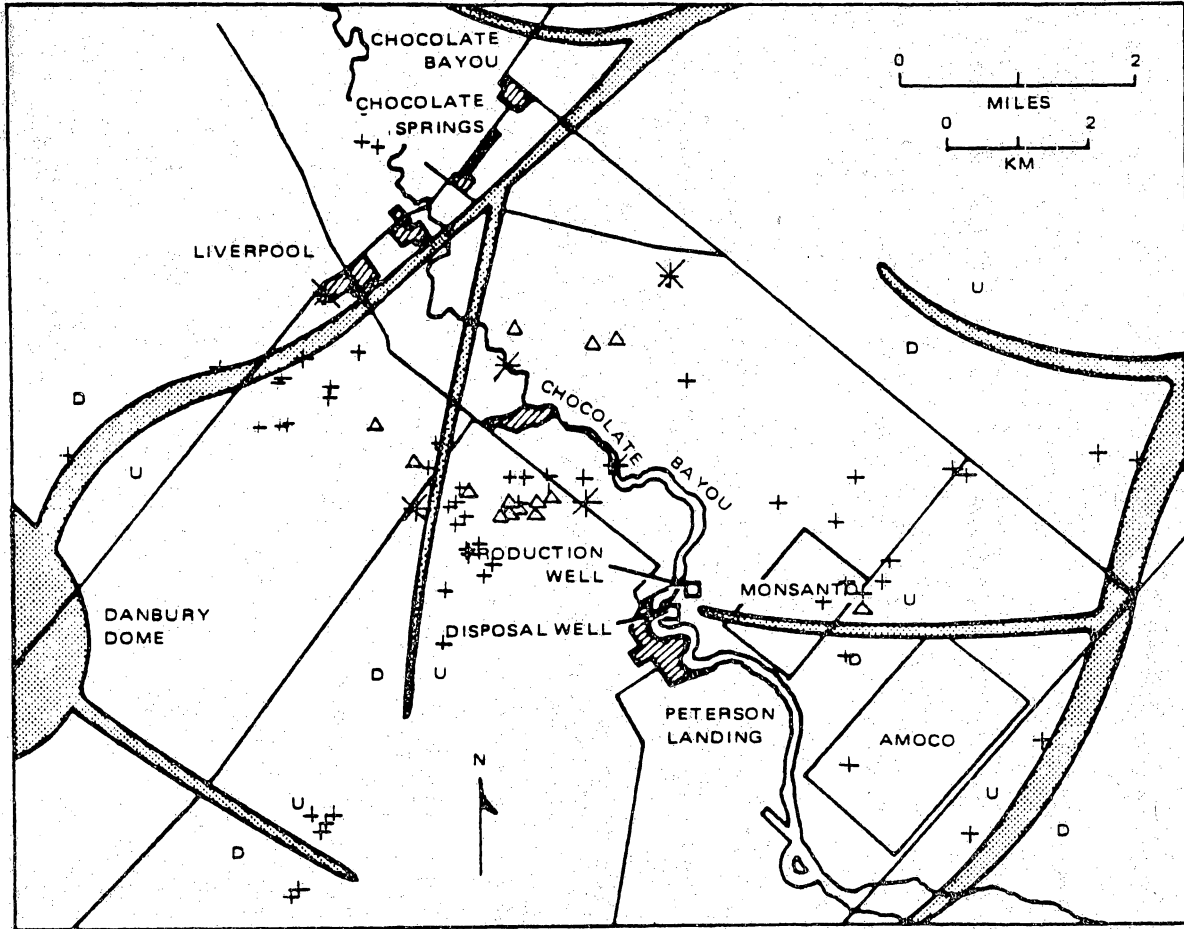

Figure 9. Natural event epicenters with growth faults at 15,000 ft depth.

Table 3. Microseismic events, January 1980.

DATE			EVENT NO.	TIME			COORDINATES		REGION	MAGNITU (MS)
YR	MO	DAY		HR	MIN	SEC	Y(KM)	X(KM)		
80	01	02	1	21	26	58.00			KL	1.43
80	01	03	2	11	22	57.80	0.472	0.066	B	1.16
80	01	03	3	12	11	0.00			G	1.05
80	01	03	4	12	18	26.22	-0.767	-0.021	GF	1.44
80	01	04	5	11	21	28.81	-3.387	4.670	D	1.79
80	01	05	6	20	51	2.32	-1.282	-1.363	G	1.50
80	01	14	7	22	12	40.63	-1.346	1.530	E	1.61
80	01	17	8	5	25	51.99	-1.805	0.510	E	1.20
80	01	17	9	5	30	0.00			E	0.90
80	01	17	10	5	32	20.00			E	0.85
80	01	17	11	5	35	10.00			E	0.83
80	01	17	12	5	36	55.93	-1.864	0.290	E	0.96
80	01	17	13	5	41	26.00			E	1.07
80	01	17	14	5	42	30.00			H	1.11
80	01	17	15	5	44	50.00			E	1.12
80	01	17	16	5	45	50.00			H	1.01
80	01	17	17	5	46	59.57	-1.649	0.515	E	1.35
80	01	17	18	5	51	10.00			E	1.29
80	01	17	19	5	53	20.00			E	1.13
80	01	17	20	5	57	40.00			E	0.99
80	01	17	21	5	59	30.84	-1.296	1.022	ED	1.14
80	01	17	22	6	2	30.00			ED	0.87
80	01	17	23	6	4	30.00			ED	1.07
80	01	17	24	6	13	25.00			ED	0.84
80	01	17	25	6	14	20.00			ED	0.73
80	01	17	26	6	19	20.00			ED	0.80
80	01	17	27	6	22	28.00			D	0.72
80	01	17	28	6	49	40.00			G	1.23
80	01	17	29	6	52	20.00			G	1.28
80	01	17	30	6	54	10.00			E	1.50
80	01	17	31	6	55	21.02	-1.852	-0.075	F	0.99
80	01	17	32	6	58	5.00			DE	0.89
80	01	17	33	7	0	10.00			DE	0.93
80	01	17	34	7	4	0.00			DE	0.83
80	01	17	35	7	13	0.00			D	0.81
80	01	17	36	7	16	30.00			D	0.67
80	01	17	37	7	25	1.78	-1.024	1.393	D	0.82
80	01	17	38	7	37	40.00			E	1.14
80	01	17	39	8	7	15.00			F	0.62
80	01	17	40	9	52	0.00			ED	0.68
80	01	17	41	11	13	10.00			D	0.52
80	01	20	42	12	4	0.00			C	0.98
80	01	20	43	12	8	20.37	0.291	1.449	C	1.17
80	01	20	44	12	11	1.18	0.256	1.111	C	1.16
80	01	20	45	12	15	20.00			C	1.03

Table 3 (continued)

DATE			EVENT NO.	TIME			COORDINATES		REGION	MAGNITUDE (MS)
YR	MO	DAY		HR	MIN	SEC	Y(KM)	X(KM)		
80	01	20	46	12	16	40.00			C	0.64
80	01	20	47	12	17	30.00			C	0.62
80	01	20	48	12	18	54.00			C	0.92
80	01	20	49	12	32	20.00			C	0.68
80	01	20	50	12	36	20.00			C	0.74
80	01	20	51	12	37	0.00			C	0.59
80	01	20	52	12	39	0.00			C	0.70
80	01	20	53	12	40	0.00			C	0.66
80	01	20	54	12	41	50.00			C	0.87
80	01	20	55	12	43	50.00			C	0.78
80	01	20	56	12	47	40.00			C	0.72
80	01	20	57	12	50	0.00			C	0.84
80	01	20	58	12	55	0.00			C	0.75
80	01	21	59	9	1	10.00			H	0.94
80	01	21	60	9	3	29.81	-1.898	-1.105	H	1.13
80	01	21	61	9	16	24.72	-0.773	-1.883	HI	1.33
80	01	21	62	9	20	44.03	-0.445	-4.400	I	1.29
80	01	21	63	9	31	25.00			HI	1.08
80	01	21	64	9	33	50.00			HI	0.72
80	01	21	65	9	39	45.00			HI	0.68
80	01	21	66	9	40	20.00			HI	0.85
80	01	21	67	9	42	10.00			HI	1.06
80	01	21	68	9	58	0.00			HI	0.75
80	01	21	69	10	6	20.00			HG	1.04
80	01	21	70	10	10	20.00			HG	0.86
80	01	21	71	10	13	40.00			HG	0.99
80	01	21	72	10	16	40.00			HI	0.78
80	01	21	73	10	17	0.00			HI	0.84
80	01	21	74	10	20	30.00			GH	0.76
80	01	21	75	10	27	30.00			GH	0.78
80	01	21	76	10	32	40.00			GH	0.72
80	01	21	77	10	36	10.00			GH	0.56
80	01	21	78	10	36	58.72	-1.736	-0.637	G	1.18
80	01	21	79	10	39	0.00			GF	0.71
80	01	21	80	10	43	40.00			GF	1.16
80	01	21	81	10	50	35.00			GH	1.21
80	01	21	82	11	2	10.74	-0.496	-0.325	GH	0.80
80	01	21	83	11	4	40.00			GH	0.88
80	01	21	84	11	5	10.00			GH	0.65
80	01	21	85	11	15	22.40	-2.032	0.264	EF	1.49
80	01	21	86	11	26	20.00			G	1.18
80	01	21	87	11	37	20.00			G	0.91
80	01	21	88	11	42	40.00			G	1.21
80	01	21	89	11	51	14.38	-1.998	-0.085	F	1.05
80	01	21	90	11	59	30.00			G	1.02
80	01	21	91	12	11	31.90	-1.959	0.034	EF	1.25
80	01	21	92	12	13	0.00			H	1.06
80	01	21	93	12	13	20.38	-1.440	-1.112	G	1.49
80	01	21	94	12	32	40.00			G	1.09
80	01	21	95	12	37	50.00			G	1.13

Table 3 (continued)

DATE			EVENT NO.	TIME			COORDINATES		REGION	MAGNITUDE (MS)
YR	MO	DAY		HR	MIN	SEC	Y(KM)	X(KM)		
80	01	21	96	12	38	10.00			G	1.12
80	01	21	97	12	43	12.81	-2.041	-0.188	GF	1.25
80	01	22	98	6	35	23.00			GF	0.97
80	01	22	99	7	16	35.00			EF	0.89
80	01	22	100	7	23	20.00			GF	0.71
80	01	22	101	7	24	35.00			GF	0.84
80	01	22	102	7	25	0.00			GF	0.77
80	01	22	103	7	29	28.00			GF	1.10
80	01	22	104	7	35	50.00			H	1.54
80	01	22	105	7	37	40.00			HG	1.13
80	01	22	106	7	38	10.00			HG	1.13
80	01	22	107	7	39	40.00			E	1.16
80	01	22	108	7	40	30.00			E	1.07
80	01	22	109	7	54	30.00			E	1.13

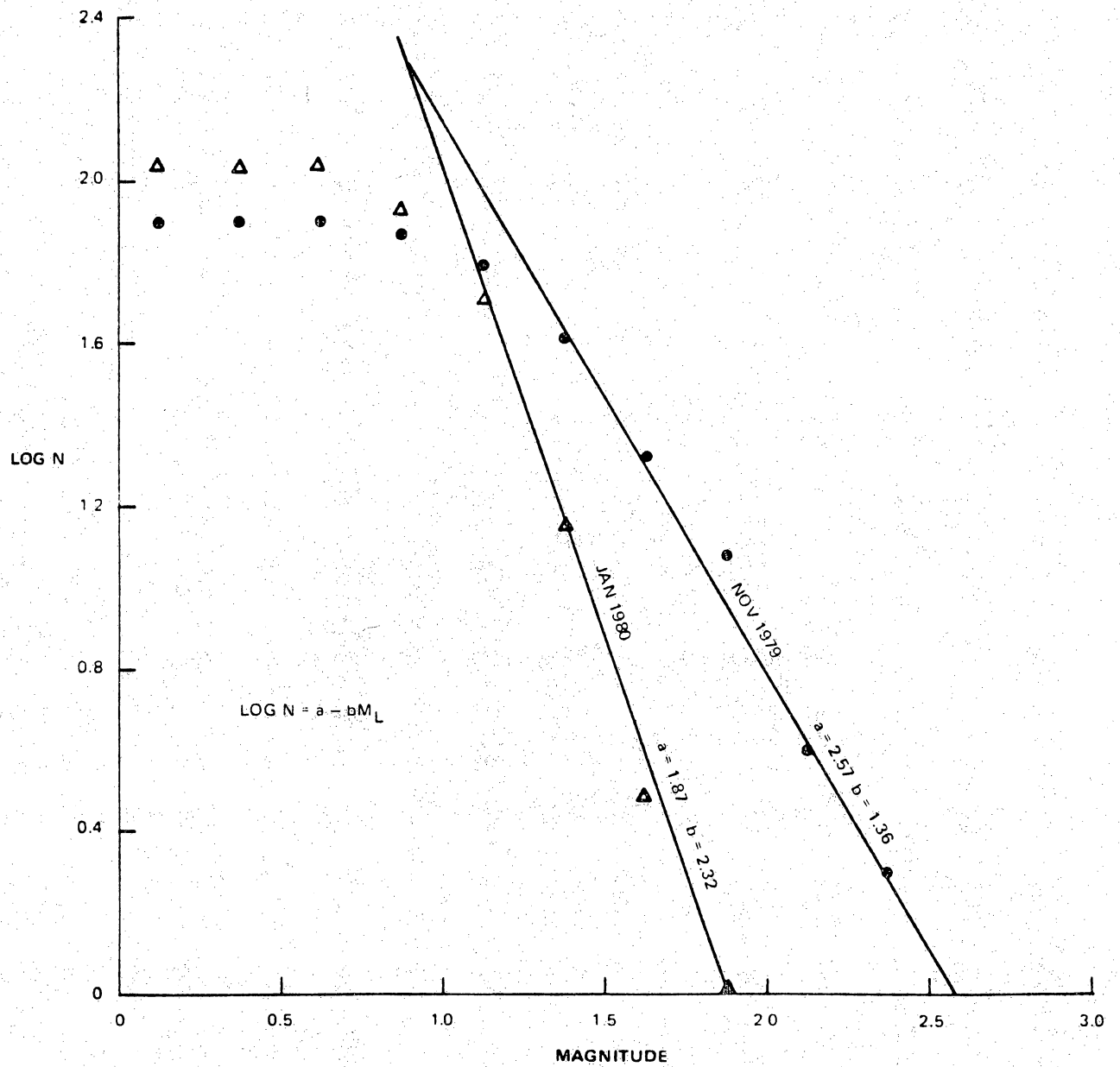

Figure 10. Cumulative frequency of occurrence vs. magnitude for November 1979 and January 1980.

unconventional, with short duration and long period, but the possibility of felt events does exist.

February

In addition to the previously defined seismic shot and surface wave events, a third class of signals was identified during February. These have apparent velocities as slow as the surface waves but very impulsive starts similar to the seismic shots. Their distribution in time is summarized in table 4.

Table 4. "Impulsive event" summary.

<u>Date</u>	<u>Time (Local)</u>	<u>No. of Events</u>	<u>Region</u>
January 20	6:04 - 6:55 a.m.	17	C
February 4	5:55 p.m.	1	D
February 5	5:27 p.m.	1	D
February 5-6	10:47 p.m. - 12:40 a.m.	246	D
February 6	9:00 - 9:45 p.m.	18	D
February 12	12:30 - 12:37 a.m.	379	D
February 12	11:50 p.m.	1	C
February 13-14	10:01 p.m. - 1:28 a.m.	7	C

The 17 events on January 20 were also of this type. More than 600 events occurred over short time periods at 10:45 p.m. February 5 and at 12:30 a.m. on February 12. Figure 11 is a representative sample of one of these records. The consistent appearance of these waveforms implies either a cultural source or multiple displacements on the same fault surface. Fluid injection at shallow depths could induce such activity. Epicenter locations place at least some of the activity at the petrochemical plants, as shown in figure 12, but of course these locations are only estimates.

Inquiries at the Chocolate Bayou Corporation and the Parker Bros. Company failed to yield any information on unusual nighttime activity in the area. At

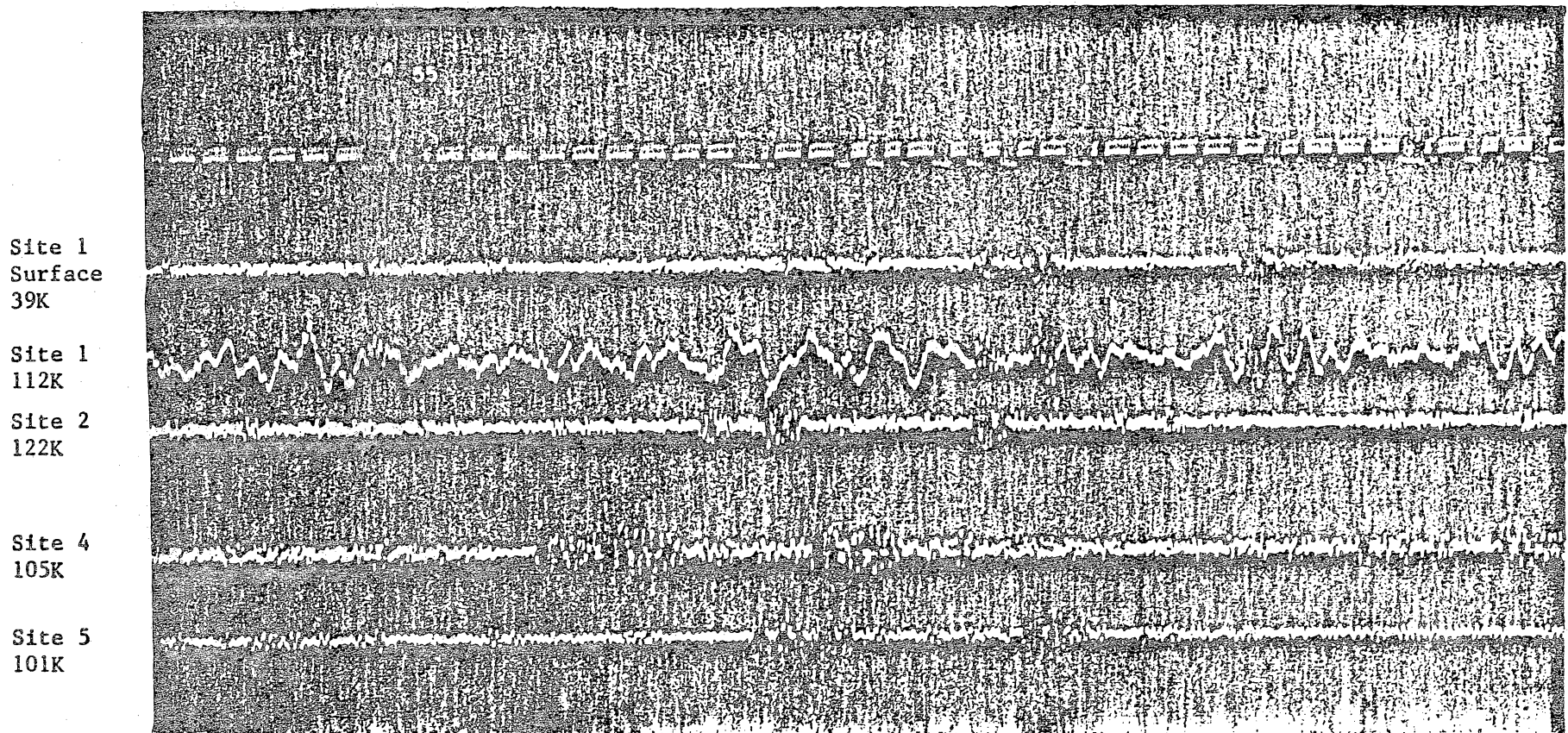

Figure 11. Typical record from night of February 5-6.

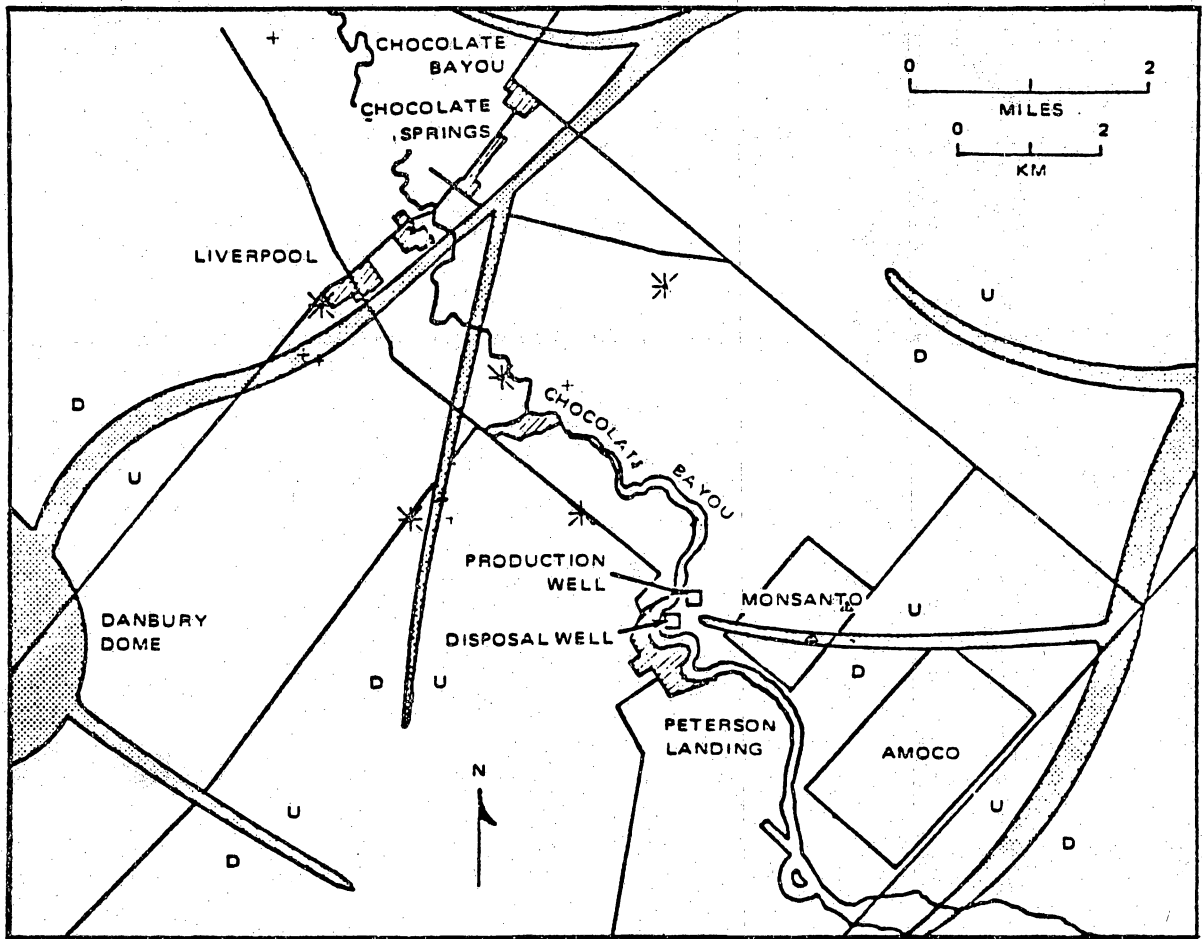

Figure 12. Epicenters determined for February 1980 (after White et al., 1978).

Table 5. Microseismic events, February 1980.

DATE			EVENT NO.	TIME			COORDINATES		REGION	MAGNITUDE (MS)
YR	MO	DAY		HR	MIN	SEC	Y(KM)	X(KM)		
80	02	01	1	18	54	43.48	7.680	0.398	L	1.88
80	02	01	2	19	16	40.00			I	1.99
80	02	01	3	19	20	40.00			KJ	1.69
80	02	01	4	19	21	10.00			KJ	1.88
80	02	01	5	19	21	40.00			KJ	1.74
80	02	02	6	13	55	0.00			A	1.70
80	02	02	7	19	15	10.00			G	1.59
80	02	02	8	20	24	45.24	-1.662	-0.845	G	1.34
80	02	02	9	20	25	26.53	-1.555	-0.800	G	1.34
80	02	02	10	20	27	5.29	-1.633	-0.823	G	1.57
80	02	02	11	20	27	50.00			G	0.99
80	02	02	12	21	9	2.28	-1.166	-0.662	G	1.46
80	02	02	13	21	10	20.00			G	1.04
80	02	02	14	21	11	3.77	-1.901	-0.723	G	1.47
80	02	04	15	23	55	22.55	-3.619	4.104	D	1.91
80	02	05	16	23	27	0.00			D	1.00
80	02	06	17	4	47	2.00			D	1.84
80	02	06	18	4	47	23.00			D	1.65
80	02	06	19	4	48	20.00			D	1.58
80	02	06	20	4	48	32.00			D	1.58
80	02	06	21	4	48	52.00			D	1.35
80	02	06	22	4	48	54.00			D	1.55
80	02	06	23	4	48	58.00			D	1.75
80	02	06	24	4	49	10.00			D	1.81
80	02	06	25	4	49	24.00			D	1.47
80	02	06	26	4	49	33.00			D	1.47
80	02	06	27	4	49	40.00			D	1.47
80	02	06	28	4	49	50.00			D	1.47
80	02	06	29	4	49	56.00			D	1.73
80	02	06	30	4	50	5.00			D	1.55
80	02	06	31	4	50	7.00			D	1.55
80	02	06	32	4	50	12.00			D	1.55
80	02	06	33	4	50	16.00			D	1.69
80	02	06	34	4	50	18.00			D	1.55
80	02	06	35	4	50	25.00			D	1.73
80	02	06	36	4	50	29.00			D	1.65
80	02	06	37	4	50	34.00			D	1.49
80	02	06	38	4	50	38.00			D	1.90
80	02	06	39	4	50	58.00			D	1.65
80	02	06	40	4	51	5.00			D	1.65
80	02	06	41	4	51	13.00			D	1.65
80	02	06	42	4	51	34.00			D	1.65
80	02	06	43	4	53	0.00			D	1.85
80	02	06	44	4	53	8.00			D	1.85
80	02	06	45	4	53	14.00			D	1.85

Table 5 (continued)

DATE			EVENT NO.	TIME			COORDINATES		REGION	MAGNITUDE (MS)
YR	MO	DAY		HR	MIN	SEC	Y(KM)	X(KM)		
80	02	06	46	4	53	37.00			D	1.60
80	02	06	47	4	53	42.00			D	1.83
80	02	06	48	4	53	57.00			D	1.69
80	02	06	49	4	54	12.00			D	1.88
80	02	06	50	4	54	16.00			D	1.69
80	02	06	51	4	54	20.00			D	1.98
80	02	06	52	4	54	36.00			D	1.80
80	02	06	53	4	54	45.00			D	1.69
80	02	06	54	4	55	4.00			D	1.90
80	02	06	55	4	55	6.00			D	1.90
80	02	06	56	4	55	12.00			D	1.90
80	02	06	57	4	56	25.00			D	2.01
80	02	06	58	4	57	7.00			D	1.85
80	02	06	59	4	57	53.00			D	1.73
80	02	06	60	4	58	13.00			D	1.73
80	02	06	61	4	58	15.00			D	1.73
80	02	06	62	4	58	49.00			D	1.80
80	02	06	63	4	59	25.00			D	1.73
80	02	06	64	5	0	16.82	-1.284	1.750	D	1.63
80	02	06	65	5	0	35.97	-2.047	2.588	D	1.64
80	02	06	66	5	0	51.00			D	1.55
80	02	06	67	5	1	0.00			D	1.55
80	02	06	68	5	1	6.00			D	1.55
80	02	06	69	5	1	14.00			D	1.55
80	02	06	70	5	1	48.00			D	1.96
80	02	06	71	5	2	52.00			D	2.01
80	02	06	72	5	3	51.00			D	1.60
80	02	06	73	5	4	9.00			D	1.60
80	02	06	74	5	4	28.00			D	1.80
80	02	06	75	5	4	34.00			D	1.80
80	02	06	76	5	4	43.00			D	1.55
80	02	06	77	5	4	52.00			D	1.55
80	02	06	78	5	4	55.00			D	1.55
80	02	06	79	5	7	19.00			D	1.95
80	02	06	80	5	7	26.00			D	1.80
80	02	06	81	5	7	33.00			D	1.95
80	02	06	82	5	7	57.00			D	1.77
80	02	06	83	5	7	59.00			D	1.73
80	02	06	84	5	8	9.00			D	1.95
80	02	06	85	5	8	14.00			D	1.95
80	02	06	86	5	11	27.00			D	1.95
80	02	06	87	5	11	32.00			D	1.83
80	02	06	88	5	13	49.00			D	1.65
80	02	06	89	5	14	10.00			D	1.85
80	02	06	90	5	14	24.00			D	1.90

Table 5 (continued)

DATE			EVENT NO.	TIME			COORDINATES		REGION	MAGNITUDE (MS)
YR	MO	DAY		HR	MIN	SEC	Y(KM)	X(KM)		
80	02	06	91	5	14	38.00			D	1.95
80	02	06	92	5	20	57.00			D	1.85
80	02	06	93	5	21	50.00			D	1.85
80	02	06	94	5	23	29.00			D	1.88
80	02	06	95	5	23	39.00			D	1.85
80	02	06	96	5	25	55.00			D	1.69
80	02	06	97	5	26	3.00			D	1.55
80	02	06	98	5	26	8.00			D	1.55
80	02	06	99	5	26	19.00			D	1.90
80	02	06	100	5	26	33.00			D	1.73
80	02	06	101	5	26	38.00			D	1.73
80	02	06	102	5	26	45.00			D	1.73
80	02	06	103	5	26	49.00			D	1.73
80	02	06	104	5	27	18.00			D	1.76
80	02	06	105	5	27	30.00			D	1.95
80	02	06	106	5	27	32.00			D	1.95
80	02	06	107	5	27	36.00			D	1.95
80	02	06	108	5	27	44.00			D	1.85
80	02	06	109	5	27	51.00			D	1.85
80	02	06	110	5	27	53.00			D	1.85
80	02	06	111	5	28	24.00			D	1.73
80	02	06	112	5	28	26.00			D	1.60
80	02	06	113	5	28	29.00			D	1.95
80	02	06	114	5	28	34.00			D	1.60
80	02	06	115	5	29	12.00			D	1.99
80	02	06	116	5	30	46.00			D	1.85
80	02	06	117	5	31	18.00			D	1.76
80	02	06	118	5	31	28.00			D	2.08
80	02	06	119	5	31	39.00			D	1.90
80	02	06	120	5	33	45.00			D	1.85
80	02	06	121	5	34	5.00			D	1.85
80	02	06	122	5	34	15.00			D	1.65
80	02	06	123	5	34	19.00			D	1.80
80	02	06	124	5	34	25.00			D	1.90
80	02	06	125	5	34	32.00			D	1.55
80	02	06	126	5	34	58.00			D	1.55
80	02	06	127	5	35	6.00			D	1.55
80	02	06	128	5	35	7.00			D	1.55
80	02	06	129	5	35	26.00			D	1.69
80	02	06	130	5	35	28.00			D	1.69
80	02	06	131	5	35	30.00			D	1.55
80	02	06	132	5	35	32.00			D	1.55
80	02	06	133	5	35	34.00			D	1.55
80	02	06	134	5	35	36.00			D	1.55
80	02	06	135	5	35	50.00			D	1.73

Table 5 (continued)

DATE			EVENT NO.	TIME			COORDINATES		REGION	MAGNITUDE (MS)
YR	MO	DAY		HR	MIN	SEC	Y(KM)	X(KM)		
80	02	06	136	5	37	0.00			D	1.73
80	02	06	137	5	37	29.00			D	1.65
80	02	06	138	5	37	38.00			D	1.80
80	02	06	139	5	37	40.00			D	1.55
80	02	06	140	5	37	46.00			D	1.65
80	02	06	141	5	38	20.00			D	1.65
80	02	06	142	5	38	35.00			D	1.80
80	02	06	143	5	38	57.00			D	1.55
80	02	06	144	5	38	58.00			D	1.90
80	02	06	145	5	39	3.00			D	1.55
80	02	06	146	5	39	8.00			D	2.11
80	02	06	147	5	39	21.00			D	1.88
80	02	06	148	5	40	44.00			D	1.88
80	02	06	149	5	40	47.00			D	1.88
80	02	06	150	5	41	4.00			D	1.88
80	02	06	151	5	41	6.00			D	1.88
80	02	06	152	5	41	9.00			D	1.88
80	02	06	153	5	41	38.00			D	1.88
80	02	06	154	5	42	13.00			D	1.69
80	02	06	155	5	42	17.00			D	1.80
80	02	06	156	5	42	22.00			D	1.69
80	02	06	157	5	42	29.00			D	1.80
80	02	06	158	5	42	54.00			D	1.69
80	02	06	159	5	42	58.00			D	1.49
80	02	06	160	5	43	0.00			D	1.49
80	02	06	161	5	43	12.00			D	1.80
80	02	06	162	5	43	24.00			D	1.88
80	02	06	163	5	43	29.00			D	1.88
80	02	06	164	5	43	30.00			D	1.88
80	02	06	165	5	43	35.00			D	2.01
80	02	06	166	5	43	40.00			D	1.80
80	02	06	167	5	44	10.00			D	1.95
80	02	06	168	5	44	24.00			D	1.95
80	02	06	169	5	44	44.00			D	1.85
80	02	06	170	5	45	10.00			D	1.95
80	02	06	171	5	45	13.00			D	1.95
80	02	06	172	5	48	37.00			D	1.85
80	02	06	173	5	48	41.00			D	1.65
80	02	06	174	5	48	43.00			D	1.65
80	02	06	175	5	48	46.00			D	1.85
80	02	06	176	5	49	9.00			D	1.80
80	02	06	177	5	49	19.00			D	1.65
80	02	06	178	5	49	39.00			D	1.95
80	02	06	179	5	50	39.00			D	1.95
80	02	06	180	5	53	50.00			D	2.06

Table 5 (continued)

DATE			EVENT NO.	TIME			COORDINATES		REGION	MAGNITUDE (MS)
YR	MO	DAY		HR	MIN	SEC	Y(KM)	X(KM)		
80	02	06	181	5	54	01.00			D	1.73
80	02	06	182	5	54	35.00			D	1.93
80	02	06	183	5	54	54.00			D	1.85
80	02	06	184	5	55	42.00			D	1.88
80	02	06	185	5	55	52.00			D	1.80
80	02	06	186	5	56	2.00			D	1.60
80	02	06	187	5	57	37.00			D	1.93
80	02	06	188	5	57	39.00			D	2.13
80	02	06	189	5	57	45.00			D	1.65
80	02	06	190	5	57	47.00			D	1.55
80	02	06	191	5	58	16.00			D	1.80
80	02	06	192	5	58	27.00			D	1.83
80	02	06	193	5	58	31.00			D	1.85
80	02	06	194	5	59	10.00			D	1.88
80	02	06	195	5	59	28.00			D	1.88
80	02	06	196	5	59	42.00			D	1.83
80	02	06	197	5	59	59.00			D	1.83
80	02	06	198	6	0	20.00			D	1.97
80	02	06	199	6	0	40.00			D	1.88
80	02	06	200	6	1	16.00			D	1.85
80	02	06	201	6	1	40.00			D	1.65
80	02	06	202	6	2	3.00			D	1.93
80	02	06	203	6	2	7.00			D	1.76
80	02	06	204	6	2	13.00			D	1.73
80	02	06	205	6	2	17.00			D	1.76
80	02	06	206	6	2	46.00			D	1.76
80	02	06	207	6	3	2.00			D	1.73
80	02	06	208	6	3	19.00			D	1.73
80	02	06	209	6	3	26.00			D	1.65
80	02	06	210	6	3	32.00			D	1.65
80	02	06	211	6	3	37.00			D	1.83
80	02	06	212	6	3	42.00			D	1.83
80	02	06	213	6	4	49.00			D	1.83
80	02	06	214	6	5	0.00			D	1.90
80	02	06	215	6	5	2.00			D	1.95
80	02	06	216	6	5	4.00			D	1.90
80	02	06	217	6	5	17.00			D	1.73
80	02	06	218	6	5	29.00			D	1.65
80	02	06	219	6	5	40.00			D	1.99
80	02	06	220	6	5	57.00			D	1.80
80	02	06	221	6	5	59.00			D	1.80
80	02	06	222	6	6	9.00			D	1.65
80	02	06	223	6	6	59.00			D	1.97
80	02	06	224	6	7	54.00			D	1.85
80	02	06	225	6	7	58.00			D	1.76

Table 5 (continued)

DATE			EVENT NO.	TIME			COORDINATES		REGION	MAGNITUDE (MS)
YR	MO	DAY		HR	MIN	SEC	Y(KM)	X(KM)		
80	02	06	226	6	8	6.00			D	1.76
80	02	06	227	6	9	8.00			D	1.65
80	02	06	228	6	11	14.00			D	1.85
80	02	06	229	6	11	20.00			D	1.85
80	02	06	230	6	11	26.00			D	1.85
80	02	06	231	6	11	28.00			D	1.85
80	02	06	232	6	11	30.00			D	1.85
80	02	06	233	6	12	32.00			D	1.55
80	02	06	234	6	12	34.00			D	1.60
80	02	05	235	6	12	46.00			D	1.85
80	02	05	236	6	12	50.00			D	1.65
80	02	05	237	6	12	53.00			D	1.97
80	02	05	238	6	13	33.00			D	1.85
80	02	05	239	6	13	35.00			D	1.65
80	02	05	240	6	13	56.00			D	1.95
80	02	05	241	6	14	19.00			D	1.83
80	02	05	242	6	15	27.00			D	1.65
80	02	05	243	6	15	36.00			D	1.80
80	02	05	244	6	15	49.00			D	2.06
80	02	05	245	6	16	17.00			D	2.10
80	02	05	246	6	16	23.00			D	1.95
90	02	05	247	6	16	38.00			D	1.90
80	02	05	248	6	17	12.00			D	1.88
80	02	05	249	6	17	16.00			D	1.90
80	02	05	250	6	17	22.00			D	1.85
80	02	05	251	6	18	12.00			D	1.76
80	02	05	252	6	18	21.00			D	1.83
80	02	05	253	6	18	27.00			D	1.95
80	02	05	254	6	18	39.00			D	1.73
80	02	05	255	6	18	59.00			D	1.90
80	02	05	256	6	20	27.00			D	1.60
80	02	05	257	6	40	35.00			D	1.49
80	02	05	258	6	40	44.00			D	1.49
80	02	05	259	6	40	46.00			D	1.49
80	02	05	260	6	40	53.00			D	1.65
80	02	06	261	17	14	4.84	4.649	-2.959	KJ	1.93
80	02	06	262	19	59	5.00			D	0.82
80	02	06	263	20	8	30.00			D	0.76
80	02	07	264	3	1	32.00			D	1.51
80	02	07	265	3	1	37.00			D	1.59
80	02	07	266	3	2	4.00			D	1.82
80	02	07	267	3	2	5.00			D	1.72
80	02	07	268	3	2	41.00			D	1.57
80	02	07	269	3	2	47.00			D	1.69
80	02	07	270	3	2	51.00			D	1.49

Table 5 (continued)

DATE			EVENT NO.	TIME			COORDINATES		REGION	MAGNITUDE (MS)
YR	MO	DAY		HR	MIN	SEC	Y(KM)	X(KM)		
80	02	07	271	3	2	59.00			D	1.65
80	02	07	272	3	3	7.00			D	1.55
80	02	07	273	3	3	8.00			D	1.61
80	02	07	274	3	3	21.00			D	1.58
80	02	07	275	3	3	26.00			D	1.47
80	02	07	276	3	3	30.00			D	1.42
80	02	07	277	3	3	38.00			D	1.81
80	02	07	278	3	4	29.00			D	1.73
80	02	07	279	3	4	40.00			D	1.60
80	02	08	280	14	49	5.00			G	1.55
80	02	09	281	0	48	8.00			DC	0.99
80	02	11	282	13	48	53.84	0.285	-2.459	IJ	1.56
379 EVENTS:										
80	02	12		630-637			-3.23	4.59	D	1.3-1.6
80	02	12	283	9	30	46.00			CD	0.58
80	02	12	284	9	42	16.00			D	0.46
80	02	12	285	9	42	32.00			D	0.58
80	02	12	286	9	53	54.00			D	0.46
80	02	12	287	9	54	6.73	-0.135	0.900	D	0.64
80	02	12	288	9	54	20.00			D	0.64
80	02	12	289	19	38	25.67	0.366	-2.683	I	1.75
80	02	12	290	19	44	28.00			JK	2.16
80	02	12	291	19	44	47.00			JK	2.16
80	02	12	292	19	45	23.00			JK	2.02
80	02	12	293	22	39	31.00			JK	1.97
80	02	12	294	22	40	3.00			JK	2.00
80	02	12	295	22	40	38.00			JK	1.90
80	02	12	296	22	54	5.00			JK	1.86
80	02	12	297	22	54	43.00			JK	1.90
80	02	13	298	5	50	46.00			C	0.98
80	02	14	299	4	1	25.00			C	0.95
80	02	14	300	4	6	52.78	-0.102	3.614	C	0.97
80	02	14	301	6	41	48.00			C	0.92
80	02	14	302	7	10	40.00			C	0.84
80	02	14	303	7	18	58.00			C	0.92
80	02	14	304	7	23	53.00			C	0.92
80	02	14	305	7	28	4.00			C	0.84
80	02	15	306	18	33	50.00			I	1.31
80	02	15	307	18	34	5.00			I	1.69
80	02	15	308	18	34	45.00			IJ	1.43
80	02	15	309	18	35	0.00			J	1.83
80	02	15	310	18	35	10.00			J	1.60
80	02	27	311	13	17	59.00			I	1.70
80	02	27	312	13	18	18.00			I	1.93
80	02	27	313	13	19	55.00			I	1.68

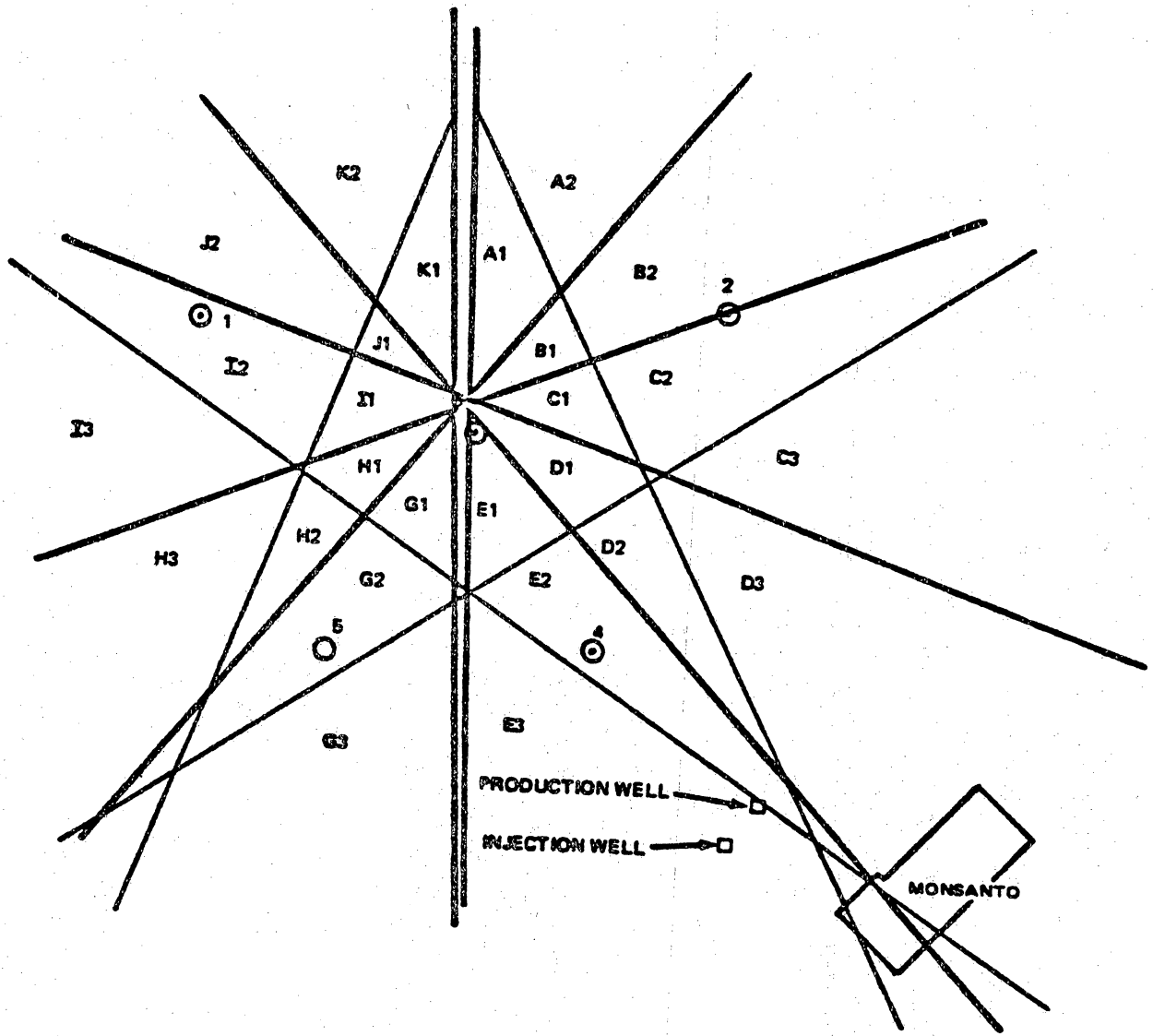

Figure 13. Epicentral regions and station locations.

present the sources of these signals could be some type of machinery, injection induced fractures or sources of some other type. The five epicenters obtained are plotted in figure 12 as triangles.

Also observed during February were forty-three surface wave signals of the emergent type which are presumed to be due to fault displacements at depth. They are included in the event list. Ten of these were located and plotted in figure 12 as crosses. Most of these epicenters lie in areas of previous activity near two known growth faults. The others are farther north and could represent a migration of activity to faults in that direction.

March

Epicenters obtained for the March activity are plotted in figure 14 and all events are listed in the event list. The events on March 4 are part of a sequence of 51 impulsive events from 1134-1147 GMT which come from the direction of the petrochemical plants. Velocity uncertainty is such that they could locate at either Monsanto or Amoco. Single events occurred on March 6 and 17 which could be near the surface exposure of mapped growth faults. Two events on March 18 are in a region of considerable past activity and have the now familiar long duration and emergent nature. These are thought to have more multipathing and dispersion because of greater source depth.

Except for the short bursts of very high activity which apparently are culturally induced, the seismicity of the area seems to be continuing to decline.

April

One event on April 23 appeared to be of the natural type. Two very long duration signals were recorded on the 16th which were located at the southwestern

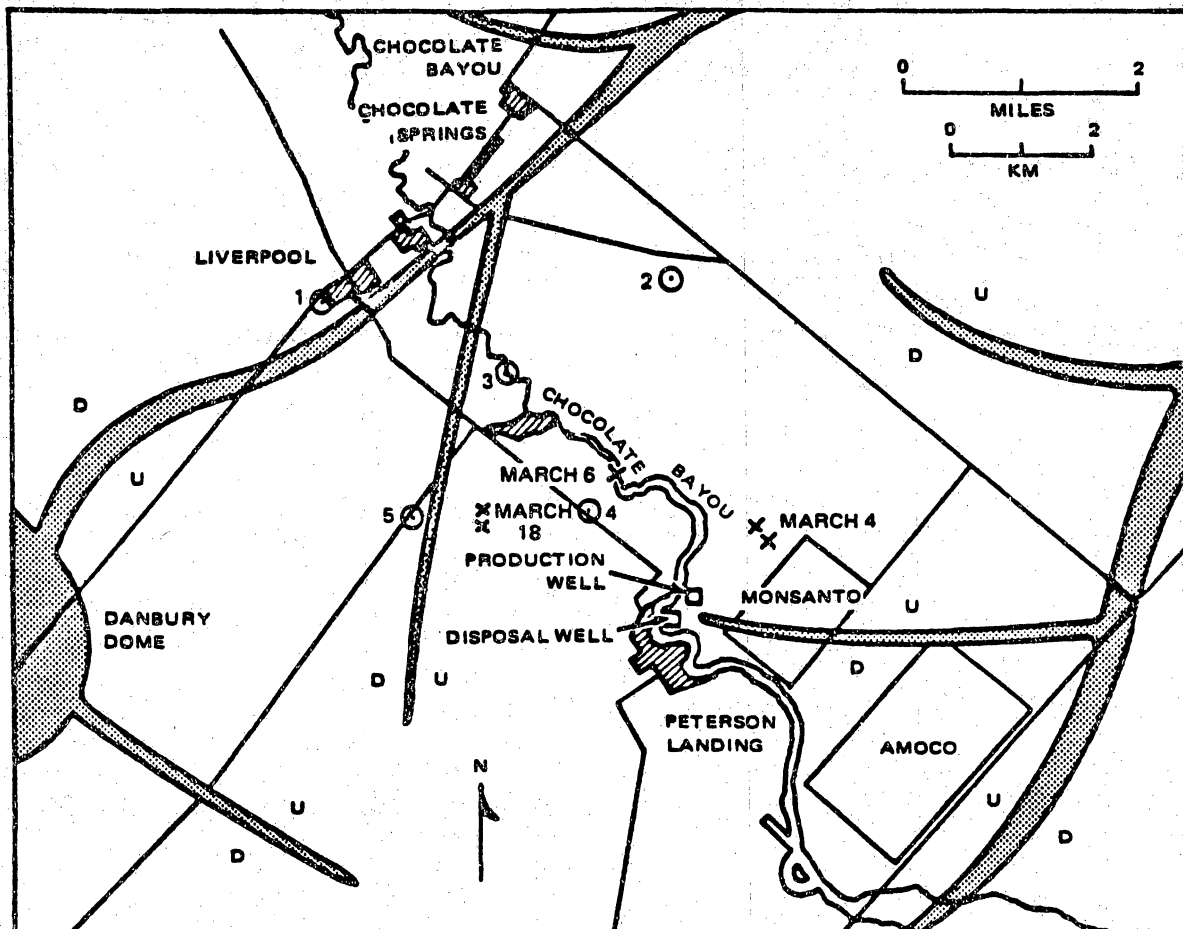

Figure 14. March 1980 epicenters.

Table 6. Microseismic events, March 1980.

DATE			EVENT NO.	TIME			COORDINATES		REGION	MAGNITUDE (MS)
YR	MO	DAY		HR	MIN	SEC	Y(KM)	X(KM)		
80	03	04	1	11	34	21.14	-2.322	3.505	D	1.27
80	03	04	2	11	34	41.00			D	1.34
80	03	04	3	11	34	52.00			D	1.34
80	03	04	4	11	35	7.00			D	1.34
80	03	04	5	11	35	12.00			D	1.19
80	03	04	6	11	35	30.00			D	1.27
80	03	04	7	11	35	34.00			D	1.27
80	03	04	8	11	35	46.00			D	1.23
80	03	04	9	11	36	8.00			D	1.23
80	03	04	10	11	36	12.00			D	1.19
80	03	04	11	11	36	19.00			D	1.23
80	03	04	12	11	36	21.00			D	1.27
80	03	04	13	11	36	42.00			D	1.19
80	03	04	14	11	37	5.00			D	1.14
80	03	04	15	11	37	17.00			D	1.19
80	03	04	16	11	37	20.00			D	1.19
80	03	04	17	11	37	39.00			D	1.19
80	03	04	18	11	37	41.00			D	1.19
80	03	04	19	11	37	49.00			D	1.19
80	03	04	20	11	38	0.00			D	1.27
80	03	04	21	11	38	3.00			D	1.27
80	03	04	22	11	38	8.00			D	1.27
80	03	04	23	11	38	9.00			D	1.19
80	03	04	24	11	38	14.00			D	1.19
80	03	04	25	11	38	45.00			D	1.14
80	03	04	26	11	38	47.25	-2.181	3.345	D	1.31
80	03	04	27	11	38	57.00			D	1.19
80	03	04	28	11	39	14.00			D	1.19
80	03	04	29	11	39	27.00			D	1.19
80	03	04	30	11	39	34.00			D	1.14
80	03	04	31	11	39	52.00			D	1.19
80	03	04	32	11	39	56.00			D	1.19
80	03	04	33	11	40	10.00			D	1.14
80	03	04	34	11	40	27.00			D	1.09
80	03	04	35	11	40	37.00			D	1.14
80	03	04	36	11	40	48.00			D	1.09
80	03	04	37	11	40	58.00			D	1.09
80	03	04	38	11	41	2.00			D	1.09
80	03	04	39	11	41	18.00			D	1.23
80	03	04	40	11	41	37.00			D	1.09
80	03	04	41	11	41	42.00			D	1.09
80	03	04	42	11	41	55.00			D	1.14
80	03	04	43	11	41	56.00			D	1.14
80	03	04	44	11	42	12.00			D	1.14
80	03	04	45	11	42	32.00			D	1.14

Table 6 (continued)

DATE			EVENT NO.	TIME			COORDINATES		REGION	MAGNITUDE (MS)
YR	MO	DAY		HR	MIN	SEC	Y(KM)	X(KM)		
80	03	04	46	11	42	42.00			D	1.23
80	03	04	47	11	43	11.00			D	1.04
80	03	04	48	11	43	31.00			D	1.09
80	03	04	49	11	44	52.00			D	1.09
80	03	04	50	11	45	46.00			D	1.09
80	03	04	51	11	47	13.00			D	1.09
80	03	06	52	11	10	30.26	-1.431	1.463	ED	1.59
80	03	17	53	12	0	40.19	8.203	2.370	A	1.93
80	03	18	54	21	19	12.19	-2.277	-0.436	G	1.39
80	03	18	55	21	19	13.57	-1.882	-0.336	G	1.33

Table 7. Microseismic events, April 1980.

DATE			EVENT NO.	TIME			COORDINATES		DEPTH (KM)	MAGNITUDE (M) S
YR	MO	DAY		HR	MIN	SEC	Y(KM)	X(KM)		
EXPLOSION:										
80	04	16	1	14	17	17.96	-4.176	3.248	0.001	1.42
NATURAL EVENT:										
80	04	23	2	20	12	52.66	0.353	3.571	0.001	1.37

edge of the Monsanto plant (figure 15). The near-acoustic velocity of 315 m/sec used for locating natural events also provided a good fit for arrival times for these events. It was later learned that local residents reported hearing two explosions that morning from the direction of the plant.

Thus, it appears that the level of activity has continued to decline since January.

May

After three months of low growth fault activity 103 growth fault events were recorded in May. The fourteen located epicenters are plotted in figure 15 and lie on or near at least three different faults. Also indicated in figure 16 are sources of suspected pump noise and hydraulic fracturing signals observed during May. The event list includes natural events and hydraulic fracture sequences.

Figure 17 is a cumulative plot of epicenters for the entire recording period of September 1978 through May 1980. The model velocity was 330 m/sec which was found to give slightly smaller residual errors than the 315 m/sec used previously.

The substantial increase in seismic rates may have some correlation with a change in local waste injection rates, but these rates are unknown.

June

During the month of June 24 natural type events were cataloged, 10 of which had locatable epicenters as plotted in figure 18. There was also a possible hydraulic fracturing sequence which was located 1 km NW of the Monsanto plant. Uncertainty in this location was such that the seismic source may have been below the plant.

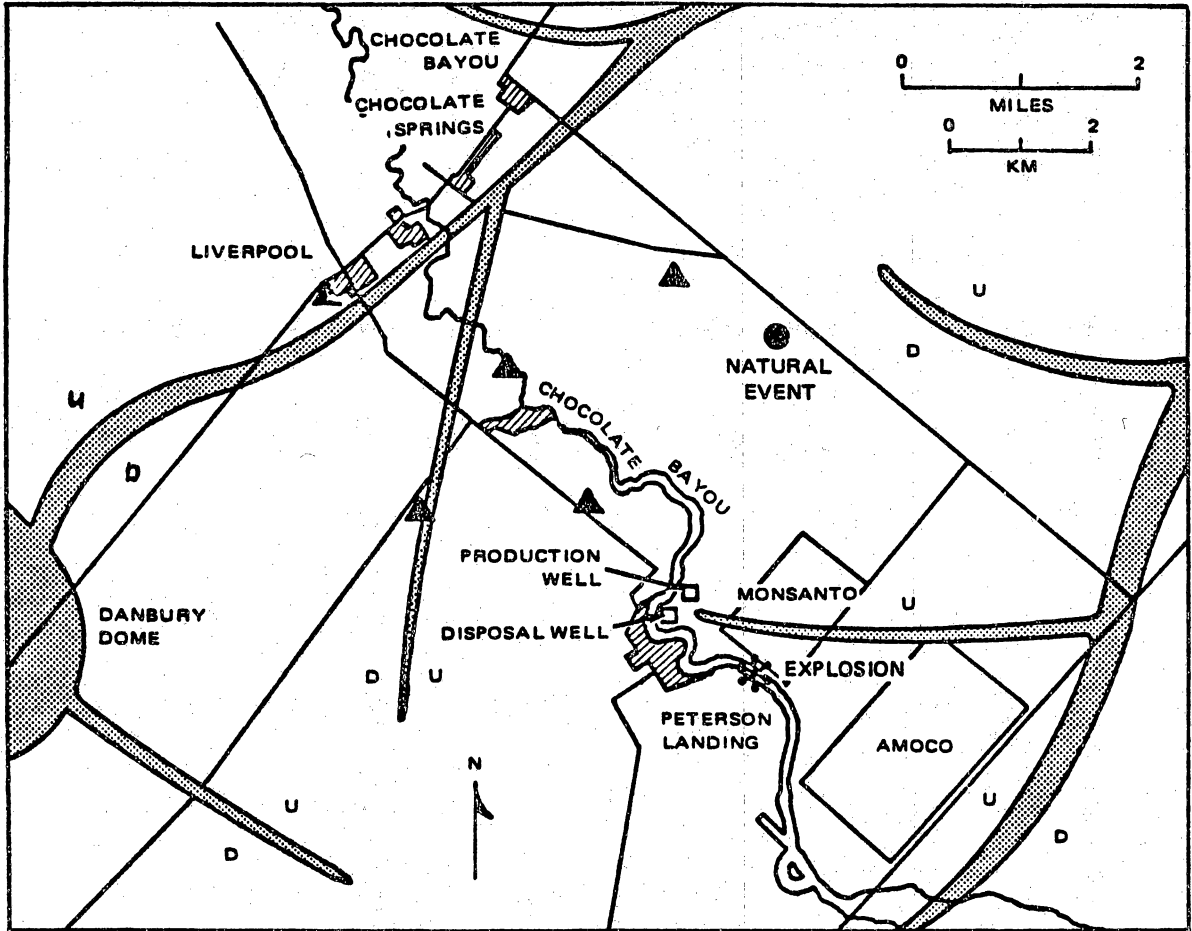

Figure 15. April 1980 epicenters.

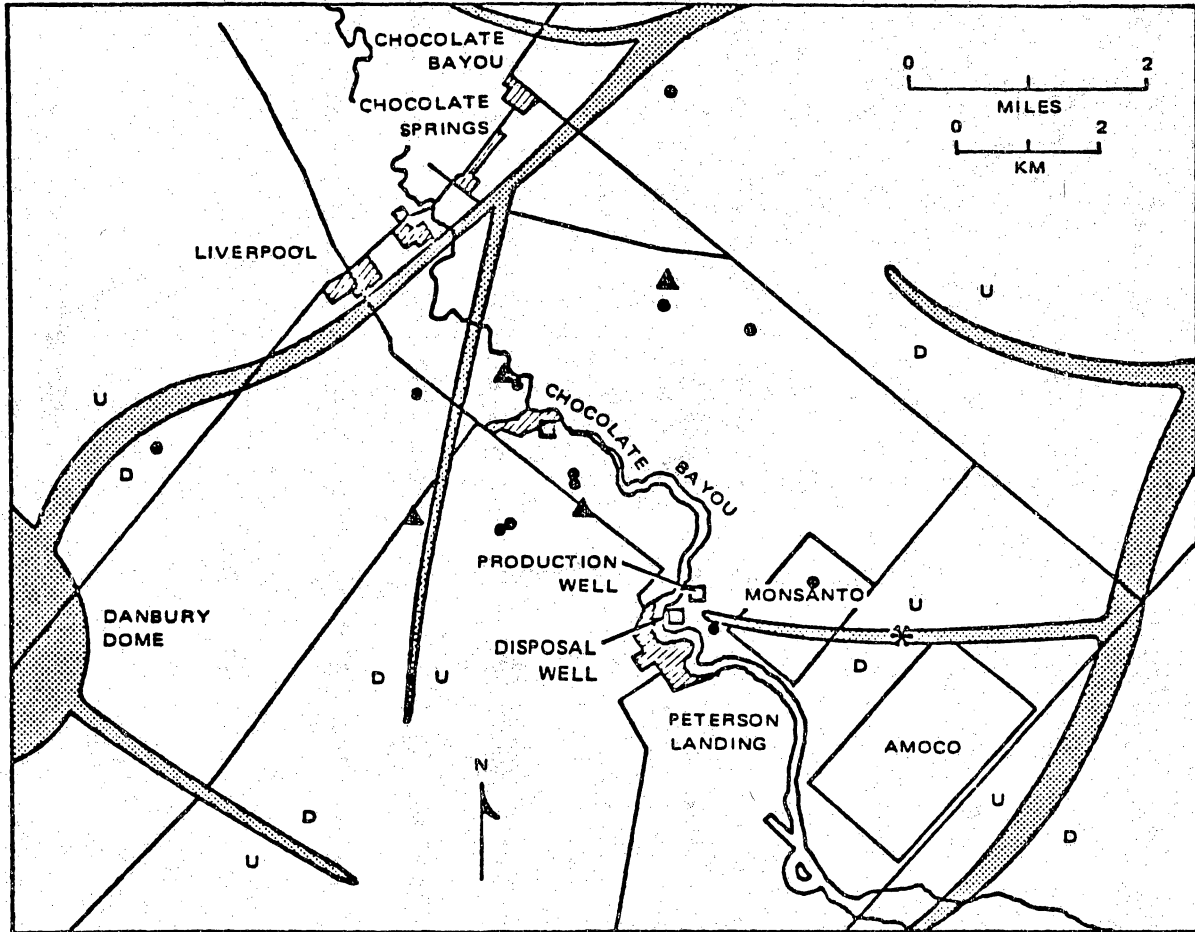

Figure 16. Epicenter map for May 1980.

Table 8. Microseismic events, May 1980.

DATE			EVENT NO.	TIME			COORDINATES		REGION	MAGNITUDE (MS)
YR	MO	DAY		HR	MIN	SEC	Y(KM)	X(KM)		
80	05	05	1	5	17	31.00			B	1.31
80	05	05	2	5	20	8.00			B	1.43
80	05	05	3	5	22	17.89	0.854	2.188	B	1.58
25 HYDROFRACTURES:										
80	05	06		0708-0717			-3.639	5.274	D	1.85
80	05	08	4	5	32	9.59	0.646	-0.055	A	1.64
6 HYDROFRACTURES:										
80	05	08		0724-0741					D	
80	05	08	5	18	32	32.53	-1.513	0.913	E	1.72
80	05	08	6	19	13	9.02	-0.142	0.158	C	1.47
80	05	08	7	19	26	21.00			D	1.94
80	05	08	8	19	34	51.00			H	0.71
80	05	08	9	19	48	23.00			H	0.79
80	05	08	10	20	15	6.95	3.724	2.349	A	1.92
80	05	08	11	20	19	12.00			E	1.50
80	05	08	12	20	23	7.51	0.483	3.360	C	1.87
80	05	08	13	20	27	0.00			B	1.24
80	05	08	14	20	29	2.00			E	1.31
80	05	09	15	17	53	0.00			J	0.91
19 HYDROFRACTURES:										
80	05	10		1057-1058					D	
80	05	14	16	3	42	50.20	-2.120	-0.100	F	0.83
80	05	14	17	3	42	58.26	-2.050	0.036	E	0.70
80	05	14	18	3	48	55.67	-1.390	0.882	E	1.09
80	05	16	19	8	1	35.00			E	0.85
80	05	16	20	8	6	6.00			F	0.50
80	05	16	21	8	8	18.00			F	0.62
80	05	16	22	8	14	2.00			H	1.13
80	05	16	23	8	19	13.34	-0.914	-4.722	I	1.25
80	05	16	24	8	24	7.00			I	1.07
80	05	16	25	8	28	14.00			I	1.13
80	05	16	26	8	30	12.31	-3.531	2.751	E	1.56
80	05	16	27	8	30	30.00			E	1.49
80	05	16	28	8	32	45.00			C	1.45
80	05	16	29	8	34	35.00			C	1.24
80	05	16	30	8	36	21.00			C	1.15
80	05	16	31	8	37	27.45	9.130	2.040	A	1.87
80	05	16	32	8	39	51.00			F	0.50
80	05	16	33	8	41	20.00			E	1.22
80	05	16	34	8	46	40.00			DE	1.06
80	05	16	35	8	49	0.00			F	1.36
80	05	16	36	8	50	32.00			E	1.24
80	05	16	37	8	55	32.00			F	1.24
80	05	16	38	9	3	49.06	-0.261	-1.173	I	1.08

Table 8 (continued)

DATE			EVENT NO.	TIME			COORDINATES		REGION	MAGNITUDE (MS)
YR	MO	DAY		HR	MIN	SEC	Y(KM)	X(KM)		
80	05	16	39	9	7	53.00			H	1.68
80	05	16	40	9	8	19.00			E	1.46
80	05	16	41	9	8	46.00			F	1.56
80	05	16	42	9	9	36.00			F	1.64
80	05	16	43	9	9	49.00			E	1.13
80	05	16	44	9	10	10.91	-2.960	4.078	D	1.68
80	05	16	45	9	11	54.00			A	2.03
80	05	16	46	9	12	37.00			C	1.61
80	05	16	47	9	12	46.00			D	1.22
80	05	16	48	9	13	13.00			A	1.65
80	05	16	49	9	13	44.00			B	1.67
80	05	16	50	9	14	52.00			A	1.65
80	05	16	51	9	15	38.00			A	1.65
80	05	16	52	9	17	24.00			B	1.53
80	05	16	53	9	19	42.00			A	1.76
80	05	21	54	9	7	0.00			D	0.98
80	05	21	55	9	13	0.00			J	1.43
80	05	21	56	9	30	0.00			J	1.10
80	05	21	57	9	33	10.00			I	1.21
80	05	21	58	9	33	50.00			A	1.49
80	05	21	59	9	34	30.00			I	1.13
80	05	21	60	9	36	50.00			I	1.21
80	05	21	61	9	41	0.00			H	1.27
80	05	21	62	9	42	50.00			I	1.43
80	05	21	63	9	43	0.00			E	1.24
80	05	21	64	9	44	0.00			E	1.32
80	05	21	65	9	45	0.00			A	1.90
80	05	21	66	9	45	10.00			A	1.49
80	05	21	67	9	48	30.00			D	1.08
80	05	21	68	9	50	20.00			B	1.63
80	05	21	69	9	51	10.00			G	1.58
80	05	21	70	9	52	20.00			D	1.42
80	05	21	71	9	53	0.00			B	1.41
80	05	21	72	9	55	0.00			C	1.19
80	05	21	73	9	55	50.00			C	1.27
80	05	21	74	9	58	0.00			C	1.27
80	05	21	75	9	59	0.00			B	1.41
80	05	21	76	10	0	0.00			B	1.71
80	05	21	77	10	1	10.00			B	1.47
80	05	21	78	10	2	0.00			G	1.27
80	05	21	79	10	2	30.00			I	1.27
80	05	21	80	10	3	30.00			B	1.41
80	05	21	81	10	3	50.00			B	1.47
80	05	21	82	10	5	0.00			C	1.19
80	05	21	83	10	6	0.00			C	1.39

Table 8 (continued)

DATE			EVENT NO.	TIME			COORDINATES		REGION	MAGNITUDE (MS)
YR	MO	DAY		HR	MIN	SEC	Y(KM)	X(KM)		
80	05	21	84	10	6	40.00			E	0.98
80	05	21	85	10	9	20.00			C	1.60
80	05	21	86	10	9	50.00			C	1.34
80	05	21	87	10	10	30.00			C	1.39
80	05	21	88	10	11	40.00			C	1.39
80	05	21	89	10	16	30.00			D	1.12
80	05	21	90	10	19	40.00			C	1.19
80	05	21	91	10	20	30.00			C	1.00
80	05	21	92	10	21	10.00			C	1.19
80	05	21	93	10	22	20.00			C	1.19
80	05	21	94	10	23	0.00			C	1.19
80	05	21	95	10	25	40.00			C	1.34
80	05	21	96	10	28	0.00			C	1.19
80	05	21	97	12	21	49.00			G	1.43
80	05	21	98	12	23	1.00			G	1.27
80	05	21	99	12	33	24.00			D	1.24
80	05	21	100	12	40	10.00			C	1.59
80	05	21	101	13	9	46.00			D	1.22
80	05	21	102	13	38	6.00			G	1.03
80	05	21	103	13	41	13.00			E	0.89

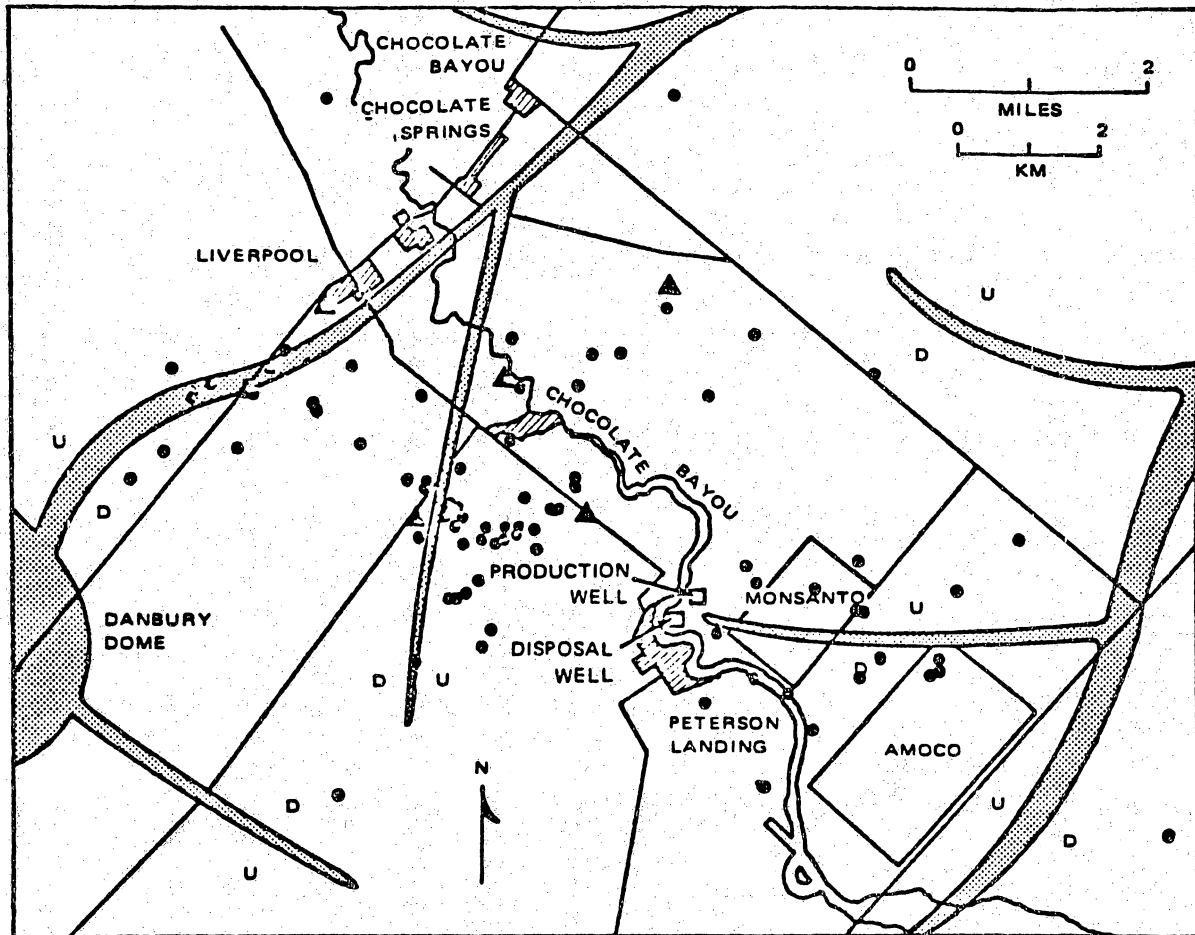

▲ STATIONS
 ● NATURAL EVENTS
 * HIGH-RATE SEQUENCE
 ■ PUMP NOISE

Figure 17. Cumulative epicenter map for natural events as of May 30, 1980.

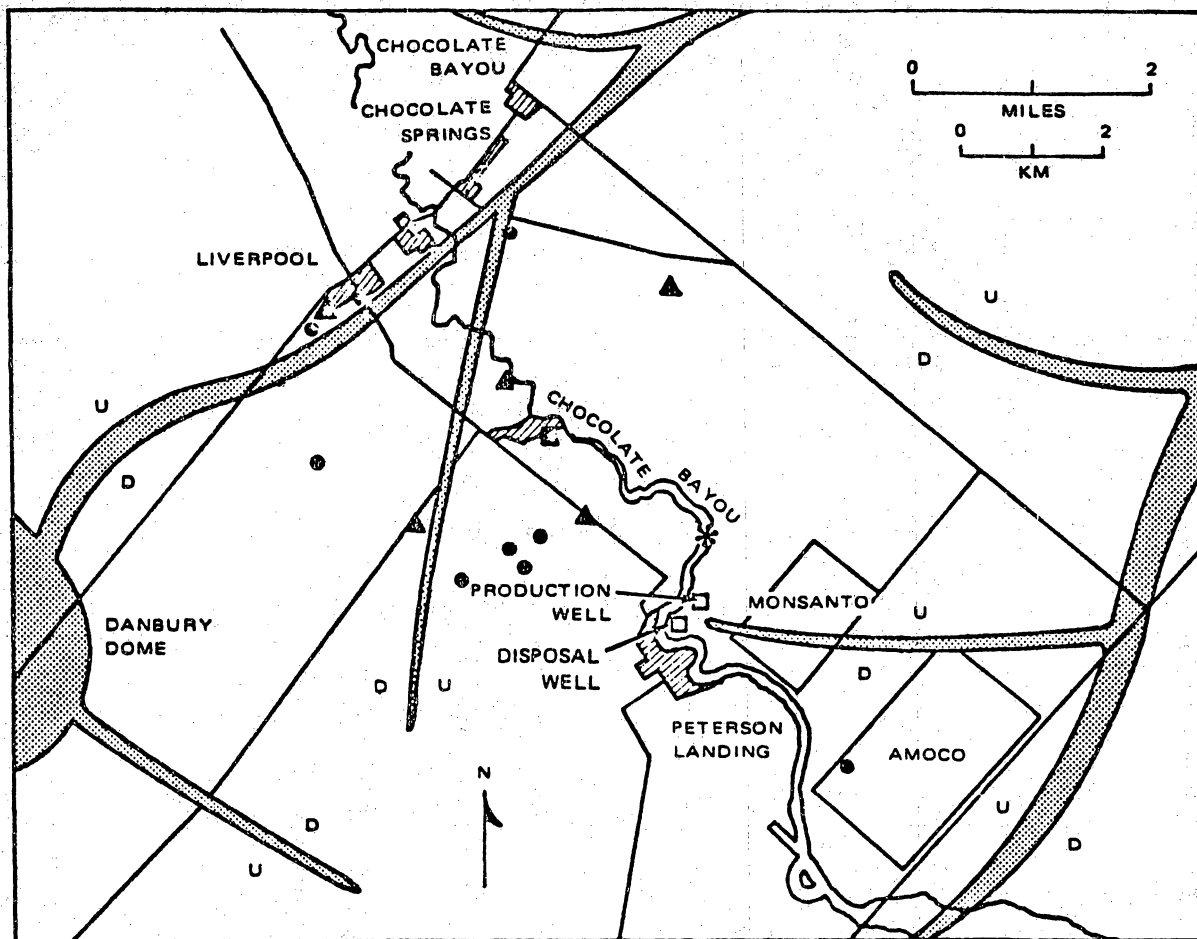

Figure 18. Epicenter map for June 1980.

Table 9. Microseismic events, June 1980.

DATE			EVENT NO.	TIME			COORDINATES		REGION	MAGNITUDE (MS)
YR	MO	DAY		HR	MIN	SEC	Y(KM)	X(KM)		
80	06	02	1	7	0	25.00			B	0.82
80	06	02	2	8	21	25.00			B	0.82
80	06	09	3	16	6	6.00			H	0.91
80	06	09	4	16	16	32.00			G	0.83
80	06	09	5	16	25	52.44	-2.689	-0.677	G	1.69
80	06	09	6	16	28	19.19	0.766	-2.622	I	1.52
80	06	09	7	16	31	10.00			K	0.98
80	06	09	8	16	31	32.00			K	0.98
80	06	09	9	16	32	2.44	2.005	0.077	A	1.30
80	06	09	10	16	39	52.00			A	1.30
80	06	09	11	16	40	50.00			E	0.86
80	06	09	12	16	42	31.00			E	0.96
80	06	09	13	16	56	53.23	-13.927	13.453	D	2.44
80	06	09	14	17	11	30.00			B	1.00
80	06	09	15	17	11	51.00			B	1.00
80	06	10	16	15	39	38.55	-5.347	4.456	E	1.62
80	06	12	17	6	55	1.35	-2.265	2.842	D	1.10
80	06	12	18	6	55	17.21	-2.001	2.626	D	1.20
80	06	19	19	1	29	0.00			C	1.24
80	06	21	20	22	23	54.00				
80	06	21	21	22	26	18.58	-2.095	0.372	E	1.24
80	06	21	22	22	26	26.65	-2.296	-0.029	F	1.10
80	06	21	23	22	26	29.60	-2.529	0.133	E	1.18
80	06	21	24	23	17	33.76	-1.016	-2.611	H	1.16
80	06	21	25	23	22	44.00			G	1.19
80	06	23	26	18	20	12.00			F	0.88

The natural events are thought to lie on or near growth faults which are mapped at a depth of 15,000 feet in figure 18. Consistent with previous activity the most active areas are at the southern edge of the array and just south of Liverpool. The June rate of 24 events per month is a decrease from the peak level of 103 events in May.

July

Activity during July is summarized in Table 10 and plotted in figure 19. Only one event clearly fits the established criteria for a natural event. In addition, two high rate sequences of seven events each occurred on the 9th and 30th. The first sequence located near Monsanto. During the other sequence only sites 1 and 5 were functional so any epicentral region from C through H is possible.

Figure 20 is a daily histogram of all activity classified as hydraulic fracturing or natural. The black columns represent high rate sequences located near the injection wells while the red columns represent all other acoustic or surface wave signals.

August

Activity during August is summarized in table 11 and located epicenters are plotted in figure 21. The majority of the events occurred in four high rate sequences in the vicinity of the petrochemical plants, apparently due to fluid injection. They are denoted by HF in table 11.

A different source of signals was recognized during the past month. Four events on August 7 had sharp spikes in the record preceding the signal. The spikes are interpreted as electrical interference due to lightning and the

Table 10. Microseismic events, July 1980.

DATE			EVENT NO.	TIME			COORDINATES		RFGION	MAGNITUDE (MS)
YR	MO	DAY		HR	MIN	SEC	Y(KM)	X(KM)		
80	07	03	1	13	2	44.12	6.061	1.819	A	1.93
80	07	09	2	7	50	11.13	-1.582	1.283	D	1.07
80	07	09	3	7	52	0.07	-1.963	2.582	D	1.14
80	07	09	4	7	53	52.80	-2.037	2.656	D	1.14
80	07	09	5	7	56	14.45	-2.263	2.835	D	0.96
80	07	09	6	8	7	1.08	-2.134	2.772	D	1.17
80	07	09	7	10	7	49.00			D	0.95
80	07	09	8	17	5	25.00			C	1.21
80	07	30	9	10	58	26.00			CH	1.00
80	07	30	10	10	58	56.00			CH	1.00
80	07	30	11	10	59	34.00			CH	1.00
80	07	30	12	11	0	34.00			CH	1.00
80	07	30	13	11	1	18.00			CH	1.00
80	07	30	14	11	1	36.00			CH	1.00
80	07	30	15	11	2	2.00			CH	1.00

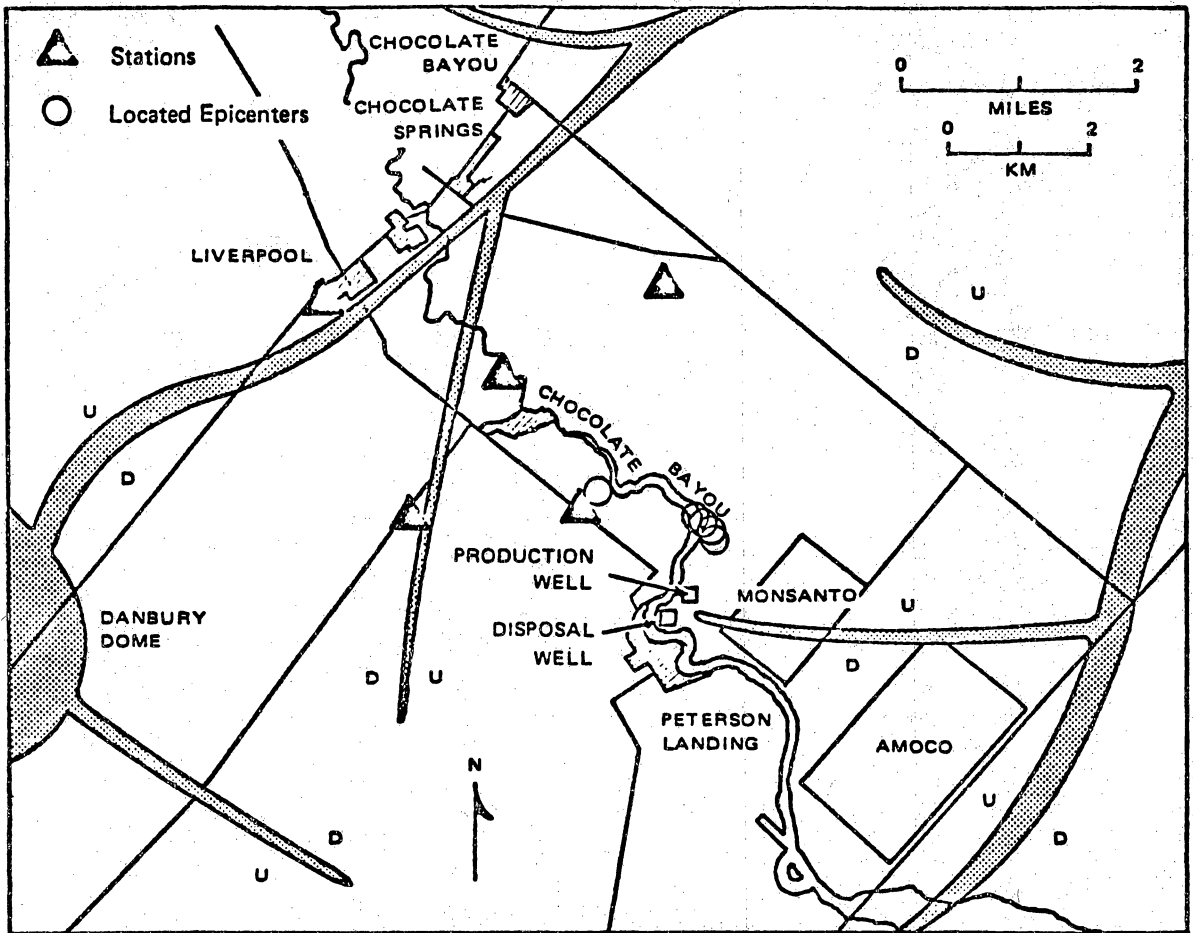

Figure 19. Epicenter map for July 1980.

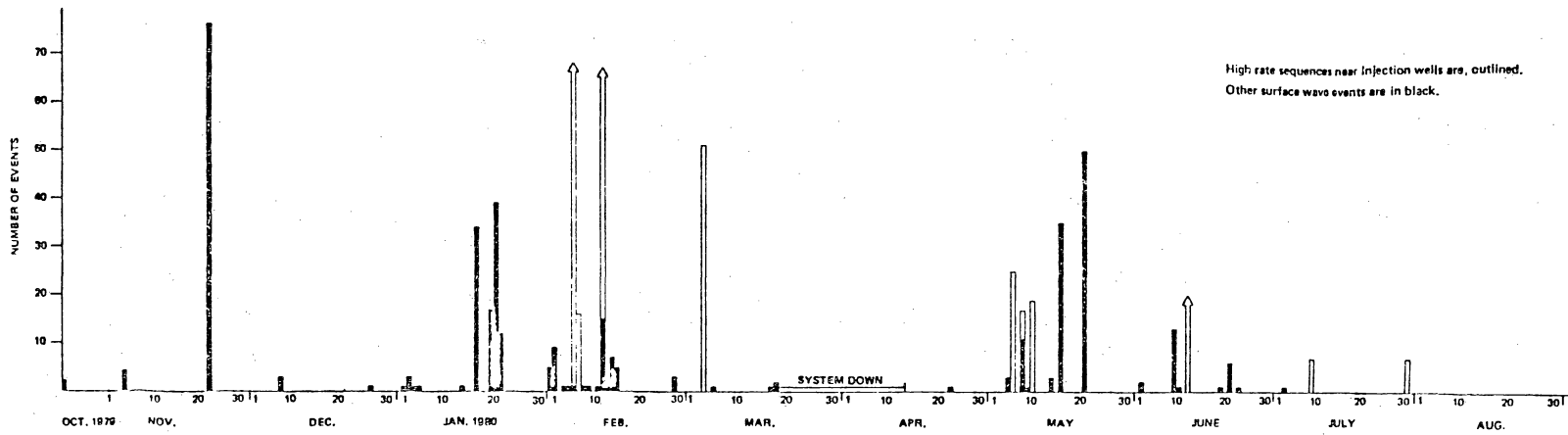

Figure 20. Daily histogram of all activity classified as hydraulic fracturing or natural.

Table 11. Microseismic events, August 1980.

DATE			EVENT NO.	TIME			COORDINATES		TYPE	MAGNITUDE (MS)
YR	MO	DAY		HR	MIN	SEC	Y(KM)	X(KM)		
80	08	07	1	15	57	0.47	0.583	2.236	L	1.58
80	08	07	2	15	59	47.00			L	1.28
80	08	07	3	16	11	33.00			L	0.83
80	08	07	4	16	11	49.00			L	0.83
80	08	08	5	6	29	11.00			HF	1.50
80	08	08	6	7	24	49.12	-2.406	2.816	HF	1.68
80	08	08	7	7	24	54.02	-2.347	2.778	HF	1.67
80	08	08	8	7	25	11.00			HF	1.20
80	08	08	9	7	25	14.00			HF	1.24
80	08	08	10	7	25	21.00			HF	1.54
80	08	08	11	7	25	28.00			HF	1.40
80	08	08	12	7	25	30.00			HF	1.45
80	08	08	13	22	33	43.61	-2.317	2.474	HF	1.37
80	08	08	14	22	32	55.98	-2.400	2.682	HF	1.61
80	08	08	15	22	37	7.31	-2.290	2.622	HF	1.47
80	08	08	16	22	42	12.00			HF	1.47
80	08	08	17	22	43	20.00			HF	1.45
80	08	08	18	22	51	50.00			HF	1.66
80	08	12	19	8	8	14.39	-2.890	3.983	HF	1.32
80	08	12	20	8	27	45.81	-2.925	4.206	HF	1.25
104 EVENTS:										
80	08	14		0320-1038			-4.158	3.694	HF	1.10-1.56
80	08	15	20	5	50	42.16	-3.522	3.126	HF	1.74
80	08	15	21	19	5	20.34	-2.214	1.959	HF	1.32
80	08	16	22	18	53	42.82	0.230	3.252	N	1.31
80	08	16	23	18	54	5.34	-0.528	3.640	N	1.74
21 EVENTS:										
80	08	17		0413-0429			-2.480	3.359	HF	1.45-1.62
95 EVENTS:										
80	08	18		0917-1056			-3.812	5.385	HF	1.30-1.52
13 EVENTS:										
80	08	23		1504-1518			-3.283	2.890	HF	1.18-1.42
80	08	24	24	3	57	27.88	0.154	0.383	N	1.30
80	08	25	25	1	3	0.00			N	1.25
80	08	25	26	19	31	22.52	0.022	0.472	N	1.19
80	08	26	27	0	55	24.44	-5.604	6.117	N	2.39
80	08	26	28	14	26	30.00			N	1.30
80	08	26	29	17	42	40.00			N	1.33
80	08	27	30	0	44	1.00			N	1.01
80	08	27	31	9	33	52.83	0.068	0.413	N	0.97
80	08	27	32	12	40	45.00			N	1.06
80	08	29	33	17	38	12.45	0.190	0.317	N	1.26
80	08	29	34	18	56	20.00			N	0.97
80	08	29	35	21	47	20.00			N	1.00

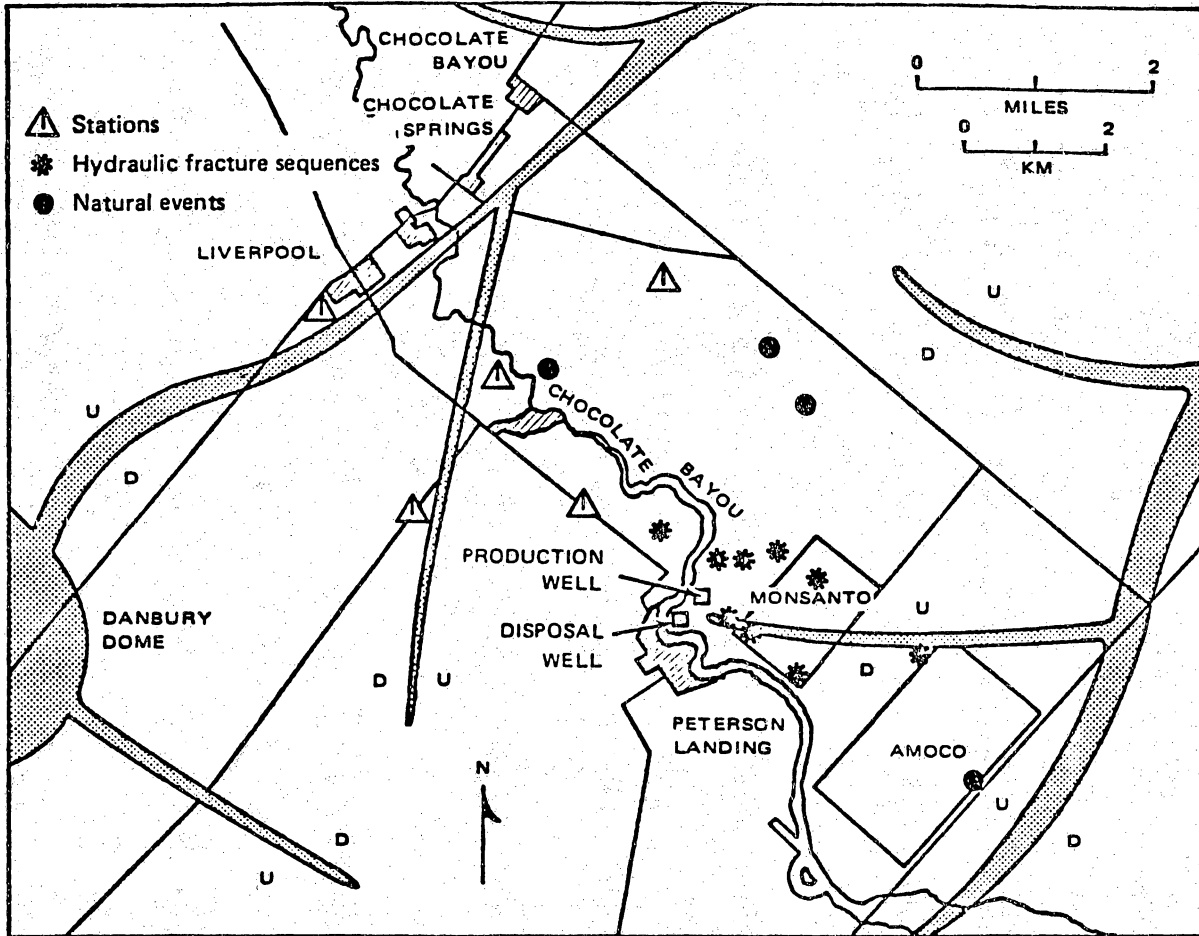

Figure 21. Epicenter map for August 1980.

acoustic velocity signal which follows is thunder. This is an unusual recording and the first of its kind to be noticed in the Brazoria County records.

Fourteen events of the natural type were also seen late in the month. They are located within a few kilometers of the injection wells and may also be related to injection, though less directly than the sequences discussed above. The fault running south through the array has been the most active in the past and seems to be the most active again.

It is possible that many of the events previously described as natural are, in fact, due to thunder. Since spike-like pulses are usually ignored in a seismic record, the preceding lightning flashes may have gone unnoticed or may have been too small to detect. On the other hand, the spatial distribution does imply involvement of growth faults and injection wells as sources of some of the events. Daily weather records could resolve some of this ambiguity.

September

Seismic activity observed during September is summarized in table 12. Those events classified as probable type "L" have acoustic velocities and spikes in the preceding record which are presumed to be due to lightning. These occurred on the 7th and 24th. Thunder was heard at Houston Intercontinental Airport on the 6th, 7th and 8th and a trace of rain fell on the 24th.

Type N events are similar but do not have visible lightning spikes. Since these occur on the 6th, 7th and 24th they may be due to thunderstorms also, or they could be growth fault movements. Epicenter locations for activity on the 24th are given in figure 22.

Only the 204 events on September 16 corresponded with clear weather. Although these could not be located, similar sequences in the past have had

Table 12. Microseismic events, September 1980.

DATE			EVENT NO.	TIME			COORDINATES		PROBABLE TYPE	MAGNITUDE (MS)	
YR	MO	DAY		HR	MIN	SEC	Y(KM)	X(KM)			
80	09	06	1	12	22	8.00			N		
80	09	06	2	12	24	38.00			N		
80	09	06	3	12	25	30.			N		
80	09	06	4	12	26	20.			N		
80	09	06	5	12	28	32.00			N		
80	09	06	6	12	29	24.00			N		
80	09	06	7	12	34	30.00			N		
80	09	06	8	14	30	54.00			N		
80	09	07	9	4	16	23.00			N		
80	09	07	10	4	19	30.00			L		
80	09	07	11	4	21	0.			L		
80	09	07	12	15	25	16.00			N		
80	09	07	13	18	24	14.00			N		
80	09	07	14	18	24	26.00			N		
80	09	16	15	1	37	0.			HF		
80	09	16	16	1	47	0.			HF		
202 EVENTS:											
80	09	16		0330-0700						HF	
80	09	24	17	7	12	8.79	-1.802	0.870	N	1.17	
80	09	24	18	8	54	34.22	3.034	-1.605	N	1.37	
80	09	24	19	9	27	1.99	-2.508	3.053	N	1.47	
80	09	24	20	9	27	12.38	-1.742	0.914	N	1.24	
80	09	24	21	9	29	6.47	-1.621	1.428	N	1.34	
80	09	24	22	9	32	50.45	-1.900	0.872	N	1.17	
80	09	24	23	9	34	21.66	-1.811	0.900	N	1.14	
80	09	24	24	9	34	25.40	-1.091	1.638	N	1.41	
80	09	24	25	9	34	43.48	-1.764	0.898	N	1.18	
80	09	24	26	16	22	30.			L		

N = NATURAL
L = LIGHTNING
HF = HYDRAULIC FRACTURE

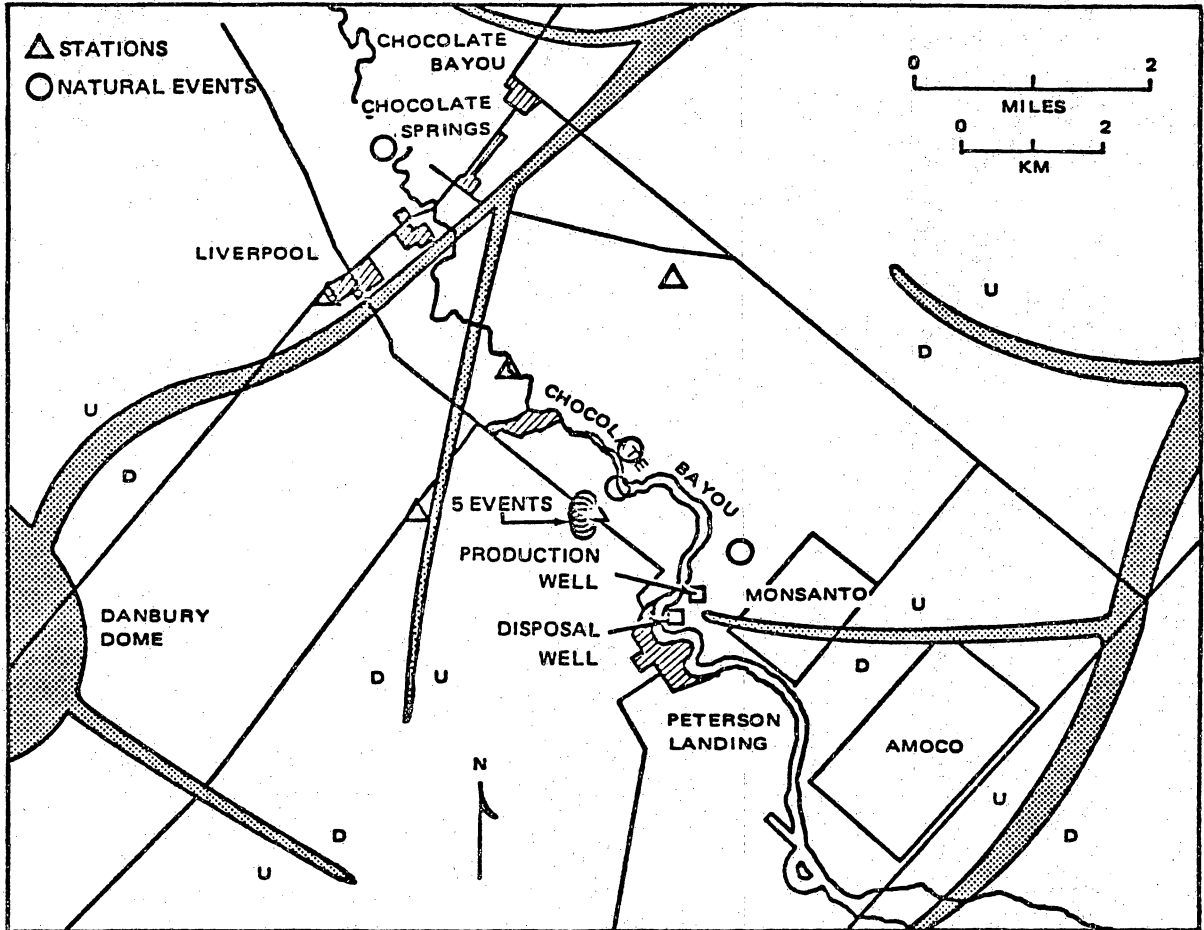

Figure 22. Epicenter map for September 1980.

sources very near the Monsanto plant, presumably associated with fluid injection.

It should be noted that production at the DOE well did not commence until 1500 GMT on the 16th, eight hours after the seismic sequence had ended.

There were also 101 seismic shots during the month, all of which occurred during the daylight hours.

October

Microseismic activity in October was dominated by signals from the petrochemical plants from October 17-24, including 302 signals on the 22nd. Epicenters are plotted as asterisks in figure 23. This activity was absent on weekends, further evidence of cultural origins.

Natural events without lightning flashes were observed on the 17th, 18th, 22nd, 26th and 27th, local time. Those which could be located were restricted to two regions which have long demonstrated similar activity (figure 23). Three events with apparent lightning flashes were also located and plotted in figure 23 as open circles. They were scattered across the array. Unfortunately, the natural events which were concurrent with thunder on the 27th could not be located.

The sources of the natural events are still uncertain.

Table 13. Microseismic events, October 1980.

DATE			EVENT NO.	TIME			COORDINATES		TYPE	MAGNITUDE (MS)
YR	MO	DAY		HR	MIN	SEC	Y(KM)	X(KM)		
80	10	17	1	10	20	50.00			HF	
80	10	17	2	10	21	0.28	-1.567	2.720	HF	1.18
80	10	17	3	10	21	11.15	-1.518	2.695	HF	1.00
80	10	17	4	10	21	25.72	-1.526	2.710	HF	1.17
80	10	17	5	10	21	42.96	-1.604	2.778	HF	1.19
80	10	17	6	10	21	55.89	-1.502	2.644	HF	1.16
80	10	17	7	14	19	3.00			HF	
80	10	17	8	14	19	12.00			HF	
80	10	17	9	22	13	57.77	-0.088	-3.078	N	1.26
80	10	18	10	23	50	54.00			N	
80	10	18	11	23	56	31.00			N	
80	10	19	12	0	2	52.00			N	
80	10	19	13	0	5	17.22	-1.581	-1.019	N	1.26
80	10	19	14	0	6	34.93	-1.553	-0.298	N	1.08
80	10	19	15	0	11	1.00			N	
80	10	19	16	0	34	51.41	-0.617	-4.316	N	1.32
80	10	19	17	0	39	55.06	-1.408	0.829	N	0.99
80	10	19	18	0	42	3.00			N	
80	10	19	19	1	40	33.00			N	
80	10	19	20	1	45	41.87	-0.511	-0.053	N	0.75
80	10	20	21	5	19	46.88	-1.928	3.061	HF	1.13
80	10	20	22	6	30	57.20	-1.944	3.104	HF	1.11
80	10	21	23	7	47	50.00			HF	
25 EVENTS:										
80	10	21	24	7	52	39.41	-4.159	5.746	HF	1.14
18 EVENTS:										
80	10	21	25	8	13	51.20	-5.205	7.043	HF	1.65
86 EVENTS:										
80	10	22	26	0	46	5.07	-4.063	5.536	HF	1.35
80	10	22	27	0	48	34.57	-3.607	4.979	HF	1.34
80	10	22	28	0	54	23.50	-4.507	6.388	HF	1.67
22 EVENTS:										
80	10	22	29	16	19	28.27	0.584	-4.532	HF	1.41
80	10	22	30	16	19	42.00			N	
80	10	22	31	20	27	20.00			HF	
8 EVENTS:										
80	10	22	32	23	28	49.66	-2.082	2.645	HF	1.23
185 EVENTS:										
80	10	22	33	23	43	13.77	-2.591	3.133	HF	1.64
80	10	23	34	3	32	1.00			HF	
22 EVENTS:										
80	10	23	36	6	54	45.00			HF	
22 EVENTS:										
80	10	24	37	11	3	32.98	-3.005	3.487	HF	1.39

Table 13 (continued)

DATE YR MO DAY	EVENT NO.	TIME			COORDINATES		TYPE	MAGNITUDE (MS)
		HR	MIN.	SEC.	Y(KM)	X(KM)		
80 10 25	38	10	51	56.81	-1.851	2.939	HF	1.70
80 10 26	39	2	50	44.00			N	
80 10 26	40	2	52	36.00			N	
80 10 26	41	2	53	45.00			N	
80 10 27	42	20	10	9.00			N	
80 10 27	43	20	11	0.00			N	
80 10 27	44	20	12	44.50	-4.543	3.084	L	1.85
80 10 27	45	20	15	0.00			N	
80 10 27	46	20	24	10.36	4.067	-0.869	L	1.43
80 10 27	47	20	36	20.16	1.032	1.802	L	1.25
80 10 27	48	20	38	0.00			N	
80 10 28	49	1	57	0.00			N	
80 10 28	50	5	0	0.00			R	

HF = HIGH RATE CHEMICAL PLANT SEQUENCE
 N = NATURAL EVENT, NO FLASH
 L = ACOUSTIC SIGNAL WITH LIGHTNING FLASH
 R = REGIONAL EVENT

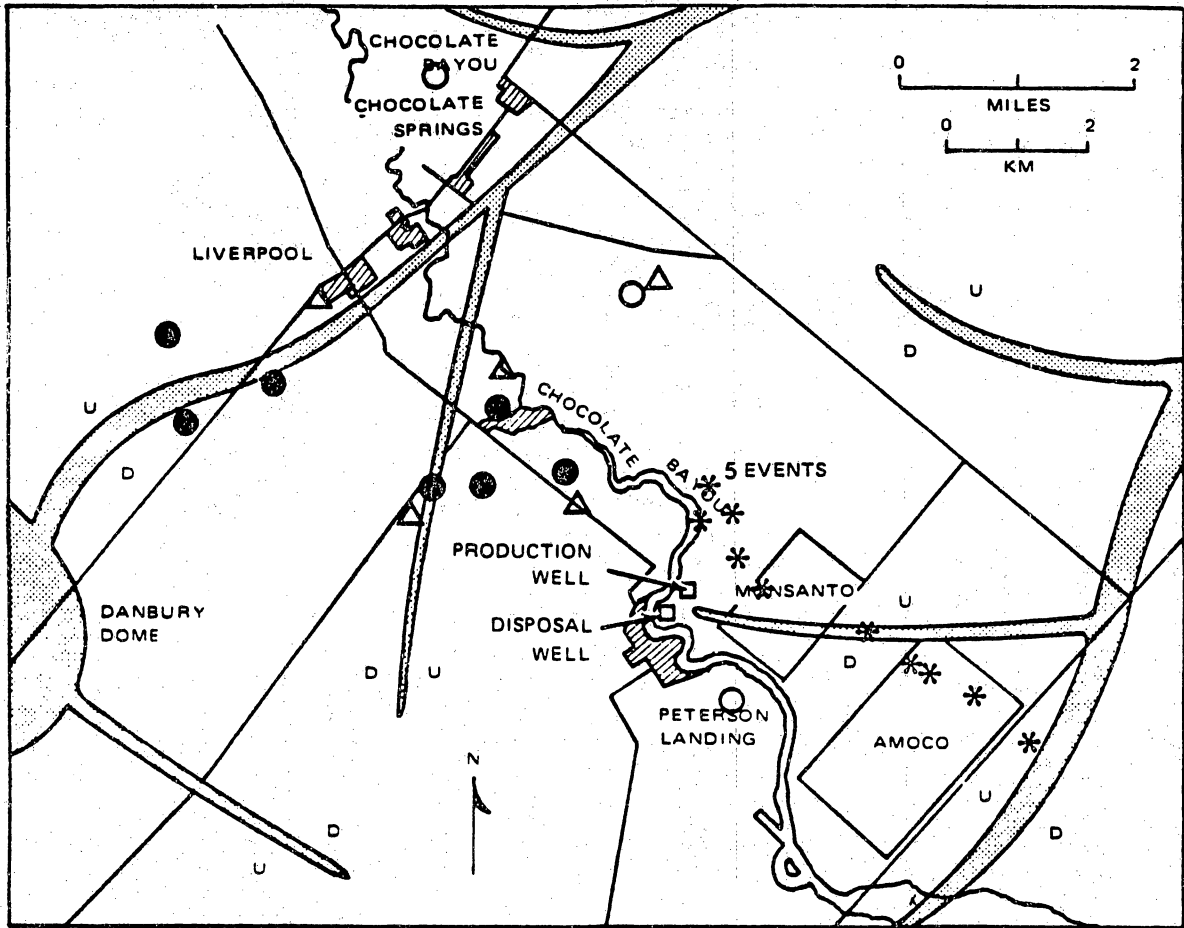

- △ STATIONS
- * HIGH RATE SEQUENCES
- NATURAL EVENTS WITHOUT FLASH
- ACOUSTIC EVENT WITH PRECEDING FLASH

Figure 23. Epicenter map for October 1980.

REFERENCES

Bebout, D. G., Loucks, R. G., and Gregory, A. R., 1978, Frio sandstone reservoirs in the deep subsurface along the Texas Gulf Coast--their potential for the production of geopressured-geothermal energy: The University of Texas, Austin, Bureau of Economic Geology, Rpt. Inv. 91, 93 p.

Geertsma, J., Land subsidence above compacting oil and gas reservoirs, Jour. Pet. Tech.; June 1973, p. 734-744, 1973.

Grimsrud, G. P., Turner, B. L., and Frame, P. A., (1978), Areas of Ground Subsidence due to Geofluid Withdrawal; Systems Control Report for Lawrence Berkeley Laboratory, Report No. LBL-8618, GSRMP-4, UC-66c, 61 p.

Johnson, J. L., Clawson, G. E., and Swanson, J. G., 1977, program MEHYPO with 1977 modifications: TN 3/77: Garland, Texas, Teledyne Geotech, 25 p.

Karnik, V., 1961, Seismicity of Europe, Progress Report II, International Union of Geodesy and Geophysics Monograph 9.

White, W. A., McGraw, M., and Gustavson, T. C., 1978, Environmental analysis of geopressured-geothermal prospect areas, Brazoria and Kenedy Counties, Texas, Austin, Texas, Bureau of Economic Geology, University of Texas, 203 p.