



Aalborg Universitet

AALBORG UNIVERSITY
DENMARK

A Method for Online Steady State Energy Minimization with Application to Refrigeration Systems

Larsen, Lars Finn Sloth; Thybo, Claus; Stoustrup, Jakob; Rasmussen, Henrik

Published in:
Proceedings on IEEE Conference on Decision and Control 2004

Publication date:
2004

Document Version
Publisher's PDF, also known as Version of record

[Link to publication from Aalborg University](#)

Citation for published version (APA):
Larsen, L. F. S., Thybo, C., Stoustrup, J., & Rasmussen, H. (2004). A Method for Online Steady State Energy Minimization with Application to Refrigeration Systems. In Proceedings on IEEE Conference on Decision and Control 2004 (Vol. 5, pp. 4708-4713)

General rights

Copyright and moral rights for the publications made accessible in the public portal are retained by the authors and/or other copyright owners and it is a condition of accessing publications that users recognise and abide by the legal requirements associated with these rights.

- ? Users may download and print one copy of any publication from the public portal for the purpose of private study or research.
- ? You may not further distribute the material or use it for any profit-making activity or commercial gain
- ? You may freely distribute the URL identifying the publication in the public portal ?

Take down policy

If you believe that this document breaches copyright please contact us at vbn@aub.aau.dk providing details, and we will remove access to the work immediately and investigate your claim.

A Method for Online Steady State Energy Minimization, with Application to Refrigeration Systems

Lars Finn Sloth Larsen, Claus Thybo, Jakob Stoustrup and Henrik Rasmussen

Abstract—Energy efficiency of refrigeration systems has gradually been improved with the help of control schemes utilizing the more flexible components; the efficiency is though yet far from optimal. The flexibility initiates a higher degree of freedom in choosing the operating set points while obtaining the required cooling capacity. This paper proposes an approach which utilizes this newly gained degree of freedom to drive the system towards the energy optimal set-point while keeping up the cooling capacity. The focus of this paper is on refrigeration system however the generality of the proposed method thus applies to a broader range of process systems where the lower level set-points (in the control hierarchy) can be chosen within a degree of freedom allowing an optimization of a steady state performance index.

I. NOMENCLATURE

c_w	Heat capacity water $\left[\frac{J}{kg \cdot K}\right]$
f_q	Heat loss coefficient compressor
h	Enthalpy $\left[\frac{J}{kg}\right]$
K_{cp}	Power constant condenser pump $\left[\frac{W \cdot s^3}{kg^3}\right]$
\dot{m}_{ref}	Mass flow refrigerant $\left[\frac{kg}{s}\right]$
\dot{m}_w	Mass flow water $\left[\frac{kg}{s}\right]$
N	Rotational speed [rpm]
OD	Opening Degree
P	Pressure [bar]
\dot{Q}_e	Cooling capacity [W]
SH	Superheat [K]
SC	Subcooling [K]
T	Temperature [K]
UA	Heat transfer coefficient $\left[\frac{kJ}{s \cdot K}\right]$
\dot{W}	Power consumption [W]
η	Efficiency

Indices

C	Compressor
CP	Condenser pump
EP	Evaporator pump
c	Condenser
e	Evaporator

is	Isentropic
ie	Inlet evaporator
oe	Outlet evaporator
ic	Inlet condenser
oc	Outlet condenser
wic	Water inlet condenser
woc	Water outlet condenser
wie	Water inlet evaporator

II. INTRODUCTION

Many process systems operate for long periods in a steady state mode, that is the control objective is more or less just disturbance rejection. Furthermore they often have the characteristic that the lower level set-points can be chosen within some degree of freedom while still obtaining the objective of the given process. Systems with this specific enables the possibility for set-point optimization, where the performance function to be optimized could be various things such as production costs, energy consumption and so forth. Many controllers for larger process systems has thus in the top-layer implemented various kinds of advanced optimization tools for predicting optimal set-points, for instance in power plant controllers (Mølbak, 2003). For cheaper and mass-produced plants such as refrigeration systems, it is not realistic to make such an effort in each controller, but the need for an intelligent way to choose the set-points is thus still present. The requirement to an optimization tool for these systems differs in the way that it should be less complex and apply more generally to various composition of the same class of system, being for instance refrigeration systems.

The approach in this paper is to use the information in the cost function gradient and a prediction of the steady state to drive the a system to a less energy consuming steady state operation. In the case of a convex energy-cost function, even to the overall optimum. The proposed method is exemplified by applying it to a refrigeration system in order to minimize of the power consumption.

III. INDIRECT METHOD FOR ON-LINE STEADY STATE OPTIMIZATION

Indirect methods or model based methods use a model for the search of the steady state optimum. Since no models in practice describes the process exact the hereby found optimum will be an estimate of the real optimum. This mismatch can be caused by several factors as pointed out by (Svensson, 1994):

- errors in the model structure

L.F.S. Larsen and C. Thybo is with Central R&D - Refrigeration and Air Conditioning, Danfoss A/S, Nordborg, Denmark. lars.larsen@danfoss.com, thybo@danfoss.com

J. Stoustrup and H. Rasmussen is with the Department of Control Engineering, Aalborg University, Aalborg, Denmark jakob@control.aau.dk, hr@control.aau.dk

- uncertain parameters
- unmeasured disturbances influencing the process
- unknown state variables
- measurement noise

In the following it is assumed that all important disturbances (\mathbf{v}) and state variables (\mathbf{x}) are available either measured or estimated, that is they are at least observable. The here proposed method can be divided into three layers namely a steady state optimization, a steady state prediction and a model parameter adaption.

The optimization layer tries to minimize the steady state performance function here given as the power consumption (\dot{W}) in the system:

$$\min_{\mathbf{u}_{ss}} \dot{W}(\mathbf{x}_{ss}, \mathbf{u}_{ss}, \mathbf{v}_{ss}), \quad (1)$$

where \mathbf{x}_{ss} is a vector containing the relevant states, \mathbf{u}_{ss} is the control signal and \mathbf{v}_{ss} is the disturbance to the system; the index ss denotes steady state. Assuming that the states (x) are (controllable) controlled by a series of distributed controllers, the optimization can be performed just by manipulating the states instead of the control signals, that is:

$$\min_{\mathbf{x}_{ss}} \dot{W}(\mathbf{x}_{ss}, \mathbf{u}_{ss}(\mathbf{x}_{ss}, \mathbf{v}_{ss}), \mathbf{v}_{ss}), \quad (2)$$

where the control signal is generated by output feedback ($u = u(x)$). Hereby the optimal set-points can be calculated and passed on as reference to the distributed controllers. This however calls for some computation even in the unconstrained convex case, where the optimum is found at:

$$\left. \frac{d\dot{W}(\mathbf{x}_{ss}, \mathbf{u}_{ss}(\mathbf{x}_{ss}, \mathbf{v}_{ss}), \mathbf{v}_{ss})}{d\mathbf{x}_{ss}} \right|_{\mathbf{v}_{ss}=\text{const.}} = \mathbf{0}, \quad (3)$$

assuming \mathbf{v}_{ss} is constant and $x = x(u, v)$. However instead of implementing an algorithm that calculates the optimal set-point (\mathbf{x}_{ss}^*) directly, the cost function derivative ($\frac{d\dot{W}}{d\mathbf{x}_{ss}}$) can be used as a control error in a outer loop, as depicted in Figure 1, that is of course if the optimization problem is strictly convex or if the cost function declines globally towards the global optimum. If this is not the case, there is no guarantees that this method will converge to the global optimum, it could be stuck in a saddle point or a local minima. However if the optimization is started at a given steady state the steady state performance will at least not be deteriorated and in many cases it will be improved. This is because it always follows the course of the gradient, which points towards an evenly or less expensive place. Later it shall be shown, that for a refrigeration system the minimization of the energy consumption thus leads to a convex optimization problem, this is also assumed to be the case for energy-cost functions in many other applications.

Since a steady state cannot be measured continuously it has to be estimated. This is done by assuming that the present control signals (\mathbf{u}) and disturbances (\mathbf{v}) are constant until a steady state is reached, that is $\mathbf{u} = \mathbf{u}_{ss}$ and $\mathbf{v} = \mathbf{v}_{ss}$.

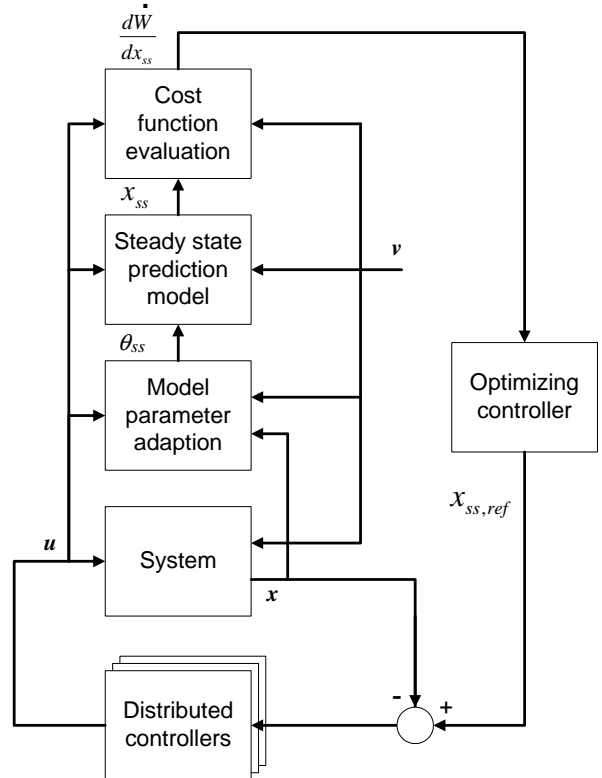

Fig. 1. The optimizing control structure using the gradient approach.

Hereby an estimate of \mathbf{x}_{ss} can be derived using a static model of the system as shown in Figure 1.

The last layer adapts the model parameters (θ) fitting the real system. In this layer the dynamic of the system has to be considered; otherwise the parameter adaption will be inaccurate in the transients. However the only purpose of the included dynamic in this layer is to filter out the dynamic behavior from the system in the parameter estimates. Therefore the parameters which concerns the dynamic are not really of interest. These parameters are therefore left out of the adaption and rough guesses used instead. A setup like this will be sufficient for estimating steady state slowly/not varying parameters (θ_{ss}).

The proposed method gives a simple approach to implementing an energy optimizing control, without a complex solver and only calls for little work in deriving a fairly simple and general static model.

IV. ENERGY OPTIMIZING CONTROL

The potential savings using optimal set points for the evaporator and the condenser pressure in the control of refrigeration systems has been shown to be substantial. Examples of that are given in (Jakobsen *et al.*, 2001) and (Larsen and Thybo, 2004).

The goal of an energy optimization is to keep the cooling capacity (\dot{Q}_e) constant while lowering the overall power consumption to a minimum at steady state. For a 1:1 refrigeration system, like shown in Figure 2, can the minimization

be written as:

$$\begin{aligned} & \min_{[N_C, N_{EF}, N_{CF}, OD]} (\dot{W}_C + \dot{W}_{EF} + \dot{W}_{CF}), \\ & s.t. \\ & \dot{Q}_e = Const, SH = Const \end{aligned} \quad (4)$$

(the notations refers to Figure 2). Besides a constant cooling

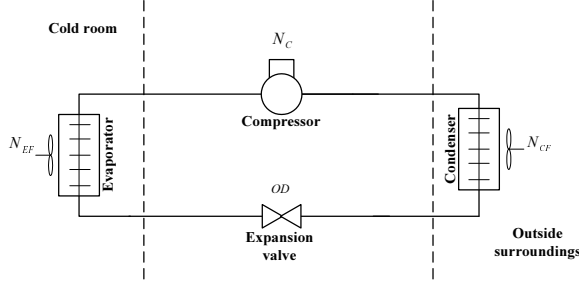

Fig. 2. System layout, a 1:1 refrigeration system, that is 1 compressor and 1 evaporator.

capacity, it is assumed, as indicated in Eq. 4, that a constant low superheat (SH) will ensure high efficiency of the evaporator. These constrains ($\dot{Q}_e = Const, SH = Const$) reduce the degree of freedom in the minimization till two, which means that the evaporator and the condenser pressure should be manipulated in order to find the minimal power consumption.

An important point that is stated in (Larsen and Thybo, 2004) and (Jakobsen *et al.*, 2001) is that the optimal condenser pressure is practically independent of the current evaporator pressure. This means that the evaporator and condenser pressure can be optimized individually as two 1 degree of freedom optimization problems in order to reach the global optimum (the maximal efficiency).

(Larsen *et al.*, 2003) proposes a method which optimizes the condenser pressure by solving *one* of the two 1 degree of freedom optimization problems. That is assuming a constant evaporator/suction pressure (P_e), controlled by an internal loop along with a constant constant cooling capacity (\dot{Q}_e) and superheat (SH). This results in following optimization in accordance to Eq. (4):

$$\begin{aligned} & \min_{[N_C, N_{EF}, N_{CF}, OD]} (\dot{W}_C + \dot{W}_{EF} + \dot{W}_{CF}), \\ & s.t. \\ & \dot{Q}_e = Const, SH = Const, P_e = Const \end{aligned} \quad (5)$$

Figure 3 shows the power consumption of the individual components in a 1:1 system (see Figure 4), for a constant evaporation pressure, superheat and cooling capacity. It can be seen that the energy-cost function here is strictly convex. Finding the optimal condenser pressure results in a equality constrained convex optimization problem. By inserting the equality constrains the optimization problem, one can rewrite it into an unconstrained one, where the

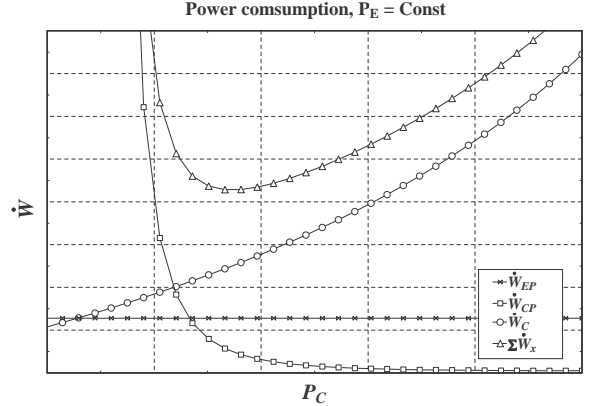

Fig. 3. Power consumption in the individual components ($\Sigma \dot{W}_x = \dot{W}_C + \dot{W}_{CF} + \dot{W}_{EF}$)

optimum is found at the condenser pressure that satisfies

$$\frac{\partial \dot{W}_C}{\partial P_C} \Big|_{\dot{Q}_e, P_e, SH=C} + \frac{\partial \dot{W}_{CF}}{\partial P_C} \Big|_{\dot{Q}_e, P_e, SH=C} = 0 \quad (6)$$

The evaporator pressure (P_e) and cooling capacity (\dot{Q}_e) are kept constant, thus $\frac{\partial \dot{W}_{EF}}{\partial P_C} = 0 \forall P_C$. By calculating the power gradient (Eq. 6) and driving it towards zero, controlling the condenser pressure, the optimum can be found, see Figure 4. The approach described in the previous chapter is used for this procedure.

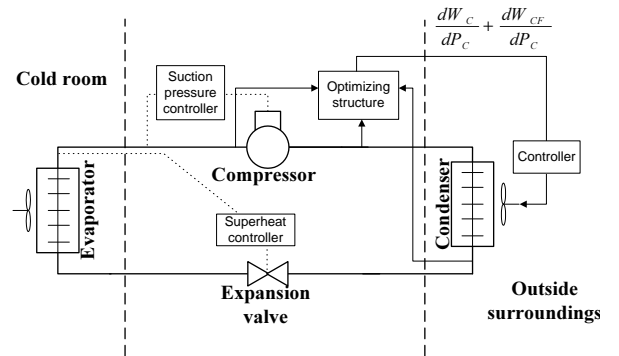

Fig. 4. The system layout, with the optimizing control structure.

V. STATIC MODEL

In order to be able to predict the steady state and estimate the power gradients, a model is needed as argued above. Since the potential energy savings can be obtained at steady state it is only required that Eq. (4) is fulfilled at steady state. The static model will be used for in the model parameter adaption as well thus extended with a first order filter to model some dynamic, however some of the dynamic behavior will be considered as disturbance to the model parameter estimates, this disturbance thus settles to zero

at steady state. Consequently this means that even if the dynamic is only roughly estimated the parameter estimates will be correct at steady state.

The model is based on a 1:1 system like depicted in Figure 2. Instead of fans blowing air across the evaporator and condenser, pumps circulate water through heat exchangers which makes up the evaporator and condenser in the system. The following 6 equations describes the steady state condition for the system.

$$\dot{W}_C = \frac{1}{1-f_q} \cdot \dot{m}_{ref}(h_{ic} - h_{oe}) \quad (7)$$

$$\dot{W}_{CP} = K_{CP} \cdot (\dot{m}_w)^3 \quad (8)$$

$$T_{woc} = T_c + (T_{wic} - T_c) \cdot \exp\left(-\frac{UA}{\dot{m}_w \cdot c_w}\right) \quad (9)$$

$$\dot{Q}_e = \dot{m}_{ref}(h_{oe} - h_{oc}) \quad (10)$$

$$0 = \dot{m}_{ref}(h_{ic} - h_{oc}) - \dot{m}_w c_w (T_{woc} - T_{wic}) \quad (11)$$

$$\eta_{is} = \frac{\dot{m}_{ref}(h_{is} - h_{oe})}{\dot{W}_C} \quad (12)$$

The abbreviations can be found in the nomenclature.

Equation (7) describes the power consumption in the compressor assuming a constant heat loss coefficient f_q .

Equation (8) describes the power consumption in the condenser pump.

Equation (9) can be derived assuming a lumped temperature of the wall between the refrigerant and the water and constant condensing temperature all through the condenser.

Equation (10) describes the cooling capacity of the evaporator.

Equation (11) describes the conservation of energy across the condenser wall.

Equation (12) describes the isentropic efficiency of the compressor.

In the equations above it is implied that the enthalpies (h) are functions of the respective pressures and temperatures. The equations are used as basis for the parameter and power gradient estimation.

VI. LAYERS IN THE OPTIMIZATION STRUCTURE

Before the optimization structure can be implemented on a refrigeration system the control input(\mathbf{u}), states (\mathbf{x}) and disturbances (\mathbf{v}) has to be identified. As described in chapter IV, we wanted to minimize the energy consumption while controlling the condenser pressure (P_c), therefore:

$$\mathbf{x} = [P_c]$$

The control input is the mass flow of water through condenser pump,

$$\mathbf{u} = [\dot{m}_w]$$

The remaining variables are considered as disturbances, that is:

$$\mathbf{v} = [\dot{W}_C, \dot{W}_{CP}, P_c, T_{ic}, T_{wic}, T_{woc}, m_{ref}, P_e]^T$$

these are all considered to be available; measured or estimated.

Cost Function evaluation

The cost function is here defined as the sum of the power consumption in the compressor and the condenser pump. Using Eq. (7), (8), (12) and inserting the equality constraint $\dot{Q}_e = \text{constant}$ given by Eq. (10) the cost function can be written as:

$$\dot{W}_C + \dot{W}_{CP} = \frac{1}{\eta_{is}} \cdot \dot{Q}_e \frac{h_{is} - h_{oe}}{h_{oe} - h_{oc}} + K_{CP} \cdot (\dot{m}_w)^3$$

When the steady state estimate on the condenser pressure ($x_{ss} = P_{c,ss}$) is passed from the steady state estimation layer can the cost function gradient be estimated by calculating the cost of $P_{c,ss}$ and $P_{c,ss} + \Delta P_{c,ss}$. In this case the gradient could of course be derived analytically but this is not always the case if more advanced models are used or if the model is based on table lookup.

Steady state prediction

In this case the state that is of interest is the condenser pressure P_c . From Eq. (7), (9), (10), (11) and (12) can the steady state $P_{c,ss}$ be found by iteration, assuming \dot{Q}_e , P_e and \dot{m}_w is kept constant.

Model Parameter Estimation

The parameter estimation is carried out by using the MIT rule (Åström and Wittenmark, 1989). Using this adaptive parameter adjustment routine, the parameters can be tuned by minimizing the error between the measurements and the model, that is in accordance to the following equation (Åström and Wittenmark, 1989) :

$$\frac{\partial \theta}{\partial t} = -\gamma e \frac{\partial e}{\partial \theta}, \quad (13)$$

where e denotes the model error and θ the parameter estimate. The parameter γ determines the adaption rate. Rewriting (7)-(12) following parameter dependent error can be obtained:

$$e(\theta) = \begin{bmatrix} \frac{h_{ic} - h_{oe}}{\dot{W}_C} - \frac{1 - \hat{f}_q}{\hat{m}_{ref}} \\ \frac{\dot{W}_{CP}}{(\dot{m}_w)^3} - \hat{K}_{CP} \\ \dot{m}_w c_w \ln\left(\frac{T_c - T_{wic}}{T_c - T_{woc}}\right) - \hat{UA} \\ h_{oe} - h_{oc} - \frac{\hat{Q}_e}{\hat{m}_{ref}} \\ \frac{h_{is} - h_{oe}}{\dot{W}_C} - \frac{\hat{\eta}_{is}}{\hat{m}_{ref}} \end{bmatrix}, \quad (14)$$

where $\theta = [\hat{f}_q, \hat{K}_{CP}, \hat{UA}, \hat{Q}_e, \hat{\eta}_{is}]^T$, the remaining variables and constants are assumed to be either known or measured.

From (14) the derivative can be derived:

$$\frac{\partial e}{\partial \theta} = \begin{bmatrix} \frac{1}{\hat{m}_{ref}} & 0 & 0 & 0 & 0 \\ 0 & -1 & 0 & 0 & 0 \\ 0 & 0 & -1 & 0 & 0 \\ 0 & 0 & 0 & -\frac{1}{\hat{m}_{ref}} & 0 \\ 0 & 0 & 0 & 0 & -\frac{1}{\hat{m}_{ref}} \end{bmatrix} \quad (15)$$

Using (14) and (15) the parameter estimator can be implemented using the MIT rule given by (13) as shown in Figure 5.

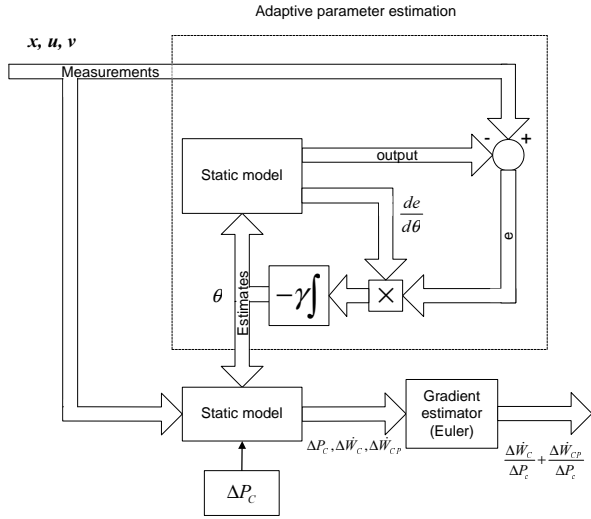

Fig. 5. Implementation of parameter estimator and condenser pressure set point optimizer.

Using this approach a lowpass filtering of the measurements through the integrator is obtained smoothing parameter estimates and removing most of the dynamics. Furthermore the parameters, which though are assumed constant, are enabled to adapt to un-modelled changes in the system.

Optimizing Controller

The power gradient is fed to the condenser pressure controller, which is implemented as a cascade controller, showed in Figure 6. This control setup enables relatively fast

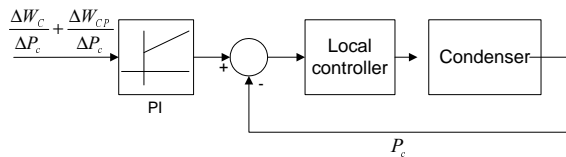

Fig. 6. The Condenser Pressure Control

dynamics in the inner loop, which helps keeping the system on the right track by suppressing disturbances. The slow integral action is moved to the outer loop, firstly because only slow performance of the optimizing control is required and secondly because the estimated value of power gradient actually only holds true near steady state.

VII. INEQUALITY CONSTRAINTS

Equality constrains on the states are in most cases fairly simple to deal with, because they can be kept constant by a local controller. As it can be seen from the example above with the evaporator pressure (P_e). Inequalities on the steady states are in this setup not either that hard to deal with, because they are predicted before they are reached (in the steady state prediction later, see Figure 1). This way they can just be applied with a high cost in the cost function, however it has to be done in a smooth way with a barrier function such that the cost function remains differentiable.

VIII. RESULTS

A dynamic model of the refrigeration cycle like shown in Figure 2 has been used in the simulation. The model consists of a lumped parameter moving boundary model of the evaporator (a plate heat exchanger), a lumped parameter model of the condenser (a shell and tube condenser) and static models of the expansion valve (a step motor controlled valve) and the compressor (a scroll compressor). A detailed description of the model can be found in (Larsen and Holm, 2002).

In Figure 7 the power consumed by the compressor and condenser pump using optimizing control is compared with a constant condenser pressure control. The minimal power consumption using the exact optimal set points is also indicated. The system is started under the following conditions:

Reference P_e	Reference SH	T_{wic}	T_{wie}
4.22 [bar]	5 [K]	17 [$^{\circ}C$]	27 [$^{\circ}C$]

After 10000 sec, the temperature T_{wic} is altered by a step from 17 to 7 $^{\circ}C$. Hereby as well the static as the dynamic properties of the control can be examined. In systems with air-cooled condensers (which are normally placed outside), will the ambient temperature be comparable with T_{wic} . A change in T_{wic} is therefore comparable with changes in the ambient temperature.

When the process settles after start-up, deviates the power consumption of the optimizing control 0.43% from the optimal set point and after the step the deviation is 0.03%. It is therefore possible within a relatively narrow margin to operate the system in the optimal state (under the given conditions). Furthermore it can be seen, that though the model is static it does not have any impact on the dynamic response of the power consumption, as previously stated. The optimizing control has been compared to a constant condenser pressure control strategy, which is a strategy widely used. It can be seen that even though the constant condenser pressure control has been started-up at an optimal set-point, the potential energy saving, after the step in T_{wie} is around 14%. In the light of this the deviations from the optimal set-point using the optimizing control are insignificant.

In the figure below 8, there has been made a step change

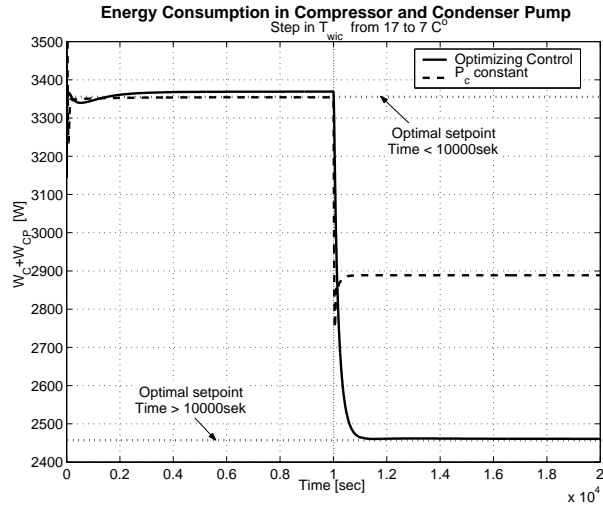

Fig. 7. Power consumption using the energy optimizing strategy compared to keeping the condenser pressure P_c constant. After 10000 sec is T_{wic} altered from 17 to 7°C

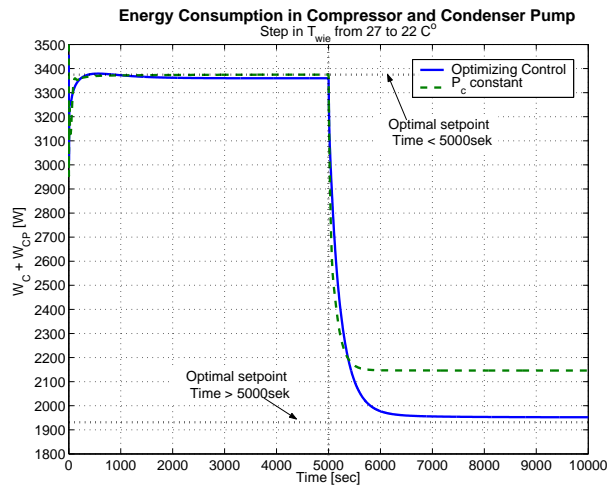

Fig. 8. Power consumption using the energy optimizing strategy compared to keeping the condenser pressure P_c constant. After 5000 sec is T_{wie} altered from 27 to 22°C

after 5000 sec in the inlet temperature to the evaporator (T_{wie}) from 27 °C to 22°C. Hereby the cooling capacity (\dot{Q}_e) changes. This means that a new value has to be estimated since it enters into the static model. As it can be seen from the dynamic response this adaption of the parameters (based on a static model) does not initiate any foul behavior. This is because the filtering removes much of the dynamics in the underlying distributed control systems.

IX. CONCLUSION

In this paper a method has been presented for on-line steady state optimization. The method provides a structure for a simple steady state optimization scheme for a strictly convex cost function or if the cost function declines globally towards the global optimum. However the method is also

applicable where the above mentioned conditions are not fulfilled, in these cases there is no guarantees that the setpoints converge to the global optimum. The application of energy optimization in a refrigeration system illustrated a case where the cost function is strictly convex and where the method can be implemented with promising results.

REFERENCES

- Åström, K. J. and B. Wittenmark (1989). *Adaptive Control*. 1 ed.. Addison-Wesley.
- Jakobsen, A., B.D. Rasmussen, M.J. Skovrup and J. Fredsted (2001). Development of energy optimal capacity control in refrigeration systems. In: *vol.1*. International Refrigeration Conference. Purdue.
- Larsen, L.S. and C. Thybo (2004). Potential energy savings in refrigeration systems using optimal setpoints. In: *Conference Proceedings*. CCA 2004. Taipei.
- Larsen, L.S. and J.R. Holm (2002). Modelling and control of refrigeration systems. *Master Thesis, Oersted DTU, Denmark*.
- Larsen, L.S., C. Thybo, J.Stoustrup and H. Rasmussen (2003). Control methods utilizing energy optimizing schemes in refrigeration systems. In: *vol.1*. ECC. Cambridge.
- Mølbak, Tommy (2003). Integrated model based optimisation of a power production system. In: *Conference Proceedings*. ECOS 2003. Copenhagen.
- Svensson, M. C. (1994). Studies on on-line optimizing control, with application to a heat pump. PhD thesis. Department of Refrigeration Engineering, The University of Trondheim.