



Cancer Research

Antitumor Immunotherapeutic and Toxic Properties of an HDL-Conjugated Chimeric IL-15 Fusion Protein

Maria C. Ochoa, Jessica Fioravanti, Inmaculada Rodriguez, et al.

Cancer Res 2013;73:139-149. Published OnlineFirst November 13, 2012.

Updated version Access the most recent version of this article at:
doi:[10.1158/0008-5472.CAN-12-2660](https://doi.org/10.1158/0008-5472.CAN-12-2660)

Supplementary Material Access the most recent supplemental material at:
<http://cancerres.aacrjournals.org/content/suppl/2012/11/12/0008-5472.CAN-12-2660.DC1.html>

Cited Articles This article cites by 25 articles, 14 of which you can access for free at:
<http://cancerres.aacrjournals.org/content/73/1/139.full.html#ref-list-1>

E-mail alerts [Sign up to receive free email-alerts](#) related to this article or journal.

Reprints and Subscriptions To order reprints of this article or to subscribe to the journal, contact the AACR Publications Department at pubs@aacr.org.

Permissions To request permission to re-use all or part of this article, contact the AACR Publications Department at permissions@aacr.org.

Antitumor Immunotherapeutic and Toxic Properties of an HDL-Conjugated Chimeric IL-15 Fusion Protein

Maria C. Ochoa¹, Jessica Fioravanti¹, Inmaculada Rodriguez¹, Sandra Hervas-Stubbs¹, Arantza Azpilikueta¹, Guillermo Mazzolini⁴, Alfonso Gúrpide², Jesus Prieto¹, Julian Pardo³, Pedro Berraondo¹, and Ignacio Melero^{1,2}

Abstract

Interleukin (IL)-15 effects on CD8 T and natural killer (NK) lymphocytes hold promise to treat cancer. Fusion proteins have been engineered to provide IL-15 receptor alpha (IL-15R α) mediated trans-presentation to lymphocytes and extend the plasma half-life of the cytokine. In this study, we report on a triple fusion protein combining apolipoprotein A-I (Apo A-I), IL-15, and IL-15R α 's sushi domain. Apo A-I conveys IL-15 to high-density lipoproteins (HDL), from which the cytokine is trans-presented by the IL-15R α 's sushi domain. Such a construction was tested by hydrodynamic gene transfer to the liver of mice. Lethal toxicity was observed upon injection of 10 μ g of the expression plasmid. Mice died from an acute lymphocytic pneumonitis in which T and NK cells dominate a severe inflammatory infiltrate. Importantly, mice devoid of NK cells were not susceptible to such toxicity and mice lacking granzymes A and B also survived the otherwise lethal gene transfer. Lower plasmid doses (<2.5 μ g) were tolerated and dramatically increased the numbers of NK and memory CD8 T lymphocytes in the liver, spleen, and lungs, to the point of rescuing the deficiency of such lymphocyte subsets in IL-15R α ^{-/-} mice. Doses of plasmid within the therapeutic window successfully treated metastatic tumor models, including B16OVA lung metastasis of melanoma and MC38 colon cancer liver metastasis. Sushi-IL-15-Apo as a recombinant protein was also bioactive *in vivo*, became conjugated to HDL, and displayed immunotherapeutic effects against metastatic disease. *Cancer Res*; 73(1): 139–49. ©2012 AACR.

Introduction

Interleukin(IL)-15 is a cytokine that has shown promising antitumor effects in preclinical studies (1), and clinical trials are currently ongoing (NCT01385423, NCT01369888, NCT01021059, and NCT01572493). The main mechanisms of actions against cancer are based on eliciting or favoring proliferation and activation of both natural killer (NK) and memory CD8 T cells (2). IL-15 is naturally expressed on the membrane of dendritic cells tethered to IL-15 receptor alpha (IL-15R α). This cytokine-receptor complex triggers

on cell-to-cell contacting lymphocytes, the heterodimeric receptor formed by the subunits IL-2R β and the common γ c (3). Activity on the IL-2R β / γ c complex is a property shared by IL-2 and IL-15. In marked contrast to IL-2, IL-15 seems to be a better tool for cancer immunotherapy, as IL-15 does not promote activation-induced cell death and does not induce proliferation of T regulatory cells (4).

One of the limitations of IL-15 to exert an efficacious antitumor effect is the short plasma half-life of the protein (5). For this reason, various approaches to increase its stability have been undertaken. Gene therapy with viral vectors (6), cells engineered to secrete IL-15 (7), and fusion proteins linking IL-15 to another larger protein fragment are among the possibilities to increase molecular weight and redirect the IL-15 to a specific target (8). As mentioned, it has been shown that IL-15 naturally acts as a trans-presented cytokine bound to the extracellular region of the IL-15R α (to a domain called sushi). Complexes of IL-15 and the sushi domain of the IL-15R α or fusion proteins containing both agents (9) have been used to strengthen its antitumor effect as a result of mimicking to some extent the naturally occurring trans-presentation mechanism (10).

Apolipoprotein A-I (Apo A-I) is the main protein component of the high-density lipoproteins (HDL) that circulate collecting cholesterol from tissues and bringing it to the liver (11). Apo A-I is an amphiphilic protein, naturally synthesized in the liver and which has been already used to stabilize IFN- α and target it to the liver (12).

Authors' Affiliations: ¹Center for Applied Medical Research, University of Navarra; ²Department of Oncology, Clinica Universidad de Navarra, Pamplona; ³Immune Effector Cells Group, Aragón Health Research Institute (IIS Aragón), Biomedical Research Centre of Aragón (CIBA), Nanoscience Institute of Aragón (INA), Aragón I+D Foundation (ARAID), University of Zaragoza, Zaragoza, Spain; and ⁴Gene Therapy Laboratory, Austral University, Avda. Presidente Peron, Buenos Aires, Argentina

Note: Supplementary data for this article are available at Cancer Research Online (<http://cancerres.aacrjournals.org/>).

P. Berraondo and I. Melero equally share senior authorship.

Corresponding Author: Ignacio Melero, Center for Applied Medical Research and Clinica Universidad de Navarra, University of Navarra, Av. PIO XII, 55, 31008 Pamplona, Spain. Phone: 34-948194700; Fax: 34-948194717; E-mail: imelero@unav.es

doi: 10.1158/0008-5472.CAN-12-2660

©2012 American Association for Cancer Research.

In a previous study, we constructed a plasmid coding for Apo A-I protein fused to hIL-15 (pApo-IL-15; Ochoa and colleagues, submitted for publication). This expression plasmid was transferred to the liver by hydrodynamic injection, thereby obtaining a high and sustained concentration of the protein in serum and a clear effect on the proliferation of NK and CD8 T cells. When the liver transference was conducted in combination with a separate plasmid coding for the sushi domain of IL-15 α (pSushi), the effect on NK and T cell proliferation was enhanced and certain antitumor effects were attained albeit to a modest extent.

In the current study, we have designed and tested a triple fusion protein encompassing the sushi domain of the IL-15 α , IL-15, and Apo A-I.

Materials and Methods

Mice and cell lines

C57BL/6 mice (6–10-weeks old) were purchased from Harlan Laboratories. Rag1^{-/-}, Rag2^{-/-}IL-2R γ ^{-/-}, and IL-15 α ^{-/-} mice were obtained from The Jackson Laboratory. GzmAxB^{-/-} and perfxgzmAxB^{-/-} mice (C57BL/6 background) were kindly provided by Dr. Julian Pardo (University of Zaragoza, Zaragoza, Spain). They are homozygous triple knockout for granzymes A and B and perforin. They were originally created by crossing perf^{-/-} with gzmAxB^{-/-} mice (13). These mice were maintained under pathogen-free conditions in the animal facilities of CITA (Agrifood Research and Technology Centre of Aragon) in Zaragoza, Spain. Mouse genotypes were periodically tested by PCR as previously described (13). B16OVA melanoma-derived cells were B16F10 cells transfected to express chicken ovalbumin (OVA) and have been described previously (14). MC38 is a colon adenocarcinoma cell line of C57BL/6 origin (15). B16OVA and MC38 cell lines were validated by Idexx Radill in 2012 (February) using a panel of microsatellite markers for genotyping.

Cell lines were maintained at 37°C in 5% CO₂ and were grown in RPMI medium (RPMI-1640) with GlutaMax (Gibco, Invitrogen) containing 10% heat-inactivated FBS (Sigma-Aldrich), 100 IU/mL penicillin, 100 g/mL streptomycin (Bio-whittaker), and 50 mmol/L 2-mercaptoethanol (Gibco). CTLL-2 is a stable subclone of cytotoxic T lymphocytes originally isolated from a C57BL/6 mouse and 200 U/mL of IL-2 (Preprotech) was added in its culture medium (16). Peripheral blood mononuclear cell (PBMC) were obtained from filters of blood donation units under informed consent following approval of the Institutional Ethical Committee, carboxyfluorescein succinimidyl ester (CFSE) stained and monitored as described (17). Details on the isolation of mononuclear cells from spleen, lung, and liver, as well as antibodies, flow cytometry, and immunohistochemistry can be found in Supplementary Methods.

Plasmids

For sushi domain construction (pSushi), kindly provided by Dr. Bulfone-Paus (Research Center Borstel, Borstel, Germany), complete mIL-15 α was cloned into the *Bam*HI

and *Not*I sites of the vector pcDNA3.1 (Invitrogen). The C-terminal part was removed by PCR (Uprim. TAAA-GAGGGCCCTATTCTATAGTG and Lprim. GGGGTCTCTG-ATGCACTTGAG) and subsequent ligation of the product.

Apo A-I plasmid cloning (pApo) were designed using, the sense primer (FwATGmApoA1) 5'-ATGAAAGCTGTGGTGTGGC-3' and the antisense primer 5'-TCACTGGGCAGTCA-GAGTCT-3' (RvTGAmApoA1). It was amplified by PCR on liver total cDNA and purified from an agarose gel with a QIAquick Gel Extraction Kit (Qiagen). Purified cDNA was cloned in the expression vector pcDNA3.1/V5-His TOPO TA (Invitrogen, Carlsbad; ref. 12).

For Apo A-I and human IL-15 (pApo-IL-15) plasmid construction, a PCR amplification was carried out using the sense primer FwATGmApoA1 on pApo as a template, and the antisense primer RvAscImApoA1 (5'-GGCGGCCCTGGGCAGTCAGAGTCTCGC-3'), introducing the restriction site for the *Asc*I enzyme (GGCGGCCCC) in 3' end of *Apo A-I* gene, eliminating the stop codon and including a GTPase-activating protein (GAP) peptide as linker of the 2 codified proteins. mApoA-I-*Asc*I-purified cDNA was cloned in the expression vector pcDNA3.1/V5-His TOPO TA (Invitrogen). Human IL-15 sequence was cloned in the expression vector pTrcHis2 TOPO TA (Invitrogen) using 5'AATAATG-GCGCGCCGAAGTGGATAGATG-3' (FwAscIhIL-15) and 3' GCGGCCGCTCAGGACGTGTTGATGAAC-5' (RvNotIhIL-15) primers that introduced a restriction site for *Asc*I enzyme in 5' and *Not*I in 3'. pTrcHis2-hIL-15 was digested with *Asc*I and *Not*I and the *Asc*I-hIL-15-*Not*I DNA fragment (345 nt) was obtained. To carry out the gene fusion, plasmid pCMV-mApoA1-*Asc*I was digested with the *Asc*I/*Not*I enzymes (New England Biolabs). The ligation was conducted with the open plasmid pCMV-mApoA1-*Asc*I and the *Asc*I-hIL-15-*Not*I insert in an 1:3 (vector:insert) ratio using T4 DNA ligase High Concentration and 2 \times Rapid Ligation Buffer (Promega). The resulting 6669-nucleotide plasmid will hereinafter be called pApo-IL-15. All plasmids were confirmed by sequencing. In our hands, there are no differences of mouse and human IL-15 on functional data with CTLL2 cells (data not shown).

To fuse mSushi-mIL-15 with ApoA-I, PCR amplification was carried out using the primers (Fw 5'-ATGGAGACAGACACCCTGCTG-3') and (Rv 5'-GGCGCGCCGCTGGTGTGGATGAACAT-3') on pSushi-IL-15 (kindly donated by Dr. Bulfone-Paus) as a template. The antisense primer introduces the restriction site for the *Asc*I enzyme in 3' end of *mSushi-mIL-15* gene and eliminates the stop codon. The resulting purified DNA product was cloned into the pcDNA3.1/V5-His TOPO TA expression vector (Invitrogen), obtaining the plasmid pCMV-mSushi-mIL-15-*Asc*I. To carry out the gene fusion, plasmids pCMV-*Asc*I-mApoA1 (12) and pCMV-mSushi-mIL-15-*Asc*I were digested independently with the *Asc*I/*Nco*I enzymes (New England Biolabs). The open plasmid pCMV-mSushi-mIL-15-*Asc*I and the -*Asc*I-mApoA1 insert were ligated in a 1:3 (vector:insert) ratio using T4 DNA ligase High Concentration and \times 2 Rapid Ligation Buffer (Promega). The resulting plasmid will hereinafter be called pSushi-IL-15-Apo.

Hydrodynamic injections

The plasmids were transferred by an intravenous injection (tail vein) of plasmid in a volume of 100 mL/kg using a 27-G needle at a rate of 0.4 mL/s, as previously described (18).

In vivo tumor growth

For the intrasplenic tumor model, C57BL/6 mice received an injection of MC38 cells in the surgically exposed spleen (5×10^5 per mouse). On day 1 or 4, mice were treated with the corresponding plasmid by hydrodynamic injection. These mice were sacrificed after 19 days and tumor nodules in spleen and liver surface metastasis were counted and measured.

For the B16OVA-derived lung tumors model, C57BL/6 mice received an intravenous injection of B16OVA cells (5×10^5 per mouse). On day 1, mice were treated with the plasmids or 50 μ g of the Sushi-Apo-IL-15 protein. The mice were sacrificed on day 14 and tumor nodules in lung surface were counted and measured.

rSushi-IL-15-Apo, electrophoresis, and Ponceau staining

Recombinant Sushi-IL-15-Apo protein with 6 \times HIS tag was produced by Genscript.

To visualize the purity of rIL-15-Sushi-Apo, 10 μ g were separated in 4% to 20% TrisHEPES PAGE LongLife iGels (Nusep) gradient gels, and transferred to a nitrocellulose membrane (Whatman). Total protein was visualized by Ponceau staining.

Sushi-IL-15-Apo bioactivity assay

CTLL2 cells were washed 3 times with PBS and cells in RPMI medium was plated in a 96-well plate (10^4 cells per well in 50 μ L). Recombinant mIL-15 or Sushi-IL-15-Apo proteins were added at the described concentrations. The plates were then incubated for 2 days and subsequently, the microcultures were pulsed with 0.5 μ Ci of tritiated thymidine ($[^3\text{H}]\text{TdR}$) 8 hours before being harvested. Cells were harvested using a Micro Beta Filter Mate-96 harvester (PerkinElmer) and $[^3\text{H}]\text{TdR}$ incorporation to the nuclei adsorbed onto the filters was measured using an automated Topcount liquid scintillation counter (Packard).

pSTAT-5 detection after culture with rSushi-IL-15-Apo

Splenocytes of C57BL/6 mice were isolated and incubated 30 minutes at 37°C in RPMI medium and 0.5 μ g/mL of IL-15 or rSushi-IL-15-Apo. Then, the cells were fixed with an equal volume of 37°C prewarmed BD Cytofix Buffer (BD Biosciences) during 15 minutes. Cells were then permeabilized with BD Phosflow perm Buffer III (BD Biosciences) for 30 minutes in ice-cold solution and were stained with the different antibodies and analyzed by flow cytometry.

Results

Liver gene-transfer of pSushi-IL-15-Apo induces a lethal toxic effect due to inflammatory infiltrates of NK and CD8 T lymphocytes in the lung

The pSushi-IL-15-Apo expression plasmid was administered by hydrodynamic injection to C57BL/6 mice. Injection

of 10 μ g of expression plasmid resulted in the onset respiratory distress as early as 48 to 72 hours later and in the death of 100% of the mice within 3 to 4 days after the hydrodynamic injection procedure (Fig. 1A). To ascertain the cause of death, mice were euthanized when the respiratory distress was clearly observed by inspection (day 3 after gene transfer), and following euthanasia a thorough necropsy examination was conducted. Lungs seemed congestive and erythematous. Lung histologic staining with hematoxylin and eosin (H&E) and α -CD3 monoclonal antibody (mAb) immunohistochemistry was carried out (Fig. 1B). An abundant inflammatory infiltrate was observed in the lungs of mice treated with 10 μ g of pSushi-IL-15-Apo. Such an infiltrate was reduced when the plasmid dose was 1 μ g. Moreover, flow-cytometry analysis of the lung lymphocyte infiltrates showed high amount of NK and NKT cells retrieved from the lungs of mice treated with 10 μ g of pSushi-IL-15-Apo. The inflammatory infiltrates in those mice treated with 1 μ g of the expression plasmid were clearly of more modest intensity (Fig. 1C). The quantity of CD8⁺ CD44⁺ T cells in the lungs was similar in mice treated with 10 μ g or 1 μ g of pSushi-IL-15-Apo.

Next, experiments in gene-modified mice were undertaken to identify the mechanisms involved in toxicity. 10 μ g of pSushi-IL-15-Apo were transferred to the liver of wild-type (WT), Rag 1^{-/-} and Rag2^{-/-} γ c^{-/-} mice. Only Rag2^{-/-} γ c^{-/-} mice lacking both T and NK cells survived longer than 5 days (Fig. 2A) and made a full recovery. To explore the requirement for NK cells, WT and Rag 1^{-/-} mice were depleted of NK cells with anti-asialo GM1 (Wako), or alternatively, were depleted of NK and NKT cells with α -NK1.1 mAb. When such mice received 10 μ g of pSushi-IL-15-Apo, the construction was not lethal for those mice whose NK cells had been depleted with α -asialo GM1 (Fig. 2B). In the group of Rag 1^{-/-} mice that received α -NK1.1 mAb, there was a residual lethality but it was reduced to 60%.

The molecular requirements of the NK effectors for the observed lethal effects were explored in subsequent experiments. Hydrodynamic gene transfer of 10 μ g of pSushi-IL-15-Apo to mice knocked out for the genes of granzymes A and B did not cause overt toxicity (Fig. 2C). This also was true in perforin, granzymes A and B triple knockout mice. These data clearly indicate that the lethal toxicity of the pSushi-IL-15-Apo is due to the cytotoxic granule machinery of the NK cells. Additional candidates as possible mediators of the toxicity were explored injecting the plasmid to knockout mice for the following genes: *IFN- γ* , *IFN- α* receptor, the receptor of the Apo A-I (*SR-BI*), and *Apo A-I* (Supplementary Fig. S1). There were no differences in the survival of those mice and WT mice, suggesting that none of those molecules and pathways played a key role in the toxic effect. We also neutralized TNF- α with a TNF-R-Fc chimera without any noticeable change in the acute toxicity profile. Two main conclusions were drawn: (i) the novel construct had a likely on-target side effect causing an acute NK cell pneumonitis; and (ii) such an undesired effect was dose-dependent, thus offering a potential therapeutic window.

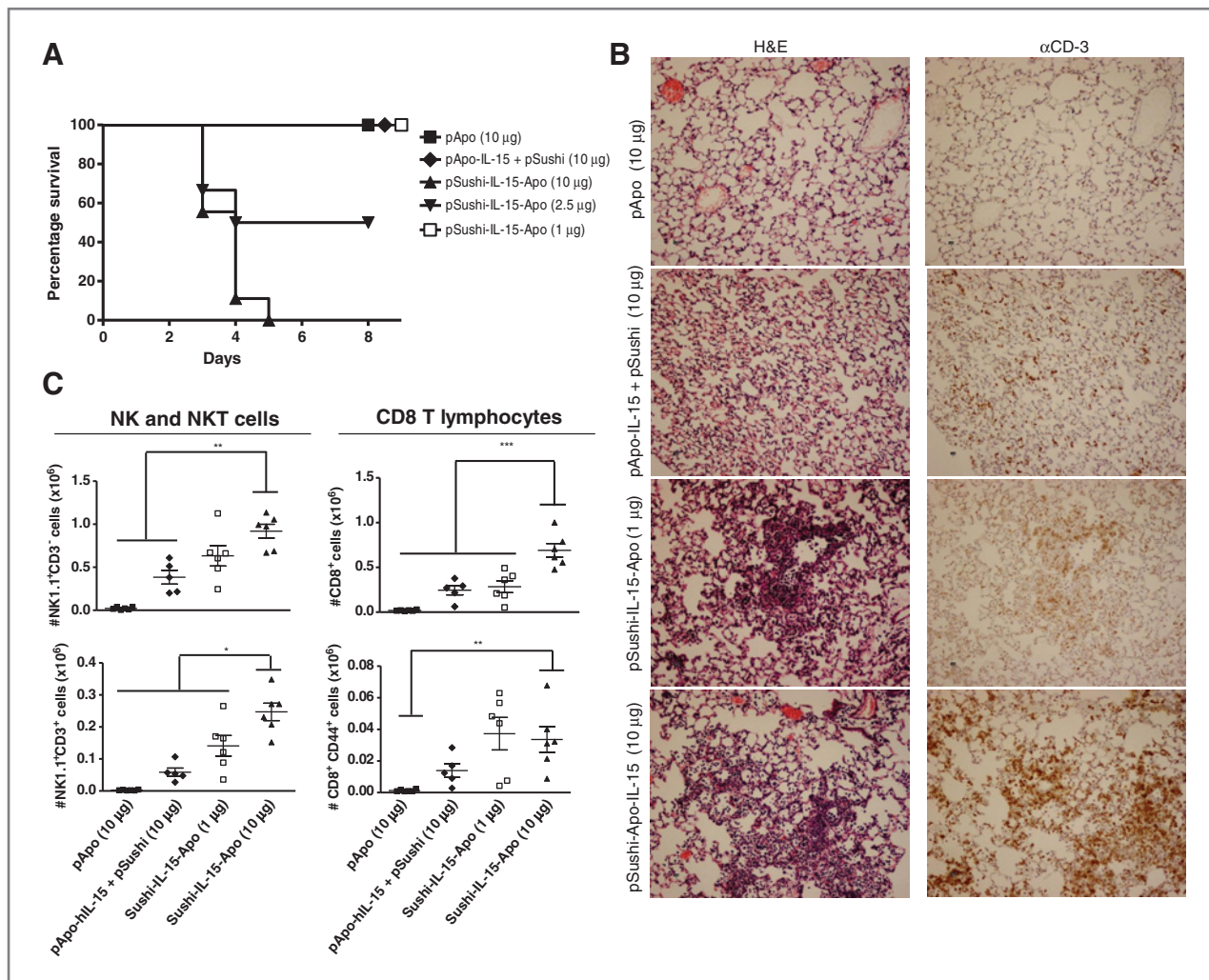

Figure 1. Lethal lymphocytic pneumonitis in mice that receive hydrodynamic gene transfer of pSushi-IL-15-Apo. **A**, survival follow-up, as shown by a Kaplan–Meier graph of C57Bl/6 mice ($n = 6$ per group) given a hydrodynamic gene transfer of the indicated expression plasmids at the indicated doses on day 0. This experiment has been repeated twice rendering similar results. **B**, microphotographs (magnification, $\times 200$) of lungs excised from mice treated with the indicated plasmids and doses 72 hours before euthanasia. Mice receiving pSushi-IL-15-Apo at 10 μg showed severe signs of respiratory distress at the moment of sacrifice in all cases. Tissue sections were stained with H&E (left) or with an anti-CD3 mAb (right). **C**, changes in NK, NKT, and CD8 T lymphocyte subsets in the lungs as assessed by flow cytometry on cell suspensions 3 days after receiving the indicated expression plasmids by hydrodynamic injection. *, $P < 0.05$; **, $P < 0.01$; and ***, $P < 0.001$ in an ANOVA test between the indicated groups.

A tolerable dose of pSushi-IL-15-Apo induces an increase in the number of NK and CD8 T cells

The dose of 1 μg of expression plasmid transferred by hydrodynamic injection to the liver was tolerated without any signs of distress. The follow-up of the serum concentration of the protein was analyzed by a commercial ELISA for mIL-15. The administration of 1 μg of pSushi-IL-15-Apo yielded a significantly lower concentration of Sushi-Apo-IL-15 protein at 24 hours than those obtained with 2.5 or 10 μg of plasmid (Supplementary Fig. S2A). To study in a bioassay that Sushi-IL-15-Apo was bioactive, CTLL2 cells (that need IL-2 or IL-15 to proliferate) were incubated with sera from mice that had received a hydrodynamic injection of 1 μg of pSushi-IL-15-Apo. Sera from these mice induced

proliferation in CTLL2 cells, as measured by [^3H]TdR incorporation (Supplementary Fig. S2B).

Moreover, the different lipid fractions of the serum were fractionated by ultracentrifugation and the fraction containing the HDL was tested in the cultures of CTLL2 (Supplementary Fig. S2C), showing that at least a part of the functional triple fusion protein becomes complexed to HDL. These data were confirmed by immunoblotting, as a clear band of the corresponding shifted molecular weight for the triple fusion was detected with an anti-Apo A-I antibody (Supplementary Fig. S2D).

Our results do not offer evidence for clear superiority of pSushi-IL-15-Apo over pSushi-IL-15. Nonetheless, if mice are hydrodynamically injected with these expression constructs,

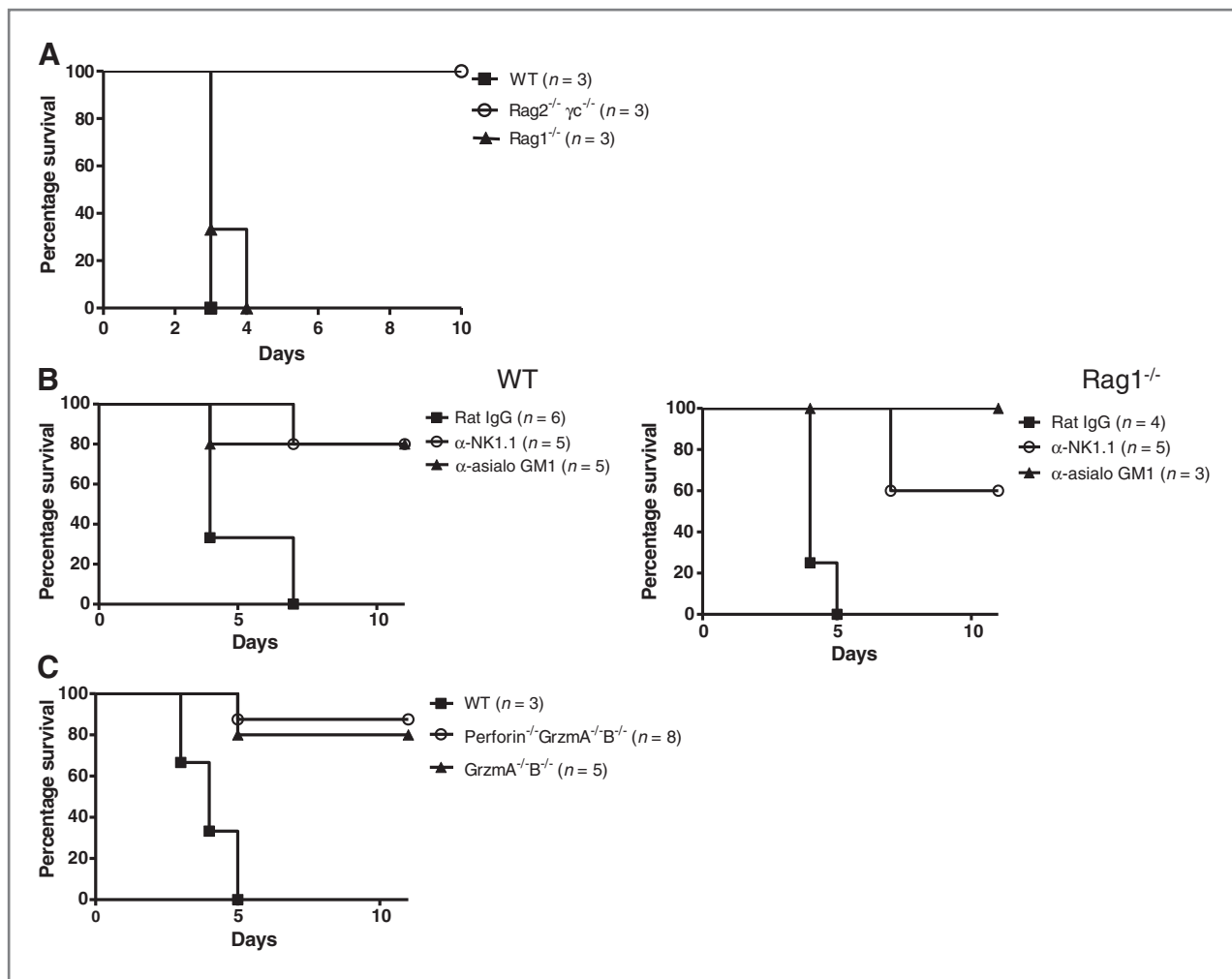

Figure 2. NK cells and their cytolytic machinery are required for pneumonitis lethality. **A**, WT and gene-modified mice were given pSushi-IL-15-Apo at 10 μ g per dose on day 0. Survival was daily monitored and shown in a Kaplan-Meier graph. **B**, similar experiments in WT and Rag1^{-/-} mice but in the indicated groups, NK and NKT cells were codepleted with anti-NK1.1 mAb or NK cells were eliminated with anti-asialo GM1 antiserum given on days -4, -3, 0, and +2. Depletion efficacy was confirmed in peripheral blood on day 0. **C**, similar experiments as in **A** and **B** in mice genetically deficient of granzymes A and B or perforin and granzymes A and B as indicated. Experiments are representative of at least 2 repetitions.

the 48-hour serum samples from these animals exerts proliferative bioactivity on CTLL2 cells when tested in multiple serial dilutions (Supplementary Fig. S2D). This suggests that the Sushi-IL-15-Apo transgene is more bioactive in this treatment setting.

The hydrodynamic injection of 1 μ g of pSushi-IL-15-Apo increased the number of lymphocytes in spleen, liver, and lung 6 days after the plasmid injection. The number of NK cells (NK1.1⁺CD3⁻) was much higher in mice treated with 1 μ g of pSushi-IL-15-Apo than in control mice that received pApo and similar to those mice that received a hydrodynamic injection with 10 μ g of pApo-IL-15 and pSushi in separate plasmids. In contrast, the number of CD8⁺CD44⁺ T cells was clearly higher in mice with the pSushi-IL-15-Apo treatment than in mice injected with both pApo-IL-15 and pSushi as separate expression constructs (Fig. 3A).

A separate study on the kinetics of these effects showed that the increases in the number of NK and CD8⁺CD44⁺ T cells in spleen, liver, and lung of mice treated with the triple construction peak around day 7 postinjection and then progressively declines to reach normal values at day 15 (Supplementary Fig. S3). In contrast, the administration of the pApo-IL-15 and the pSushi in separate plasmids showed different kinetics, with the highest increase of NK and CD8 lymphocytes around day 4. Lymphocyte proliferation was observed *in vivo* by BrdUrd incorporation. Lymphocytes in mice transferred with pSushi-IL-15-Apo showed a more intense proliferation than mice that received pApo or separate pApo-IL-15 + pSushi constructions (Supplementary Fig. S4).

IL-15R α ^{-/-} mice are almost totally devoid of NK and NKT cells and have a severe reduction in memory-phenotype CD8 T cells (19). Hydrodynamic injection of 1 μ g of pSushi-IL-15-Apo

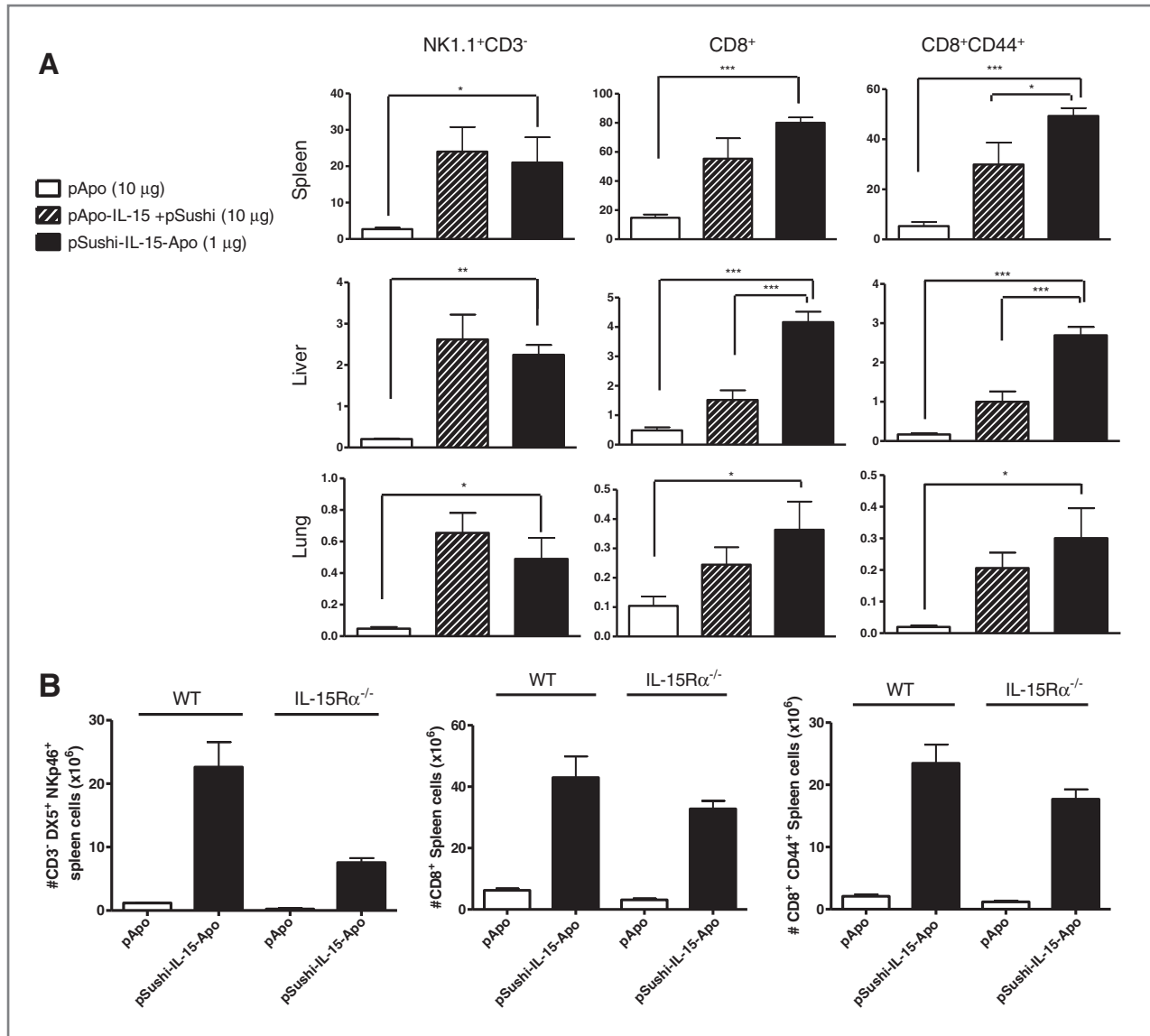

Figure 3. Effects of liver gene transfer with pSushi-IL-15-Apo on the lymphocyte contents in lung, liver, and spleen that attain the reversal of the T and NK deficient phenotype characteristic of IL-15R $\alpha^{-/-}$. **A**, mice were injected by hydrodynamic injection of the indicated plasmids and 5 days later cell suspensions were prepared from spleen, liver, and lungs. Flow cytometry analyses were conducted to count the absolute numbers of the indicated lymphocyte subsets as referred to the total lymphocytes recovered from the organ. Data are presented as absolute number of cells $\times 10^6$ (mean \pm SEM). **B**, IL-15R $\alpha^{-/-}$ mice or control WT mice were treated with 1 μ g of the indicated plasmids by hydrodynamic injection and NK and CD8 T cells were studied 6 days later by flow cytometry in cell suspensions obtained from the spleen. *, $P < 0.05$; **, $P < 0.01$; and ***, $P < 0.001$ in an ANOVA test between the indicated groups.

in IL-15R $\alpha^{-/-}$ mice reverses the phenotype, dramatically increasing the number of NK and CD8⁺CD44⁺ T cells to almost the level observed in WT mice with the same treatment (Fig. 3B).

pSushi-IL-15-Apo transferred to the liver at a tolerated dose exerts antitumor effects against metastatic tumors

The antitumor effect of the tolerable dose (1 μ g) of pSushi-IL-15-Apo was studied in a model of B16OVA spread to the lungs following intravenous inoculation of the tumor cells. In a first pool of experiments, we observed that the group of mice treated with 1 μ g of pSushi-IL-15-Apo the following day of tumor cell administration had less lung metastases than

the other groups of mice when the experiment was terminated at day 14 (Fig. 4A). A photograph of 3 representative excised lungs of each group is shown in Fig. 4B. Next, an experiment was carried out treating the mice at day 4 after intravenous tumor inoculation and the number of lung metastases in the group of mice treated with pSushi-IL-15-Apo at day 4 was clearly lower than in the control group and similar to the group that received the treatment the day following the tumor injection (Fig. 4C).

To study the antitumor effector lymphocytes in this setting, an experiment was carried out in Rag1^{-/-} and WT mice depleted of CD8 β or NK1.1⁺ cells (Fig. 4D). In mice

Figure 4. pSushi-IL-15-Apo gene transfer to the liver ameliorates melanoma lung metastasis of B16OVA. A, mice were intravenously injected with 5×10^5 B16OVA melanoma cells. One day later, mice received the indicated doses of expression plasmids by hydrodynamic injection. Fourteen days later, mice were sacrificed and the number of melanocytic lesions in the surface of the lung was enumerated or confirmed to be more than 200. Statistic comparisons were made by one-way ANOVA with Bonferroni corrections test; $***, P < 0.001$. Data are pooled from 2 independent experiments with different symbols (squares and triangles) representing the mice from each of the pooled experiments. B, representative photographs of a fraction of lungs from A. C, mice treated as in A, but hydrodynamic gene transfer was given on day +1 or +4 as indicated. D, experiments as in A but when indicated, mice were depleted on days -4, -3, 0, and +2 with anti-CD8 β mAb or anti-NK1.1 mAb. The indicated groups of mice were Rag1 $^{-/-}$ in C57Bl/6 background.

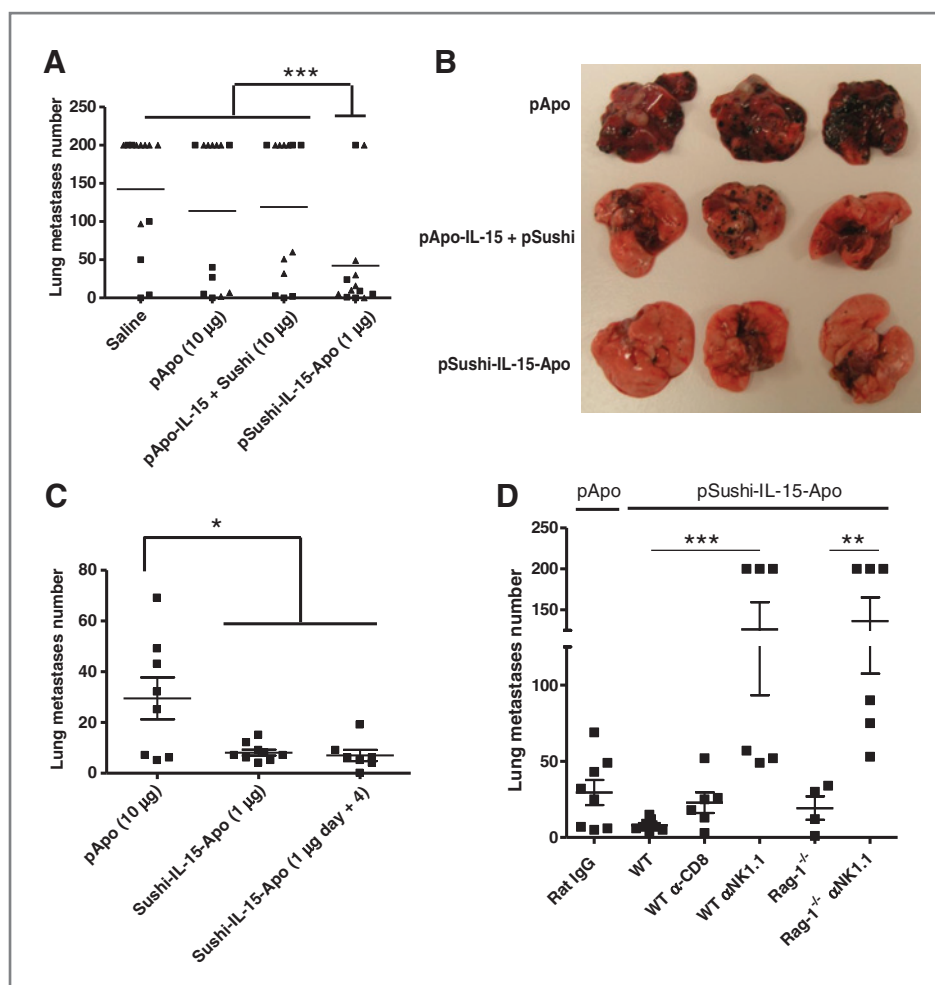

without NK cells, the tumors grew faster than in WT without treatment and in those depleted of CD8 $^{+}$ T cells the treatment was not effective, suggesting that the antitumor effect is mediated by the interplay of both NK and CD8 T cells.

Next, the antitumor therapeutic effects were tested in a model of MC38-derived liver metastases. The colorectal carcinoma cells were injected in the spleen, in which a primary tumor grew and then metastatic tumors disseminated into the liver. Mice were treated with the different expression plasmids 1 day after undergoing intrasplenic inoculation of the colon carcinoma cells. Nineteen days later, the livers were harvested and the metastases on the surface of this organ were counted. Mice that had received 1 µg of pSushi-IL-15-Apo were 100% metastasis-free in the liver (Fig. 5A). In addition, the spleens were examined and weighed to reflect the primary tumor size (Fig. 5B). Fifty percent of mice from the group treated with pSushi-IL-15-Apo did not present any macroscopic tumor in the spleen, whereas 100% of mice from the saline group had spleen tumors, 67% from the pApo group, and 100% of the pApo-IL-15 + pSushi group.

Sushi-IL-15-Apo recombinant protein administered intravenously is bioactive and elicits antitumor effects

Clinical feasibility of this treatment would benefit from using a recombinant protein as the therapeutic agent instead of conducting cumbersome gene therapy procedures. The recombinant protein was produced in *Escherichia coli* and purified by affinity chromatography. SDS-PAGE and Ponceau staining were carried out to analyze the purity and integrity of the protein (Fig. 6A). In addition, the bioactivity of the protein was studied with a CTLL2 proliferation bioassay (Fig. 6B), and such bioactivity was also checked in terms of an assay to detect STAT-5 phosphorylation in primary lymphocytes. For the latter purpose, splenocytes were incubated overnight with recombinant IL-15 or rSushi-Apo-IL-15 and then intracellular pSTAT-5 was studied by flow cytometry in T and NK cells. As can be seen in Fig. 6C, rSushi-IL-15-Apo induced pSTAT-5 phosphorylation in NK and memory-phenotype CD8 T cells. Moreover, intravenous injection of rSushi-Apo-IL-15 produced dose-dependent increases in the number of NK and memory CD8 T lymphocytes in the spleen, liver, and lung (Supplementary Fig. S5).

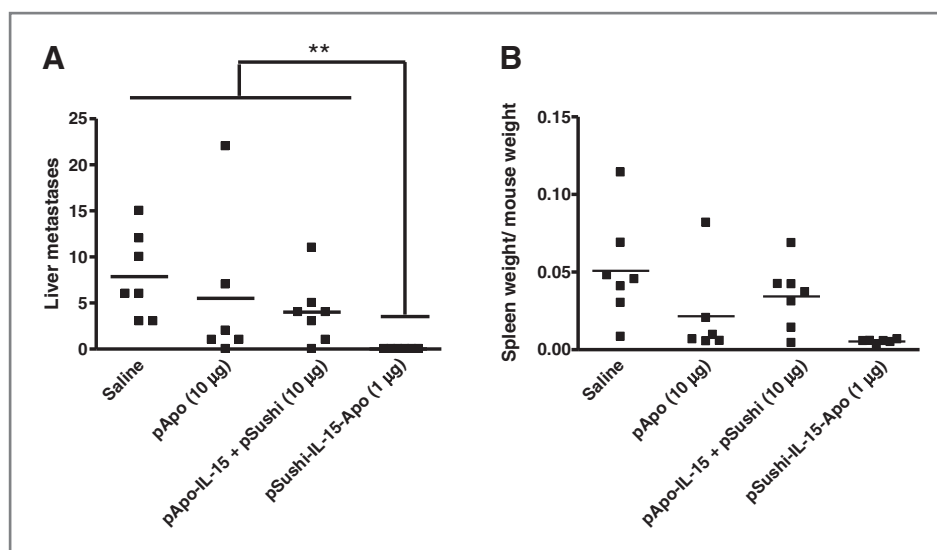

Figure 5. pSushi-IL-15-Apo hydrodynamic gene transfer is active against liver metastases of MC38 colon carcinoma. A, mice were injected with 5×10^5 MC38 colon cancer cells on day 0 inside the surgically exposed spleen. On day 1, mice received hydrodynamic gene transfer of the indicated plasmid or plasmid combinations. Excised livers were inspected on day +19 and the number of metastases on the surface of hepatic lobes was counted. Statistic comparisons were made with one-way ANOVA followed by Bonferroni corrections; **, $P < 0.001$. B, the ratio of spleen weight to total weight of the mouse to reflect the size of the splenic tumor. In the pSushi-IL-15-Apo group 4 of 8 mice were tumor-free in the spleen.

To ascertain if this fusion protein was active on human lymphocytes, CFSE-labeled PBMC from healthy volunteers were injected into the peritoneal cavity of $Rag2^{-/-}IL-2R\gamma^{-/-}$ mice. Such mice were intravenously treated with $50 \mu\text{g}$ of recombinant Sushi-IL-15-Apo or saline. As can be seen in Fig. 6D, gated human NK and CD8 T cells retrieved 6 days later from the peritoneum had proliferated in response to the injected fusion protein. This is consistent with previous studies using IL-15 forms engineered to be transpresented (20).

The antitumor activity of the recombinant protein rSushi-IL-15-Apo was tested in the B16OVA lung metastasis model. Tumor progression in mice that received $50 \mu\text{g}$ of rSushi-IL-15-Apo intravenously on day +1 was similar to that observed in mice in which $1 \mu\text{g}$ of the pSushi-IL-15-Apo construction was transferred to the liver by hydrodynamic injection 1 day after tumor cell inoculation (Fig. 7). ELISA assays conducted following each type of treatment showed that the serum concentrations achieved by $1 \mu\text{g}$ hydrodynamic injection that are in the range of 200 to 300 pg/mL following injection of the plasmid are also observed around 30 minutes after intravenous injection of $50 \mu\text{g}$ of the triple fusion protein (data not shown). Both groups treated with Sushi-IL-15-Apo, as gene therapy or recombinant protein, presented less metastatic foci in the lungs than the non-treated control group.

Discussion

We have analyzed the immune and antitumor effects of liver gene transfer of a construction coding for the sushi domain of IL-15 α , IL-15, and Apo A-I. We have shown that the liver gene transfer of the triple fusion is highly toxic at any dose higher than $2.5 \mu\text{g}$ of plasmid per mouse, mainly

due to the accumulation of NK cells in the lungs. Such a lethal inflammatory effect is dependent on granzymes A and B and perforin. Toxic effects related to IL-15 have been described in transgenic mice that continuously produce IL-15 (21). Those mice die from NK or T leukemias when 12- to 30-weeks old. Other transgenic strains of mice that express human IL-15 also develop leukemia when they are older than 12 months (22). However, to our knowledge, this is the first time that an acute lethal toxic effect is described following IL-15 treatment, giving an idea about the potency of the chimeric construction that we report.

We had previously studied Apo-IL-15 noncovalently linked to IL-15 α and it is clear that both biologic effects and toxicity are much less pronounced. This is interpreted in the sense that covalent bounds enforce IL-15 trans-presentation by the IL-15 α sushi domain (2). Accordingly, this triple fusion cytokine represents a highly active form of IL-15. The Apo A-I that forms part of the HDLs conceivably acts as a natural vehicle that facilitates the IL-15/IL-15 α sushi domain anchorage for trans-presentation. Another advantage of Apo A-I is that this protein has been reported to exert some not well-understood antitumor properties (23).

For clinical translation, our observations on acute toxicity might look worrisome. However, it must be taken into account that because of using gene therapy, we are clearly overdosing the cytokine. In a sense, finding a maximal-tolerated dose suggests that our construct is making the most of the IL-15 system. This is important for translation as IL-15 enjoys the reputation of a great potential in immunotherapy (24) with a very safe preclinical profile.

The activity observed with the recombinant protein is a step forward toward clinical translation. In the case of this construct, exogenous administration of protein at reliably

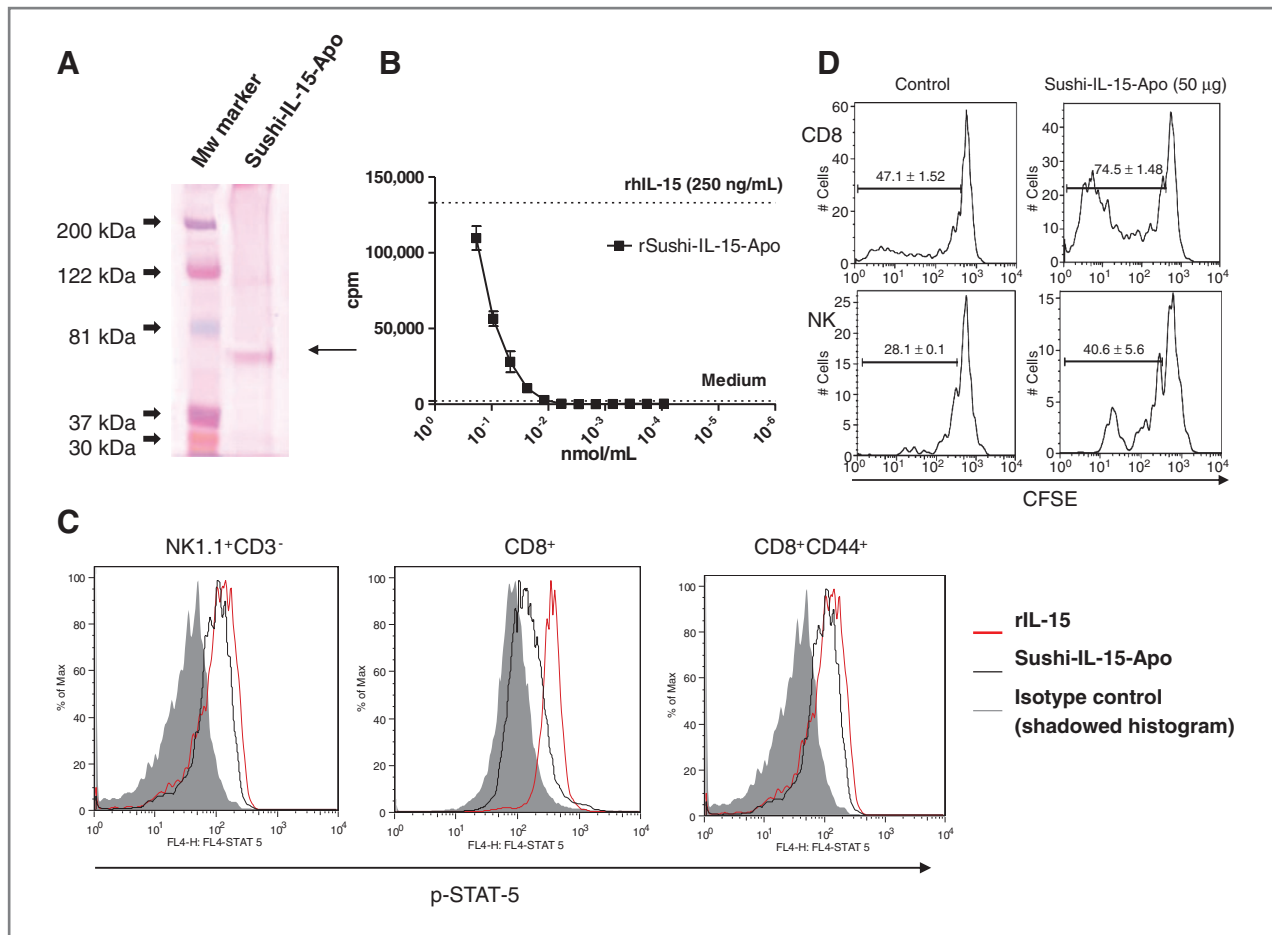

Figure 6. A purified recombinant Sushi-IL-15-Apo fusion protein is functional. **A**, SDS-PAGE analysis developed by Ponceau staining of rSushi-IL-15-Apo produced in *E. coli* and purified by affinity chromatography. **B**, bioassays of serial dilutions of the Sushi-IL-15-Apo recombinant protein on CTLL2 cells. Proliferation was assessed in triplicate wells. Data are representative of at least 2 experiments similarly carried out. The discontinuous line marks the proliferation induced by 250 ng/mL of commercial rIL-15 as indicated. **C**, levels of STAT5 phosphorylation upon intracellular immunostaining presented in overlaid histograms of spleen lymphocytes exposed in culture to rSushi-IL-15-Apo or rIL-15 for 30 minutes as indicated. Background staining with an isotype and fluorochrome matched control antibody is given (shadowed histogram). NK, CD8, and memory CD8 T lymphocytes were flow cytometry-gated by multicolor immunostaining and data for each subset are presented in different histograms. Experiments are representative of at least 3 carried out with similar results. **D**, 10⁷ human PBMC from healthy volunteers were labeled with CFSE and injected to the peritoneal cavity of Rag2^{-/-}IL-2Rγ^{-/-} mice. Mice received intravenous injections 50 µg of rSushi-IL-15-Apo or saline as indicated in the figure. Histograms represent CFSE dilution in gated NK and CD8 human lymphocytes 6 days after infusion. A representative peritoneal lavage out of 2 conducted is shown and the percentages of proliferated cells are given in each histogram.

controlled levels is probably safer. The only advantage of the gene therapy approach used for the proof-of-concept experimentation is that the liver is the natural bioreactor of HDLs in the organism. Indeed, the approach with recombinant proteins is the most feasible for translation. Other groups have used linked forms of IL-15Rα to IL-15 (9) with biologic effects on lymphocytes as well as with therapeutic effects on transplanted tumors (10). It is early to decide without comparative studies which of these fusion proteins will offer the best and safest pharmacokinetics and pharmacodynamics but incorporation into lipoproteins may have advantages.

The effectiveness of the therapy is particularly remarkable against B16OVA-derived metastasis even when given 4 days after tumor cell inoculation. This observation on efficacy against lung tumors could be related to the propensity of NK

cells and CD8 T lymphocytes to infiltrate the lung under these therapeutic conditions. In this regard, toxicity is considered an on-target side effect for which a therapeutic window was found. Human malignancies progress more slowly than mouse-transplanted tumors. Therefore, we tested if doses can be repeated to weeks apart in mice, and we found that the increases in NK and CD8 memory T cells were comparable or even higher 4 days after the second hydrodynamic treatment. Accordingly, repeated doses seem to be feasible without desensitization or cumulative toxicity (Supplementary Fig. S6).

Apo A-I-linked cytokines may add interesting immunotherapeutic properties (12). In this case, Sushi-IL-15-Apo holds promise for metastatic disease and deserves clinical development. We eagerly expect results for the first human trials of

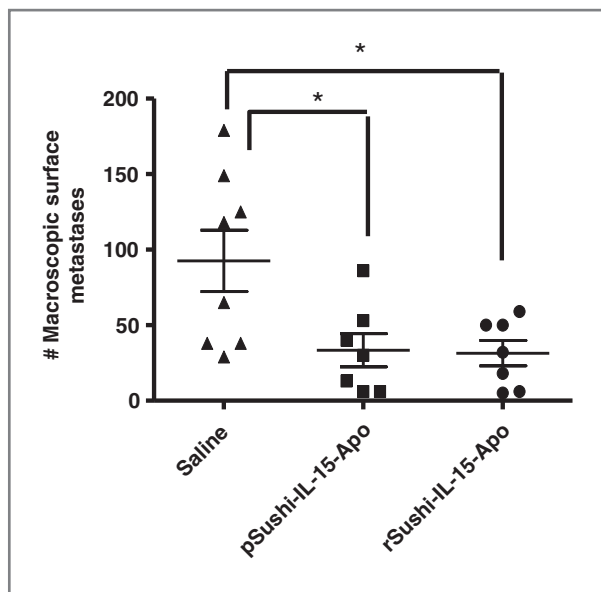

Figure 7. Immunotherapeutic effects of the rSushi-IL-15-Apo fusion protein on B16OVA lung metastasis. C57Bl/6 mice were injected intravenously with 5×10^5 B16OVA cells on day 0 and given hydrodynamic gene transfer of pSushi-IL-15-Apo on day +1 or 50 μ g of the corresponding recombinant protein intravenously also on day +1. Lungs were inspected and the number of metastases recorded on day +14. Statistical comparisons were made by one-way ANOVA with Bonferroni corrections.

IL-15 as a single agent (NCT01385423, NCT01369888, and NCT01021059, NCT01572493) following its excellent safety profile in non-human primates (25). Nonetheless more bioac-

tive and stable forms of IL-15 should follow in clinical development to make the most of this therapeutic tool.

Disclosure of Potential Conflicts of Interest

I. Melero and J. Prieto are consultant/advisory board members of DIGNA-BIOTECH. No potential conflicts of interest were disclosed by the other authors.

Authors' Contributions

Conception and design: J. Fioravanti, J. Prieto, P. Berraondo, I. Melero
Development of methodology: M.C. Ochoa, J. Fioravanti, I. Rodriguez, S. Hervas-Stubbs, A. Azpilikueta, G. Mazzolini, A. Gurrpide, J. Pardo, I. Melero
Acquisition of data (provided animals, acquired and managed patients, provided facilities, etc.): A. Azpilikueta, A. Gurrpide, J. Pardo
Analysis and interpretation of data (e.g., statistical analysis, biostatistics, computational analysis): M.C. Ochoa, J. Fioravanti, A. Gurrpide, P. Berraondo
Writing, review, and/or revision of the manuscript: M.C. Ochoa, J. Fioravanti, G. Mazzolini, A. Gurrpide, J. Pardo, P. Berraondo, I. Melero
Administrative, technical, or material support (i.e., reporting or organizing data, constructing databases): A. Azpilikueta, I. Melero
Study supervision: A. Gurrpide, J. Prieto, P. Berraondo, I. Melero

Grant Support

This study was financially supported by Ministerio de Educación y Ciencia/Ministerio de Ciencia e Innovación (SAF2005-03131, SAF2008-03294 SAF2011-22831, and SAF2011-25390), Departamento de Salud del Gobierno de Navarra, European Commission 7th Framework Program (ENCITE) SUDOE-IMMUNONET, Fundacion Mutua Madrileña, Fondo de Investigación Sanitaria (FIS P110/00264), and "UTE for project FIMA." M.C. Ochoa receives a Sara Borrel fellowship from FIS and S. Hervas-Stubbs receives a Ramon y Cajal contract from Ministerio de Educación y Ciencia. P. Berraondo receives a Miguel Servet contract from Spanish Fondo de Investigación Sanitaria.

The costs of publication of this article were defrayed in part by the payment of page charges. This article must therefore be hereby marked advertisement in accordance with 18 U.S.C. Section 1734 solely to indicate this fact.

Received July 5, 2012; revised October 15, 2012; accepted November 3, 2012; published OnlineFirst November 13, 2012.

References

- Yu P, Steel JC, Zhang M, Morris JC, Waldmann TA. Simultaneous blockade of multiple immune system inhibitory checkpoints enhances antitumor activity mediated by interleukin-15 in a murine metastatic colon carcinoma model. *Clin Cancer Res* 2010;16:6019-28.
- Dubois S, Patel HJ, Zhang M, Waldmann TA, Muller JR. Preassociation of IL-15 with IL-15R alpha-IgG1-Fc enhances its activity on proliferation of NK and CD8+/CD44 high T cells and its antitumor action. *J Immunol* 2008;180:2099-106.
- de Jong JL, Farnier NL, Sondel PM. Distinctions in lymphocyte responses to IL-2 and IL-15 reflect differential ligand binding interactions with the IL-2Rbeta chain and suggest differential roles for the IL-2Ralpha and IL-15Ralpha subunits. *Cytokine* 1998;10:920-30.
- Weiss JM, Back TC, Scarzello AJ, Subleski JJ, Hall VL, Stauffer JK, et al. Successful immunotherapy with IL-2/anti-CD40 induces the chemokine-mediated mitigation of an immunosuppressive tumor microenvironment. *Proc Natl Acad Sci U S A* 2009;106:19455-60.
- Kukita T, Arima N, Matsushita K, Arimura K, Ohtsubo H, Sakaki Y, et al. Autocrine and/or paracrine growth of adult T-cell leukaemia tumour cells by interleukin 15. *Br J Haematol* 2002;119:467-74.
- Yu YL, Wei CW, Chen YL, Chen MH, Yiang GT. Immunotherapy of breast cancer by single delivery with rAAV2-mediated interleukin-15 expression. *Int J Oncol* 2010;36:365-70.
- Vera M, Razquin N, Prieto J, Melero I, Fortes P, Gonzalez-Aseguinolaza G. Intratumoral injection of dendritic cells transduced by an SV40-based vector expressing interleukin-15 induces curative immunity mediated by CD8+ T lymphocytes and NK cells. *Mol Ther* 2005;12:950-9.
- Kaspar M, Trachsel E, Neri D. The antibody-mediated targeted delivery of interleukin-15 and GM-CSF to the tumor neovasculature inhibits tumor growth and metastasis. *Cancer Res* 2007;67:4940-8.
- Mortier E, Quemener A, Vusio P, Lorenzen I, Boublik Y, Grotzinger J, et al. Soluble interleukin-15 receptor alpha (IL-15R alpha)-sushi as a selective and potent agonist of IL-15 action through IL-15R beta/gamma. Hyperagonist IL-15 x IL-15R alpha fusion proteins. *J Biol Chem* 2006;281:1612-9.
- Bessard A, Sole V, Bouchaud G, Quemener A, Jacques Y. High antitumor activity of RL1, an interleukin-15 (IL-15)-IL-15 receptor alpha fusion protein, in metastatic melanoma and colorectal cancer. *Mol Cancer Ther* 2009;8:2736-45.
- Francis GA. The complexity of HDL. *Biochim Biophys Acta* 2010;1801:1286-93.
- Fioravanti J, Gonzalez I, Medina-Echeverez J, Larrea E, Ardaiz N, Gonzalez-Aseguinolaza G, et al. Anchoring interferon alpha to apolipoprotein A-I reduces hematological toxicity while enhancing immunostimulatory properties. *Hepatology* 2011;53:1864-73.
- Pardo J, Balkow S, Anel A, Simon MM. Granzymes are essential for natural killer cell-mediated and perfacilitated tumor control. *Eur J Immunol* 2002;32:2881-7.
- Dobrzanski MJ, Reome JB, Dutton RW. Therapeutic effects of tumor-reactive type 1 and type 2 CD8+ T cell subpopulations in established pulmonary metastases. *J Immunol* 1999;162:6671-80.
- Melero I, Duarte M, Ruiz J, Sangro B, Galofre J, Mazzolini G, et al. Intratumoral injection of bone-marrow derived dendritic cells engineered to produce interleukin-12 induces complete regression of

- established murine transplantable colon adenocarcinomas. *Gene Ther* 1999;6:1779–84.
16. Soman G, Yang X, Jiang H, Giardina S, Vyas V, Mitra G, et al. MTS dye based colorimetric CTLL-2 cell proliferation assay for product release and stability monitoring of interleukin-15: assay qualification, standardization and statistical analysis. *J Immunol Methods* 2009;348:83–94.
 17. Hervas-Stubbs S, Mancheno U, Riezu-Boj JI, Larraga A, Ochoa MC, Alignani D, et al. CD8 T cell priming in the presence of IFN- α renders CTLs with improved responsiveness to homeostatic cytokines and recall antigens: important traits for adoptive T cell therapy. *J Immunol* 2012;189:3299–310.
 18. He Y, Pimenov AA, Nayak JV, Plowey J, Falo LD Jr, Huang L. Intravenous injection of naked DNA encoding secreted *flt3* ligand dramatically increases the number of dendritic cells and natural killer cells *in vivo*. *Hum Gene Ther* 2000;11:547–54.
 19. Lodolce JP, Burkett PR, Boone DL, Chien M, Ma A. T cell-independent interleukin 15 α signals are required for bystander proliferation. *J Exp Med* 2001;194:1187–94.
 20. Huntington ND, Alves NL, Legrand N, Lim A, Strick-Marchand H, Mention JJ, et al. IL-15 transpresentation promotes both human T-cell reconstitution and T-cell-dependent antibody responses *in vivo*. *Proc Natl Acad Sci U S A* 2011;108:6217–22.
 21. Fehniger TA, Suzuki K, Ponnappan A, VanDeusen JB, Cooper MA, Florea SM, et al. Fatal leukemia in interleukin 15 transgenic mice follows early expansions in natural killer and memory phenotype CD8+ T cells. *J Exp Med* 2001;193:219–31.
 22. Marks-Konczalik J, Dubois S, Losi JM, Sabzevari H, Yamada N, Feigenbaum L, et al. IL-2-induced activation-induced cell death is inhibited in IL-15 transgenic mice. *Proc Natl Acad Sci U S A* 2000;97:11445–50.
 23. Su F, Kozak KR, Imaizumi S, Gao F, Amneus MW, Grijalva V, et al. Apolipoprotein A-I (apoA-I) and apoA-I mimetic peptides inhibit tumor development in a mouse model of ovarian cancer. *Proc Natl Acad Sci U S A* 2010;107:19997–20002.
 24. Cheever MA. Twelve immunotherapy drugs that could cure cancers. *Immunol Rev* 2008;222:357–68.
 25. Waldmann TA, Lugli E, Roederer M, Perera LP, Smedley JV, Macallister RP, et al. Safety (toxicity), pharmacokinetics, immunogenicity, and impact on elements of the normal immune system of recombinant human IL-15 in *Rhesus macaques*. *Blood* 2011;117:4787–95.