



Aalborg Universitet

AALBORG UNIVERSITY
DENMARK

Model Based Fault Diagnosis in a Centrifugal Pump Application using Structural Analysis

Kallesøe, C. S.; Izadi-Zamanabadi, Roozbeh; Rasmussen, Henrik; Cocquempot, V.

Publication date:
2004

Document Version
Også kaldet Forlagets PDF

[Link to publication from Aalborg University](#)

Citation for published version (APA):

Kallesøe, C. S., Izadi-Zamanabadi, R., Rasmussen, H., & Cocquempot, V. (2004). Model Based Fault Diagnosis in a Centrifugal Pump Application using Structural Analysis.

General rights

Copyright and moral rights for the publications made accessible in the public portal are retained by the authors and/or other copyright owners and it is a condition of accessing publications that users recognise and abide by the legal requirements associated with these rights.

- ? Users may download and print one copy of any publication from the public portal for the purpose of private study or research.
- ? You may not further distribute the material or use it for any profit-making activity or commercial gain
- ? You may freely distribute the URL identifying the publication in the public portal ?

Take down policy

If you believe that this document breaches copyright please contact us at vbn@aub.aau.dk providing details, and we will remove access to the work immediately and investigate your claim.

Model Based Fault Diagnosis in a Centrifugal Pump Application using Structural Analysis

Carsten Skovmose Kallesøe
Grundfos Management A/S
Poul Due Jensens Vej 7
DK-8850 Bjerringbro
Denmark
ckallesoe@grundfos.com

Roozbeh Izadi-Zamanabadi & Henrik Rasmussen
Dept. of Control Engineering, Aalborg University
Fredriks Bajers Vej 7
DK-9200 Aalborg Ø
Denmark
{hr,riz}@control.auc.dk

Vincent Cocquempot
USTL - LAIL
Bat P2 Cité Scientifique
59655 Villeneuve d'Ascq Cedex
France
cocquempot@univ-lille1.fr

Abstract—A model based approach for fault detection and isolation in a centrifugal pump is proposed in this paper. The fault detection algorithm is derived using a combination of structural analysis, Analytical Redundant Relations (ARR) and observer designs. Structural considerations on the system are used to indentify four subsystems each sensitive to a subset of the faults under consideration. Either an ARR or a residual observer is designed for each of the four subsystems. The four obtained residuals are then used for fault isolation. The applicability of the algorithm is illustrated by applying it to an industrial benchmark. The benchmark tests have shown that the algorithm is capable of detection and isolation of five different faults in the mechanical and hydraulic parts of the pump.

I. INTRODUCTION

Centrifugal pumps are used in a variety of different applications. This could for example be in a water supply application where submersible pumps are used in water wells to lift water to the surface. Some of these installations are crucial for a larger system to work. Failures can lead to substantial economic losses and can affect the life comfort of many people when they occur. Therefore detection of faults, if possible in an early stage, and isolation of their causes are of great interest. Especially fault detection, which can be used for predictive maintenance, could save money and increase reliability of the application in which the pump is placed.

Different approaches have been used for fault detection in centrifugal pumps. In [7], [8] current spectrum signatures are used for detection of different faults like blockage, cavitation, and damaged impeller. In [9], [4] model based approaches are used. In [9] the nonlinear system is modelled by a set of fuzzy functions and in [4] a linearized version of the system model is used. Both of these consider both detection and isolation of faults in systems containing centrifugal pumps.

In this work a model-based approach is used for residual generation. The presented approach utilizes a nonlinear model of the submersible application. This makes the obtained algorithm independent of the operating point in which the pump is running. The algorithm utilizes torque, speed, pressure and flow signals to generate the residuals.

The algorithm is derived by first identifying four subsystem using structural analysis [3], [6]. From the structural model of the system it is seen that all of these subsystems includes different subsets of the faults considered in this work. Therefore they can be used for fault isolation. Three of these sets contain differential constraints [3] meaning that derivatives of the output are necessary if an Analytical Redundancy Relation (ARR) is derived. To overcome this problem residual observers are designed in these three cases. An overview of the contribution to observer design for residual generation can be found in [5]. In the single case where the subsystem does not contain differential constraints an ARR is used for residual generation.

As a model-based approach is used in this work, this paper starts by presenting the model of a submersible pump application in section III. The fault detection algorithm is considered in section IV. This includes identifying subsystems using structural analysis, designing the residual observers, and the ARR. Section V presents test results obtained on an industrial benchmark, which has been particularly developed for this purpose. Finally concluding remarks end the paper.

II. NOMENCLATURE

The parameters in the model presented in section III are decribed in the following.

J	Moment of inertia of the rotor and the impeller.
B	Linear friction.
K_j	Derived moment of inertia of the water in the system.
K_p	Pressure losses inside the pipeline.
K_v	Pressure losses inside the valve.
a_{hi}	Parameters in the pressure model of the pump, $i \in \{1, 2, 3\}$.
a_{ti}	Parameters in the torque model of the pump, $i \in \{1, 2, 3\}$.
g	Gravity constant.
ρ	The density of the liquid in the system.

III. THE SUBMERSIBLE PUMP APPLICATION

This section presents the mathematical model of a submersible pump application including faults and distur-

bances. The submersible pump application is depicted in figure 1.

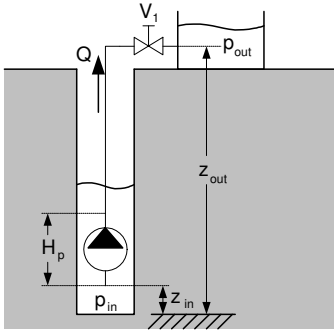

Fig. 1. A sketch of a submersible pump application including a well, a pipe, a valve, and a centrifugal pump.

This figure illustrates a pump placed at the bottom of a well pumping water to the surface. The variables assumed known in the system are the shaft torque, the shaft speed, the pressure produced by the pump, and the volume flow through the pump. In figure 1 the pressure is labeled H_p and the volume flow is labeled Q . Moreover the water in the well is lifted from level z_{in} to z_{out} and the volume flow Q can be controlled by a valve V_1 at the top of the well. The inlet and outlet pressure of the pipe system are labeled respectively p_{in} and p_{out} .

A. Model Without Faults

The equations describing the submersible pump system under no fault conditions are given by the following set of relations,

$$\begin{aligned}
 c_1 : J \frac{d\omega_r}{dt} &= T_e - B\omega_r - T_p \\
 c_2 : K_J \frac{dQ}{dt} &= H_p - p_l \\
 c_3 : H_p &= -a_{h2}Q^2 + a_{h1}Q\omega_r + a_{h0}\omega_r^2 \\
 c_4 : T_p &= -a_{t2}Q^2 + a_{t1}Q\omega_r + a_{t0}\omega_r^2 \\
 c_5 : y_1 &= H_p \\
 c_6 : y_2 &= \omega_r \\
 c_7 : y_3 &= Q
 \end{aligned} \quad (1)$$

Relation c_1 and c_2 respectively describe the dynamics of the mechanical and the hydraulic system. In these ω_r is the shaft speed of the pump and Q is the volume flow through the pump. The relation c_4 models the pressure delivered by the pump H_p and the relation c_5 models the load torque on the shaft generated by the pump T_p . Finally the relations c_5 to c_7 model the sensor system of the application. Here y_1 is the differential pressure measurement, y_2 is the speed measurement and y_3 is the flow measurement. Beside the measurements the input torque T_e of the system is assumed known.

In the model presented in (1) the pressure p_l is the load pressure of the well and is given by,

$$p_l = (p_{out} - p_{in} + \rho g(z_{out} - z_{in})) - (K_v + K_p)Q^2$$

This pressure is derived from the depth of the well denoted by $z_{out} - z_{in}$, the inlet and outlet pressure of the pipeline system, and the flow dependent pressure loss in the pipe and valve. All of these are assumed unknown in the following, meaning that the pressure p_l must be assumed unknown in the development of the detection algorithm.

The model presented in (1) is only valid for positive speed and positive flow, since the valve model and the relations c_4 and c_5 are only valid for positive flow and speed i.e. $\omega_r, Q \in R_+$.

B. Model Including Disturbances and Faults

Five faults are considered in this work, these are,

- 1) clogging inside the pump,
- 2) increased friction due to either rub impact or bearing faults,
- 3) increased leakage flow,
- 4) performance degradation due to cavitation,
- 5) dry running.

The first three faults are internal faults caused by respectively impurities in the liquid and wear. The 4th fault, cavitation, is caused by too low inlet pressure, meaning that the fault is external. However, in this work it is treated as an internal fault. Finally, the last fault, dry running, is a phenomenon caused by faults in the surrounding system, hence it is an external fault and is treated as so. Even though it is not a fault in the pump, this fault is important to detect as sealing rings and bearings will be destroyed when the pump is running without water for only a few seconds.

The mentioned faults all affect the hydraulic part of the pump. The performance of the hydraulic part of the pump is in this model described by relation c_4 , c_5 and c_7 in (1). These relations respectively describe the pressure and the torque produced by the pump and the flow measurement. Introducing the faults, these relations become,

$$\begin{aligned}
 c_3 : H_p &= f_H(Q, \omega_r) - K_f Q^2 - C_{ch} f_c - C_{dh} f_d \\
 c_4 : T_p &= f_T(Q, \omega_r) + \Delta B \omega_r - C_{ct} f_c - C_{dt} f_d \\
 c_7 : y_3 &= Q - K_l \sqrt{H_p}
 \end{aligned}$$

where $f_H(Q, \omega_r)$ and $f_T(Q, \omega_r)$ are given by,

$$\begin{aligned}
 f_H(Q, \omega_r) &= -a_{h2}Q^2 + a_{h1}Q\omega_r + a_{h0}\omega_r^2 \\
 f_T(Q, \omega_r) &= -a_{t2}Q^2 + a_{t1}Q\omega_r + a_{t0}\omega_r^2
 \end{aligned} \quad (2)$$

In this fault model $K_f \in R_+$ represents clogging, $\Delta B \in R_+$ represents rub impact, $K_l \in R_+$ represents increased leakage flow, $f_c \in R_+$ represents cavitation and $f_d \in R_+$ represents dry running. The first three signals model the faults accurately, while the last two terms are linear approximations.

IV. FAULT DETECTION AND ISOLATION

In this section the model presented in the previous section is used to develop a fault detection and isolation algorithm. To do so structural analysis is used to identify over-determined subsystems containing information about different subsets of the faults. When the subsystems are

identified the residuals are obtained using respectively an ARR and three simple observers. The simplicity of these observers is due to the utilization of structural analysis to obtain simple submodels for use in the observer design.

A. Structure Analysis

The system is described by the relations shown in (1). These relations can be represented by the graph shown in table I, where the constraints c_1, \dots, c_7 are given by (1) and the constraints d_1 and d_2 are differential constraints, as defined in [3], meaning that $\frac{dx}{dt} = \dot{x}$ in this context.

Using the definitions and procedures described in [6] and [3] four over-determined subsystems are identified. These are,

$$\begin{aligned}\mathcal{F}_1 &= \{c_1, c_4, d_1, c_5, c_7\} \\ \mathcal{F}_2 &= \{c_3, c_5, c_6, c_7\} \\ \mathcal{F}_3 &= \{c_1, c_3, c_4, d_1, c_5, c_6\} \\ \mathcal{F}_4 &= \{c_1, c_3, c_4, d_1, c_6, c_7\}\end{aligned}$$

From these four over-determined subsystems, or matchings, it is seen that the constraint c_2 is not used in any of the matchings. This constraint describes the application in which the pump is placed. When this constraint is not used in a matching it means that the matching is independent of the application model. Therefore the four above matchings can be used for fault detection and isolation in centrifugal pumps placed in any possible application.

Looking at the column to the right in table I the faults affecting each of the over-determined subsystems \mathcal{F}_i can be identified. The connection between the faults and the over-determined subsystems is shown below,

$$\begin{aligned}\mathcal{F}_1 &: \{K_L, \Delta B, f_c, f_d\} \\ \mathcal{F}_2 &: \{K_f, K_L, f_c, f_d\} \\ \mathcal{F}_3 &: \{K_f, \Delta B, f_c, f_d\} \\ \mathcal{F}_4 &: \{K_f, K_L, \Delta B, f_c, f_d\}\end{aligned}\quad (3)$$

This connection is a necessary, but not sufficient, condition for a given \mathcal{F}_i to be sensitive to a given fault. These connections show that the faults f_c and f_d are indistinguishable from a structural point of view, meaning that isolation of these faults is impossible for almost all set of parameters in (1).

From the connection between faults and relations presented in (3) it is seen that no additional information is added using \mathcal{F}_4 . Therefore the set,

$$\{\mathcal{F}_1, \mathcal{F}_2, \mathcal{F}_3\}$$

contains the obtainable information about the faults in the system. The last relation \mathcal{F}_4 could be used for validation in a robust fault detection scheme.

B. The Residual Generators

Looking at the relations forming the matching \mathcal{F}_2 it is seen that no differential constraints are included in this.

Therefore an ARR obtained from this matching does not include derivatives. The ARR is given by,

$$r_2 = -a_{h2}y_3^2 + a_{h1}y_1y_3 + a_{h0}y_1^2 - y_2 \quad (4)$$

It is also possible to obtain ARR's from the sets \mathcal{F}_1 , \mathcal{F}_3 and \mathcal{F}_4 , but as differential constraint is used in each of these matchings it is necessary to use derivatives of the output in these cases. To avoid this, three residual observers are developed in the following.

The three matchings \mathcal{F}_1 , \mathcal{F}_3 and \mathcal{F}_4 are all on a form given by definition 1,

Definition 1 A system on the form,

$$\begin{aligned}\dot{x} &= ax + f(x, z, u) + e_1(x, z)f_1 \\ y_1 &= h_1(x, z) + e_2(x, z)f_2 \\ y_2 &= h_2(x, z) + e_3(x, z)f_3\end{aligned}\quad (5)$$

is said to be on over-measured form. In (5) $x, y_1, y_2, u, z \in R^1$ and e_1, e_2 and e_3 are nonlinear functions of x and z .

Assumption 1 It is assumed that in the case where no sensor faults have occurred, i.e. $f_2 = f_3 = 0$, the output maps h_1 and h_2 in definition 1 can be solved for x and z locally. The solutions are given by the following expressions,

$$\begin{aligned}x &= g_1(y_1, y_2) \\ z &= g_2(y_1, y_2)\end{aligned}\quad (6)$$

The implicit function theorem [1] can for example be used to show that a solution exist locally. Using the above assumption the following lemma describes a residual observer for the system defined in definition 1.

Lemma 1 Under assumption 1 the following observer is a residual observer for systems described by definition 1,

$$\begin{aligned}\dot{\hat{x}} &= a\hat{x} + f(g_1(y_1, y_2), g_2(y_1, y_2), u) + k(g_1(y_1, y_2) - \hat{x}) \\ r &= q(g_1(y_1, y_2) - \hat{x})\end{aligned}\quad (7)$$

The residual observer is asymptotical stable if $a - k < 0$. The fault input to this observer is given by,

$$\begin{aligned}f_f &= (f(x, z) - f(x - \delta x_f, z - \delta z_f)) \\ &\quad + e_1(x, z)f_1 - k\delta x_f\end{aligned}$$

where f_f is a derived fault signal, which is strongly detectable. In the expression of f_f the signals δx_f and δz_f are given by,

$$\begin{aligned}\delta x_f &= g_1(y_1 - e_2(x, z)f_2, y_2 - e_3(x, z)f_3) - g_1(y_1, y_2) \\ \delta z_f &= g_2(y_1 - e_2(x, z)f_2, y_2 - e_3(x, z)f_3) - g_2(y_1, y_2)\end{aligned}$$

The proof of the lemma is given in appendix I.

Remark 1 The derived fault f_f is strongly detectable using this observer. This is not the case for the faults f_1, f_2 and f_3 , as the nonlinear expression of f_f can equal zero even though one of the faults f_1, f_2 or f_3 is different from zero.

TABLE I

THE STRUCTURAL MODEL OF THE CENTRIFUGAL PUMP. x DENOTES UNI-DIRECTIONAL RELATIONS AND 1 DENOTES BI-DIRECTIONAL RELATIONS. UNI-DIRECTIONAL MEANS THAT THE GIVEN VARIABLE IS NOT CALCULABLE FROM THE RELATION, SEE DEFINITIONS IN [6].

	Known				Unknown							Fault signals				
	y_1	y_2	y_3	T_e	p_l	\dot{Q}	$\dot{\omega}_r$	T_p	ω_r	H_p	Q	K_f	K_l	ΔB	f_c	f_d
c_2					1	1				1	1					
d_2						1					x					
d_1							1		x							
c_1				1			1	1	1							
c_4								1	1		1			1	1	1
c_3									1	1	1	1			1	1
c_5	1								1							
c_6		1								1						
c_7			1								1		1			

Remark 2 The observer described by lemma 1 is designed under the assumption that a perfect model exists, and that the measurements are not affected by noise. This is of course not fulfilled in a real life applications. To overcome this the gain k of the observer is chosen such that errors due to small model mismatches and noise will be suppressed.

The matchings \mathcal{F}_1 , \mathcal{F}_3 and \mathcal{F}_4 are all on the form defined in definition 1 and fulfill assumption 1. Therefore lemma 1 can be utilized for observer design for these three matchings. The dynamics of the matchings are in all three cases govern by the following differential equation,

$$J \frac{d\omega}{dt} = T_e - B\omega + a_{t2}Q^2 - a_{t1}\omega Q - a_{t0}\omega^2 \quad (8)$$

This equation is formed by using the constraints c_1 and c_4 in (1). Each of the matchings utilizes different subsets of the following set of output maps,

$$\begin{aligned} y_1 &= \omega \\ y_2 &= -a_{h2}Q^2 + a_{h1}\omega Q + a_{h0}\omega^2 \\ y_3 &= Q \end{aligned} \quad (9)$$

The output maps are formed by using respectively constraint c_5 to obtain the expression for y_1 , the constraints c_3 and c_6 to obtain the expression for y_2 , and finally the constraint c_7 to obtain the expression for y_3 . The constraints are all given in (1).

From (9) it is seen that each subset of the output maps, containing two elements, fulfills assumption 1. Therefore lemma 1 can be used to obtain residual observers for the matchings. The obtained observers are given by,

$$\mathcal{O}_1 : \begin{cases} J \frac{d\hat{\omega}}{dt} = -B\hat{\omega} - f_T(y_3, y_1) + T_e + \\ k_1 (y_1 - \hat{\omega}) \\ r_1 = q_1 (y_1 - \hat{\omega}) \end{cases} \quad (10)$$

$$\mathcal{O}_3 : \begin{cases} J \frac{d\hat{\omega}}{dt} = -B\hat{\omega} - f_T(g_3(y_1, y_2), y_1) + T_e + \\ k_3 (y_1 - \hat{\omega}) \\ r_3 = q_3 (y_1 - \hat{\omega}) \end{cases} \quad (11)$$

$$\mathcal{O}_4 : \begin{cases} J \frac{d\hat{\omega}}{dt} = -B\hat{\omega} - f_T(y_3, g_4(y_2, y_3)) + T_e + \\ k_4 (g_4(y_2, y_3) - \hat{\omega}) \\ r_4 = q_4 (g_4(y_2, y_3) - \hat{\omega}) \end{cases} \quad (12)$$

where k_i is designed according to lemma 1 and q_i is chosen such that the residuals have a reasonable value in the case of faults. The function f_T is given in (2) and the functions g_3 and g_4 are derived from the output maps in (9), and are given by,

$$\begin{aligned} g_3(y_1, y_2) &= \frac{a_{h1}y_1 + \sqrt{a_{h1}^2 y_1^2 - 4a_{h2}(y_2 - a_{h0}y_1^2)}}{2a_{h2}} \\ g_4(y_2, y_3) &= \frac{-a_{h1}y_3 + \sqrt{a_{h1}^2 y_3^2 + 4a_{h0}(y_2 + a_{h2}y_3^2)}}{2a_{h0}} \end{aligned}$$

These expressions are valid for $y_1, y_3 \in R_+$ when using the parameters of the pump used in the test described in the following section. Therefore the expressions are valid in the state space $\omega_r, Q \in R_+$, which is exactly the state space in which the model is valid, see section III-A.

V. TEST RESULTS

The detection algorithm, derived in the previous sections, is in this section tested on a Grundfos 1.5 (KW) CR5-10 pump. This pump placed in a tank system as depicted in figure 2. The measurements used in the detection algorithm

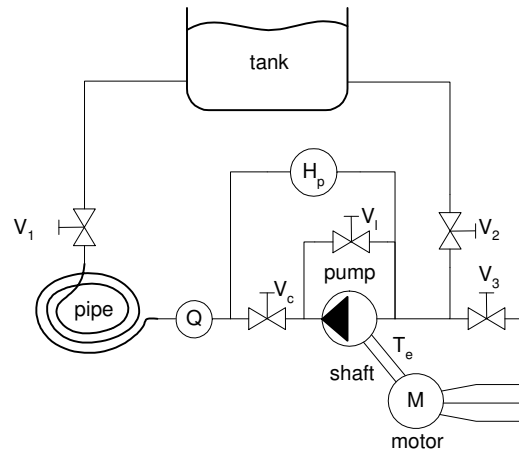

Fig. 2. Sketch of the test setup. The measurements are the shaft torque T_e , the differential pressure H_p delivered by the pump and the volume flow through the pump Q .

are the torque on the shaft T_e , the differential pressure H_p

delivered by the pump and the volume flow through the pump Q . The valve V_1 is used to model disturbances in the system. Clogging inside the pump is modelled by the valve V_c and dry running is modelled by closing V_2 and opening V_3 . Rub impact is modelled adding an extra force to the shaft and cavitation is modelled by closing valve V_2 gradually. Leakage flow is modelled by opening V_l .

Test results have shown that the sensitivity to the faults f_c and f_d of the observer \mathcal{O}_4 is very low. Infact it is so low that changes due to the faults are smaller than changes due to noise and parameter variations. Moreover in section IV-A it is shown that the obtainable fault information is included in the residual r_1 , r_2 , and r_3 . Therefore only these residuals are considered in the test presented in this section.

Since the tests are performed on a real system, noise is expected on the residuals. To overcome this problem a CUSUM algorithm [2] is used to detect changes in the mean of the residuals and thereby detect the faults. In the following, outputs of the CUSUM algorithms are denoted D_1 to D_3 , where D_1 is the decision signal of r_1 and so forth.

All test results are shown in figure 3. First robustness with respect to the operating point is tested. In this test both the position of the valve V_1 and the speed of the pump are changed during operation. During the test the valve is changed in three steps from medium to maximum opened. The speed of the pump is changed between 2380 and 2910 (rpm) each 2 (sec) during the test. The result of this test is shown in figure 3(a), where r_1 to r_3 is shown in the top figure and the decision signals D_1 to D_3 in the bottom figure. The test shows that the three residual generators are robust with respect to the tested operating points, but also that there are some dependency to the operating point, see top figure of figure 3(a), This is partly due to problems with the flow sensor at zero flow and partly due to dependency between the parameters and the operating point.

Figure 3(b) to 3(f) shows test results concerning isolability of the five faults of interest in this work. All these tests are performed with V_1 half opened and an angular speed of approximately 2650 (rpm). Comparing the five figures 3(e) and 3(f) it is seen that the faults are distinguishable except for cavitation and dry running. This was expected as the structural analysis in section IV-A already had foreseen this.

VI. CONCLUSION

The topic of this work is fault detection and isolation in a centrifugal pump placed in a submersible application. An algorithm is developed, which is capable of detection and isolation of the faults in a centrifugal pump. The proposed algorithm is independent of the application in which the pump is placed. This makes the algorithm robust and usable in a wide range of applications including the submersible application under consideration in this work.

Tests have shown that it is possible to distinguish between the four of the five faults under consideration with the three

chosen residuals. But it is also shown that the algorithm is sensitive to the operating point. This is partly due to dependency between the operating point and the parameters in the model and partly due to flow sensor problems. Even though there are some dependencies between the operating point and the performance of the algorithm, the algorithm still performs considerable better than algorithms build on a linearized model.

REFERENCES

- [1] Apostol, Tom M. *Mathematical Analysis, second edition*. Addison-Wesley Publishing Company, Inc., 1974.
- [2] Basseville, Michele and Nikiforov, Igor V. *Detection of Abrupt Changes - Theory and Application*. www.irisa.fr/sigma2/kniga/, 1998.
- [3] Blanke, Mogens, Kinnaert, Michel, Lunze, Jan, and Starowiecki, Marcel. *Diagnosis and Fault-Tolerant Control*. Springer Verlag, 2003.
- [4] Dalton, Tracy, Patton, Ron J., and Chen, J. An application of eigenstructure assignment to robust residual design for fdi. *UKACC, CONTROL '96*, September 1996.
- [5] Frank, P. M. Garcia, E. Alcorta. Deterministic nonlinear observer-based approaches to fault diagnosis: A survey. *Control Eng. practice Vol. 5 No. 5*, 1997.
- [6] Izadi-Zamanabadi, Roozbeh. Structural analysis approach for fault diagnosis and disturbance decoupling. *Priprint, Elsevier Science*, 2001.
- [7] Kenull, T., Kosyna, G., and Thamsen, P. U. Diagnostics of submersible motor pumps by non-stationary signals in motorcurrent. *The 1997 ASME Fluids Engineering Division Summer Meeting, FEDSM'97*, 1997.
- [8] Perovic, S., Unsworth, P. J., and Higham, E. H. Fuzzy logic system to detect pump faults from motor current spectra. *IEEE, Thirty-Sixth IAS Annual Meeting, 2001*, 2001.
- [9] Wolfram, Armin, Fussel, Dominik, Brune, Torsten, and Isermann, Rolf. Component-based multi-model approach for fault detection and diagnosis of a centrifugal pump. *IEEE, ACC-2001*, 2001.

APPENDIX I

PROOF OF LEMMA 1

From assumption 1 the inverse of the output maps of the system in definition 1 exists, meaning the following function can be obtained,

$$\begin{aligned} x &= g_1(y_1, y_2) \\ z &= g_2(y_1, y_2) \end{aligned} \quad (13)$$

where it is assumed that the faults $f_2 = f_3 = 0$.

Choosing the observer dynamics as a copy of the dynamics of the system defined by definition 1, and using the the inverse of the output maps the observer becomes,

$$\dot{\hat{x}} = a\hat{x} + f(g_1(y_1, y_2), g_2(y_1, y_2), u) + k(g_1(y_1, y_2) - \hat{x}) \quad (14)$$

when it is assumed that the fault $f_1 = 0$. Using the expression for the system the error equation of the observer becomes,

$$\begin{aligned} \dot{e} &= (ax + f(x, z, u)) - (a\hat{x} + f(x, z, u) + k(x - \hat{x})) \\ \dot{e} &= (a - k)e \end{aligned} \quad (15)$$

where (13) is used in the observer expression (14), meaning that $g_1(y_1, y_2) = x$ and $g_2(y_1, y_2) = z$. Equation (15) shows that the error dynamic of the observer is asymptotical stable if $a - k < 0$.

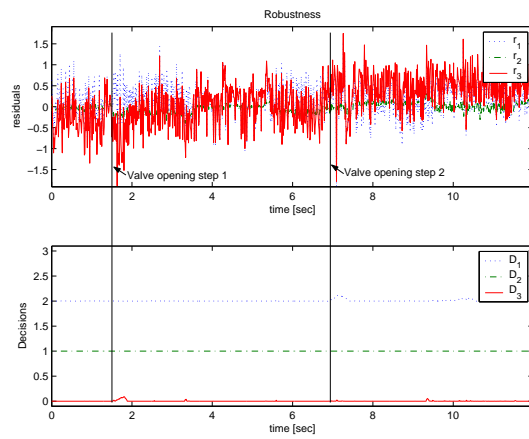

(a) Robustness test.

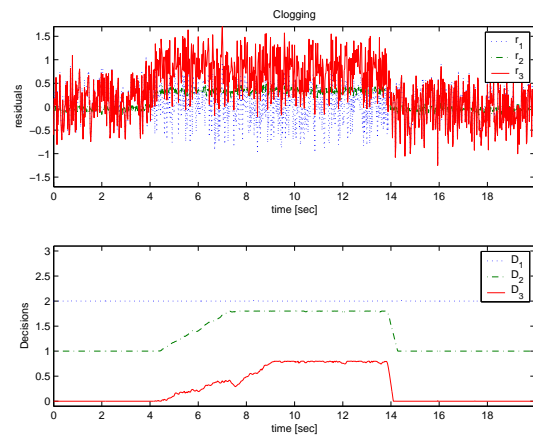

(b) Detection of the fault K_f clogging.

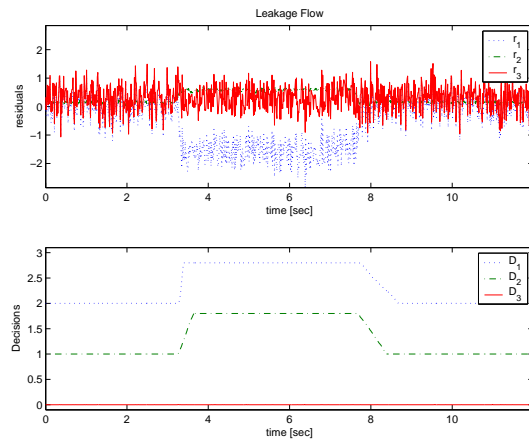

(c) Detection of the fault K_l leakage flow.

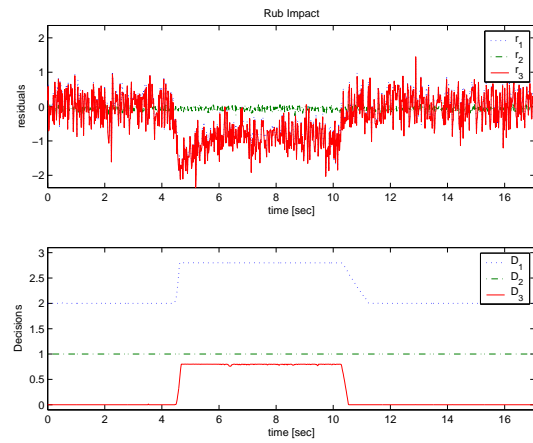

(d) Detection of the fault ΔB rub impact.

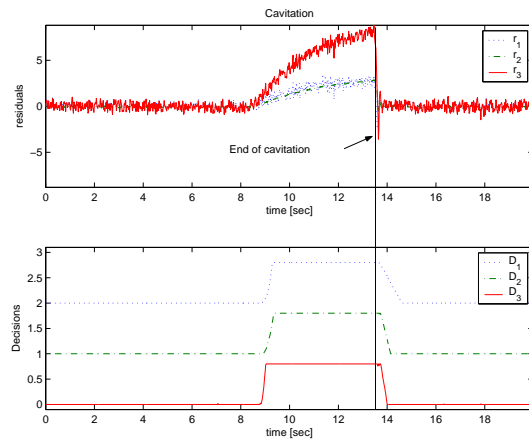

(e) Detection of the fault f_c cavitation.

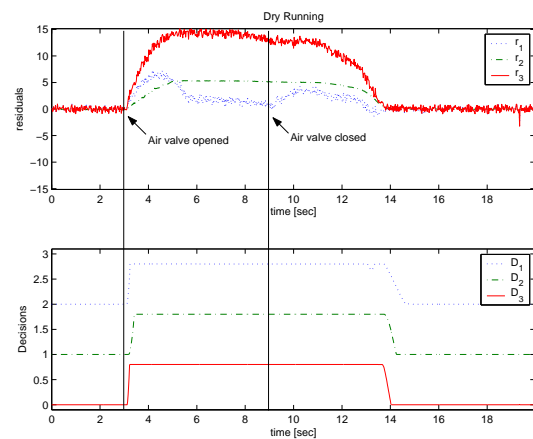

(f) Detection of the fault f_d dry running.

Fig. 3. Test results from test of the developed algorithms on the test setup. The top figures shows the obtained residuals and the bottom figures shows decision signals obtained from CUSUM algorithms.

The expression of the derived fault signal f_f is obtained in the following by introducing the fault signals in the error equation of the observer. Before this can be done, an expression of the fault when mapped through the g_1 and g_2 must be obtained. First the signals y_{1f} and y_{2f} are defined as,

$$\begin{aligned} y_{1f} &= y_1 - e_2(x, z)f_2 = h_1(x, z) \\ y_{2f} &= y_2 - e_3(x, z)f_3 = h_2(x, z) \end{aligned}$$

From these expression it is seen that the signals y_{1f} and y_{2f} must be used in the maps g_1 and g_2 to obtain the correct value of x and z , e.i.

$$\begin{aligned} x &= g_1(y_{1f}, y_{2f}) \\ z &= g_2(y_{1f}, y_{2f}) \end{aligned}$$

Then δx_f and x_f is defined as,

$$\begin{aligned} \delta x_f &= x - x_f \\ \delta x_f &= g_1(y_{1f}, y_{2f}) - g_1(y_1, y_2) \end{aligned}$$

and δz_f and z_f is defined likewise. Using these signals the error equation, including the faults, becomes,

$$\begin{aligned} \dot{e} &= ae + f(x, z, u) - f(x_f, z_f, u) + e_1(x, z)f_1 \\ &\quad - k(x_f - \hat{x}) \\ \dot{e} &= (a - k)e + (f(x, z, u) - f(x - \delta x_f, z - \delta z_f, u)) \\ &\quad + e_1(x, z)f_1 - k\delta x_f \end{aligned} \quad (16)$$

From this expression the following nonlinear expression of the fault can be identified,

$$\begin{aligned} f_f &= (f(x, z, u) - f(x + \delta x_f, z + \delta z_f, u)) \\ &\quad + e_1(x, z)f_1 - k\delta x_f \end{aligned}$$

Including this derived fault signal into the error equation in (16) it becomes,

$$\begin{aligned} \dot{e} &= (a - k)e + f_f \\ r &= qe \end{aligned}$$

From this expression it is seen that the derived fault signal f_f is strongly detectable. This is not the case for the faults f_1 , f_2 or f_3 due to the nonlinearities of the expression f_f making it possible that $f_f = 0$ even though one of the faults f_1 , f_2 or f_3 is different from zero.