

# Selection of Open or Closed boundaries in a Cellular Automata Model for Heterogeneous Non-Lane Based Traffic

Mohit Kumar Singh, K Ramachandra Rao

Abstract:

Cellular automata (CA) simulation models developed for traffic are either closed or open boundary type. The selection and difference of boundaries has been studied extensively for ideal and single-lane-homogeneous traffic conditions. However, the effect of these on multi-lane-heterogeneous traffic still needs attention because most of the traffic observed in many parts of the world is not single-lane-homogeneous traffic. It is evident from multiple studies that open and closed boundaries affect the simulation results. Moreover, these require different inputs for simulation. This study attempts to evaluate the difference in the results of open and closed boundary simulations in heterogeneous non-lane-based traffic. The methodology discussed in this study is relatable to the field conditions. The present study includes some of the common but often ignored features in the model such as seepage of small sized vehicles. Further, this study also includes some of the previously unnoticed features while modelling the non-lane-based traffic at intersections. The modelling of open boundaries simulation can be better and easy in most of the situations compared to the closed boundaries. Closed boundary simulation results for flow-density curve show a smooth trend, whereas open boundary simulation results are scattered as observed in the field. This study further concludes that the size of the vehicle does not change the fundamental diagrams except when other characteristics such as seepage, lane change and different maximum speeds for different modes are considered. The study used field observed influence zone of intersections (IZI) to decide the dimension of intersection in the simulation model.

**Keywords:** Cellular Automata, Traffic Simulation, Boundaries, Open Boundary, Closed Boundary, Heterogeneous Traffic

**Table 1 Symbols used in present study**

Symbols	Meaning
D	Desired density
t	t <sup>th</sup> time step
d <sub>t</sub>	Density of vehicle in t <sup>th</sup> time step
N	Number of vehicles
h	Headway
p	Randomization probability
p <sub>bl</sub>	Brake light randomization probability
p <sub>0</sub>	Randomization probability when speed of vehicle is 0 at t <sup>th</sup> time step
v <sub>n</sub> <sup>t</sup>	Speed of nth vehicle at some time 't'
t <sub>n</sub> <sup>h</sup>	Time headway
b <sub>n</sub> <sup>t</sup>	Brake light status (0 or 1) of n <sup>th</sup> vehicles at same time 't'
v <sub>n</sub> <sup>a</sup>	Acceleration of nth vehicle
v <sub>n</sub> <sup>max</sup>	Maximum speed of nth vehicle
g <sub>n</sub> <sup>cf</sup>	Front gap for n <sup>th</sup> vehicle
x <sub>n</sub> <sup>t</sup>	Position of n <sup>th</sup> vehicle at current time step t
g <sub>n</sub> <sup>si</sup>	Gap of nth vehicle from signal
I <sub>ap</sub> <sup>s</sup>	Location of signal
S	Signal status i.e. 0 (green signal) or 1 (red)
l <sub>n</sub>	Length of current vehicle
ap	Approach
IZI <sub>m</sub>	Zone of influence for mode m
x <sub>m,p',l2'</sub> <sup>t+1</sup>	Location of m <sup>th</sup> vehicle at t+1-time instance
p'	Road width wise location of vehicle
l <sub>2</sub> '	Road length wise location of vehicle

# 1 Introduction

The concept of boundaries is multidisciplinary including social science, biology, chemistry physics and engineering with similar definitions<sup>1</sup>. A lot of studies have been carried out in the past related with boundaries in other fields<sup>2-5</sup>. However, the application of these in a realistic transportation engineering simulation is missing from studies. Traffic simulation models are needed to assess the complex traffic conditions. These are simple, easy to use, less expensive, less time-consuming systems than any other available field alternative. Simulation models can help to analyse several cases quickly averting any expense, risk and interruptions which may be associated with field experimentation<sup>6</sup>. There are three ways to simulate traffic conditions: macroscopic, mesoscopic and microscopic simulations<sup>7</sup>. Depending upon the type of study and details required any one of the models is chosen. These simulation models work on some inputs such as traffic flow, maximum speeds, accelerations, decelerations, traffic compositions, facility type and boundary conditions etc. The present study evaluates boundary conditions in the cellular automata (CA) simulation models. Boundary conditions are the initialization of vehicles in the simulation models. The CA model can have two types of boundary conditions, closed and open. In the closed boundary system a fixed number of vehicles are generated, and only these vehicles simulate over the simulation time, no vehicle is added or removed from the system. Whereas in open boundary system vehicle are added as the time passes, and old vehicles get deleted at the end of the link. Many studies have been done to account single-lane homogeneous traffic conditions with different boundaries<sup>8-11</sup>. However, the prevailing traffic conditions in many parts of the world is neither single lane nor homogeneous. Hence, these studies have limited applicability in the field. Present study tries to model a realistic and feasible heterogeneous non-lane-based traffic conditions. Further, this study also includes the zone of influence of signalized intersection which affects the driver behaviour in terms of acceleration/deceleration. The difference in the simulation results were observed with different boundary conditions. Apart of open and closed boundary systems, the present study also discusses a third kind of boundary system named as partly open boundary. This system comprises of both closed and open boundary systems. Thus some new vehicles are added to the system, while some other vehicles return to the system at the end of the link.

## 1.1 Need for the study and scope

As discussed above, many studies have been done on homogeneous single lane traffic conditions. As the boundaries may affect the simulation results<sup>3</sup>, this paper gives an overview on the choice of open and closed boundaries for simulation, specifically for non-homogeneous, non-lane based traffic conditions. This study also includes the realistic, feasible and known but often ignored features such as seepage<sup>12,13</sup> and zone of influence<sup>13</sup>. This study considers fewer modes (bus, cars, two wheelers, motorized three wheelers) with multiple lanes at isolated signalized junction and at the mid-block. This study would be useful to decide the suitable boundary conditions for simulation of different facilities.

## 1.2 Structure of paper

First section of the paper gives about the introduction and scope of the study, followed by literature review in section 2. Section 3 explains the methodology, plan and issues related with the modelling of simulation model with open and closed boundaries. Section 4 discusses about the results. Conclusion and way forward are described in section 5.

# 2 Literature review and discussion:

Many studies have selected and simulated traffic with different boundary conditions. Most of these studies are based on single-lane, homogeneous traffic conditions which need significant modifications for further application to the

field related problems. Table 2 summarizes the studies based on open, closed and partly open boundaries for mid-block and intersections.

Table 2 Previous studies based on open/closed and partly open boundaries.

Boundary conditions	Intersections	Mid-block
Open boundary studies	14-23	2,10,17,24-29
Closed boundary studies	9,30-38	39-45
Partly open boundary simulations	No study found	

## 2.1 Simulation with periodic and open boundaries at the mid-block

Many of the CA models developed for mid-blocks thus far are based on periodic (closed) boundary conditions<sup>39-41,46</sup>. The movement of vehicles in the periodic boundaries is given as Figure 1a. Once the specific number of vehicles are imported in the system, they start moving based on specified CA rules, and it takes some time to adjust themselves according to surrounding this time is called warmup time<sup>42</sup>. The joining point of the end and beginning of a link is named as ‘X’ (Figure 1a). When the vehicles are at location ‘X’ they calculate the gaps ahead and move to the beginning of the link. This process continues for one complete simulation time in a closed system. If some facilities such as bus stop<sup>17,47</sup> or pedestrian crosswalk are simulated in a closed boundary then the gap between the consecutive facilities becomes constant and facilities are same all the time which may not be a realistic case. This could be avoided using open boundaries with a greater number of simulation time and making few bus stops at different locations. When open boundary simulation is done then vehicles after reaching at location ‘Y’ (Figure 1b) are deleted and new vehicles are generated at beginning of the road these steps are repeated till the simulation time is exhausted. Some studies have tried to simulate traffic in open boundaries and have suggested that open boundaries are closer to realistic traffic conditions.<sup>17,27-29</sup>

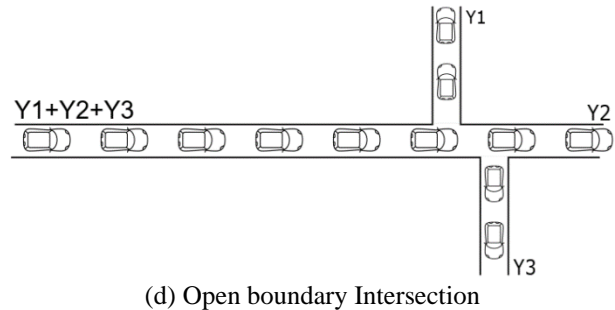
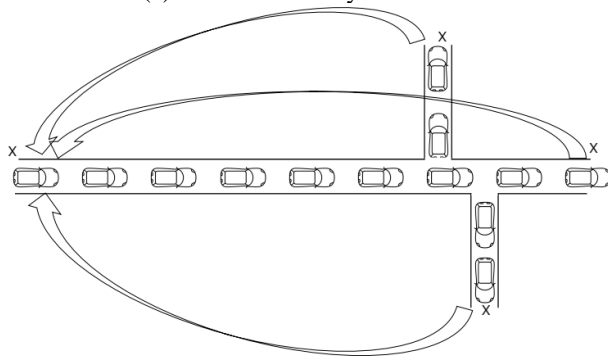
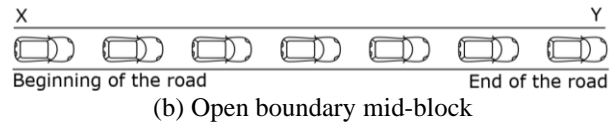
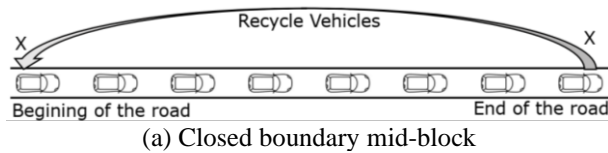

(c) Closed boundary Intersection

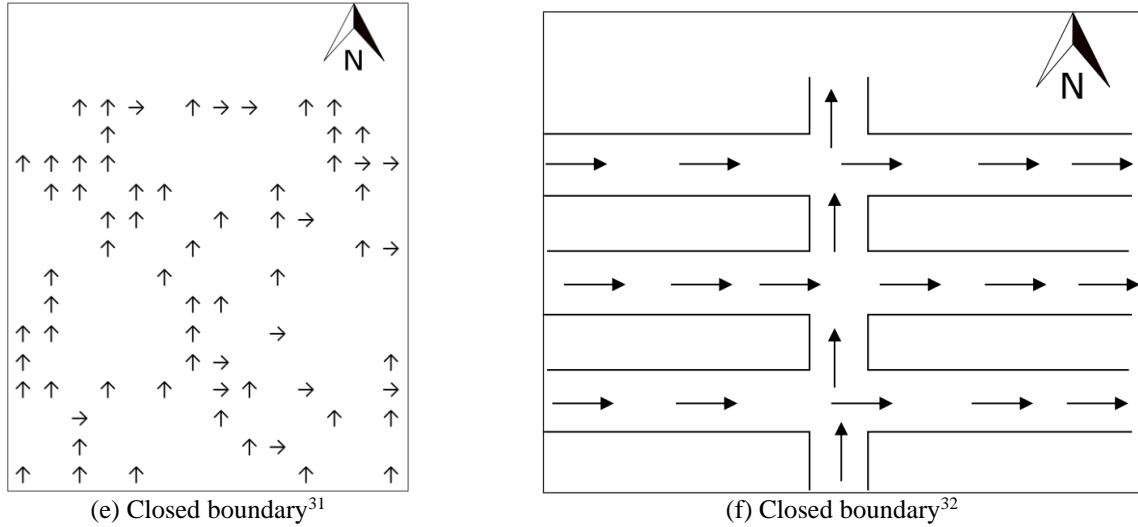

Figure 1 Possible methods to construct open and closed boundaries (a - d), examples of existing methods of closed boundary construction (e - f)

## 2.2 Simulation with open/closed boundary at Intersections

A closed boundary simulation can be represented as shown in Figure 1c. In this method vehicles moving in three different directions (left, right and straight) from an approach again come back to the beginning of same approach once they reach the end of this approach. Figure 1d shows the simulation in open boundaries. In open boundaries simulated vehicles are diverted from one approach to the respective approaches and when vehicles are at the end of the designated approach, they get deleted. Subsequently these vehicles are generated at the beginning of the approaches based on headway distribution observed in the field or with any other suitable method. Many existing studies simulate intersections using periodic<sup>9,30-38</sup> and open boundaries<sup>14-16,18-23,46</sup>. Raheja<sup>45</sup> presents an interesting analytical approach with Jackson queue model for traffic analysis at mid-blocks using periodic boundary. This approach however needs modification to address the problem at intersections where multiple vehicle types (different types of customers), lane changes and queue shorting when approaching the stop line (seepage or creep). Some authors<sup>32-34</sup> have simulated the junctions with closed boundaries in which vehicles move in two directions as shown in Figure 1e and 1f. For example vehicles in North-South approaches move only upwards (symbol  $\uparrow$  in Figure 1e and 1f) and vehicles in the East-West direction approach move from left to right (symbol  $\rightarrow$  in Figure 1e and 1f). Further, at the end of respective approach they again come back to the initial approach hence the density in the whole system is constant. Schroeder<sup>48</sup> proposed a method on how a series of scheduled tasks served with the help of open and closed boundaries. In the closed systems a fixed set of users ( $N$ ) are serviced endlessly whereas in open systems some new number of users arrive (irrespective of earlier served or not) with some arrival pattern. In Figure 2a there are some users surfing the web who have got the response and thinking they are called as  $N_{think}$  and some users ( $N_{system}$ ) who are either running or queued to run in system. This number 'N' ( $N = N_{system} + N_{think}$ ) is fixed in closed system. This phenomenon is analogous to closed boundary simulation of vehicles on a roadway using cellular automata where a fixed number of vehicles remain in the system and move, no other vehicle is added or removed from the system. Further, if the example of open boundaries is considered (Figure 2b) according to Schroeder<sup>48</sup> then users arrive for being served irrespective whether earlier users are served or not. Moreover, if old users are not served then new arrivals stand in the queue this case is similar to vehicles arrival at roadways, this behaviour is similar at any other road facility. Similar definition of closed and open boundaries are given in the study<sup>49</sup>. Schroeder suggested that neither open nor closed system can be purely realistic, and discovered an intermediate system called 'Partly Open System' (Figure 2c). In Partly open system some number of vehicles return to the system with probability 'p'. If we consider 'Partly Open System' in traffic engineering, then as no vehicle returns to the system again thus it becomes an open system. In the present study this approach is considered to achieve this task.

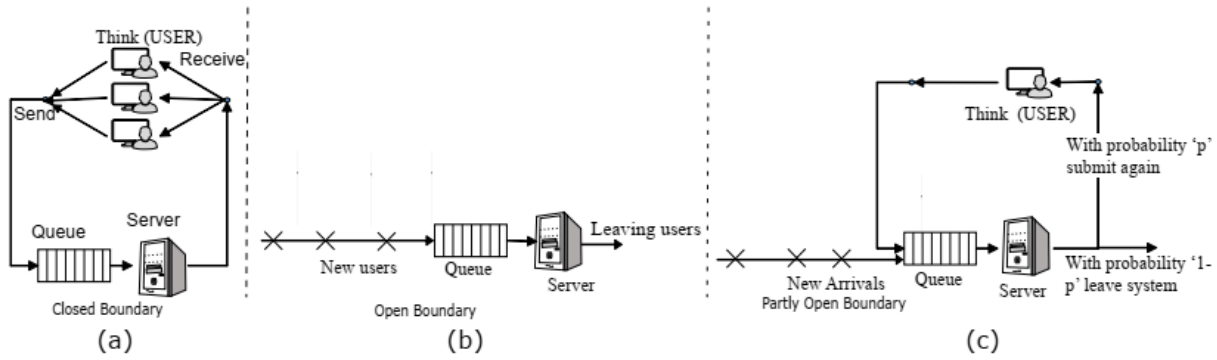

Figure 2 Open, Closed and Partly Open Boundaries <sup>48</sup>

Above discussion makes it clear that the traffic simulation is similar to a series of tasks to be completed (serving the vehicles at any traffic facility). If closed boundaries are used then the same drivers will be running on the approach over the simulation time which is unrealistic and the heterogeneity of the drivers is compromised. Open boundaries may be used to overcome this limitation and simulate a realistic and complicated traffic at signals or any other facility such as bus stops or pedestrian crosswalks. However, if only the mid-block simulation is desired then closed boundaries can be used. Figure 3a and 3b show the application of this methodology. It was also found that no partial open boundary system exists for traffic simulation (Table 2). The essentials of the rules for the modelling open and closed boundaries are presented in the next section.

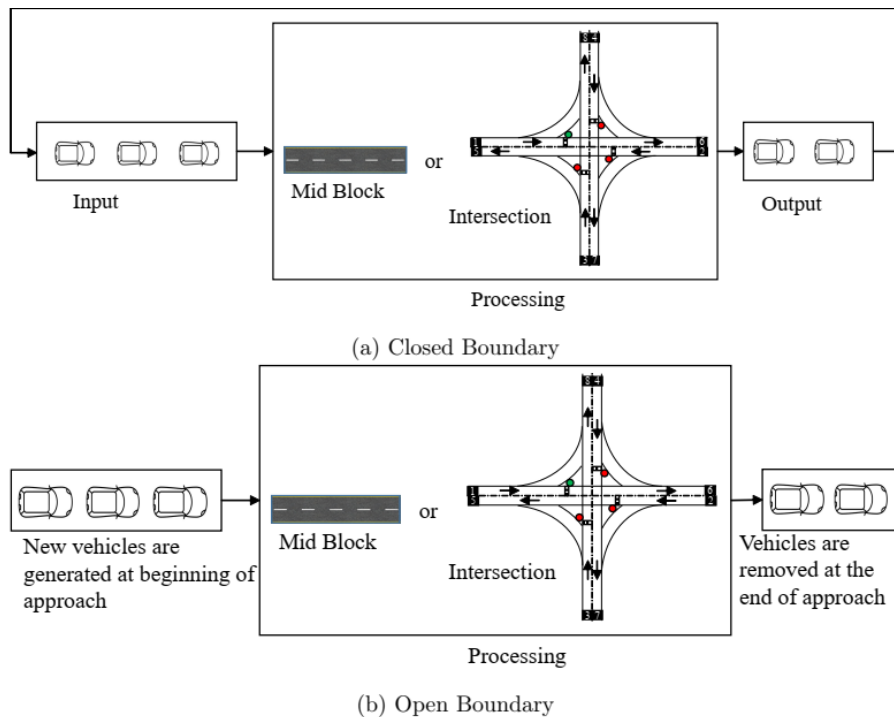

Figure 3 Open and closed boundaries at intersection and mid-block

### 3 Simulation methodology of open and closed boundaries

For the closed boundary simulations, a fixed number of vehicles were given as an input into the simulation model. Further, these vehicles were on the network for the desired simulation time. While simulating for open boundary

conditions, vehicles were generated at each approach and these vehicles were moving as per the CA rules. At the end of the approach vehicles were deleted and new vehicles were generated based on pre-defined headway. Figure 1a, and 1b describes the methodology to model open and closed boundary simulation of mid-block section. A junction as shown in Figure 4 was adopted for a signalized intersection simulation. Open and closed boundary for intersections were modeled as discussed above with the help of Figure 1c and 1d. CA rules adopted in the current study are modified from those given in existing study<sup>42</sup> suitably. Based on the applications, the rules are divided into three parts. Firstly, rules at the beginning of road model. These rules are different for open and closed boundaries. Secondly, movement rules, these rules are common for open and closed boundaries. Lastly, rules at the end of road are described these rules are different for open and closed boundary models.

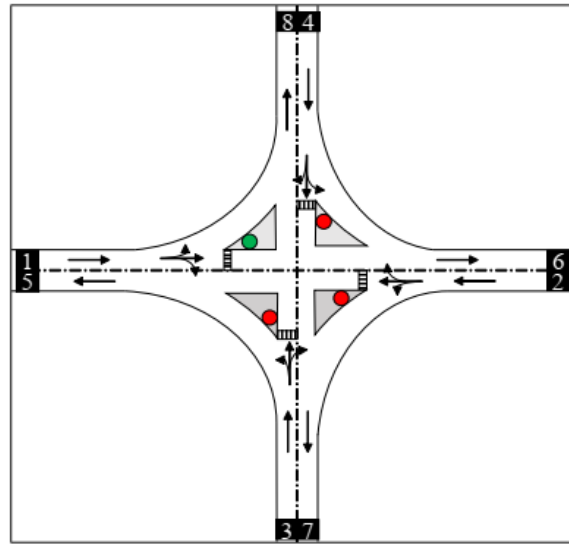

Figure 4 Intersection plan

To understand the complete simulation methodology following algorithm (Figure 5a and 5b) can be used. Firstly the inputs such as density, types of modes, size of vehicles etc. are obtained from the field. Based on these inputs the traffic is generated on the intersection. Different rules are applied to the vehicles based on their position. Vehicles choose different directions to move which can be commonly observed at the intersections. The proportions of movement was taken as an input from the field. Based on the boundary conditions, new vehicles are generated or kept the same. This process is continued for one complete simulation run. The data of flow, speed, density, trajectories etc. is recorded at each time step.

---

### Algorithm for Simulation modelling

---

```
vehicle inputs:
  density
  number of modes
  length of each approach
  sizes of vehicles
  proportion of left, right and straight vehicles
  cycle length
for time = 1 to simulation time
  if closed boundary
    Generate fixed number of vehicles at each approach in first time step
  if open boundary
    Generate vehicles at each approach based on headway
calculate lateral and longitudinal gaps
Apply movement rules
  if vehicles are near the intersection
    decelerate
  elseif vehicle is not near the intersection
    continue moving
When vehicles are near the signal
  if signal is red
    decelerate and stop
    small vehicles calculate gaps and seep
  if signal is not red
    decide direction to move (Left, right or straight)
    continue moving
collect data for analysis
end
```

---

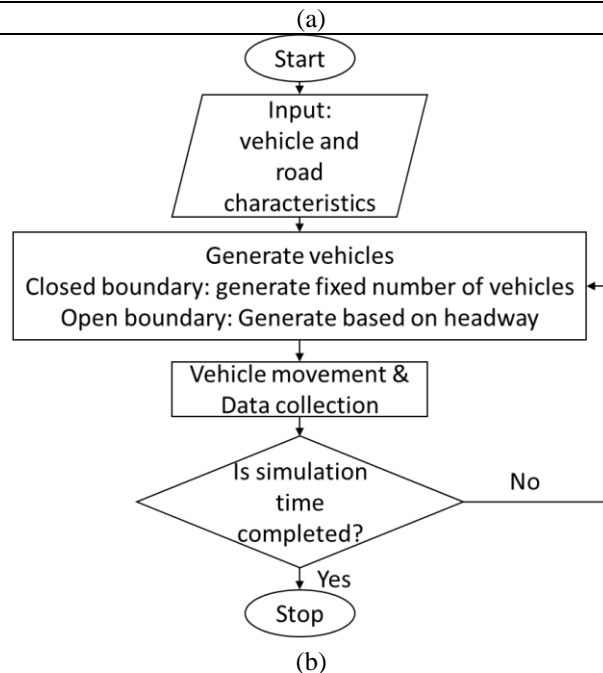

Figure 5 Pseudocode and flow chart for the simulation modelling

### 3.1 Rules at the beginning of road (Vehicle generation rule)

As different inputs are required for open and closed boundary simulations. Hence the following rules for generation of vehicles were added to the model. Current model also includes a rule named as Influence Zone of Intersections

(IZI rule) to separate the intersection and mid-block. Hence only those vehicles who were in the IZI were considered in the junction simulation.

### 3.1.1 Only for closed boundaries

As the number of vehicles are fixed (say  $D$ ) in closed boundary

$$N = \begin{cases} N + 1 \text{ (One vehicle added)}, & \text{if } d_t < D. \\ N \text{ (Stop generating vehicle)}, & \text{if } d_t \geq D. \end{cases} \quad \text{Eqn.-1}$$

Where  $d_t$  is density of vehicle in  $t^{\text{th}}$  time step.  $N$  is number of vehicles. Vehicles are generated till network has desired density ( $D$ ).

### 3.1.2 Only for open boundaries

$$N = \begin{cases} N + 1 \text{ (One vehicle added)}, & \text{if } t = h. \\ N \text{ (No vehicle generated)}, & \text{if } t \neq h. \end{cases} \quad \text{Eqn.-2}$$

Vehicles are generated only when current time ( $t$ ) is an integer multiple of headway ( $h$ ). Different values of  $h$  taken in the study are given in Table 4.

## 3.2 Speed update and movement rules (common for open and closed boundaries)

### 3.2.1 Randomization parameter decision

Randomization parameters are decided based on the situation such as if the brake light of leader is on then  $p_{bl}$  is taken, if the vehicles is stopped then  $p_0$  is used.  $p_{dec}$  is used in all other cases.

$$p = p(v_n^t, b_{n+1}^t, t_n^h, t^s) = \begin{cases} p_{bl} & \text{if } b_{n+1}^t = 1 \text{ and } t_n^h < t^s \\ p_0 & \text{if } v_n^t = 0 \\ p_{dec} & \text{in all other cases} \end{cases} \quad \text{Eqn.-3}$$

$v_n^t$  is  $n^{\text{th}}$  vehicle speed at some time  $t$ ,  $b_{n+1}^t$  is brake light status of leader vehicle at same time  $t$  Time headway available between current and leader current vehicles is denoted by  $t_n^h$  and interaction headway denoted as  $t^s$ .

### 3.2.2 Acceleration

If leader vehicle has not applied brakes and sufficient gap is available, then vehicles may accelerate with the following rule.

$$\text{if } (b_{n+1}^t = 0) \text{ and } (b_n^t = 0) \text{ or } (t_n^h \geq t^s) \text{ then} \quad \text{Eqn.-4}$$

$$v_n^a = \min(v_n^t + a_n(v_n^t, l_n), v_n^{\text{max}})$$

$b_n^t$  is brake light status of current vehicles. Speed acquired through acceleration  $v_n^a$  is calculated without reaching at maximum speed  $v_n^{\text{max}}$ . Acceleration of vehicle is decided with the help of its current speed and length.

### 3.2.3 Braking rule

If sufficient front gap  $g_n^{\text{cf}}$  is not available, then vehicles decelerate and turn on their brake light  $b_{n+1}^t = 1$ . Speed acquired through braking  $v_n^b$  is calculated as follows.

$$v_n^b = \min(v_n^a, g_n^{\text{cf}}), \text{ adopt speed based on available gap} \quad \text{Eqn.-5}$$

$$\text{if } (v_n^b < v_n^t) \text{ (then turn the brake light on, hence)}$$

$$b_n^{t+1} = 1$$



### 3.2.4 Randomization rule

This rule is applied to replicate the vehicles random deceleration behaviour without any assigned reason. This is based on the probability  $p$ . A random number is generated and if the number generated is less than the  $p$ , then a particular rule is applied as discussed below. The applicable  $p$  is decided based on the status of vehicle, for instance if the vehicle is stopped or brake is applied to the vehicle a particular  $p$  between  $p_{bl}$  or  $p_0$  will be chosen.

If  $p$  is applicable due to the brake light or stopped vehicle then

$$v_n^{t+1} = \max(v_n^b - d_n(l_n), 0), \text{ if } (rand() < p) \text{ and } p = p_{bl} \text{ or } p_0 \quad \text{Eqn.-6}$$

For other cases vehicles decelerate with one unit (cell).

$$\begin{aligned} v_n^{t+1} &= \max(v_n^b - d_n(l_n), 0) \text{ if } (p = p_{dec}) \\ b_n^{t+1} &= 1, \text{ if } (p = p_{bl}) \end{aligned} \quad \text{Eqn.-7}$$

Vehicle decelerates when the last vehicle brake light turns on ( $status = 1$ ), sending information of deceleration to the neighbouring vehicles.

### 3.2.5 Car motion

After speed calculations, vehicles move to the next location from current location.

$$x_n^{t+1} = x_n^t + v_n^{t+1} \times 1 \text{ (second)} \quad \text{Eqn.-8}$$

### 3.2.6 Lane changing rule

Following algorithm was used for the lane change (Figure 6). Vehicles compare their own size with the available longitudinal and lateral gaps. If sufficient gap is available, vehicle changes its lane. The lane change is dependent on the mode before them. For example, the trucks have low maximum speed, vehicles change lane and overtake them to move with desired speed.

---

#### Algorithm for lane change

---

Give the Size of Vehicle

```
for v = 1:NumberOfVehicles
    Check Left Side Gap For vehicle(v)
    Check Right Side Gap For vehicle(v)
    Check Front Gap For vehicle(v)
    if Left Side Gap For vehicle(v) >Size Of Vehicle(v)
        Change lane to left
    elseif Right Side Gap For vehicle(v) >Size Of Vehicle(v)
        Change lane to right
    elseif gap between two vehicles > Size of vehicle
        Move through gap between two vehicles
    else
        Move To Front or Slow Down If No Space Is Available
    end
end
end
```

---

Figure 6 Lane changing algorithm

### 3.2.7 Influence zone of intersections (IZI)

Though intersection being a seamless part of the road network, vehicles change their behaviour at the intersection after sighting the traffic signal. The distance within which the vehicles change their behavior near the intersections is called the influence zone of intersections (IZI). Different IZI locations for different modes were found using the GPS survey (Table 3) of vehicles and this was utilized in the simulation model as shown in Figure 7. The vehicles

see the available gaps between the other vehicles and move to the front through them, this behaviour is called seepage and takes place mostly in IZI.

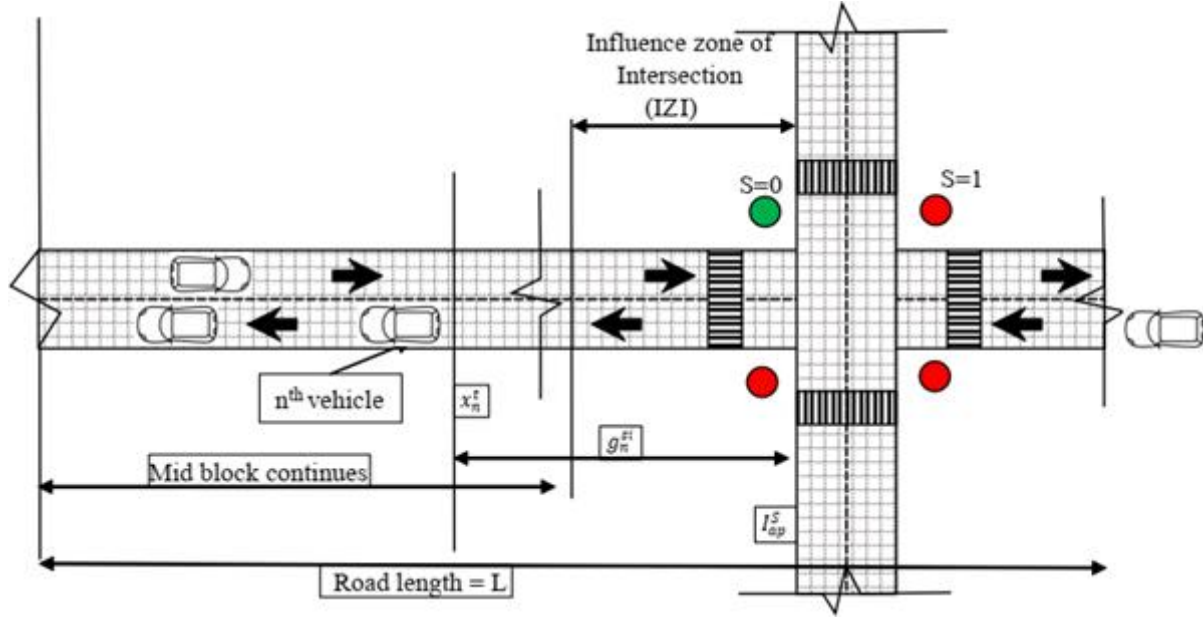

Figure 7 Definition of influence zone of intersection

Table 3 Zone of influence of intersection

Descriptive statistics							N. D. GOF		IZI ( $\mu \pm 1.96\sigma \sqrt{N}$ )	
Mode	N	Mean ( $\mu$ )	St. Dev ( $\sigma$ )	Median	Minimum	Maximum	AD	p	min	max
Car	86	187.39	126.28	184.11	39.10	314.90	0.70	0.06	160.70	214.08
Bus	98	111.26	62.78	113.63	0.50	206.41	0.21	0.85	98.83	123.69
MThW*	79	141.13	74.73	132.64	1.39	212.64	0.58	0.13	124.65	157.61

MThW- Motorized Three-Wheeler, N.D.GOF-normal distribution goodness of fit,  $\mu$  is sample mean,  $\sigma$  is sample standard deviation and N is number of samples. 1.96 is z value at 95% confidence interval.

This rule separates intersection from the mid-block. Once the vehicles are in the IZI they are forced to reduce their speeds, whereas, before and after IZI they can accelerate or decelerate.

$$g_n^{si} = I_{ap}^S - x_n^t \quad \text{Eqn.-9}$$

$g_n^{si}$  is gap of  $n^{\text{th}}$  vehicle from signal, and  $I_{ap}^S$  is the location of a signal where 'S' denotes the signal status i.e. 0 (green signal) or 1 (red) for 'ap' approach.

$$v_n^{t+1} = \begin{cases} v_n^t, & \text{if } IZI_m \geq g_n^{si} \\ \min(v_n^t, g_n^{cf}, g_n^{si}), & \text{if } IZI_m < g_n^{si} \end{cases} \quad \text{Eqn.-10}$$

Where  $IZI_m$  is the zone of influence for mode m, which means that the IZI is different for different modes. The field values of  $IZI_m$  were supplied to the model.

### 3.3 Rules at the end of road

A road length (L) of 100 cells is assumed in this context. Subsequently the following rules were applied to the vehicles that enter this section.

#### 3.3.1 Closed boundaries

If vehicles are near the end, and next step movement location is more than the length of the road (L).

$$x_n^{t+1} = x_n^t + v_n^{t+1} \times 1 \text{ (second)} \quad \text{Eqn.-11a}$$

$$x_n^{t+1} = \begin{cases} x_n^{t+1} - (L(100) - x_n^t) & \text{if } x_n^{t+1} \geq L \\ x_n^{t+1} & \text{if } x_n^{t+1} < L \end{cases} \quad \text{Eqn.-11b}$$

The position of vehicle in upcoming step (t+1) is calculated with Eqn - 11a. The vehicle is recycled back to the beginning of approach with the help of Eqn-11b.

#### 3.3.2 Open boundaries

The position of vehicle in upcoming step (t+1) is calculated with Eqn - 11a. Based on new position of vehicle, vehicle (say  $N_{th}$  vehicle) is either removed or continued in the network (Eqn-12).

$$N_{th} \text{ vehicle} = \begin{cases} 0 & \text{if } x_n^{t+1} \geq L, \text{ Vehicle removed} \\ N_{th} & \text{if } x_n^{t+1} < L, \text{ Vehicle stays in network} \end{cases} \quad \text{Eqn.-12}$$

### 3.4 Some issues with the intersection simulation using closed boundary

Suppose at some instance of time  $t$  vehicle-1 is at position  $X'_{n,p',l'_1}$  (width wise) of right destination approach end. It is possible that other vehicle at the end of other destination approach (say straight approach) is also at  $X'_{m,p',l'_1}$  (width wise) position (Figure 8). Now in the next time step, speeds get updated and vehicles are ready to be assigned a new position in a closed boundary simulation model. That new position will be some position at the beginning of initial approach, from where vehicles have diverted to the respective destination approaches (left, right or left). The positions of any of the two vehicles namely vehicle-1 and 2 as shown in Figure 8, their positions are calculated as follows.

Vehicle-1 at time step  $t+1$  will be at some position where its position will be more than road length, hence it will come somewhere at the beginning of the road.

$$\begin{aligned} x_{m,p',l'_2}^{t+1} &= x_{m,p,l_2}^t + v_m^{t+1} \times 1 \text{ (second)} \geq L & \text{Eqn.-13} \\ &= L(1) + v_m^{t+1} - (L(100) - x_{m,p,l_2}^t) \end{aligned}$$

$x_{m,p',l'_2}^{t+1}$  is the location of  $m^{th}$  vehicle at  $t+1$  time instance.  $p'$  is widthwise location and  $l'_2$  is length wise location.

Similarly, vehicle-2 at time step  $t+1$  will be at following location

$$\begin{aligned} x_{n,p',l'_2}^{t+1} &= x_{n,p,l_2}^t + v_n^{t+1} \times 1 \text{ (second)} \geq L & \text{Eqn.-14} \\ &= L(1) + v_n^{t+1} - (L(100) - x_{n,p,l_2}^t) \end{aligned}$$

$x_{n,p',l'_2}^{t+1}$  is the location of  $n^{th}$  vehicle at  $t+1$  time instance.  $p'$  is widthwise location and  $l'_2$  is length wise location.

As the vehicles are in closed boundary, the condition that will arise frequently is

$$x_{n,p',l'_2}^{t+1} = x_{m,p',l'_2}^{t+1} \text{ OR } x_{n,p',l'_2}^{t+1} \approx x_{m,p',l'_2}^{t+1} \quad \text{Eqn.-15}$$

If the positions of both the vehicles are not equal then there will not be any problem, but if they are equal or overlapping then it will affect the simulation results as the vehicles have to refresh (warmup) again to simulate normally. Hence a closed boundary should be avoided in intersection simulation, or whenever vehicles divert to different directions.

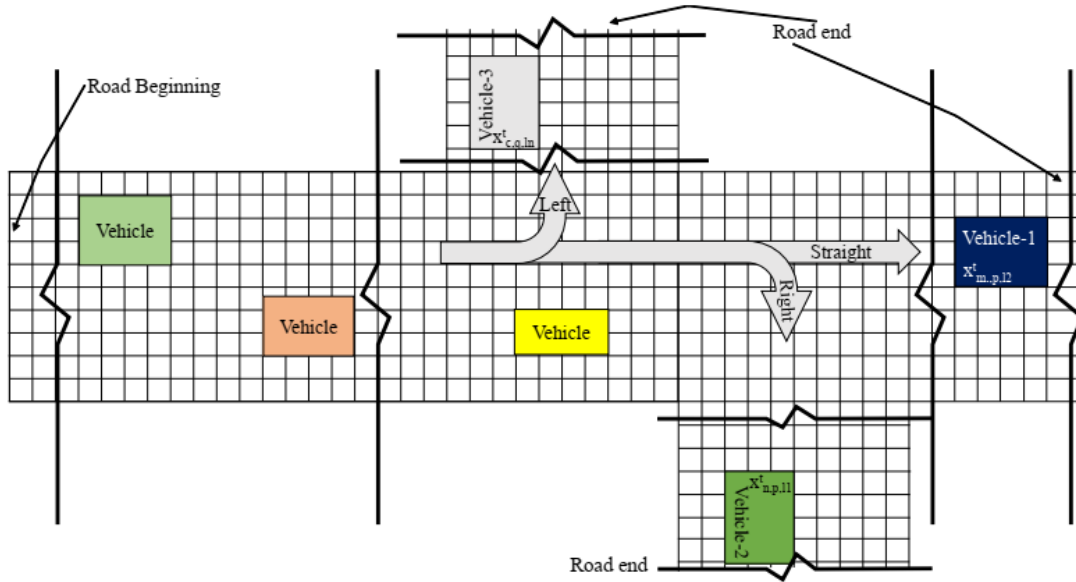

Figure 8 Vehicle positions in the simulation at one approach diverting to three directions

It was also found that closed boundary simulations take more time than open boundary simulations. In closed boundary conditions vehicles are on the network for complete simulation time keeping all movement data, the size of the data increases with each simulation step hence computation speed reduces, whereas in open boundary conditions the information is stored as long as vehicles are on the network, after that the vehicle information is stored in a variable and vehicle is deleted from the network hence these are faster. 96 simulations of closed boundary took 707:92 hours, whereas open boundary simulations took 329:82 hours. All simulations were run on MATLAB software installed on Linux based high performance computing (HPC) system with 12CPUs of 64GB RAM.

### 3.5 Simulation Plan

Simulation was designed for 96 (6 combinations of traffic composition  $\times$  4 combinations of occupancies  $\times$  4 types of boundaries) times for all the different boundaries (mid-block closed and open, intersection closed and open). Out of those combinations, 40; 30 and 20% of buses and 40; 30 and 10% of motorized three wheelers were excluded in the study as these proportion were not observed in the field survey done in Delhi (India). Traffic composition and

occupancy of the traffic was changed to see the effect of these at different boundaries of intersection. As the input to the open boundary simulation is flow whereas the input to the closed boundaries is occupancy or the density of vehicles hence density equivalent to flow was given as input to the simulation models, to keep the input consistent for comparison. The headway was taken as high as 7.2 seconds for low flow, and lowest density was calculated with this flow was 50 vehicles per kilometer. The headway was increased to produce flow of 500; 1000; 1500 and 2000 vehicles. The cell size considered was 0.5m × 0.7m (length × width). The lane width was taken as 3.5 meters hence width wise there are 3.5/0.7 = 5 cells in each lane. The length of the road was taken as 1 km which is 1000/0.5 = 2000 cells in length. Hence, there would be 2000 × 5 = 10000 cells in a single lane of the road. The flow of the vehicles was converted to instantaneous occupancy using the following equation.

$$Occupancy = \frac{flow}{numer\ of\ cells} = \frac{flow}{10000} \quad \text{Eqn.-16}$$

Table 4 Feasible compositions of traffic flow modes

S. No.	Motorized Two-Wheeler (MTW)	Motorized Three-Wheeler (MThW)	Bus	Car	For closed Boundary		for open boundaries	
					Occupancy	Density	Headway (3600/Flow)	Flow
1	1	0	0	0	0.05	50	7.2	500
2	0	1	0	0	0.05	50	7.2	500
3	0	0	1	0	0.05	50	7.2	500
4	0	0	0	1	0.05	50	7.2	500
5	0.4	0.2	0.1	0.3	0.05	50	7.2	500
6	0.3	0.2	0.1	0.4	0.05	50	7.2	500
7	1	0	0	0	0.1	100	3.6	1000
8	0	1	0	0	0.1	100	3.6	1000
9	0	0	1	0	0.1	100	3.6	1000
10	0	0	0	1	0.1	100	3.6	1000
11	0.4	0.2	0.1	0.3	0.1	100	3.6	1000
12	0.3	0.2	0.1	0.4	0.1	100	3.6	1000
13	1	0	0	0	0.15	150	2.4	1500
14	0	1	0	0	0.15	150	2.4	1500
15	0	0	1	0	0.15	150	2.4	1500
16	0	0	0	1	0.15	150	2.4	1500
17	0.4	0.2	0.1	0.3	0.15	150	2.4	1500
18	0.3	0.2	0.1	0.4	0.15	150	2.4	1500
19	1	0	0	0	0.2	200	1.8	2000
20	0	1	0	0	0.2	200	1.8	2000
21	0	0	1	0	0.2	200	1.8	2000
22	0	0	0	1	0.2	200	1.8	2000
23	0.4	0.2	0.1	0.3	0.2	200	1.8	2000
24	0.3	0.2	0.1	0.4	0.2	200	1.8	2000

Occupancy means the number of occupied cells in one-kilometer road. The density or occupancy for closed boundary simulation was calculated from the headway or flow of the vehicles (Table 4).

## 4 Simulation Results

If there is no overtaking, seepage behaviour and speeds of the small and large vehicles such as motorized two wheelers and cars is equal then simulation evidence (Figure 9) shows that the fundamental diagrams will have no difference for both the modes. Hence it can be concluded that the size of vehicles doesn't change the fundamental

diagrams (FDs) if vehicles adhere to the lane keeping behaviour with equal speeds. The fundamental diagram changes based on the range of the speeds, such as when the stream comprises buses (Figure 9). This behaviour is useful to explain the fundamental diagrams observed in present study

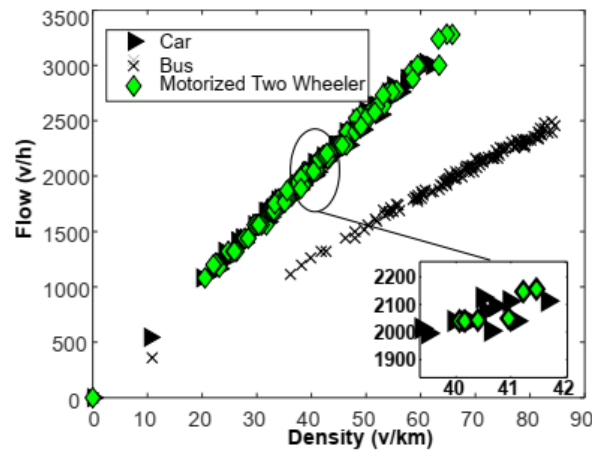
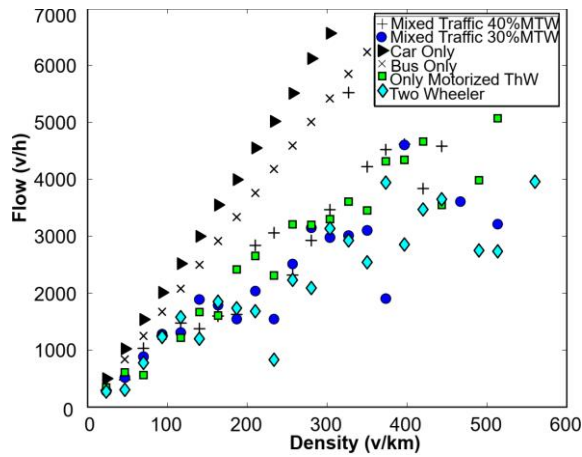

Figure 9 Pure homogeneous traffic simulation, without lane change and overtaking behaviour

Simulations were carried with the same parameters and rules as discussed above for open and closed boundaries at mid-block and signalized intersection, with different boundary conditions. Further, axis limits were changed to observe the pattern of FDs.

#### 4.1 Behaviour at the mid-block

Simulation results for open and closed boundary conditions at mid-blocks are shown in Figure 10a and 10b. It can also be seen that with closed boundary simulations, with two wheelers having the highest flow, which is the same as in open boundaries. But the behaviour of two wheelers is different from other modes, the reason for this could be because two wheelers have small size and high maneuverability, hence they seep. To model a closed boundary condition present study uses occupancy as percentage of cells to fill the road with the vehicles. How many cells a vehicle will occupy is decided based on its size. Size of two wheelers is small compare to other modes, hence a greater number of two wheelers are generated for any occupancy. Thus, in the beginning of closed boundary simulations the flow of two wheelers is less with high density compared to other modes, hence flow-density curve of two-wheeler is having a mild slope. The present model also incorporates the seepage behaviour of vehicles in which vehicles use the gaps left between neighboring vehicles and move forward, hence the speeds of two wheelers is less while they are in the activity of seepage hence their flow is reduced for some time, but overall they show a higher flow compare to other modes (Figure 10a and 10b). Without this characteristic, the fundamental diagrams for different modes are similar as shown in Figure 9. It can be proved that at certain flow, if vehicles seep, then the smaller size vehicles will have higher density, which can be observed in the Figure 10a and 10b.



(a) Open boundary with headway = 7.2 sec  
MTW-Motorized two-wheeler

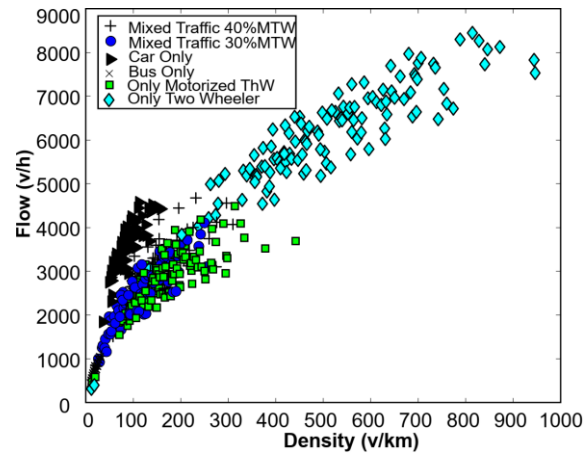

(b) Closed boundary with occupancy = 0.05  
MTW-Motorized two-wheeler

Figure 10 Simulation results of mid-block section with different traffic conditions

## 4.2 Behaviour at the intersection

Following figure shows the traffic behaviour at the intersections (Figure 11a and 11b). A similar behaviour of two wheelers at the intersection is visible as in the mid-block section discussed above. Two wheelers flow in closed boundary simulation are away with less slope from other modes whereas in open boundary simulations they are closer to trends of other modes. The milder slope of the two wheelers shows the seepage behaviour and the linear behaviour of modes shows the homogeneity when single modes are chosen. A more realistic behaviour is observable in open boundary simulation. Similar to the behaviour observed at the mid-blocks, in intersection also the staggered trends are observed in open boundary simulations. More theoretical trends can be observed in the results of closed boundary simulation as the homogeneity (continuous linear trend of individual mode) is perfectly followed by all the figures of closed boundary simulations.

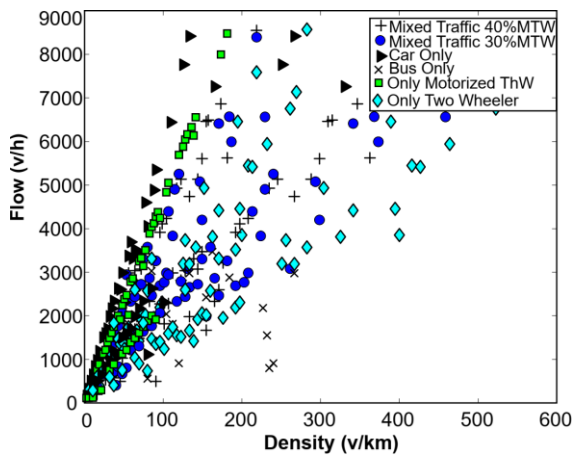

(a) Open boundary with headway = 7.2 sec  
MTW-Motorized two-wheeler

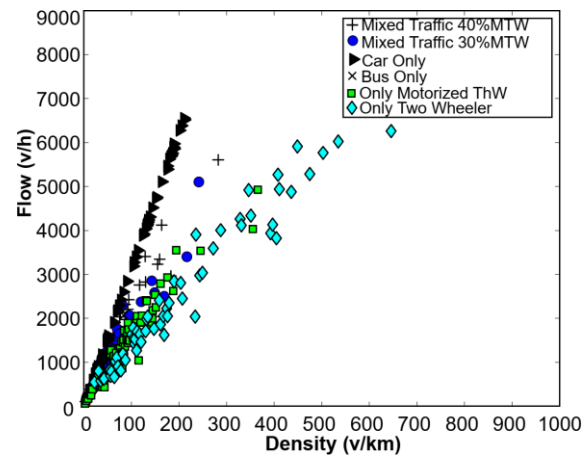

(b) Closed boundary with occupancy = 0.05  
MTW-Motorized two-wheeler

Figure 11 Simulation results of signalized intersection with different traffic conditions

As the occupancy increases for closed boundaries (Appendix A, B. Fig. a, c, e) or the headway decreases for open boundary conditions (Appendix A, B. Fig. b, d, f), higher flows and densities can be observed. Staggered behaviour can be observed in the open boundary conditions, whereas the trends shown by closed boundary conditions are less staggered. The linear trend in the results of open boundaries in mid-block is produced with the homogeneous traffic. As the heterogeneity is introduced into the model with more modes, the staggered trends are observed. Two wheelers in closed boundary simulations show higher flows compared to other modes and open boundary simulation

results. Trends of fundamental diagrams for smaller and higher size vehicles show that the flow (in number of vehicles per hour) is higher for small size vehicles (i.e., Chunchu and Kalaga<sup>50</sup> and Figure 9); this is theoretically valid as in a particular space large number of smaller size vehicles can be accommodated compared to fewer larger size vehicles. This can be observed in either of the boundary condition results.

## 5 Conclusions

Many studies have been carried out on the boundary condition selection in the simulation models. This study attempts to look into the effect of the choice of boundary conditions on the outcomes. This paper describes some of the commonly observe but often ignored traffic features such as seepage and zone of influence of intersection. Some of the salient outcomes of this study are:

- Closed boundary simulations take more time than open boundary simulations (Section 3.4).
- Size of the vehicles does not change the fundamental diagrams unless lane change, seepage and different maximum speeds are given to different modes (Section 4 and Figure 9 to 11).
- Simulation results of both the boundaries are different, closed boundaries provide more theoretical results whereas open boundaries are more staggered at times open boundary simulation can be preferred to get more realistic results (Figure 10, 11, Appendix A and Appendix B).
- In the closed boundary conditions at intersections, there are problems associated with the sequence in which the returning vehicles have to reach the target approach (Section 3.4). Additional warmup time and space is required to achieve this sequencing task.
- If simulation of some facilities (i.e., bus stop) is done in CA modelling using periodic boundaries then one has to assume that the facilities are at a fixed interval which is unrealistic assumption.

### 5.1 Future recommendations

Present study included 2 lanes mid-block and intersection with 4 types of vehicles named as cars, buses, motorized-two-wheelers and motorized-three-wheelers. More number of modes can be added in the future studies. This research can be extended with incorporation of determination of probability of placement of returning vehicle on destination approach or some other methodology can be developed to resolve this issue. The present study can be further developed for mixed traffic conditions with autonomous vehicles using vehicle to infrastructure (V2I) communication<sup>51</sup>. The CA models work on discrete time step and may show inaccurate results. The limitations of CAs can be overcome with the application of DEVS (discrete events systems specification)<sup>52</sup>. Present study can be modified to develop a model with cell-DEVS.

## 6 References

1. von Bertalanffy L. *General Systems Theory: Foundations, Developments, Applications*. Second Edition, George Braziller, 1969, New York,.
2. Barlovic R, Huisinga T, Schadschneider A, et al. Open boundaries in a cellular automaton model for traffic flow with metastable states. *Phys Rev E* 2002; 66: 46113.
3. Popkov V, Santen L, Schadschneider A, et al. Empirical evidence for a boundary-induced nonequilibrium phase transition. *J Phys A Math Gen* 2001; 34: L45.
4. Allport GW. The open system in personality theory. *J Abnorm Soc Psychol* 1960; 61: 301–310.
5. von Bertalanffy L. The Theory of Open Systems in Physics and Biology. *Science (80- )* 1950; 111: 23 LP – 29.
6. Clark J, Daigle G. The importance of simulation techniques in ITS research and analysis. In: *Proceedings of the 29th conference on Winter simulation - WSC '97*. New York, New York, USA: ACM Press, pp. 1236–1243.



7. Treiber M, Kesting A. *Traffic flow dynamics*. Springer, 2013.
8. Popkov V, Schütz GM. Steady-state selection in driven diffusive systems with open boundaries. *EPL (Europhysics Lett)* 1999; 48: 257.
9. Brockfeld E, Barlovic R, Schadschneider A, et al. Optimizing traffic lights in a cellular automaton model for city traffic. *Phys Rev E Stat Nonlin Soft Matter Phys* 2001; 64: 056132.
10. Jia N, Ma S. Analytical results of the Nagel-Schreckenberg model with stochastic open boundary conditions. *Phys Rev E* 2009; 80: 041105.
11. Schadschneider A, Chowdhury D, Nishinari K. *Stochastic transport in complex systems: from molecules to vehicles*. Elsevier, 2010.
12. Agarwal A, Gregor L, Lämmel G, et al. Modeling Seepage Behavior of Smaller Vehicles in Mixed Traffic Conditions Using an Agent Based Simulation. *Transp Dev Econ* 2016; 2: 8.
13. Singh MK, Rao KR. Cellular automata models for signalised and unsignalised intersections with special attention to mixed traffic flow: A review. *IET Intell Transp Syst* 2020; 14: 1507–1516.
14. Zhang Y, Duan H. Modeling mixed traffic flow at crosswalks in microsimulations using cellular automata. *Tsinghua Sci Technol* 2007; 12: 214–222.
15. Fouladvand ME, Sadjadi Z, Shaebani MR. Optimized traffic flow at a single intersection: traffic responsive signalization. *J Phys A Math Gen* 2004; 37: 561–576.
16. Tian L. Traffic Flow Simulation in a Scenario with Signalized Intersection and Bus Stop. *J Transp Syst Eng Inf Technol* 2012; 12: 90–96.
17. Luo Y-J, Jia B, Li X-G, et al. A realistic cellular automata model of bus route system based on open boundary. *Transp Res Part C Emerg Technol* 2012; 25: 202–213.
18. Radhakrishnan P, Mathew T V. Hybrid stochastic cellular automata-driver-vehicle-object simulation model for heterogeneous traffic at urban signalized intersections. *J Comput Civ Eng* 2013; 27: 254–262.
19. Chai C, Wong YD. Traffic performance of shared lanes at signalized intersections based on cellular automata modeling. *J Adv Transp* 2014; 48: 1051–1065.
20. Ren G, Jiang H, Chen J, et al. Heterogeneous cellular automata model for straight-through bicycle traffic at signalized intersection. *Phys A Stat Mech its Appl* 2016; 451: 70–83.
21. Li X, Sun J-QQ. Effects of turning and through lane sharing on traffic performance at intersections. *Phys A Stat Mech its Appl* 2016; 444: 622–640.
22. Zhao H-T, Liu X-R, Chen X-X, et al. Cellular automata model for traffic flow at intersections in internet of vehicles. *Phys A Stat Mech its Appl* 2018; 494: 40–51.
23. Wang Y, Chen Y-Y, Yang W, et al. A new cellular automaton for signal controlled traffic flow based on driving behaviors. *Chinese Phys B* 2015; 24: 38902.
24. Tadaki S. Two-dimensional cellular automaton model of traffic flow with open boundaries. *Phys Rev E* 1996; 54: 2409.
25. Cheybani S, Kertesz J, Schreckenberg M. Nondeterministic Nagel-Schreckenberg traffic model with open boundary conditions. *Phys Rev E* 2000; 63: 16108.
26. Mitarai N, Nakanishi H. Spatiotemporal structure of traffic flow in a system with an open boundary. *Phys Rev Lett* 2000; 85: 1766.
27. Jiang R, Wu Q-S. Open boundaries in a cellular automata model for synchronized flow: Effects of nonmonotonicity. *Phys Rev E* 2003; 68: 026135.

28. Jia N, Ma S. Analytical investigation of the open boundary conditions in the Nagel-Schreckenberg model. *Phys Rev E* 2009; 79: 31115.
29. Meng Q, Weng J. Cellular Automata Model for Work Zone Traffic. *Transp Res Rec J Transp Res Board* 2010; 2188: 131–139.
30. Marzoug R, Ez-Zahraouy H, Benyoussef A. Simulation study of car accidents at the intersection of two roads in the mixed traffic flow. *Int J Mod Phys C* 2015; 26: 1550007.
31. Biham O, Middleton AA, Levine D. Self-organization and a dynamical transition in traffic-flow models. *Phys Rev A* 1992; 46: R6124--R6127.
32. Nagatani T, Seno T. Traffic jam induced by a crosscut road in a traffic-flow model. *Phys A Stat Mech its Appl* 1994; 207: 574–583.
33. Chung KH, Hui PM, Gu GQ. Two-dimensional traffic flow problems with faulty traffic lights. *Phys Rev E* 1995; 51: 772–774.
34. Benjamin SC, Johnson NF, Hui PM. Cellular automata models of traffic flow along a highway containing a junction. *J Phys A Math Gen* 1996; 29: 3119–3127.
35. Feng S, Gu G, Dai S, et al. Effects of traffic lights on CA traffic model. *Commun Nonlinear Sci Numer Simul* 1997; 2: 70–74.
36. Chowdhury D, Schadschneider A. Self-organization of traffic jams in cities: Effects of stochastic dynamics and signal periods. *Phys Rev E* 1999; 59: R1311--R1314.
37. Shi J, Cheng L, Long J, et al. A New Cellular Automaton Model for Urban Two-Way Road Networks. *Comput Intell Neurosci* 2014; 2014: 1–6.
38. Huang D, Huang W. Traffic signal synchronization. *Phys Rev E Stat Nonlin Soft Matter Phys* 2003; 67: 056124.
39. Emmerich H, Rank E. An improved cellular automaton model for traffic flow simulation. *Phys A Stat Mech its Appl* 1997; 234: 676–686.
40. Lárraga ME, Ríó JA del, Alvarez-Icaza L. Cellular automata for one-lane traffic flow modeling. *Transp Res Part C Emerg Technol* 2005; 13: 63–74.
41. Mallikarjuna C, Rao KR. Cellular automata model for heterogeneous traffic. *J Adv Transp* 2009; 43: 321–345.
42. Pandey G, Rao KR, Mohan D. Modelling vehicular interactions for heterogeneous traffic flow using cellular automata with position preference. *J Mod Transp* 2017; 25: 163–177.
43. Singh MK, Pandey G, Rao KR. Optimization of Work Zone Segments on Urban Roads Using Cellular Automata Model in Mixed Traffic. *Period Polytech Transp Eng* 2019; 47: 29–35.
44. Zamith M, Leal-Toledo RCP, Kischinhevsky M, et al. A probabilistic cellular automata model for highway traffic simulation. In: *Procedia Computer Science*, pp. 337–345.
45. Raheja T. Modelling traffic congestion using queuing networks. *Sadhana* 2010; 35: 427–431.
46. Li XX, Yan X, Li XX, et al. Using Cellular Automata to Investigate Pedestrian Conflicts with Vehicles in Crosswalk at Signalized Intersection. *Discret Dyn Nat Soc* 2012; 2012: 1–16.
47. Xie D-F, Gao Z-Y, Zhao X-M, et al. Cellular Automaton Modeling of the Interaction between Vehicles and Pedestrians at Signalized Crosswalk. *J Transp Eng* 2012; 138: 1442–1452.
48. Schroeder B, Wierman A, Harchol-Balter M. Open versus closed: a cautionary tale. *Proc 3rd Conf Networked Syst Des Implement*; 1, <http://dl.acm.org/citation.cfm?id=1267680.1267698> (2006).

49. Nagel K, Schreckenberg M. A cellular automaton model for freeway traffic. *J Phys I* 1992; 2: 2221–2229.
50. Chunchu M, Kalaga RR. Identification of A Suitable Cellular Automata Model for Mixed Traffic. *Proc East Asia Soc Transp Stud* 2007; 2007: 321.
51. Małecki K, Gabryś M. The computer simulation of cellular automata traffic model with the consideration of vehicle-to-infrastructure communication technology. *Simulation* 2020; 96: 911–923.
52. Wainer GA. Advanced Cell-DEVS modeling applications: a legacy of Norbert Giambiasi. *Simulation* 2018; 003754971876159.

## Appendix A: Mid-block simulation results

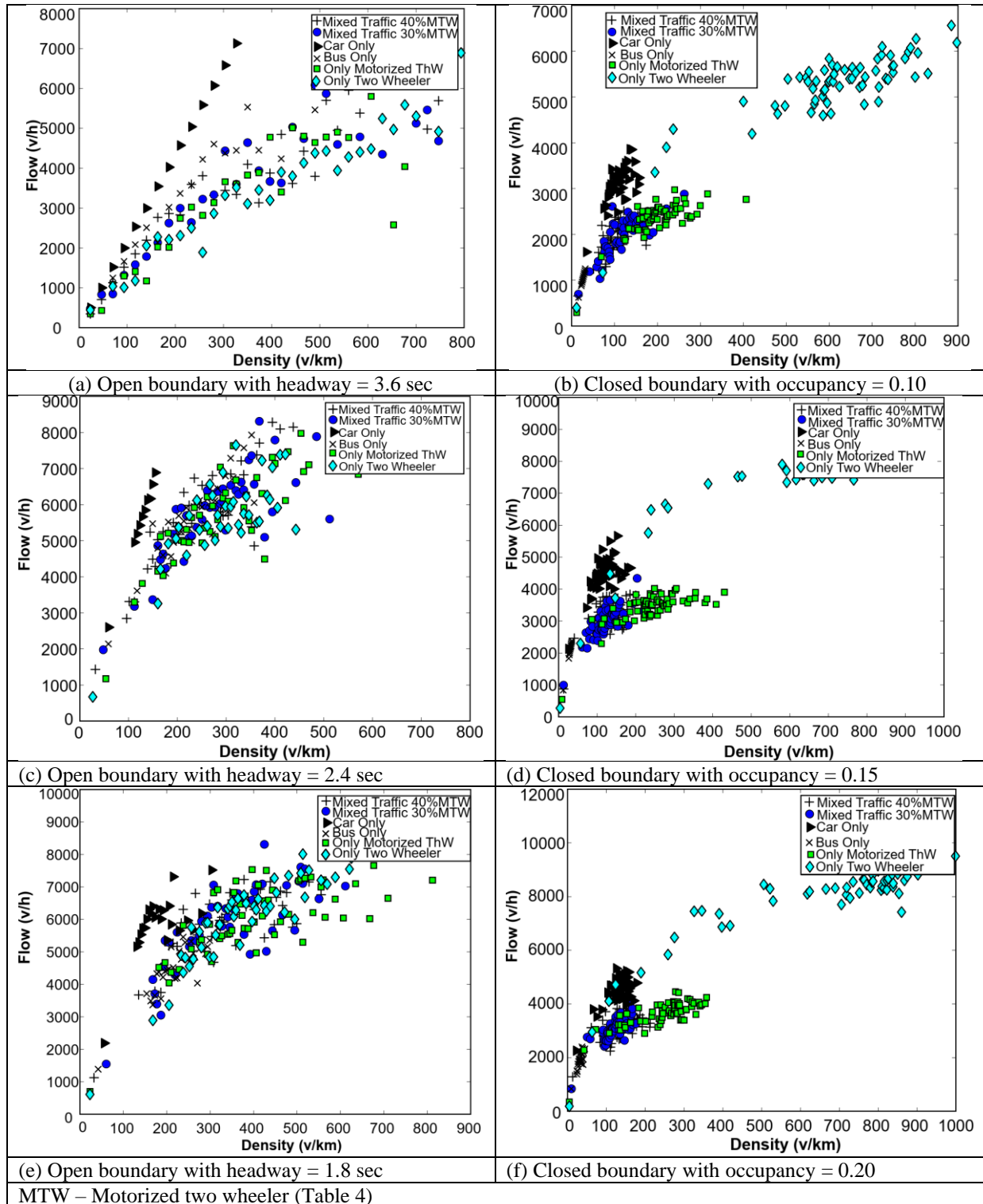

## Appendix B: Intersection simulation results

