



**Aalborg Universitet**

**AALBORG UNIVERSITY**  
DENMARK

## **Validation of Boundary Conditions for CFD Simulations on Ventilated Rooms**

Topp, Claus; Jensen, Rasmus Lund; Pedersen, D. N.; Nielsen, Peter Vilhelm

*Published in:*

Proceedings of the 4th International Conference on Indoor Air Quality, Ventilation & Energy Conservation in Buildings, IAQVEC 2001, Changsha, Hunan, China, October 2-5, 2001

*Publication date:*

2001

*Document Version*

Publisher's PDF, also known as Version of record

[Link to publication from Aalborg University](#)

*Citation for published version (APA):*

Topp, C., Jensen, R. L., Pedersen, D. N., & Nielsen, P. V. (2001). Validation of Boundary Conditions for CFD Simulations on Ventilated Rooms. In Proceedings of the 4th International Conference on Indoor Air Quality, Ventilation & Energy Conservation in Buildings, IAQVEC 2001, Changsha, Hunan, China, October 2-5, 2001 (pp. Vol. 1, pp. 295-302)

### **General rights**

Copyright and moral rights for the publications made accessible in the public portal are retained by the authors and/or other copyright owners and it is a condition of accessing publications that users recognise and abide by the legal requirements associated with these rights.

- ? Users may download and print one copy of any publication from the public portal for the purpose of private study or research.
- ? You may not further distribute the material or use it for any profit-making activity or commercial gain
- ? You may freely distribute the URL identifying the publication in the public portal ?

### **Take down policy**

If you believe that this document breaches copyright please contact us at [vbn@aub.aau.dk](mailto:vbn@aub.aau.dk) providing details, and we will remove access to the work immediately and investigate your claim.

# Validation of Boundary Conditions for CFD Simulations on Ventilated Rooms

Claus Topp, Rasmus L. Jensen, Dorte N. Pedersen and Peter V. Nielsen  
Department of Building Technology and Structural Engineering  
Aalborg University  
Sohngaardsholmsvej 57  
DK-9000 Aalborg  
Denmark

## ABSTRACT

The application of Computational Fluid Dynamics (CFD) for ventilation research and design of ventilation systems has increased during the recent years. This paper provides an investigation of direct description of boundary conditions for a complex inlet diffuser and a heated surface.

A series of full-scale experiments in a room ventilated by the mixing principle have been performed for validation of the models. The experimental results include measurements of temperature as well as measurements of velocity and turbulence by Laser Doppler Anemometry (LDA).

A simple model of the complex inlet diffuser showed good agreement with the experimentally obtained results although differences were observed in the flow far from the inlet. None of the investigated models of the heated surface did provide satisfactory results.

## INTRODUCTION

The application of Computational Fluid Dynamics (CFD) for ventilation research and design of ventilation systems has increased during the recent years. In research CFD has proved to be a strong tool to conveniently extend the range of experimentally obtained results by parameter variation while in the design of ventilation systems CFD provides detailed information for evaluation of thermal and atmospheric comfort.

A weak spot in CFD however, is the modelling of boundary conditions where simple models are often preferred as they are less time consuming both in the set-up procedure and when performing the simulations. This may lead to fully or partly incorrect results as the quality of CFD simulations are closely related to the quality of the boundary conditions.

In literature several authors have addressed the topic of modelling complex inlet geometries and thereby save computer time and storage. Nielsen (1992) proposed *the box method* in which the inlet boundary condition is given at some distance from the inlet opening. This method excludes prediction of variables in a box in front of the inlet but requires measured values for the actual diffuser to be used as boundary

condition. Gosman et al. (1980) proposed *the prescribed velocity method*. In this method analytical or experimentally obtained velocities are prescribed in a volume in front of the inlet excluding prediction of velocities in this region. In a more recent study Huo et al. (2000) provides *the jet main region specification method* based on the box method by Nielsen (1992). The method applies analytical data to the box and a guideline for selection of the box is given.

The above-mentioned methods all rely on either experimentally or analytically obtained data in order to model complex inlet geometries. Another way to handle complex inlet geometries is by simplifying the geometry and apply a traditional description of the inlet boundary condition which is the topic of the present work.

It has been the objective of the present work to investigate the modelling of boundary conditions in a ventilated room. The effort has been focussed on modelling a complex inlet diffuser ranging from very simple to an almost perfect model of the actual geometry. In addition, the representation of a heated surface has been investigated.

## **METHODS**

A series of CFD simulations as well as full-scale experiments for validation purposes have been performed for an office-sized room ventilated by the mixing principle, see Figure 1. The room is supplied with air by an inlet diffuser mounted at one end wall and the return opening is located just below. At the opposite wall a heated surface is introduced in some of the simulations and corresponding experiments.

The inlet diffuser consists of 84 nozzles directing the air towards the ceiling in an angle of 40° as shown in Figure 2 and Figure 3. The diffuser is similar to the diffuser used in the IEA Annex 20 programme and is thus well known both in terms of experiments and CFD (Chen and Moser, 1991; Heikkinen, 1991 and Fontaine, 1994).

Isothermal CFD simulations with three different geometric simplifications of the inlet diffuser have been performed (see Figure 4). In the simplified models air is supplied through one or more holes in the wall and the geometry of the diffuser inside the room has thus been neglected as it is considered to be without any significant influence on the airflow. The inlet area corresponds in all models to that of the actual diffuser. The diffusers investigated are:

- A. Same width as actual diffuser
- B. 1.5 time width of actual diffuser
- C. 84 quadratic nozzles

The heated surface consists of four panels as shown in Figure 5. CFD simulations were performed for three different models of the heated surface:

- One surface with a prescribed heat flux
- One surface with a prescribed temperature
- Four surfaces with a prescribed heat flux

All CFD simulations have been performed with a commercial software package. Turbulence has been modelled with the standard k- $\epsilon$  turbulence model. In the cases with diffuser A and B the full CFD model contained approximately 70.000 cells while for diffuser C the model was resolved into approximately 250.000 cells due to the higher level of complexity.

The full-scale experiments include measurements of temperature by thermocouples as well as measurements of velocity and turbulence by Laser Doppler Anemometry (LDA) and hot-sphere anemometers.

All experiments as well as CFD simulations were performed at an air change rate of  $3 \text{ h}^{-1}$ .

## RESULTS

A recirculating flow was observed in the full-scale experiments (see Figure 6) both in the isothermal and non-isothermal cases. The velocity level in the flow along the end wall was reduced due to buoyancy when the heated surface was introduced.

### Inlet diffuser

All simulations and corresponding experiments presented in this section are isothermal. In general the different diffuser models are unable to accurately predict the recirculation zone above the diffuser as the jet hits the ceiling closer to the corner than found in the experiments (Figure 7).

It is seen from the horizontal velocity profiles (Figure 8) that even at a distance of 3 m from the inlet the experimental results show the jet to be almost symmetric around the x-axis. The symmetric behaviour is also observed for diffuser A and B while for diffuser C the jet centre is located at  $z \approx -0.25 \text{ m}$ . It also appears that all of the diffusers predict a more narrow jet than the experiments although the maximum velocities agree well.

Figure 9 illustrates the jet development along the ceiling by vertical velocity profiles in the jet centreline. It should be noticed that the jet centreline for diffuser C is not identical to the room centreline due to the jet asymmetry. The profiles in general express good agreement with the experimental results both in terms of jet thickness and maximum velocity with diffuser A and B providing the better predictions.

As illustrated in Figure 6 the jet forms a recirculating flow pattern in the room. The velocity decay of this recirculating flow is shown in Figure 10 for the experimental results and the results obtained with diffuser B. It should be noticed that x is a coordinate measured successive along the ceiling, the end wall and the floor. The value of x in the lower corner is thus  $4.2 \text{ m} + 2.5 \text{ m} = 6.7 \text{ m}$ .

From Figure 10 it is seen that the CFD model provides a good prediction of the velocity decay along the ceiling, as expected from the vertical velocity profiles (Figure 9), while some difference is observed in the floor region.

## **Heated surface**

All CFD predictions presented in this section have been performed with diffuser B. The experimental boundary conditions are shown in Table 1.

The different models of the heated surface are validated against velocity profiles obtained by Laser Doppler Anemometry, see Figure 11. From the experimental results it appears that the buoyancy effects due to the heated surface are overwhelmed by the momentum of the recirculating flow as the air is flowing downwards even very close (3 – 8 mm) to the heated surface. This flow pattern is not seen from the CFD results as they all predict an upward flow close to the heated surface. The better prediction though is found when the heated surface is modelled as four surfaces with a prescribed heat flux.

## **DISCUSSION**

A series of CFD simulations and corresponding experiments have been performed to validate different boundary conditions for a complex diffuser and a heated surface.

The results show that a simplified geometric model of a complex diffuser can provide good CFD predictions of the bulk room airflow although local differences occur. In fact the more complex of the models investigated (diffuser C) was not able to predict the symmetric behaviour of the jet as observed in the experiments. None of the models though predicted the correct width of the jet while the thickness and the maximum velocities agreed well with experiments. This indicates a difference in the jet volume flow due to different horizontal entrainment.

The expense of applying a simplified geometric model is obviously that the flow cannot be accurately predicted close to the diffuser. However, as the interest in room air ventilation is often focused on the bulk airflow pattern in a room a simplified geometric model can in most cases represent a complex diffuser and provide the accuracy required.

When introducing a heated surface the recirculating flow dominates buoyancy and creates a downward flow along the heated surface as illustrated by the experiments. This phenomenon was not accurately predicted by any of the CFD models.

In general a prescribed heat flux is expected to provide better results than a prescribed temperature, as the heat flux is specified and thus independent of grid distribution. This is also the case in the present investigation as the better result is obtained with an accurate representation of the geometry (four surfaces) and a prescribed heat flux, although none of the models investigated did provide satisfactory results.

## **ACKNOWLEDGEMENT**

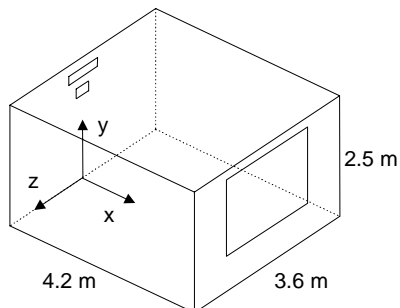
This research was funded by the Danish Technical Research Council (STVF) as a part of the International Centre for Indoor Environment and Energy at the Technical University of Denmark.

## REFERENCES

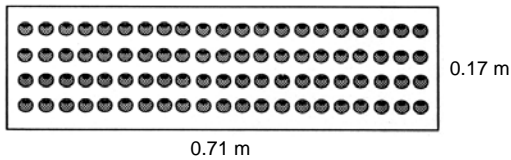
1. P. V. Nielsen, "Description of supply openings in numerical models for room air distribution", ASHRAE Transactions, Vol. 98 (1), 963-971, 1992.
2. A. D. Gosman, P. V. Nielsen, A. Restivo and J. H. Whitelaw, "The flow properties of rooms with small ventilation openings", Journal of Fluids Engineering, Vol. 102, 316-323, 1980.
3. Y. Huo, F. Haghghat, J. S. Zhang and C. Y. Shaw, "A systematic approach to describe the air terminal device in CFD simulation for room air distribution analysis", Building and Environment, Vol. 35, 563-576, 2000.
4. Q. Chen and A. Moser, "Simulation of a multiple-nozzle diffuser", Proceedings of the 12th AIVC Conference on Air Movement and Ventilation control within Buildings, Ottawa, Canada, Vol. 2, 1-13, 1991.
5. J. Heikkinen, "Modelling of a supply air terminal for room air flow simulation", Proceedings of the 12th AIVC Conference on Air Movement and Ventilation control within Buildings, Ottawa, Canada, Vol. 3, 213-230, 1991.
6. J. R. Fontaine, F. Biolley, R. Rapp, J. C. Sérieyss and J. C. Cunin, "Analysis of a three-dimensional ventilation flow: Experimental validation on a water scale model of numerical simulations", Numerical Heat Transfer, Part A, Vol. 26, 431-451, 1994.

**Table 1** Boundary conditions for the experiments with a heated surface. In the equation for the Archimedes number  $a_0$  is the effective inlet area and  $u_0$  is the corresponding inlet velocity.

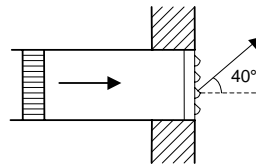
Airflow rate (m <sup>3</sup> /h)	Inlet temperature $t_0$ (°C)	Return temperature $t_R$ (°C)	Flux from heated surface (W)	Archimedes number $Ar = \frac{\beta g \sqrt{a_0} (t_R - t_0)}{u_0^2}$
113.4	15.0	20.1	275	0.0011



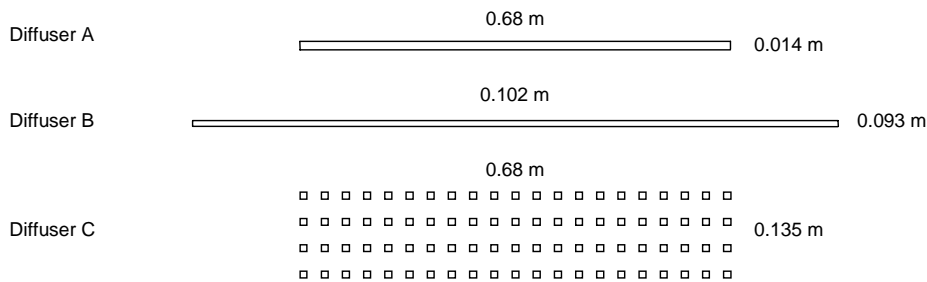
**Figure 1** Outline of the full-scale room. The inlet diffuser and the return opening are located at the lower x wall. On the opposite end wall a heated surface is introduced in some of the cases.



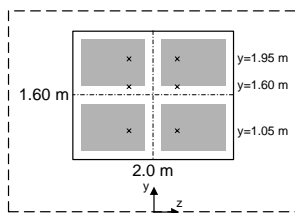
**Figure 2** The diffuser consists of 84 nozzles with ( $d=12$  mm).



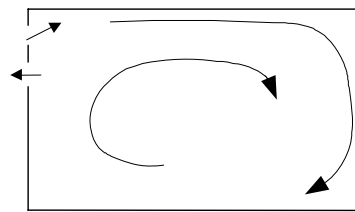
**Figure 3** The inlet diffuser supplies air at  $40^\circ$  to horizontal.



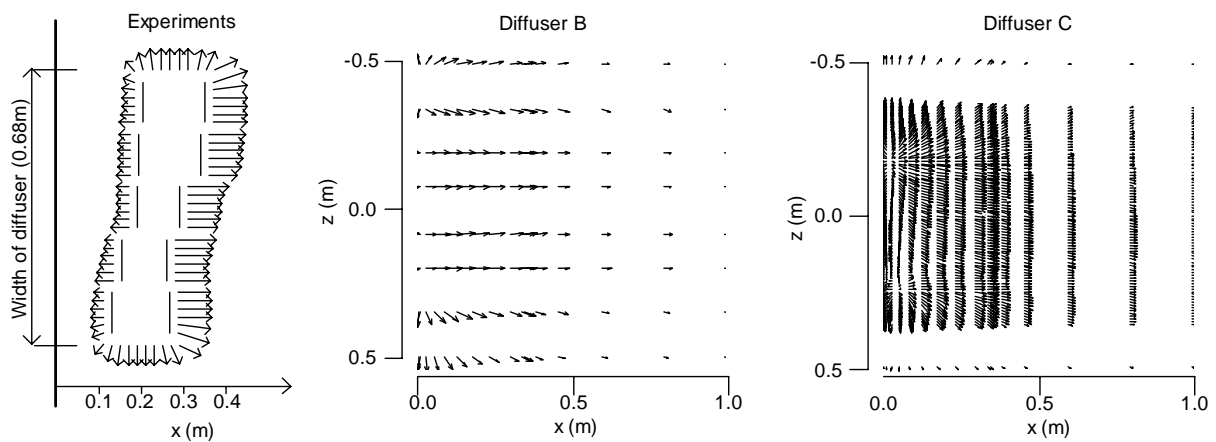
**Figure 4** Outline of the three different geometric simplifications of the inlet diffuser.



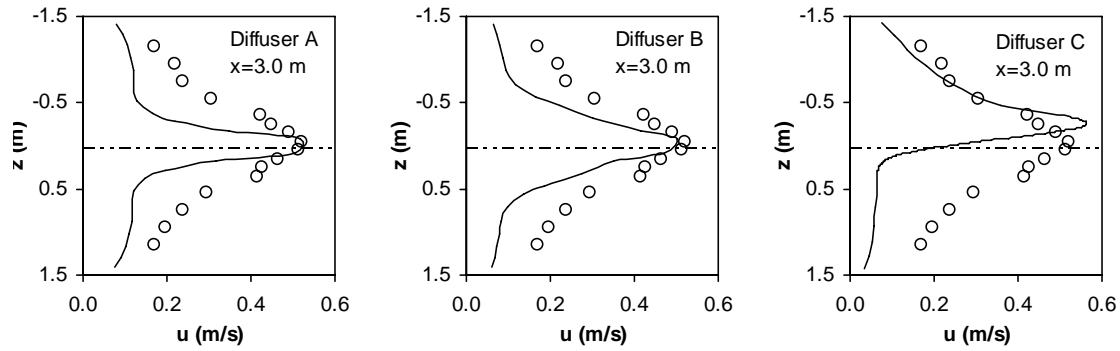
**Figure 5** The heated surface consists of four panels heated by an electrical current. Horizontal velocity profiles were measured at 6 different locations (marked by x).



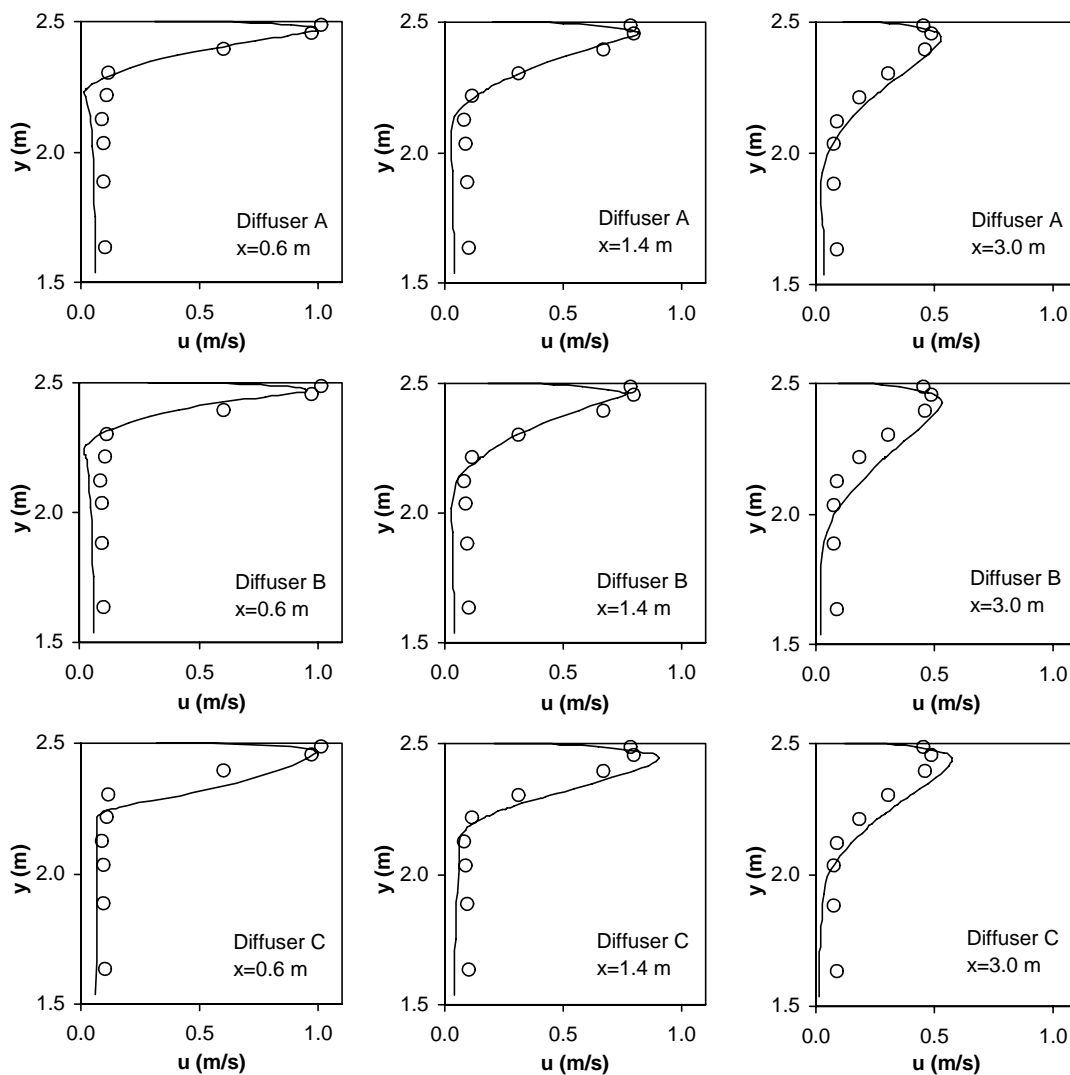
**Figure 6** Observed flow pattern in the full-scale experiments. When the heated surface was introduced the velocity level in the flow along the end wall was reduced due buoyancy.



**Figure 7** Illustration of horizontal flow pattern near the diffuser from experiments and diffuser model B and C.

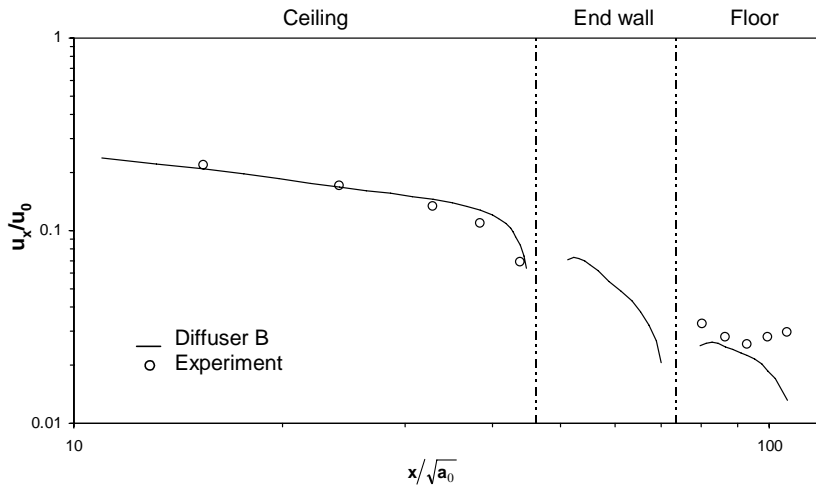


**Figure 8** Horizontal velocity profiles for the three diffuser models (line) compared to experiments (O) at  $x=3.0$  m and  $y=2.455$  m.

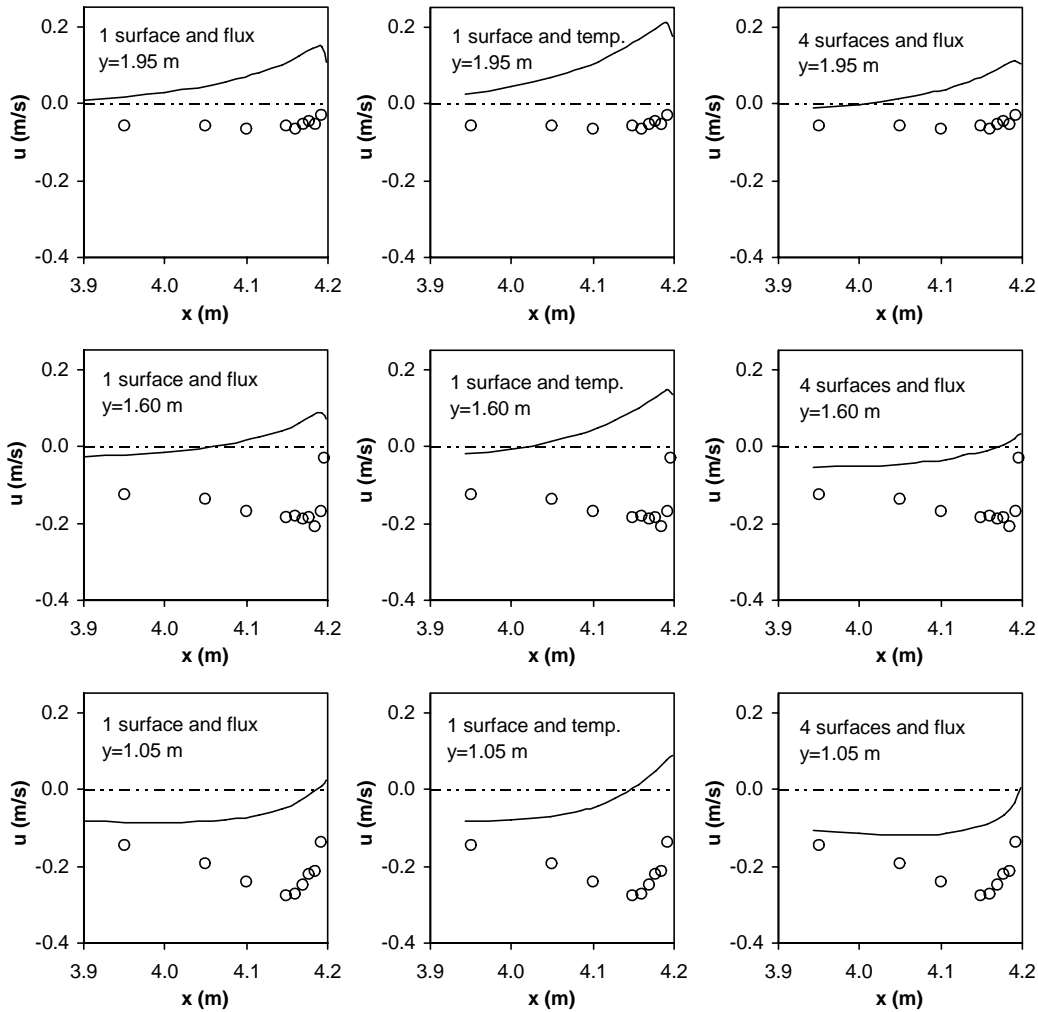


**Figure 9** Vertical velocity profiles in the jet centreline for the diffuser models (line) compared to experiments (O) at different  $x$  stations. The jet centreline for diffuser C is not identical to the room centreline due to jet asymmetry.





**Figure 10** Velocity decay in the recirculating flow for diffuser B (line) compared to experimental results (O).  $u_x$  is the maximum velocity at position  $x$ ,  $u_0$  is the inlet velocity,  $x$  is the position and  $a_0$  is the effective inlet area.



**Figure 11** Velocity profiles near the heated surface. The profiles shown are the average profiles at a given  $y$  position from experiments (O) and corresponding CFD results (line). Positive velocities indicate an upward flow.