



**AALBORG UNIVERSITY**  
DENMARK

**Aalborg Universitet**

## **Active Vibration Control of a Monopile Offshore Structure**

Nielsen, Søren R. K.; Kirkegaard, Poul Henning; Thesbjerg, L.

*Published in:*  
Proceedings of "Dynamics of Structures"

*Publication date:*  
1996

*Document Version*  
Publisher's PDF, also known as Version of record

[Link to publication from Aalborg University](#)

*Citation for published version (APA):*  
Nielsen, S. R. K., Kirkegaard, P. H., & Thesbjerg, L. (1996). Active Vibration Control of a Monopile Offshore Structure. In Proceedings of "Dynamics of Structures": 2nd workshop on dynamic loads and response of structures and soil dynamics, November 13-14, 1996, Aalborg University, Denmark (pp. 90-101). Aalborg: Dept. of Building Technology and Structural Engineering, Aalborg University.

### **General rights**

Copyright and moral rights for the publications made accessible in the public portal are retained by the authors and/or other copyright owners and it is a condition of accessing publications that users recognise and abide by the legal requirements associated with these rights.

- ? Users may download and print one copy of any publication from the public portal for the purpose of private study or research.
- ? You may not further distribute the material or use it for any profit-making activity or commercial gain
- ? You may freely distribute the URL identifying the publication in the public portal ?

### **Take down policy**

If you believe that this document breaches copyright please contact us at [vbn@aub.aau.dk](mailto:vbn@aub.aau.dk) providing details, and we will remove access to the work immediately and investigate your claim.

## Active Vibration Control of a Monopile Offshore Structure

S.R.K. Nielsen & P.H. Kirkegaard  
Aalborg University

Department of Building Technology and Structural Engineering  
Sohngaardsholmsvej 57  
DK-9000 Aalborg, Denmark

&

Leo Thesbjerg  
Rambøll A/S , Esbjerg

### Abstract

In the Danish part of the North Sea it has been found that marginal fields can be exploited using monopile offshore platforms which present significant advantages with respect to the costs involved in fabrication and installation and can therefore tip the economic balance favourably. Monopile platforms have been developed for approximately 35 m water depth and to be remotely operated. However, there has recently been a wish to use the monopile concept on 75 m water depth. Using monopiles in such water depths can imply significantly dynamic problems. Therefore, in order to reduce the vibrations, it can be necessary to use an active or a passive vibration control system. However, for a monopile with severe space problems it can be difficult to locate a passive control system such as e.g. a tuned mass damper. Therefore, in order to active control wave introduced vibrations of a monopile structure an active control technique has been proposed in corporation with the consulting company Rambøll, Esbjerg, Denmark. The proposed control technique is based on the relationship between the position of the separation points of the boundary layer flow and the drag term in the wave force on the cylinder. This concept has been experimentally investigated with a test model in stationary flow tests. The idea is to have a large drag coefficient when the cylinder moves opposite of the wave direction implying a relatively large damping excitation. When the structure moves in the wave direction a small drag coefficient should be obtained in order to have a relatively small excitation on the cylinder. The drag coefficient can be controlled if the separation points of the boundary layers can be controlled. It is proposed to control the separation points by blowing compressed air out of the holes in the cylinder. If the natural separation points of the boundary layers are rejected by blowing air out of the holes the drag coefficient will increase while it will decrease if it is possible to attach the boundary layer. The results from the experimental test have shown that it is possible to increase the drag coefficient with a factor 1.5-2 by blowing air out of the holes in a cylinder vibrating in a stationary water flow.

## 1. INTRODUCTION

Many of the oil fields discovered in the North Sea are marginal fields. Furthermore, the layers in which the reservoirs are located may have very small permeability. Consequently, it is very difficult to predict the production rate for these fields. To develop this type of oil fields it is necessary to minimize the initial investments in the field in order to limit the consequences of a production smaller than predicted. This can be accomplished by means of a smaller remotely operated installation with provision for only one or a few wells.

In the Danish part of the North Sea it has been found that marginal fields can be exploited using monopile offshore platforms, see figure 1, which present significant advantages with respect to the costs involved in fabrication and installation and can therefore tip the economic balance favourably.

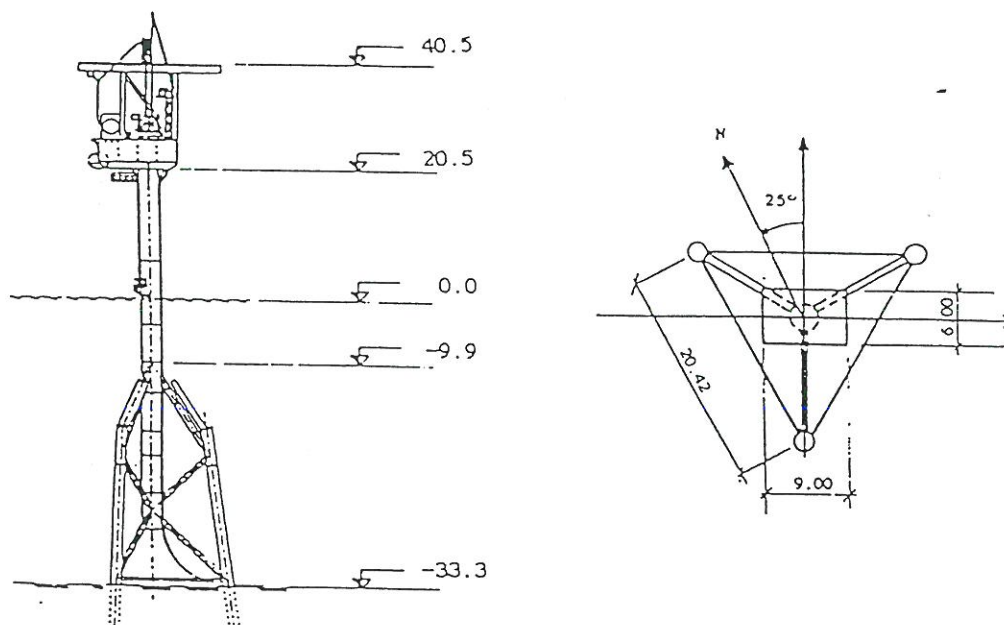

Figure 1: Elevation of a monopile offshore structure used in the Danish part of the North Sea.

The monopile platform shown in figure 1 was developed for approximately 35 m water depth and was remotely operated. This means that in 35 m water depth the free standing structure is governed by its dynamic behaviour and thus prone to fatigue. However, since the structure is remotely operated comfort criteria can be neglected in the design phase. The monopile design has been found not to be governed by the extreme storm load case, but more significantly influenced of fatigue life.

Recently, there has been a wish to use the monopile concept on 75 m water depth. Using monopiles in such water depths can imply significantly dynamic problems. Therefore, in order to reduce the vibrations, it can be necessary to use an active vibration control system. Active vibration control of civil engineering structures can be done using different techniques, see e.g. Soong et al. [1] and Thesbjerg [2]. Active control implies an external excitation in order to obtain a vibration suppression of a structure which is dynamically loaded. Active control is an alternative to passive control which has been seriously considered during the last 50 years.

Passive control implies an arrangement which can reduce the response of the structure. The general subject concerning active control of dynamic systems has been studied longer than active control of civil engineering structures. For many decades, the basic concepts of active control have been the staple of electrical and control engineering and they have been applied successfully in a variety of disciplines, such as aerospace engineering and mechanical engineering.

In order to reduce the vibrations of a monopile structure passive control techniques can be used, e.g. a tuned mass damper, see Soong et al. [1]. However, for a monopile with severe space limitation it can be difficult to locate a tuned mass damper.

In order to active control wave introduced vibration of a monopile structure a control technique has been proposed in corporation with the consulting company Rambøll, Esbjerg, Denmark.

The proposed control technique is based on the relationship between the boundary layer flow and the drag term in the wave force on the structure. It is well known that the wave force consists of a drag term and an inertia term. Normally, the drag term can be estimated using a so-called drag coefficient approximately equal to 0.6 for a cylinder. However, this drag coefficient is a function of the geometry of the structure, but the drag coefficient also depends on the separation points of the boundary layers. This means that the drag coefficient can be controlled if the separation points of the boundary layers can be controlled. One way to control these points could be to perforate the structure and blow air out of the holes. How this concept can be used to reduce the vibrations is explained in the following section.

## 2. THEORY

This section outlines how the vibrations of a monopile offshore structure can be reduced by controlling the boundary layer separation points. Further, the mathematical model which has been used to experimentally investigate the idea is given.

### 2.1 Relationship between Vibrations and Wave Force

It is well known that the force on a vertically placed cylinder subjected to wave action consists of a drag  $f_D$  as well as an inertia  $f_I$  component, see e.g. Sarpkaya et al.[3]. It is generally assumed that the total wave force per unit length of a fixed vertical cylinder of the diameter  $D$  is

$$f = f_D + f_I = \frac{1}{2}C_D\rho D|\dot{u} - \dot{v}|(\dot{u} - \dot{v}) + \frac{\pi}{4}C_M\rho D^2\ddot{u} - (C_M - 1)\frac{\pi}{4}\rho D^2(\ddot{v}) \quad (1)$$

where  $\dot{u}$  and  $\ddot{u}$  and  $\dot{v}$  and  $\ddot{v}$  are the velocity and the acceleration of the fluid and the structure, respectively.  $C_D$  and  $C_M$  are the drag and inertia coefficients, respectively.  $\rho$  is the density of water.

The idea of the active vibration control system proposed in this research relies on changes in the drag term. Normally, the drag term can be estimated using a drag coefficient approximately equal to 0.6 for a cylinder. However, this drag coefficient is a function of the geometry of the structure, but the drag coefficient also depends on the position of the separation points of the boundary layers. This means that the drag coefficient can be controlled if the position of the separation points of the boundary layers can be controlled. One way to control these points could be to perforate the structure and blow air out of the holes. If the boundary layers are forced to separate

by blowing air out of the holes the drag coefficient will increase. This is the opposite of the well-known principle that the drag force can be reduced by suction. The idea is now to have a large drag coefficient when the cylinder moves opposite of the wave direction, see figure 2a, implying a relatively large damping excitation. When the structure moves in the wave direction a small drag coefficient should be obtained in order to have a relatively small excitation on the cylinder, see figure 2b.

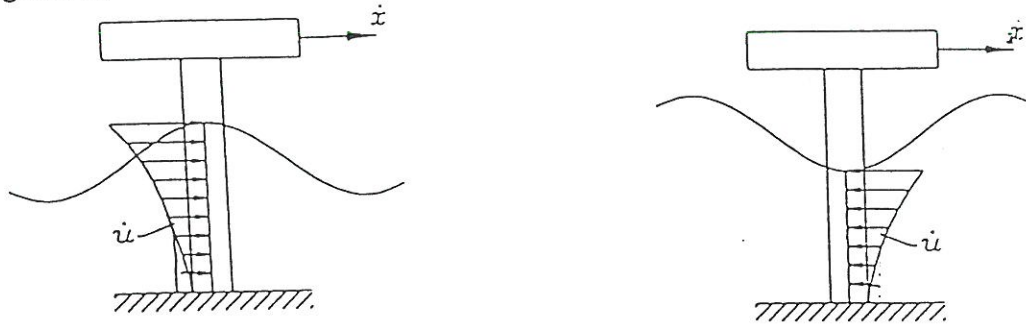

Figure 2a: Wave velocity  $u$  and cylinder velocity in opposite direction      2b: Wave velocity and cylinder velocity in same direction

### 2.2 Mathematical Model

The following model was proposed to be used in an experimental investigation of the change in drag coefficient as a function of air blown out of the holes in a cylinder vibrating in a stationary flow.

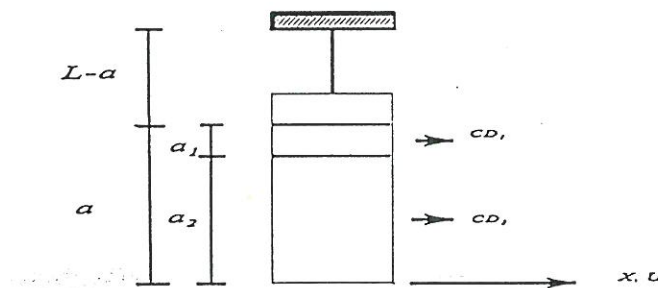

Figure 3: Definition of parameters in mathematical model of a monopile offshore structure

A test model consisting of a steel cylinder has been made as explained in section 3. This model is tested in a stationary flow with the velocity  $\dot{U}$ .  $L$  and  $a$  are the distances from the bottom of the cylinder to the beam where the model is attached and water level, respectively. The cylinder is perforated from water level and to  $a_1$  under water level. It is assumed that the force on the structure now can be estimated using two drag coefficients.  $C_{D_1}$  is the drag coefficient or the area where the cylinder is perforated and  $C_{D_2}$  is the drag coefficient or the area where the cylinder is

not perforated. The model is assumed to be described using one degree-of-freedom which is selected as the displacement  $x$  of the cylinder bottom. The eigenmode is a linearly varying function, so  $v(z,t) \approx x(t)z/L$  where  $z$  is a vertical coordinate. This means that the governing differential equation for the model in figure 3 can be written in the following way using (1) with  $\dot{u}(z,t) = \dot{U}(t)$  and  $\ddot{u}(z,t) = \ddot{U}(t)$ , i.e the flow is independent of  $z$

$$m_s(\ddot{x} + 2\zeta_0\omega_0\dot{x} + \omega_0^2x) = C_{D_1}\frac{1}{2}\rho DLf_0\left(1-\frac{a}{L},1-\frac{a_2}{L},\dot{U},\dot{x}\right) + C_{D_2}\frac{1}{2}\rho DLf_0\left(1-\frac{a_2}{L},1,\dot{U},\dot{x}\right) - m_h\ddot{x} + m_1\ddot{U} \quad (2)$$

where  $\omega_0$  and  $\zeta_0$  are the frequency and damping ratio of the system, respectively. The structural mass  $m_s$ , the modal hydrodynamic mass  $m_h$  and the induced mass  $m_1$ , respectively are given by

$$m_s = \int_0^L \mu(z) \left(\frac{z}{L}\right)^2 dz, \quad m_h = \frac{\pi}{4}(C_M-1)\rho D^2 \int_{L-a}^L \left(\frac{z}{L}\right)^2 dz, \quad m_1 = \frac{\pi}{4}C_M\rho D^2 \int_{L-a}^L \left(\frac{z}{L}\right) dz \quad (3)$$

The function  $f_0(\alpha,\beta,\dot{U},\dot{x})$  is given by

$$f_0(\alpha,\beta,\dot{U},\dot{x}) = \int_{\alpha}^{\beta} \xi |\dot{U} - \dot{x}\xi| (\dot{U} - \dot{x}\xi) d\xi \quad (4)$$

which can be analytically calculated as (where  $\eta = \frac{\dot{x}}{\dot{U}}$ )

$$f_0(\alpha,\beta,\dot{U},\dot{x}) = \frac{\dot{U}|\dot{U}|}{12} \begin{cases} 6(\beta^2 - \alpha^2) - 8(\beta^3 - \alpha^3)\eta + 3(\beta^4 - \alpha^4)\eta^2, & \infty < \eta \leq \frac{1}{\beta} \\ \frac{2}{\eta^2} - 6(\beta^2 + \alpha^2) + 8(\beta^3 + \alpha^3)\eta - 3(\beta^4 + \alpha^4)\eta^2, & \frac{1}{\beta} < \eta \leq \frac{1}{\alpha} \\ -6(\beta^2 - \alpha^2) + 8(\beta^3 - \alpha^3)\eta - 3(\beta^4 - \alpha^4)\eta^2, & \frac{1}{\alpha} < \eta \leq \infty \end{cases} \quad (5)$$

$$f_0(\alpha,\beta,0,\dot{x}) = -\frac{1}{4}(\beta^4 - \alpha^4)\dot{x}|\dot{x}| \quad (6)$$

### 3. DESCRIPTION OF TEST MODEL AND INSTRUMENTATION

The model presented in figure 3 was produced and instrumentated as described in this section.

#### 3.1 Model used in Experimental Investigations

Figures 4 and 5, respectively, show pictures of the produced test model. The model consists of a 0.5 m high steel cylinder with a diameter of 0.16 m which is closed in the bottom with a steel plate. The cylinder is mounted to a steel beam across the flow channel with a 0.16 m long, 0.03 m wide and 0.003 m thick steel plate. The cylinder is 0.2 and 0.24 m from the top of the cylinder perforated with 12 holes with equidistant distance, i.e. the cylinder is perforated with 24 holes. Compressed air can be blown out of these holes since each hole is connected with a rubber tubing. It is possible to open and close each rubber tubing with a valve. All the 24 valves are placed on a connection box which is connected to one high-pressure rubber tubing having a manometer and a valve. This implies that it is possible to regulate the pressure of the air submitted to the connection box and to the 24 rubber tubings.

#### 3.2 Instrumentation

The test programme was divided into two parts. The first part without water in the flow channel consisted of static tests to calibrate a strain gauge mounted on the steel plate which connects the steel cylinder to the beam across the flow channel. Further, some free decay tests without water in the flow channel were performed in order to estimate the structural parameters in equation (4). The second part of the test consisted of free decay tests with stationary water flow in the flow channel and different air pressure out of the holes in the cylinder. These tests were used to estimate  $C_{D_1}$  and  $C_{D_2}$  in (2). The flow was measured using an ultra sonic flow meter. The strain gauge signal and flow signal were both recorded using a data acquisition system based on a personal computer 386-40 MHz with an add-on A/D 16 bit simultaneous DT-2829 data acquisition board. The signal was sampled at 135 Hz with a time series length at 30 sec.

#### 3.3 Measurements Conditions

The tests were performed on December 22 and 23, 1995, in a 2-dimensional flow channel in the Hydraulics and Coastal Engineering Laboratory at Aalborg University, Sohngaardsholmsvej 57, DK-9000 Aalborg, Denmark. During the tests the water level was changing approximately  $\pm 0.01$  m. The water level  $a$  was 0.355 m and the distance  $a_2$  from the bottom of cylinder to the lowest holes in the cylinder was 0.238 m. The free decay tests were performed by giving the cylinder, using the hand, a deflection corresponding to approximately the same number of strains each time.

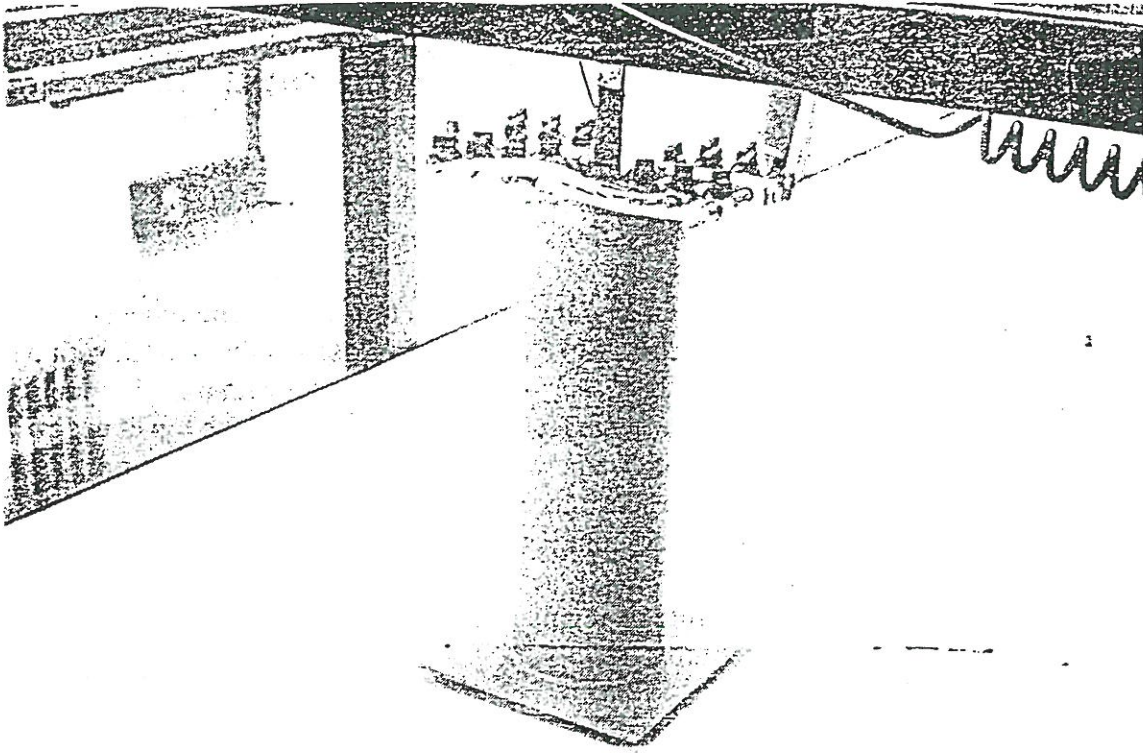

Figure 4. Picture of the monopile test model.

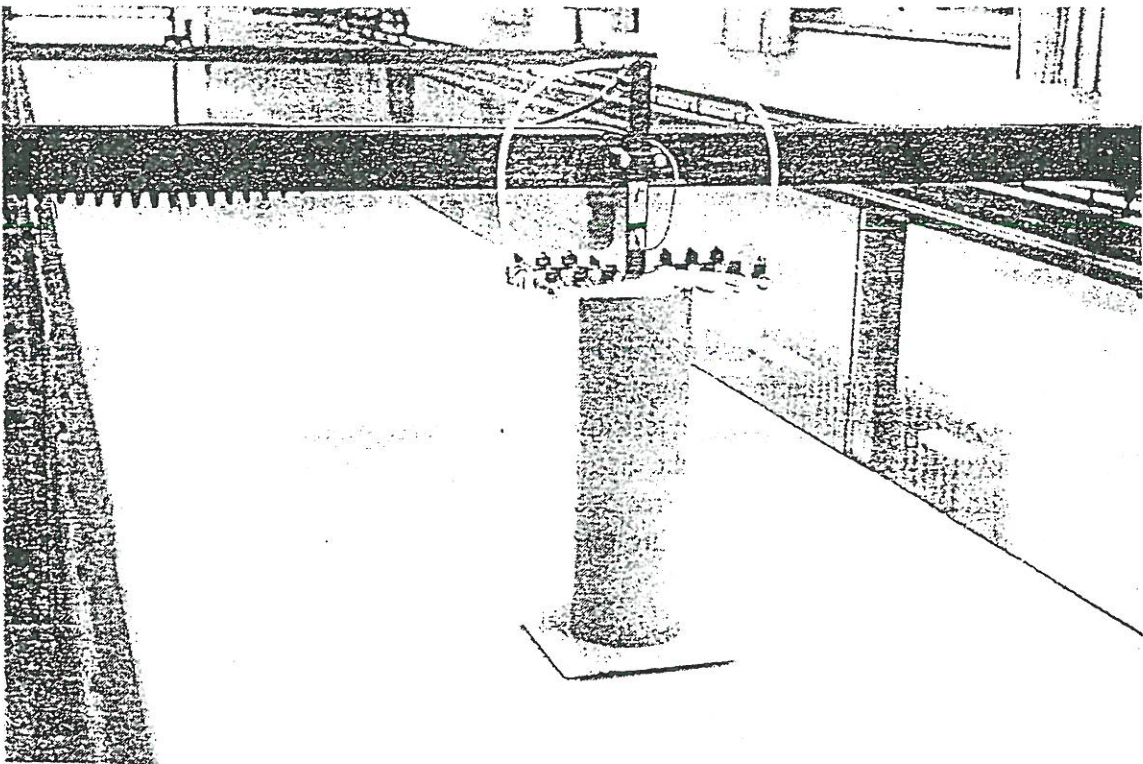

Figure 5. Picture of the monopile test model.



#### 4. RESULTS

In the following section the results will be presented and discussed. Section 4.1 describes the results performed to calibrate the strain gauge and the test model while section 4.2 presents the results from the test used to estimate  $C_{D_1}$  and  $C_{D_2}$  in (2).

##### 4.1 Estimation of Structural Parameters

In order to find the calibration factor between measured strains  $S$  and deflection  $x$  of the bottom of the test model and to find the stiffness of the system some static tests were performed. A string combined to a pulley and a plumb bob were connected to the bottom of the cylinder in the longitudinal direction of the flow channel. The results from a test where the weight of the plumb bob was  $PI$  were repeated five times and are shown in table 1

$PI$ (g)	$x$ (mm)	$S$ ( $\mu\epsilon$ )
0	0.00	-5
294.5	7.05	254
294.5 +294.7	14.28	502
0	0.11	0
294.5	7.01	247
294.5 +294.7	11.31	496
0	0.31	2
294.5	6.99	248
294.5 +294.7	14.24	496
0	0.22	-3
294.5	6.98	250
294.5 +294.7	14.33	501
0	0.01	-3
294.5	7.11	248
294.5 +294.7	14.35	495

Table 1: Static tests to calibration of strain gauge and estimation of stiffness.

From table 1 estimates of the calibration factor between strain and displacement are found. Further, the stiffness of the system is estimated. Next, 10 free decay tests without water in the flow channel and 8 tests with water in the flow channel were performed. These tests were performed in order to estimate the natural frequencies  $f_0$  and  $f_1$  of the system, respectively. The detrended time series were analysed using an Auto-Regressive model of order 6, see e.g. Pandit [4]. From the mean values of the natural frequencies results from tests without water flow in the channel the generalised mass was estimated as

$$m_s = \frac{k}{(2\pi f_0)^2} = 7.46 \text{ kg} \quad (7)$$

From (7) and the mean value of the natural frequencies results from tests with water flow in the channel the modal hydrodynamic mass  $m_h$  can now be estimated from the following relation as

$$m_h = k \left( \frac{1}{(2\pi f_1)^2} - \frac{1}{(2\pi f_0)^2} \right) = 7.96 \text{ kg} \quad (8)$$

#### 4.2 Estimation of $CD_1$ and $CD_2$

With the parameters estimated in section 4.2 the only unknowns in equation (2) are the drag coefficients  $C_{D_1}$  and  $C_{D_2}$ . Since the tests are performed in stationary flow the last term in equation (2) is equal to zero. In order to estimate the drag coefficients  $C_{D_1}$  and  $C_{D_2}$  the Extended Kalman Filtering technique was used, see e.g. Ljung [5] and Söderström [6]. It was decided to test the model blowing air with pressure  $p = \{0, 0.5, 1.0, 1.5, 2.5, 5.0\}$  bar out of the holes in the cylinder. Further, the tests were performed with some of the valves closed. Four different layout valve positions were selected. One layout with all valves opened, another with only 5 valves opened in each side of the cylinder and at last two layouts where the valves were open upstream and downstream, respectively. The relative changes of the drag coefficient estimates  $C_{D_1}^i$  are shown in figures 5 and 6, respectively, for the two different water flows. It is seen from these figures that a significant change of the drag coefficient can be obtained when air is blown out of the holes in the cylinder.

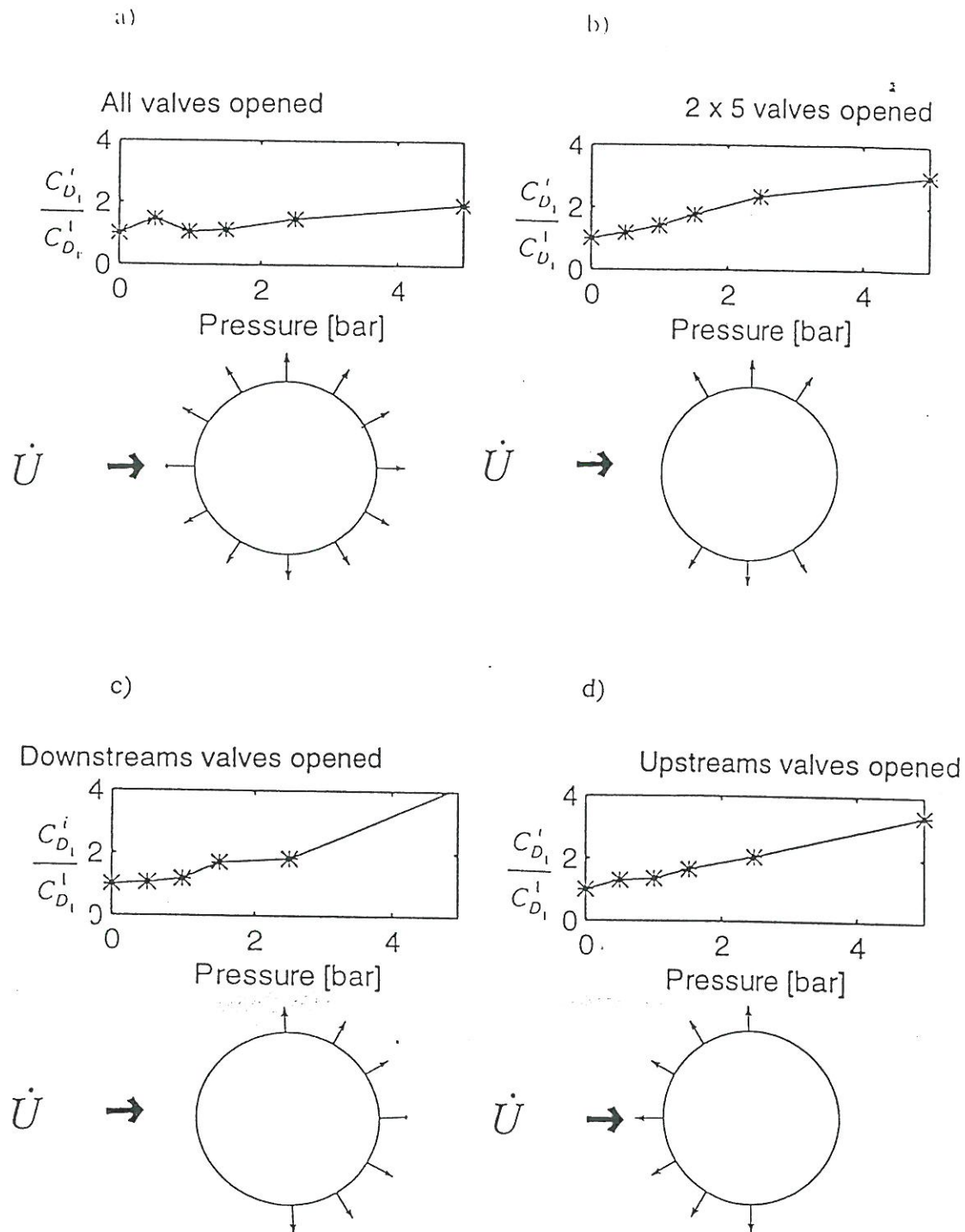

Figure 3: Relative changes in drag coefficients as a function of air pressure. a) All valves opened. b) 2 x 5 valves opened. c) Downstream valves opened. d) Upstream valves opened. ( $\dot{U} \approx 0.1 \text{ m/s}$ )

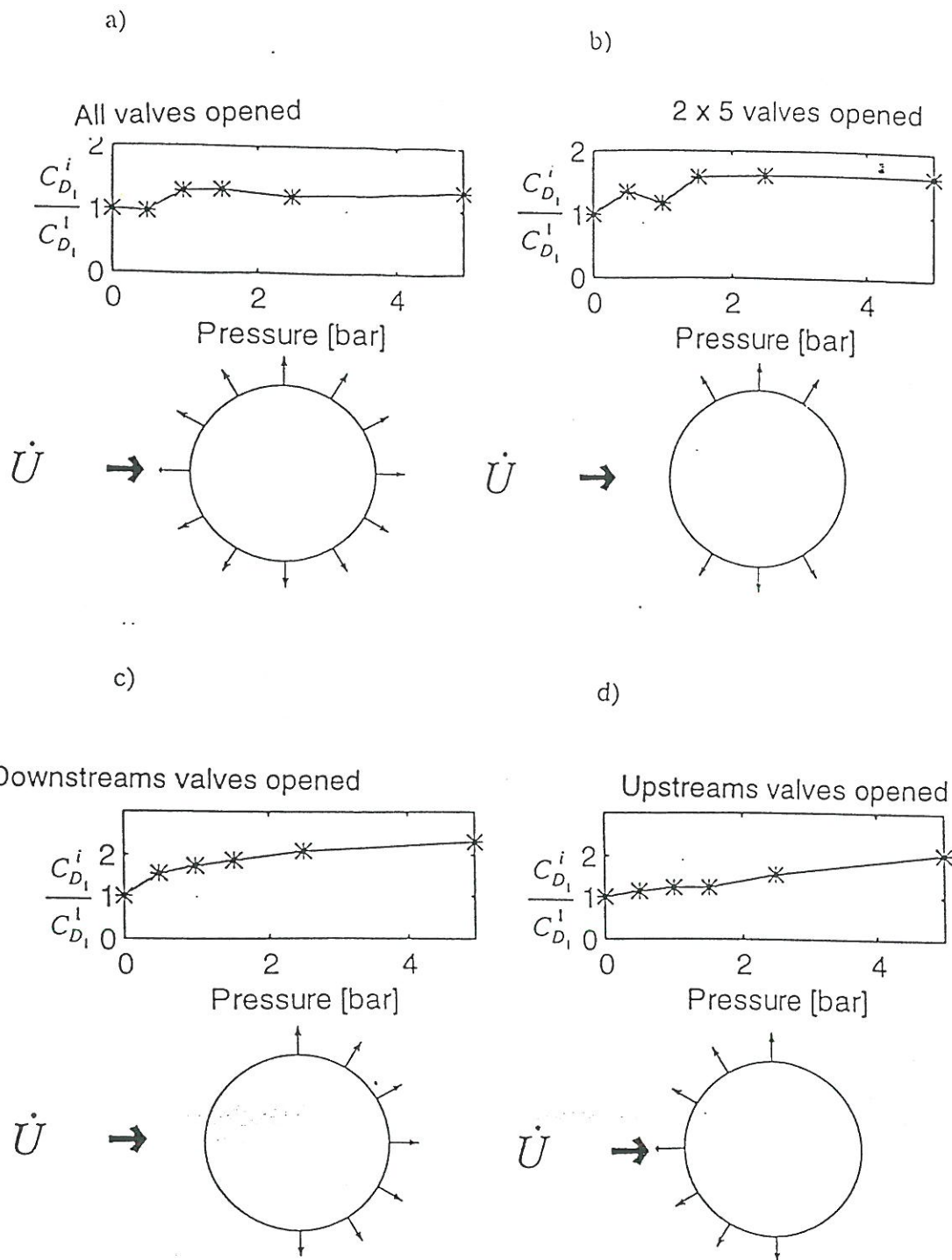

Figure 4: Relative changes in drag coefficients as a function of air pressure. a) All valves opened. b) 2 x 5 valves opened. c) Downstream valves opened. d) Upstream valves opened. ( $\dot{U} \approx 0.2 \text{ m/s}$ )

## 5. CONCLUSIONS

The results presented in the present report *Active Vibration Control of a Monopile Offshore Structure - Part One* show that it is possible to increase the drag coefficient with a factor 1.5-2 by blowing air out of the holes in a cylinder vibrating in a stationary water flow. This means that the proposed control technique based on the relationship between the position of the separation points of the boundary layer flow and the drag term in the wave force on the cylinder should be expected to work. However, before a final conclusion can be done, the test model should be tested in nonstationary water flow, i.e. in a test facility where it is possible to excite the model using waves. This will be the subject for research in the future.

## 6. ACKNOWLEDGEMENTS

The present research was partially supported by The Danish Technical Research Council within the project: "Dynamics of Structures".

## 7. REFERENCES

- [1] Soong, T.T.: *Active Vibration Control in Civil Engineering. State-of-the-Art, Eng. Structural, Vol.10, 1988.*
- [2] Thesbjerg, L: *Optimal Vibration Control of Civil Engineering Structures. Ph.D thesis, Structural Reliability Paper No. 93, Aalborg University, 1992*
- [3] Sarpkaya, T & M. Isaacson: *Mechanics of Wave Forces on Offshore Structures. Van Nostrand Reinhold Company, 1981.*
- [4] Pandit, S.M & S.M. Wu: *Time Series and System Analysis with Applications. John Wiley and sons, 1983.*
- [5] Ljung, L.: *System Identification - Theory for the User. Prentice Hall, Englewood Cliffs, 1987.*
- [6] Söderström, T. & P. Stoica: *System Identification. Prentice Hall, 1987.*