



AALBORG UNIVERSITY
DENMARK

Aalborg Universitet

Investigation of Airflow in a Room with displacement ventilation by means of a CFD-model

Jacobsen, T. V.; Nielsen, Peter Vilhelm

Publication date:
1994

Document Version
Publisher's PDF, also known as Version of record

[Link to publication from Aalborg University](#)

Citation for published version (APA):
Jacobsen, T. V., & Nielsen, P. V. (1994). *Investigation of Airflow in a Room with displacement ventilation by means of a CFD-model*. Dept. of Building Technology and Structural Engineering, Aalborg University. Gul Serie Vol. R9404 No. 20

General rights

Copyright and moral rights for the publications made accessible in the public portal are retained by the authors and/or other copyright owners and it is a condition of accessing publications that users recognise and abide by the legal requirements associated with these rights.

- ? Users may download and print one copy of any publication from the public portal for the purpose of private study or research.
- ? You may not further distribute the material or use it for any profit-making activity or commercial gain
- ? You may freely distribute the URL identifying the publication in the public portal ?

Take down policy

If you believe that this document breaches copyright please contact us at vbn@aub.aau.dk providing details, and we will remove access to the work immediately and investigate your claim.

INSTITUTTET FOR BYGNINGSTEKNIK

DEPT. OF BUILDING TECHNOLOGY AND STRUCTURAL ENGINEERING
AALBORG UNIVERSITETSCENTER • AUC • AALBORG • DANMARK

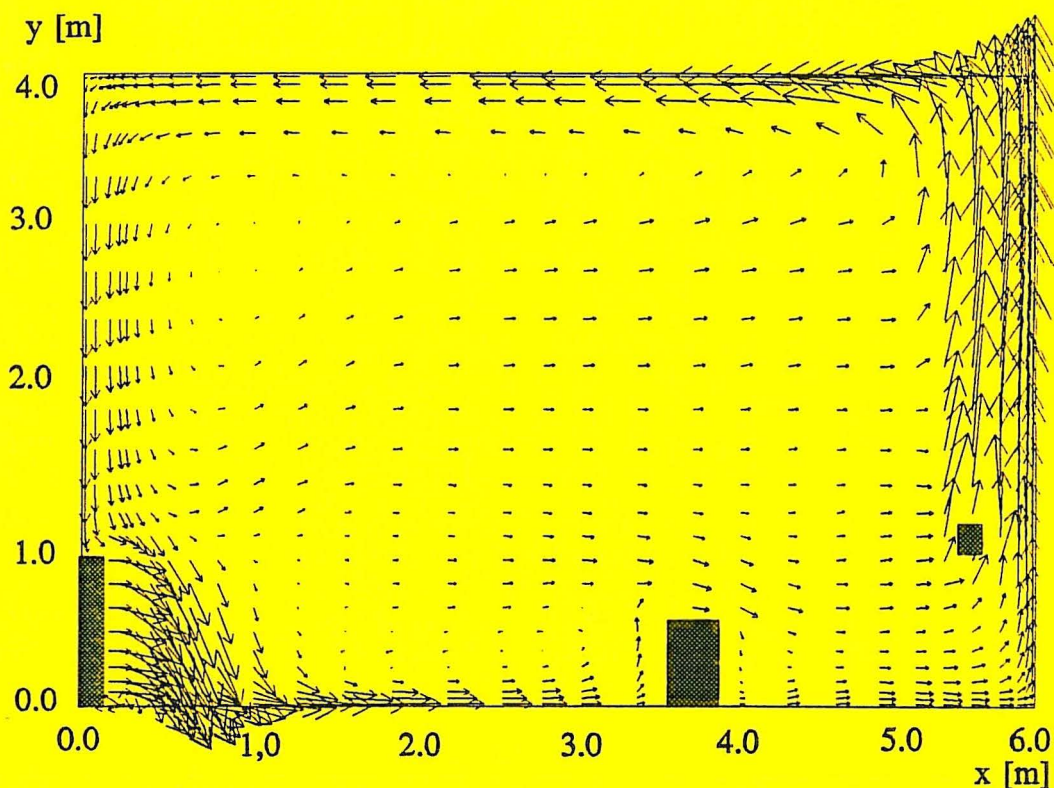

T. V. JACOBSEN & P. V. NIELSEN
INVESTIGATION OF AIRFLOW IN A ROOM WITH DISPLACEMENT
VENTILATION BY MEANS OF A CFD-MODEL
FEBRUARY 1994

ISSN 0902-7513 R9404

INSTITUTTET FOR BYGNINGSTEKNIK
DEPT. OF BUILDING TECHNOLOGY AND STRUCTURAL ENGINEERING
AALBORG UNIVERSITETSCENTER • AUC • AALBORG • DANMARK

T. V. JACOBSEN & P. V. NIELSEN
INVESTIGATION OF AIRFLOW IN A ROOM WITH DISPLACEMENT
VENTILATION BY MEANS OF A CFD-MODEL
FEBRUARY 1994 **ISSN 0902-7513 R9404**

Investigation of Airflow in a Room with Displacement Ventilation by Means of a CFD-Model

The airflow in front of an inlet device in a room with displacement ventilation is investigated in this study. In continuation of the full-scale measurements and the development of a CFD-model, described in /1/, this report aims at testing the model and conducting numerical experiments to provide a detailed description of the air current along the floor. It is investigated if the model results comply with a theoretical model.

Configuration of the room

The test room is equipped with an inlet device standing on the floor at the long wall. The heat sources are situated close to the opposite wall. 100 W is supplied to each of the two person simulators and 400 W is supplied to a small heat source standing on a table. Two exhaust openings are situated in the ceiling. The arrangement is assumed to create symmetrical flow in the two halves of the room.

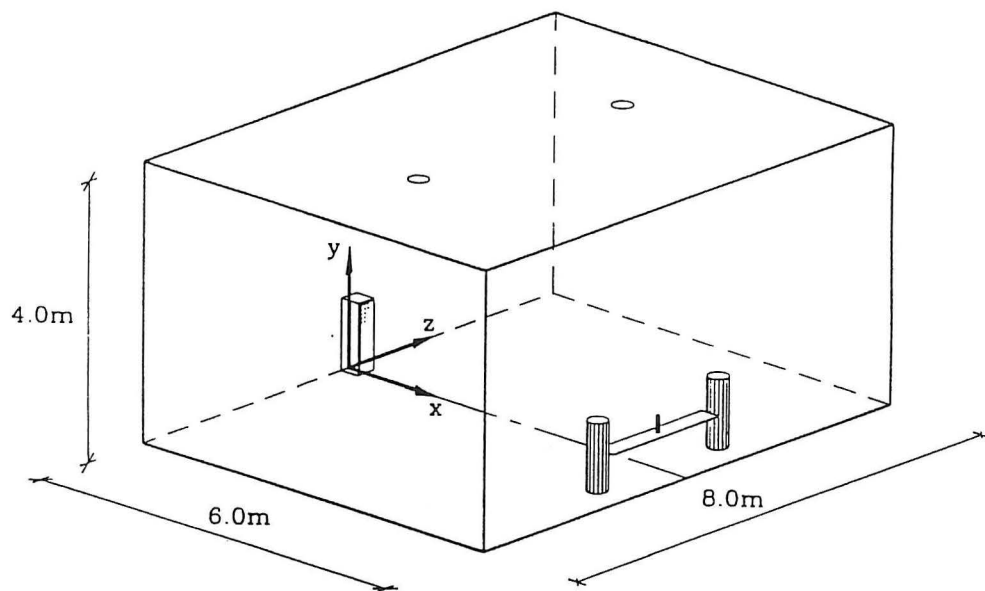

Figure 1.

CFD-model and boundary conditions

The CFD-model is based on the standard $k-\epsilon$ turbulence model. The Navier-Stokes equations are employed together with the continuity equation and transport/diffusion equations for relevant scalars. The set of variables includes the velocity components U, V and W for the x, y and z -directions, pressure, P , temperature, T , turbulent kinetic energy, k , and dissipation of turbulent kinetic energy, ϵ . The full governing equations can be found in /1/.

The governing equations are discretized using the HYBRID-scheme /2/ and for the results presented here a non-uniformly spaced computational grid of $n_x=33$, $n_y=26$ and $n_z=25$ has been applied.

Due to the assumption that a symmetrical flow prevails in the room, the calculations are restricted to only one half of the room. Boundary conditions corresponding to a symmetry plane are thus applied, implying that all variables at the grid nodes adjacent to the centre plane are specified in order to maintain gradients equal to zero.

Boundary conditions are specified at inlet, outlet, solid surfaces and heat sources.

Inlet: The inlet device is described as an obstacle and a uniform U-velocity profile is used at the inlet boundary. The inlet velocity is determined as $U_0=q_0/A_0$ and values of k and ϵ are equal to $1.1 \cdot 10^{-4} \text{ m}^2/\text{s}^2$ and $1.2 \cdot 10^{-5} \text{ m}^2/\text{s}^3$, respectively.

Outlet : The outlet serves to remove mass and heat. It is important that the demand for conservation of these properties is satisfied. The outlet velocity is found by dividing the supply air rate by the area of the outlet, $U_{\text{out}}=q_0/A_{\text{out}}$, and the outlet temperature is continuously checked throughout the calculation.

Solid surfaces: Traditional wall laws are applied in the momentum, k and ϵ equations /3/. A Discrete Transfer radiation model /4/ is used to take into account the radiative heat transfer between the surfaces of the room. Floor, ceiling and walls are assumed to be adiabatic and e.g. a radiative heat gain is transferred directly to the adjacent air volume.

Heat sources: To model the thermal plumes above the heat sources properly without spending too many grid nodes in the area close to the heat sources simplifications are needed. The surface temperatures of the heat sources are specified and the convective part of the heat transfer is calculated as the total supplied heat minus the radiative heat transfer.

Model of stratified airflow in front of the inlet device

The air in front of the inlet device spreads across the floor in an approximately radial pattern. The description of this type of flow is presented in /5/ and /6/. Figure 2 shows the initial angle of spreading, θ_0 , and at a distance from the inlet device where the stratified flow has been established the flow field is subdivided into angular sections, $\Delta\theta$. For each $\Delta\theta$ the airflow rate, $q_{\Delta\theta}$, at a distance, x , from the inlet device is found by integration across the vertical velocity profile, see ref. /6/:

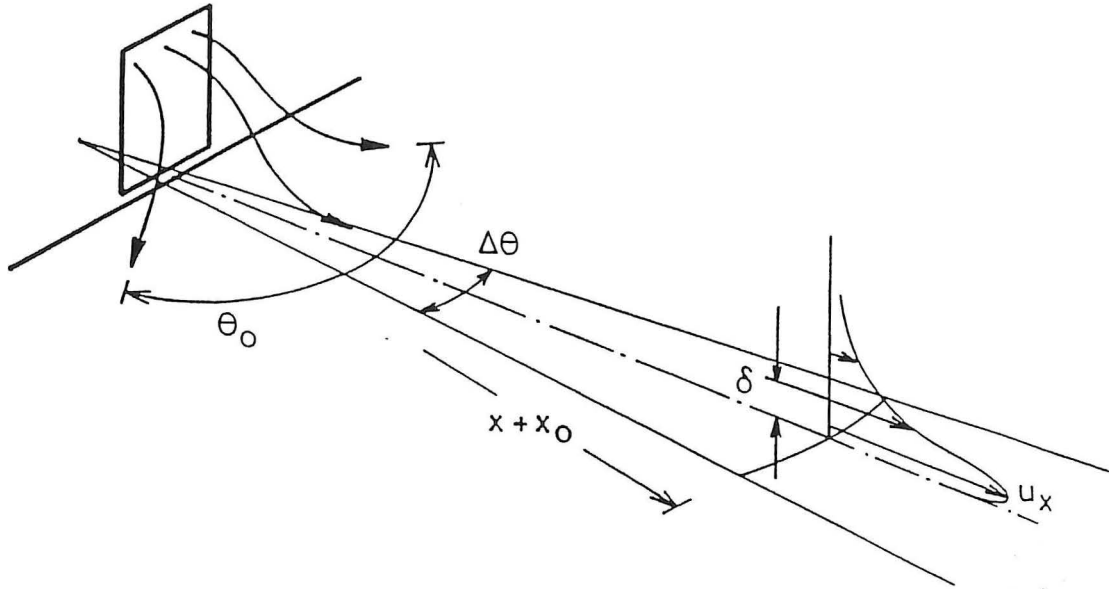

Figure 2.

$$q_{\Delta\theta} = \Delta\theta(x+x_0)\delta U_x \int_0^{\infty} f(\eta) d\eta \quad (1)$$

If the maximum velocity, U_x , and the layer thickness, δ , are assumed to be constant along the angle θ_0 , $q_{\Delta\theta}$ could also be expressed as :

$$q_{\Delta\theta} = \frac{\Delta\theta}{\theta_0} q_0 e \quad (2)$$

where e is entrainment. Eq.(1) is inserted in eq.(2).

$$\frac{U_x}{q_0} = \frac{e}{\theta_0 \delta \int_0^{\infty} f(\eta) d\eta} \frac{1}{x+x_0} \quad (3)$$

$$\frac{U_x}{q_0} = K_{\theta}(Ar) \frac{1}{x+x_0}, \quad K_{\theta}(Ar) = \frac{e}{\theta_0 \delta \int_0^{\infty} f(\eta) d\eta}$$

where e , θ_0 , δ and thus K are functions of the Archimedes number, Ar , see ref. /6/.

Measurements, however, indicate that the maximum velocities and the layer thickness often vary with the angle and they are consequently denoted U_{x_0} and δ_0 , respectively. An equation similar to eq.(3) is derived.

$$\frac{U_{x,\theta}}{q_0} = \frac{q_\theta \theta_0}{q_0} \frac{1}{\theta_0 \delta_\theta \int_0^\infty f(\eta) d\eta} \frac{1}{x+x_0}$$

↓

$$\frac{U_{x,\theta}}{q_0} = K_\theta(Ar) \frac{1}{x+x_0}, \quad K_\theta(Ar) = \frac{q_\theta}{q_0} \frac{1}{\delta_\theta \int_0^\infty f(\eta) d\eta}$$
(4)

Eq.(4) can thus be applied for the description in general of the dense air current along the floor.

Specification of test cases

Bearing in mind eq.(4) it is the purpose of the numerical experiments to describe how the Archimedes number influences the airflow. Furthermore, the variation of the flow field with the horizontal angle, θ , is investigated. The inlet flow rate has been altered to obtain different values of the reduced Archimedes number, Ar , in the range of 90 - 5400 °Cs²/m⁶. The disturbances of the flow field caused by placing a solid obstacle on the floor in the full width of the room are also investigated.

The model results given below show some interesting basic features of the displacement ventilation principle, but it should be emphasized that the numerical model may not be able to capture all important physical characteristics of the flow. Due to the complexity of the flow the model may have some shortcomings but the application of the CFD-model offers the possibility of avoiding time-consuming measurements.

References

- /1/ T.V. Jacobsen, Airflow and Temperature Distribution in Rooms with Displacement Ventilation, Ph.D.-Thesis, Dep. of Building Technology and Structural Engineering, Aalborg University 1993, ISSN 0902-7513 R9328.
- /2/ S.V. Patankar, Numerical Heat and Fluid Flow, McGraw-Hill, New York 1980.
- /3/ B.E. Launder & D.B. Spalding, The Computation of Turbulent Flows, Computational Methods of Applied Mechanical Engineering, vol. 3 1974.
- /4/ F.C. Lockwood & N.G. Shah, A New Radiation Solution Method for Incorporation in General Combustion Prediction Procedures, International Symposium on Combustion 1981.

- /5/ **P.V. Nielsen**, Velocity Distribution in the Flow from a Wall-Mounted Diffuser in Rooms with Displacement Ventilation, Proc. of ROOMVENT '92, Aalborg 1992.
- /6/ **P.V. Nielsen**, Velocity Distribution in a Room with Displacement Ventilation and Low-Level Diffusers, Internal Report, International Energy Agency, Energy Conservation in Buildings and Community Systems, Annex 20, ISSN 0902-7513 R9403, 1994.

Vector plots for different Archimedes numbers

$Ar_r = 5385, z=0.0m$

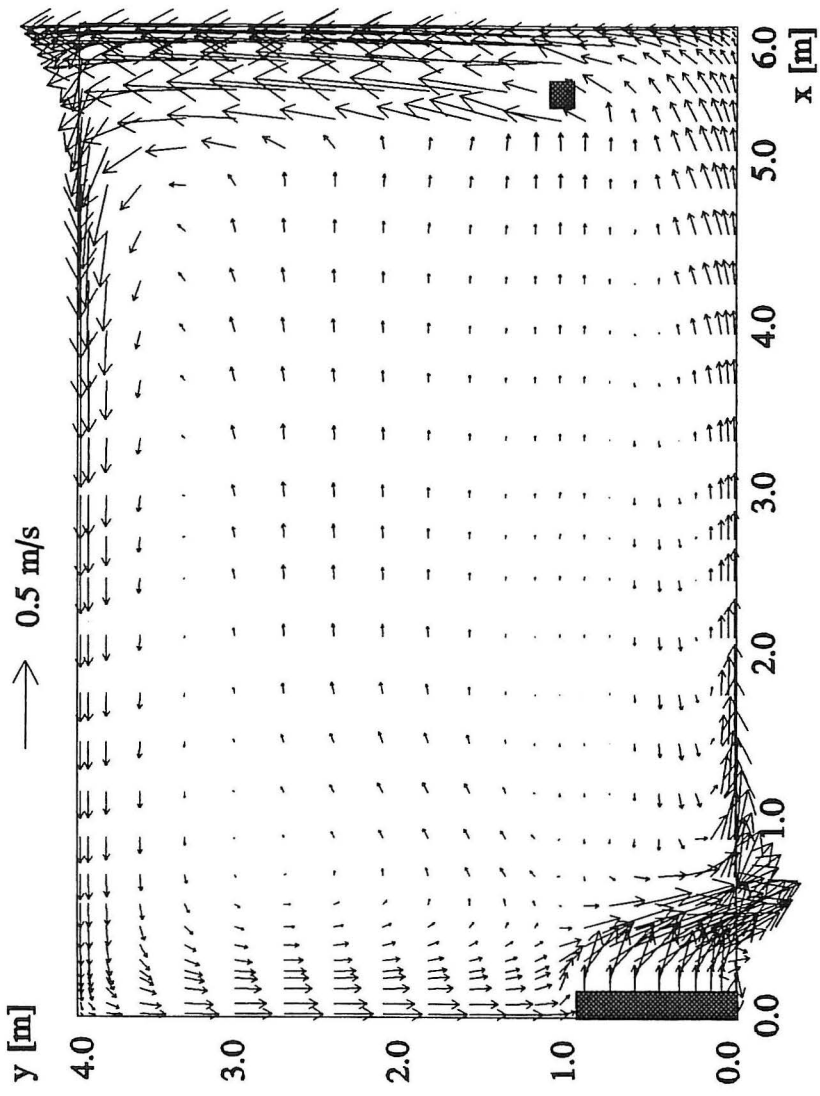

$Ar_r = 5385, y=0.03m$

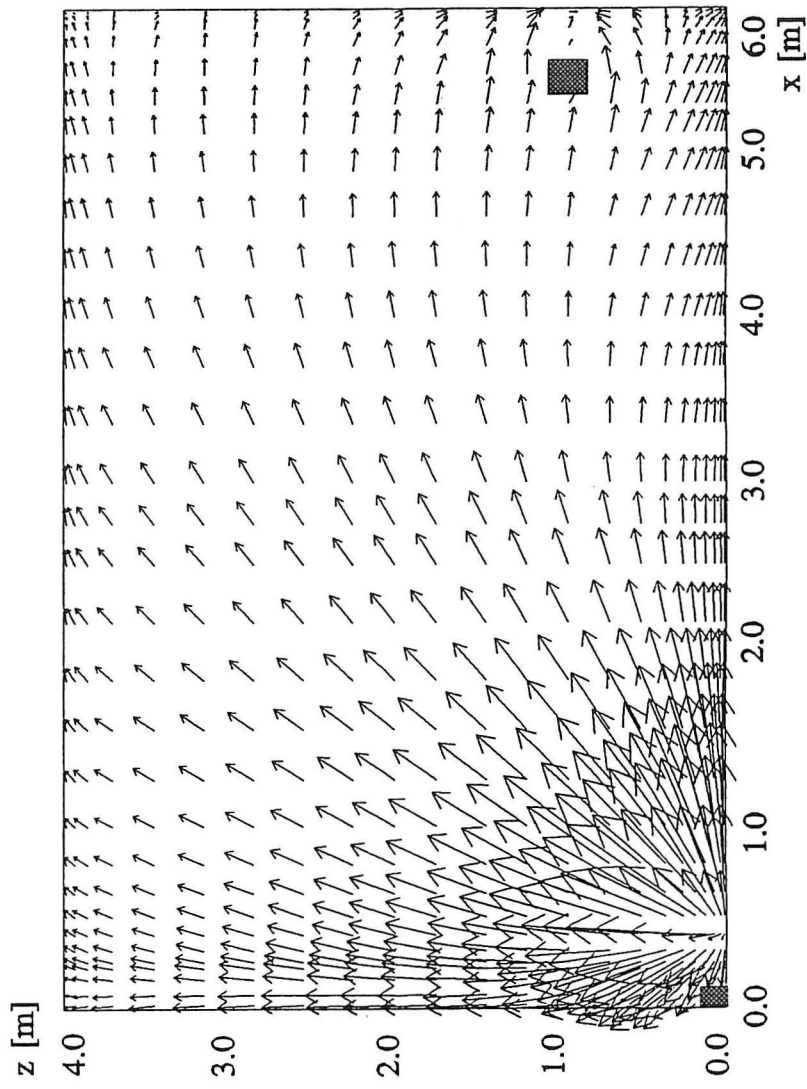

$Ar_r = 5385, z=4.0m$

y [m]

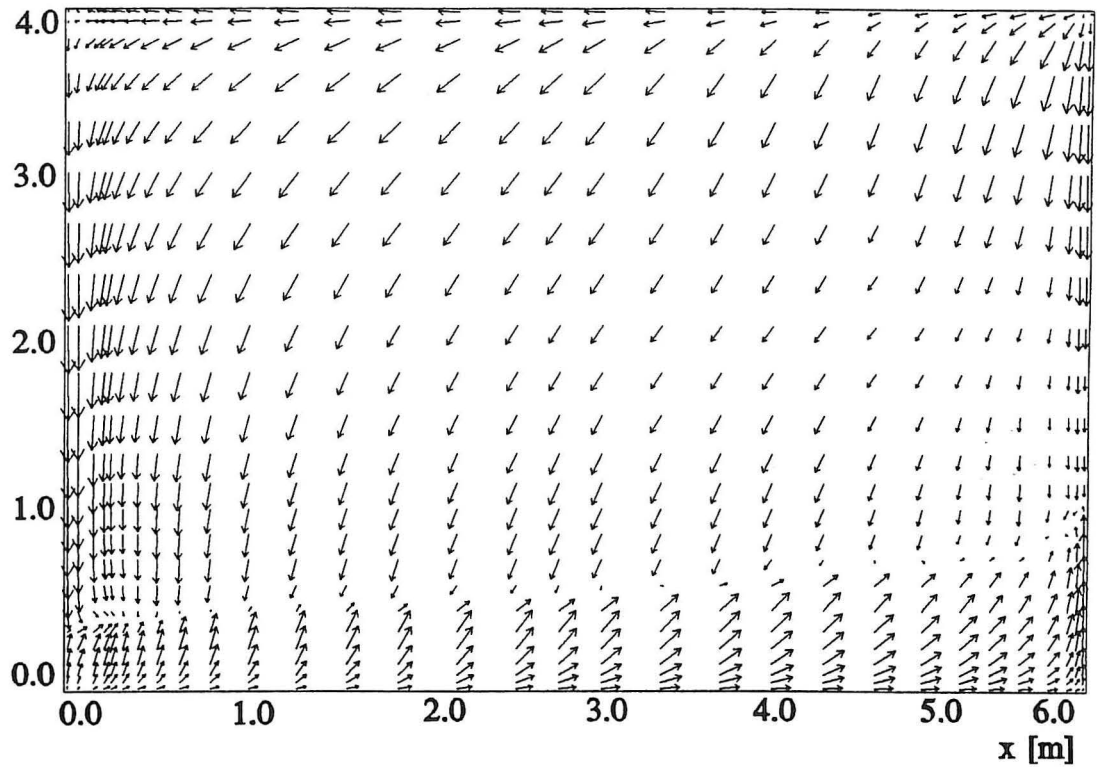

$Ar_r = 5385, x=6.0m$

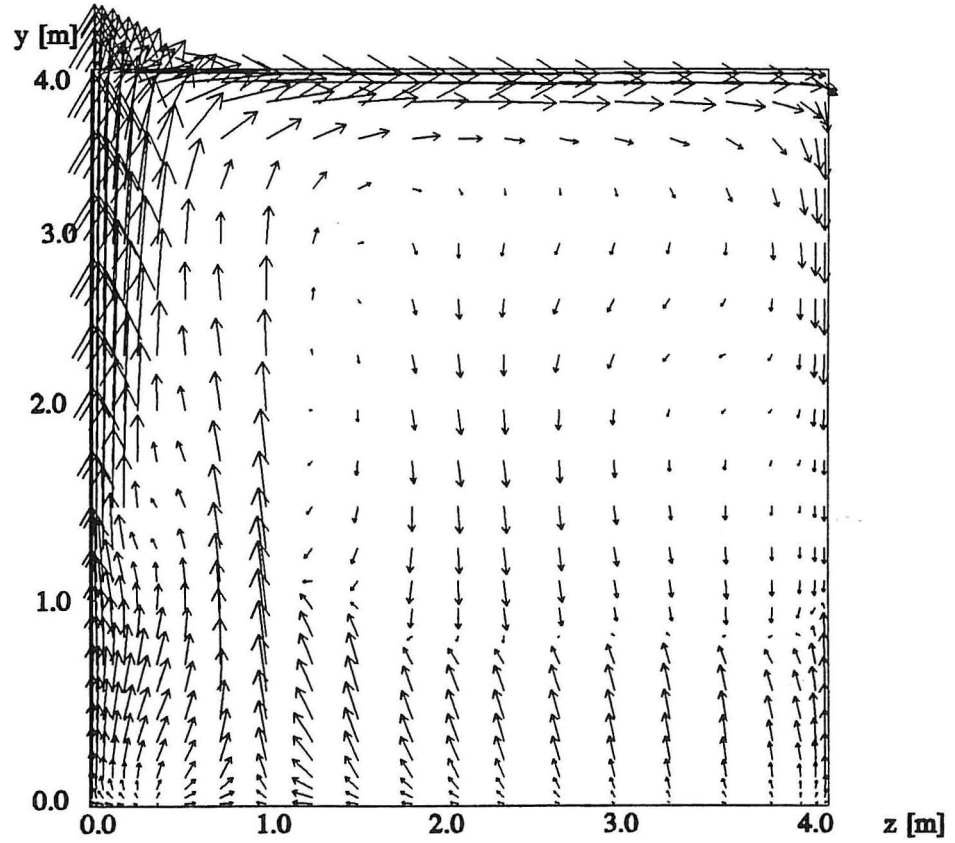

$Ar_r = 720, z=0.0\text{m}$

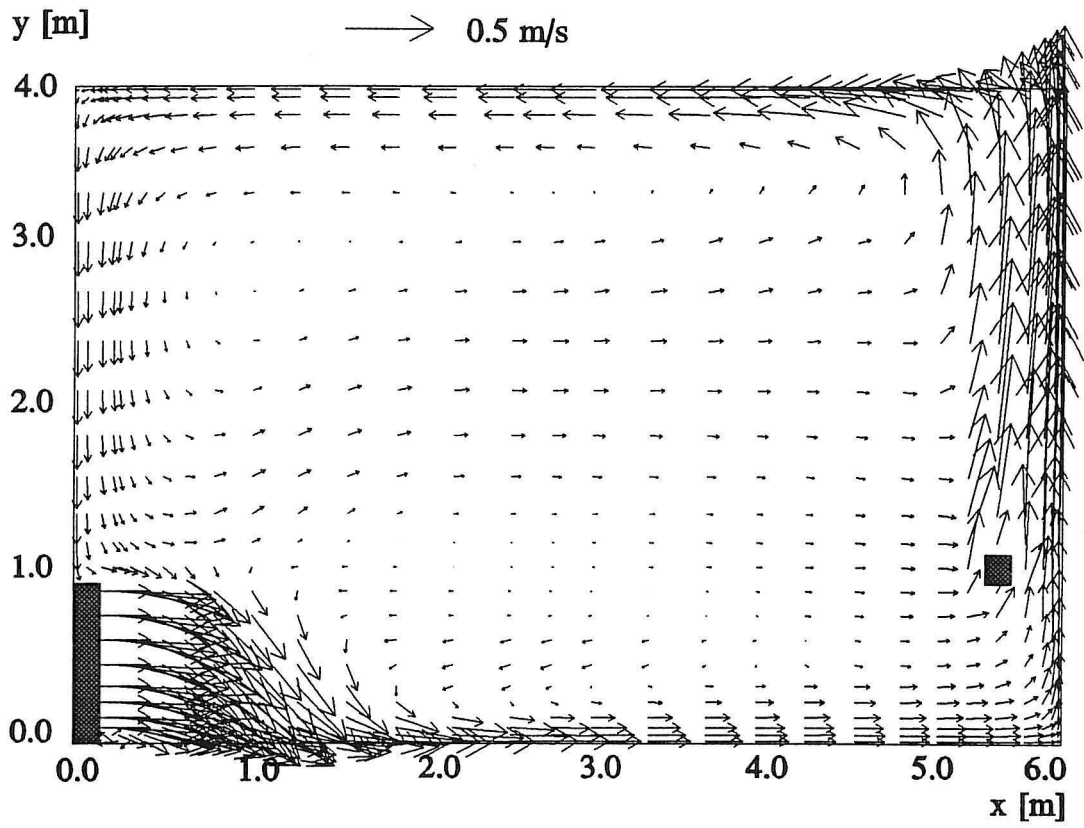

$Ar_r = 720, y=0.03\text{m}$

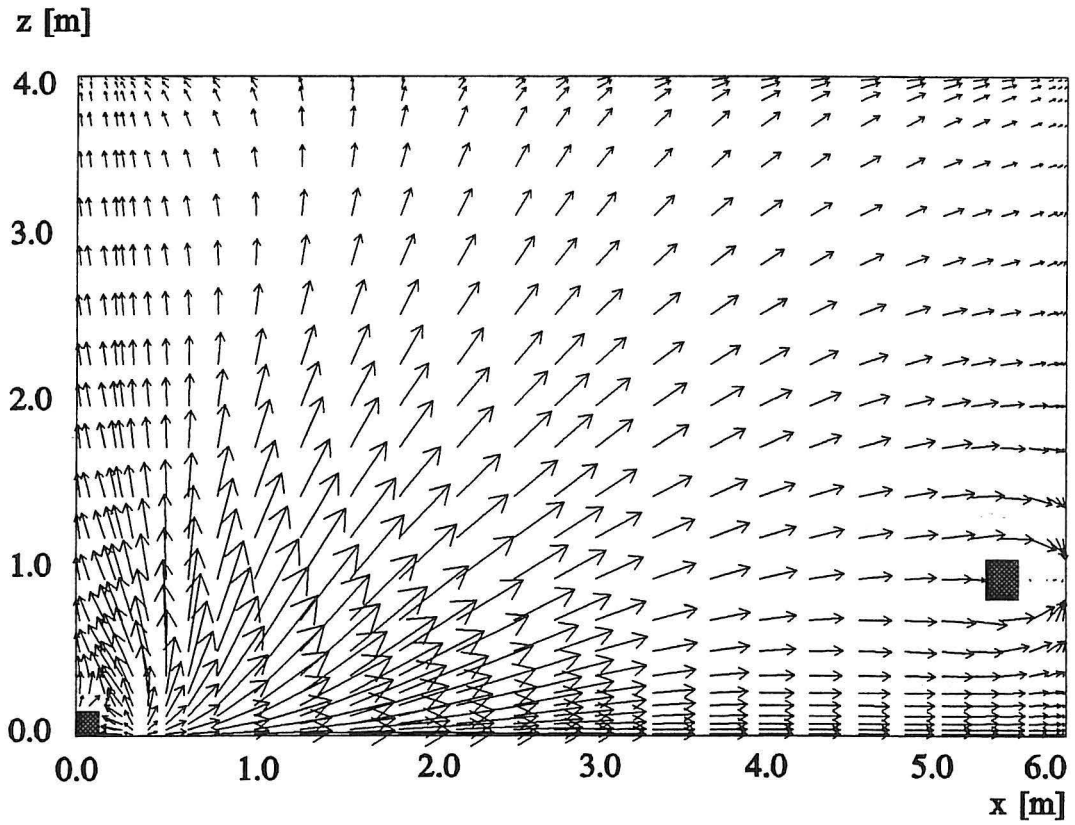

$Ar_r = 720, z=4.0\text{m}$

y [m]

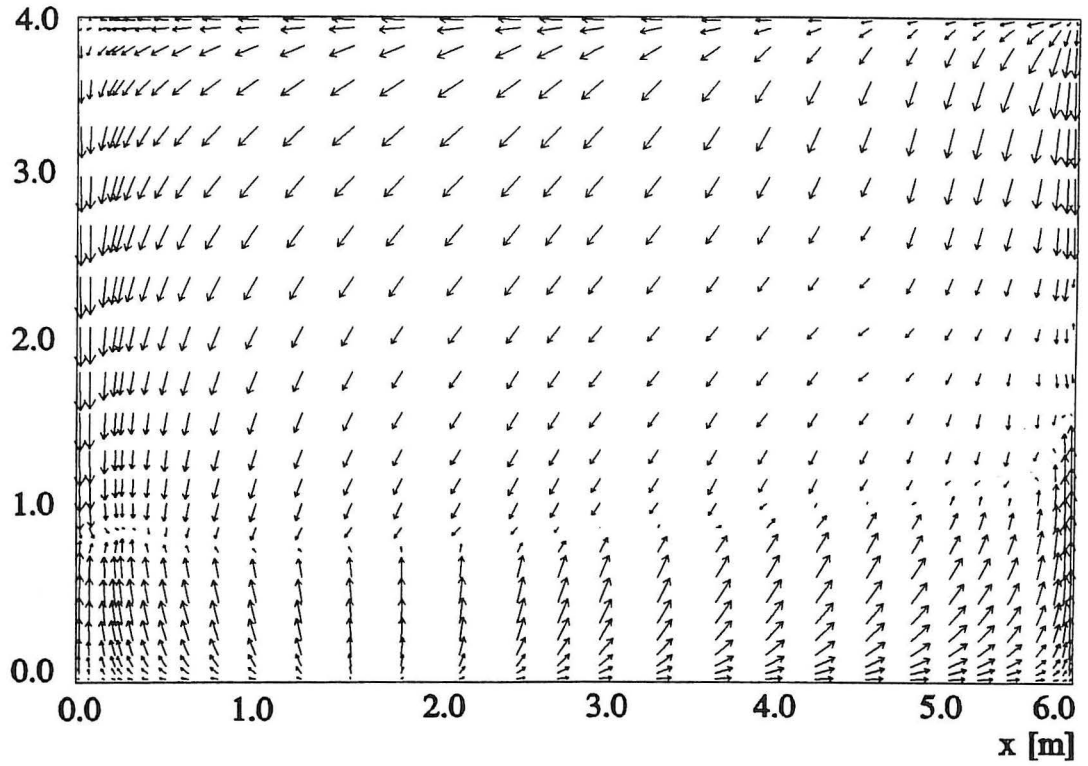

$Ar_r = 720, x=6.0\text{m}$

y [m]

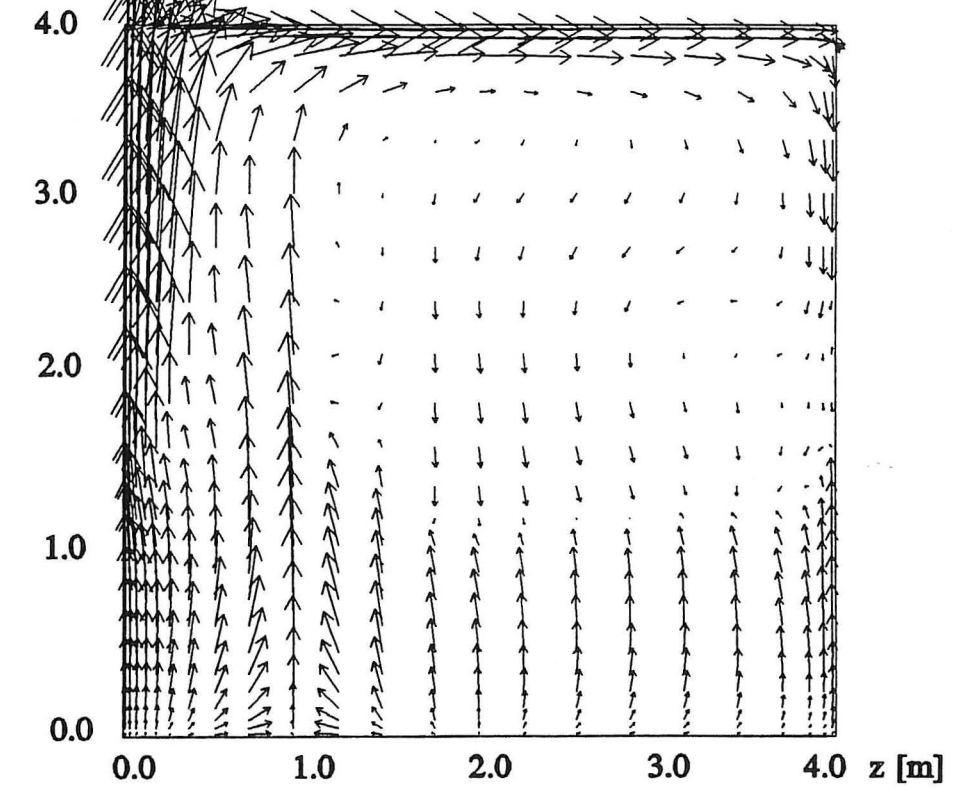

$Ar_r = 94$, $z=0.0m$

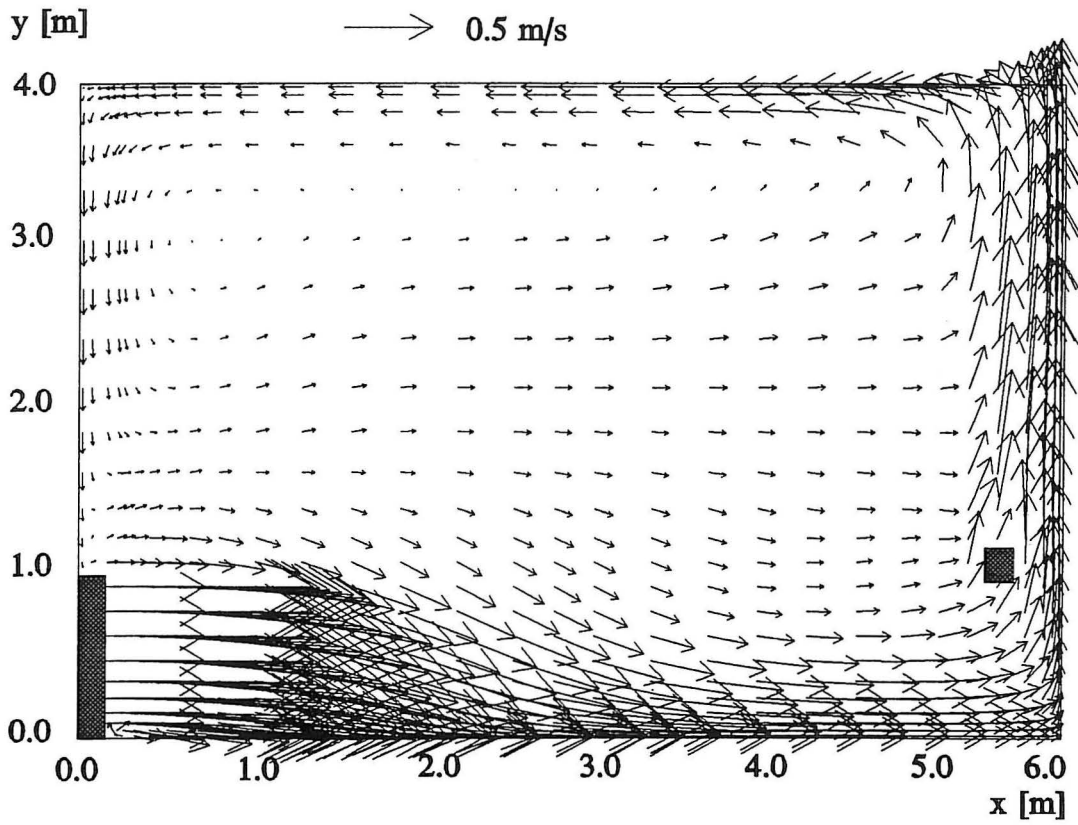

$Ar_r = 94$, $y=0.03m$

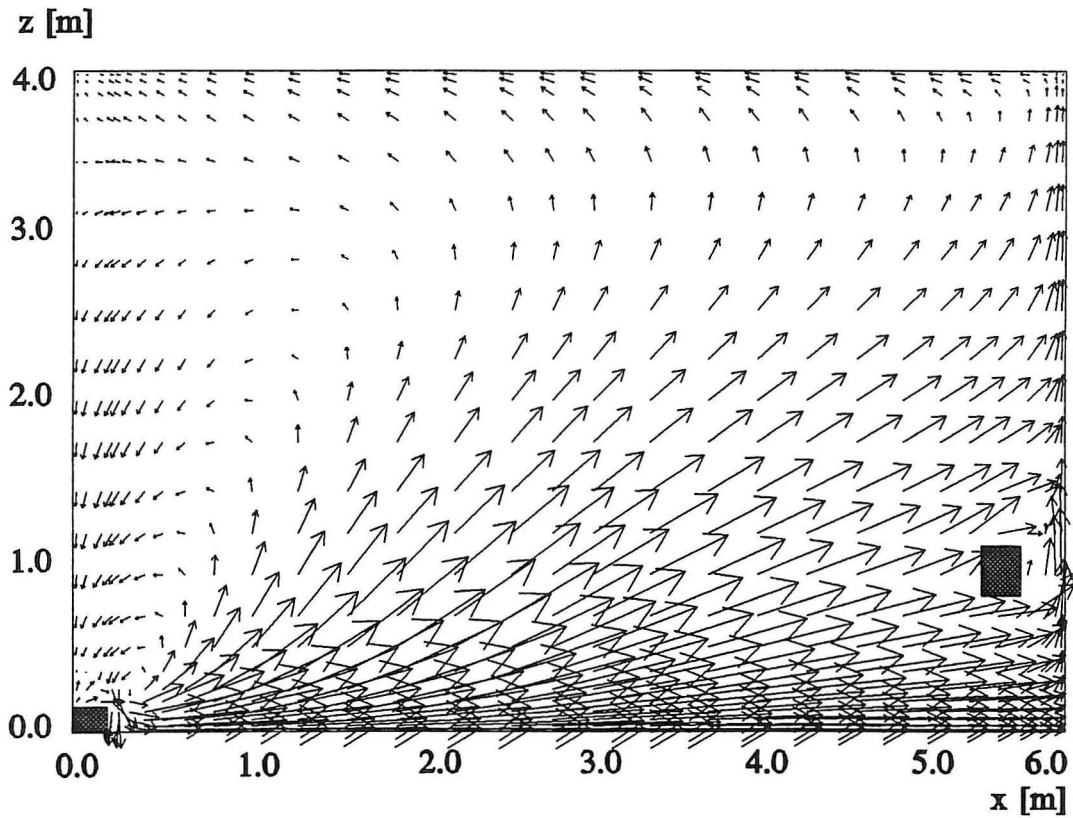

$Ar_r = 94, z = 4.0\text{m}$

y [m]

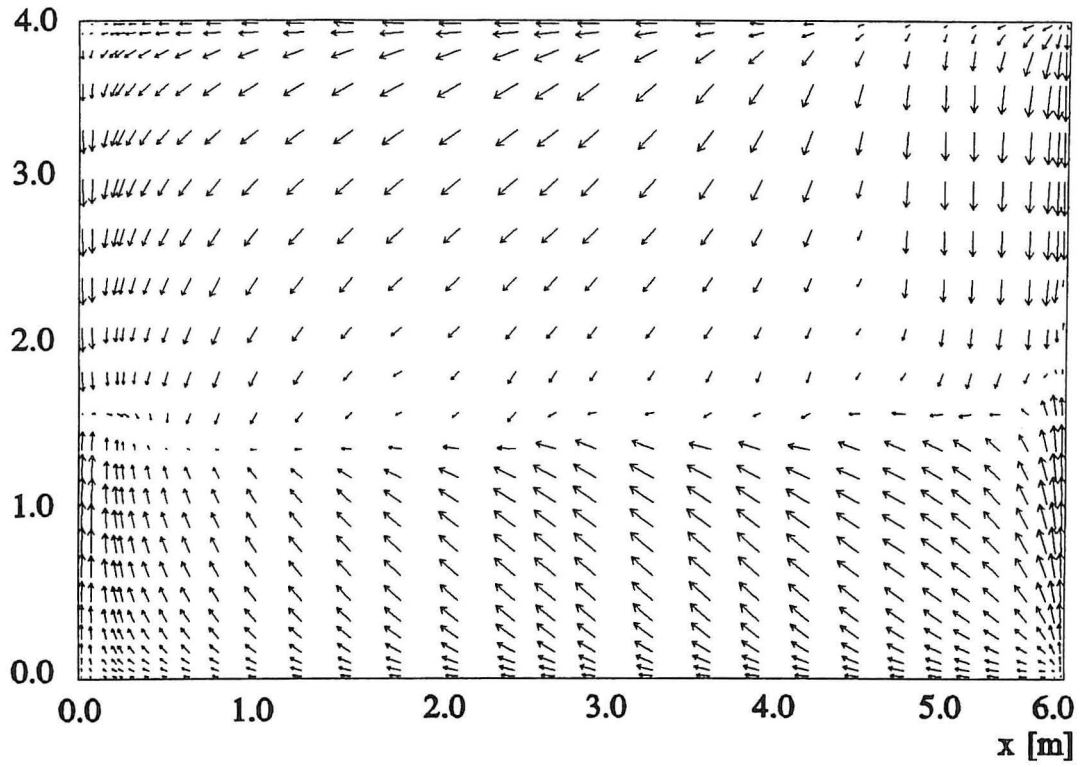

$Ar_r = 94, x = 6.0\text{m}$

y [m]

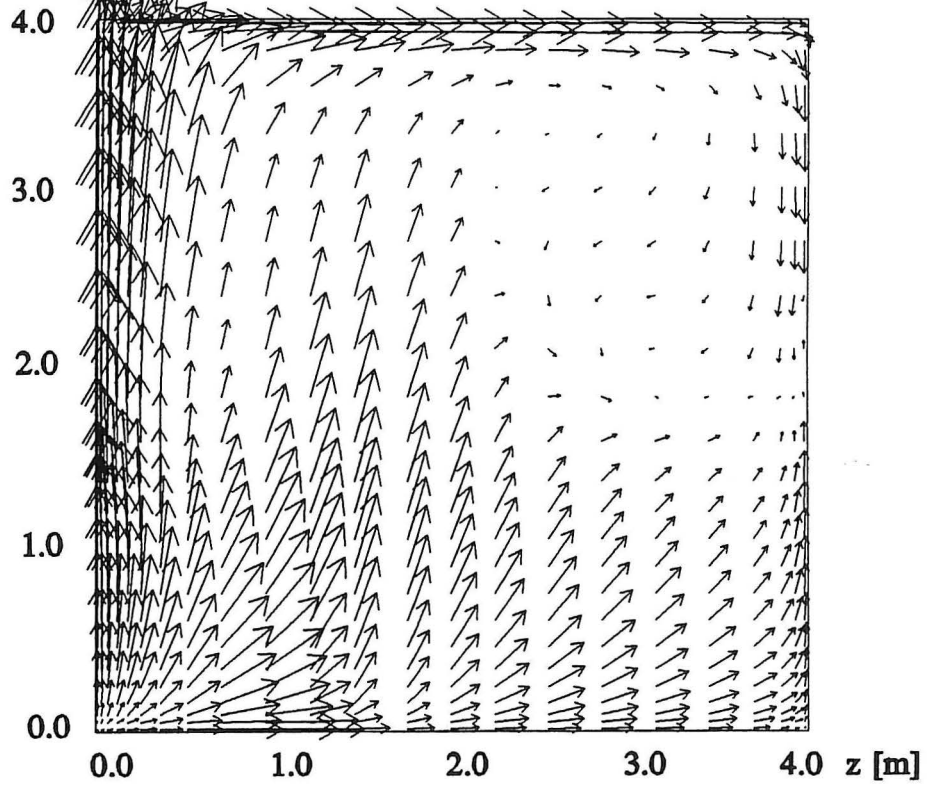

Distance to virtual origin, x_0

$Ar_r=5385$

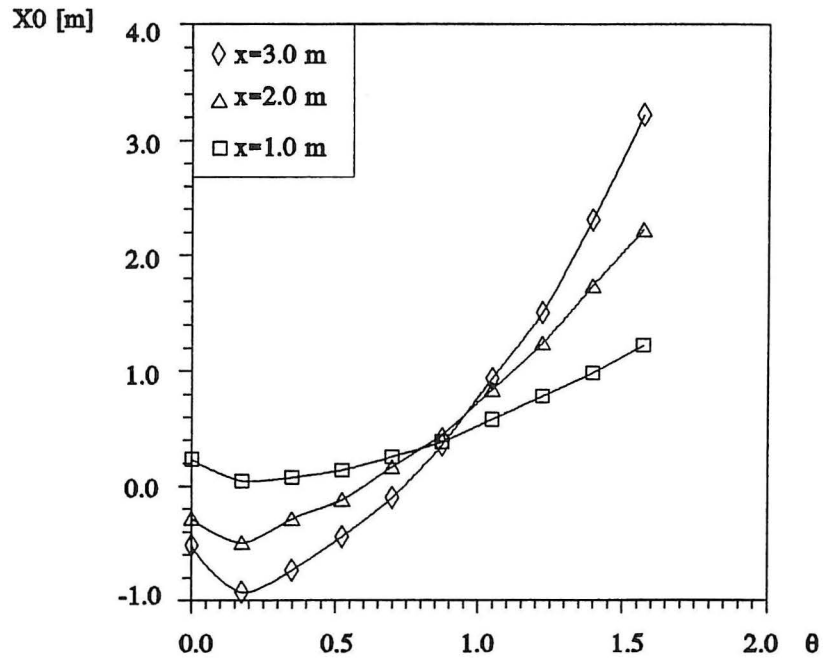

$Ar_r=720$

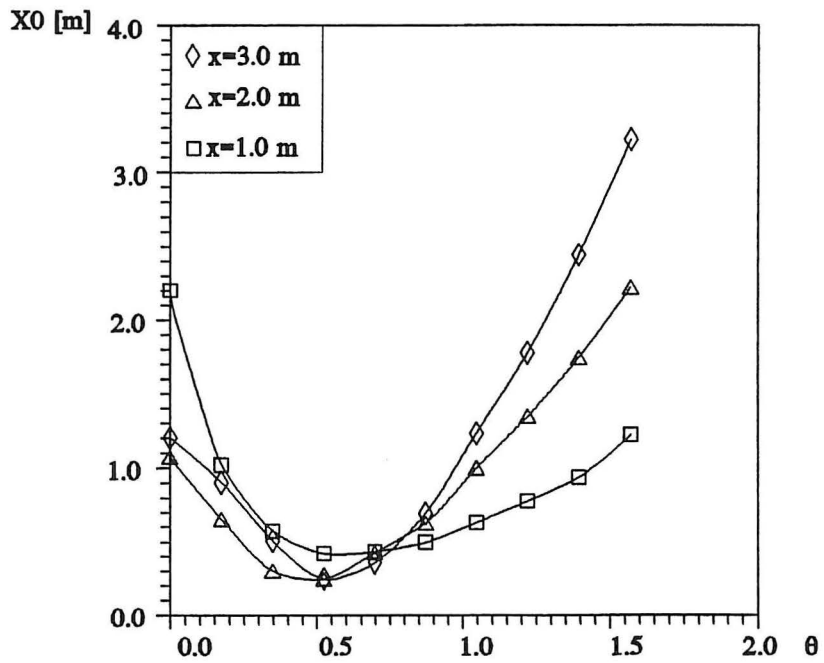

$Ar_r = 94$

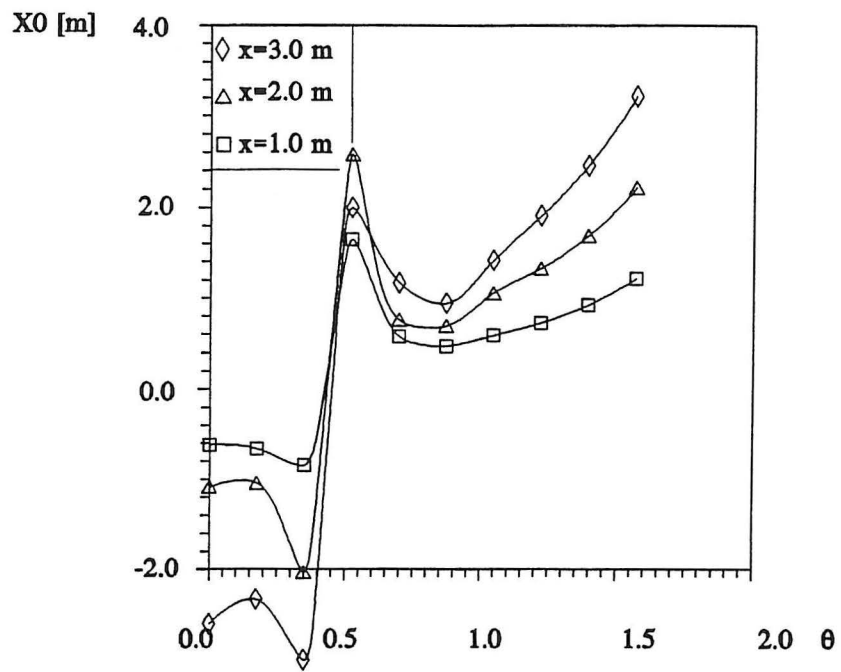

$x=2.0$ m

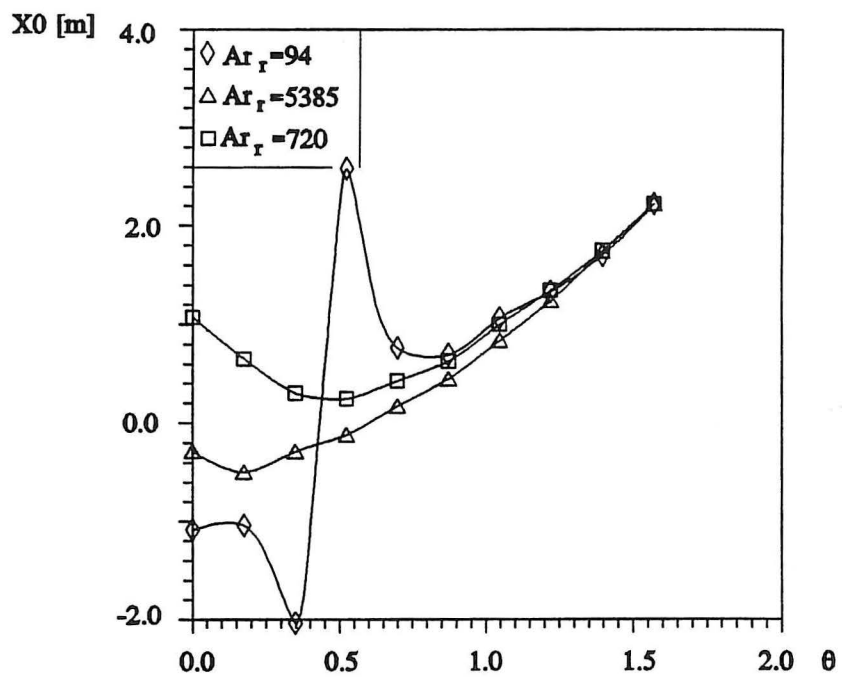

K_θ -values

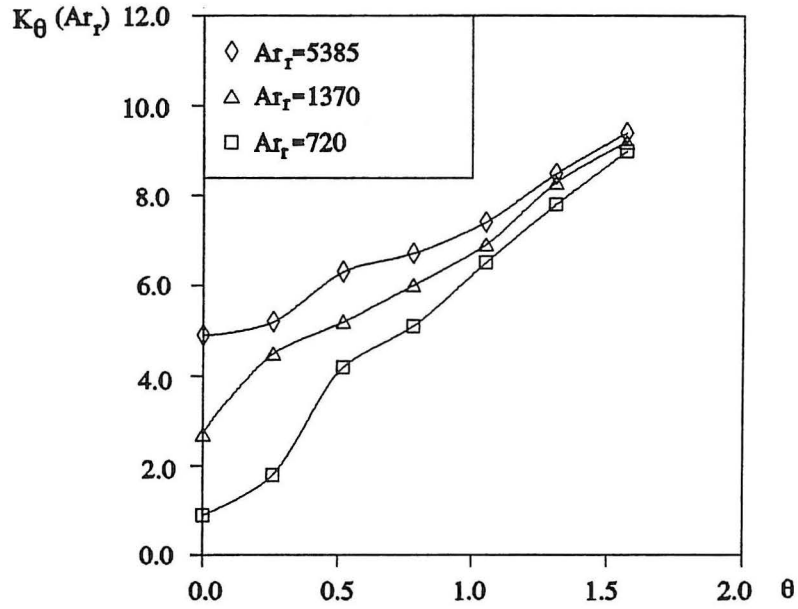

Increment of layer thickness, δ_θ , with distance from the inlet device

$Ar_r=720$

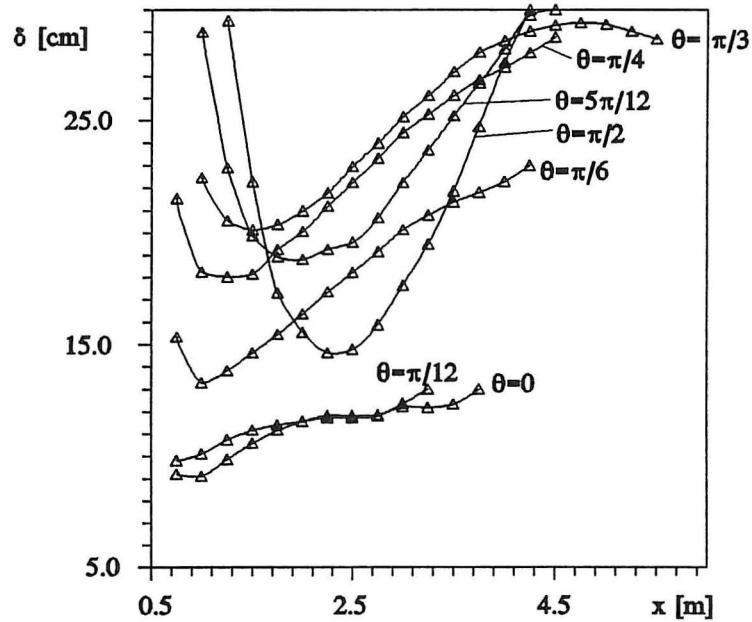

$Ar_r = 1370$

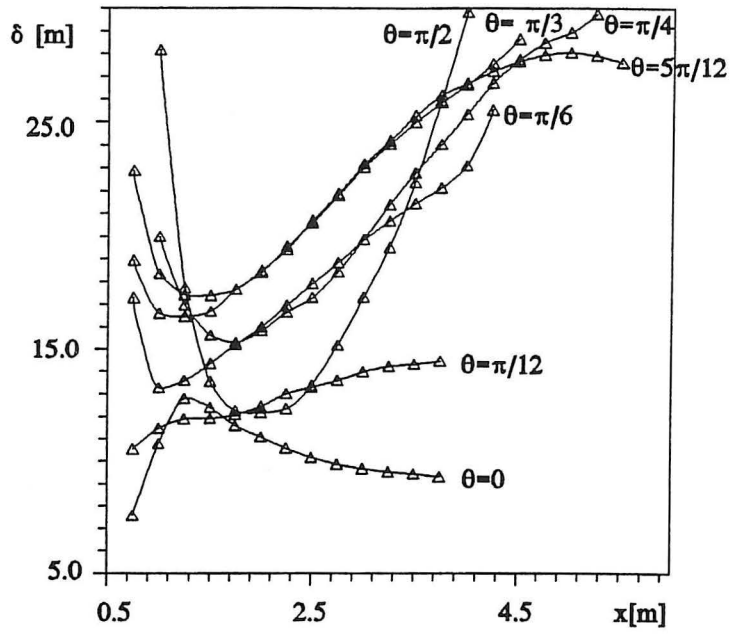

$Ar_r = 5385$

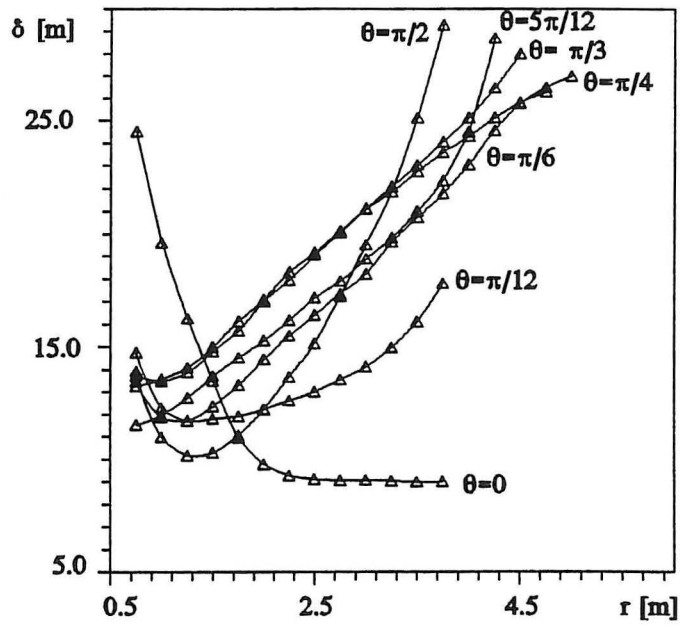

Variation of airflow rates, q_θ , along the angle $\theta = 0 \rightarrow \pi/2$

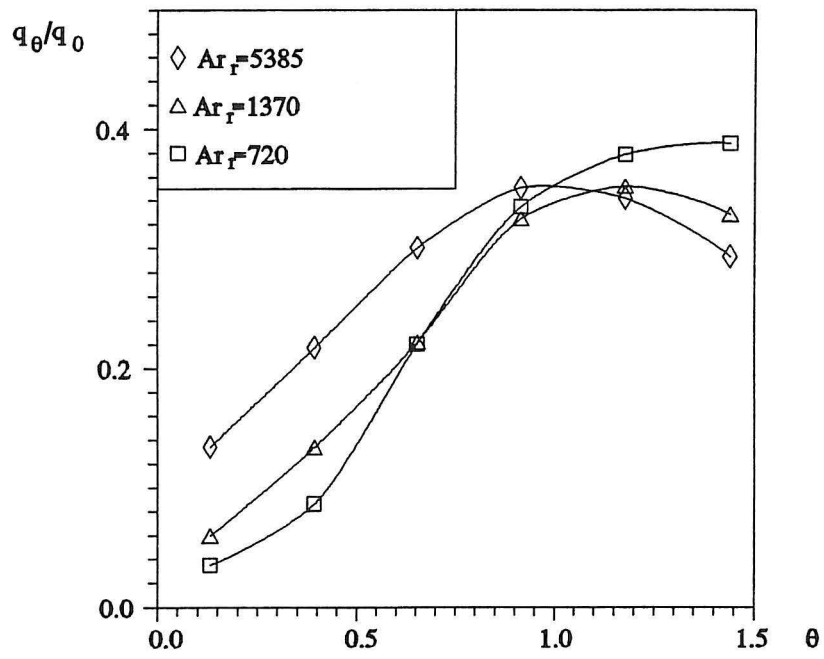

Vector plots, room with an obstacle

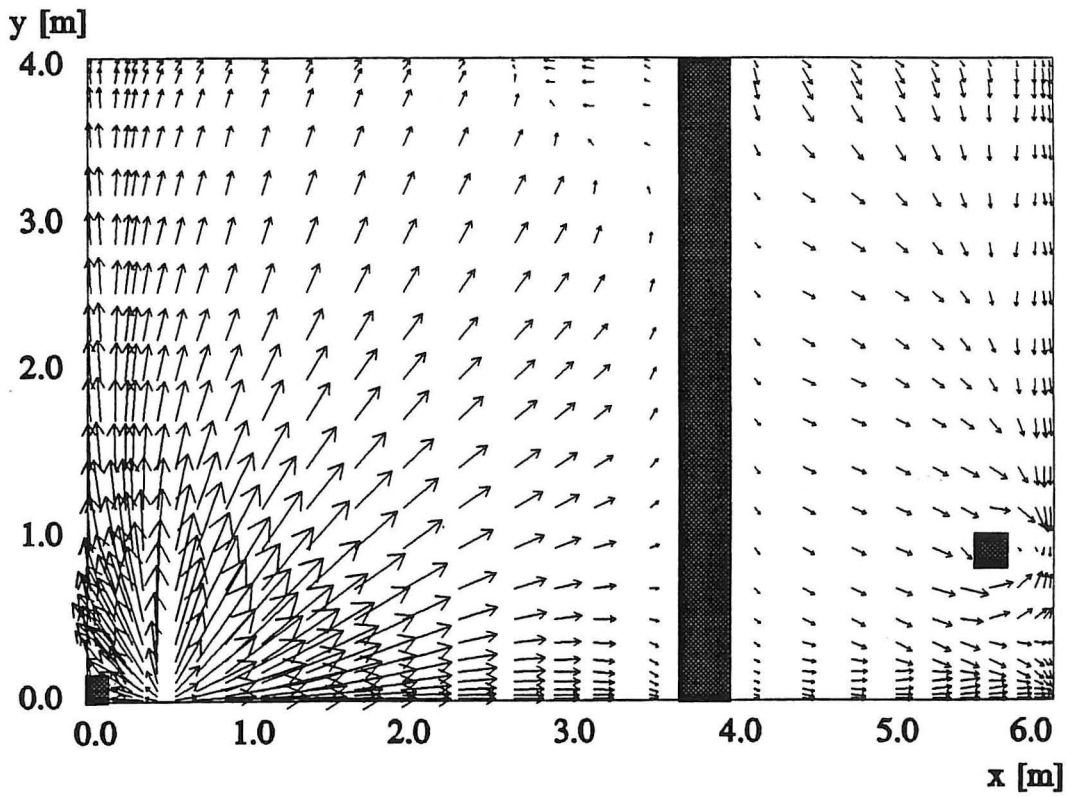
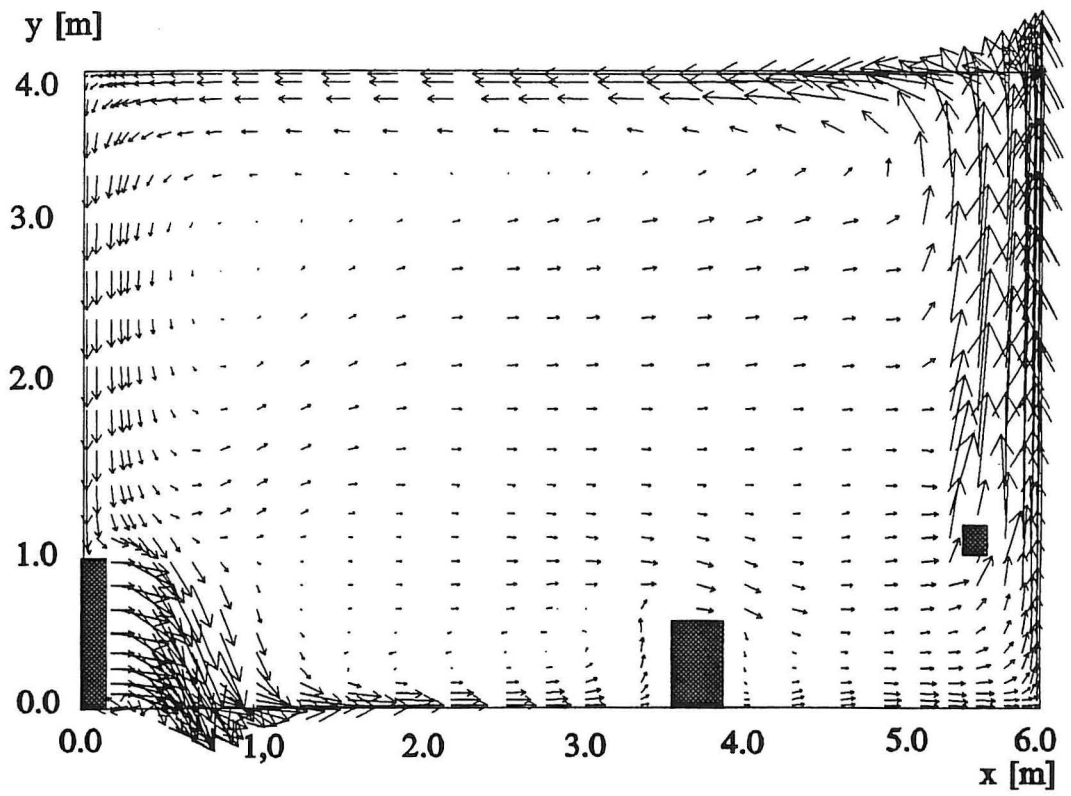

Comparison between maximum velocities, pressure, momentum and layer thickness in the centre line of a room with and without an obstacle

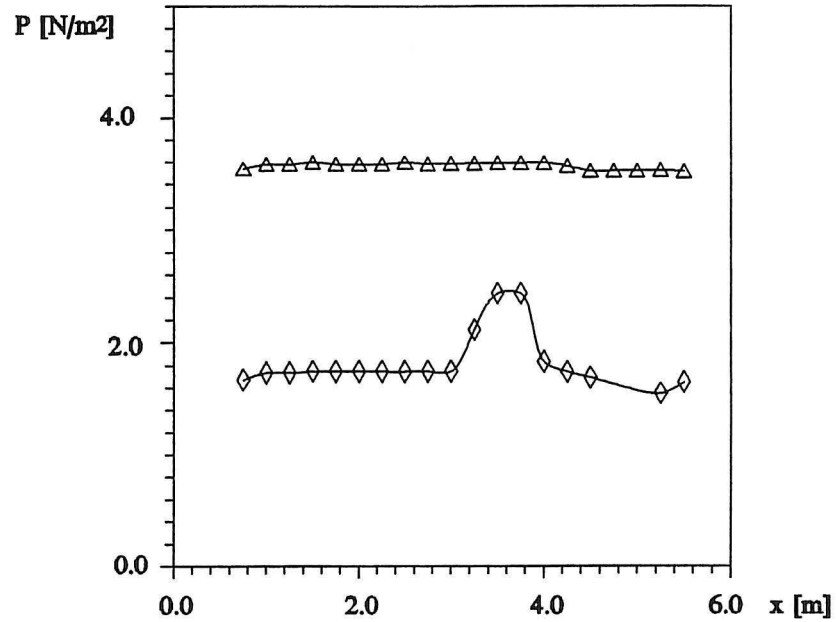
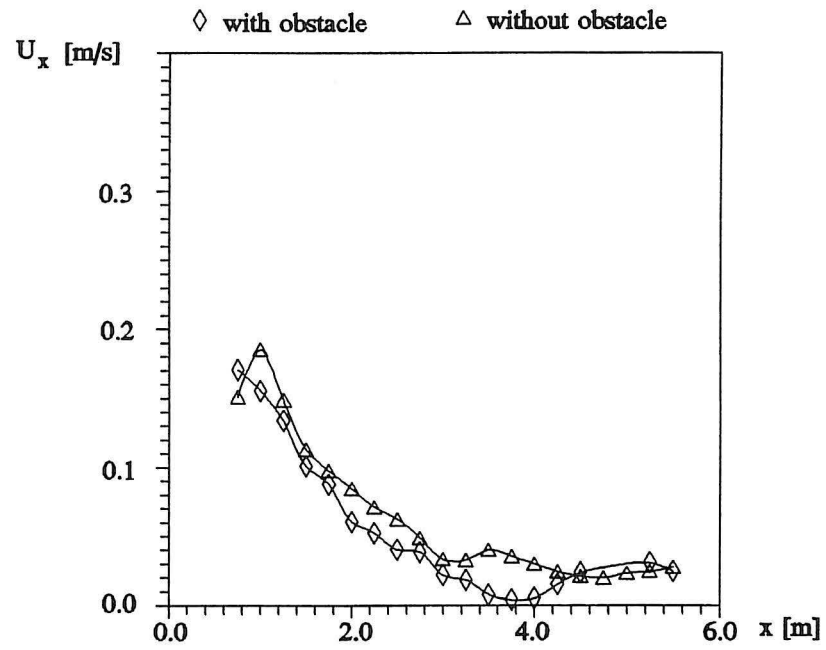

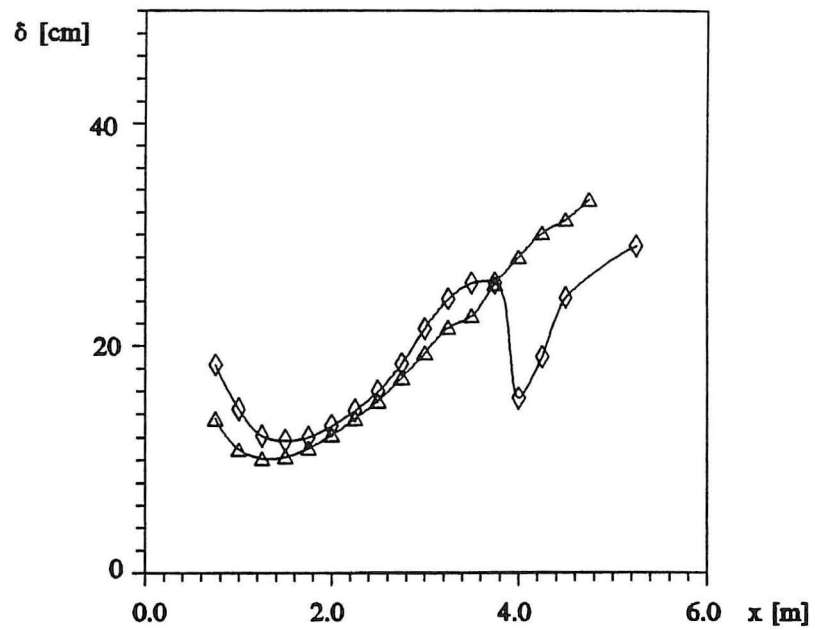
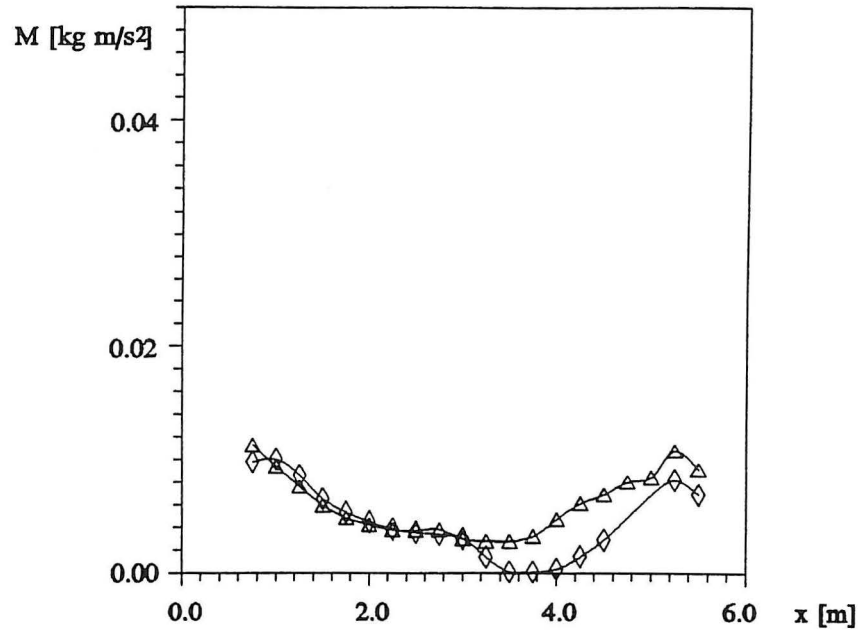

Note : The momentum flow is calculated by integration in an infinitesimal angular section of the flow in the centre line. The upper limit of integration, δ , corresponds to $U_x/2$:

$$M = x d\theta \rho \int_0^{\delta} U(y)^2 dy$$

$Ar_r = 5385$

APPENDIX

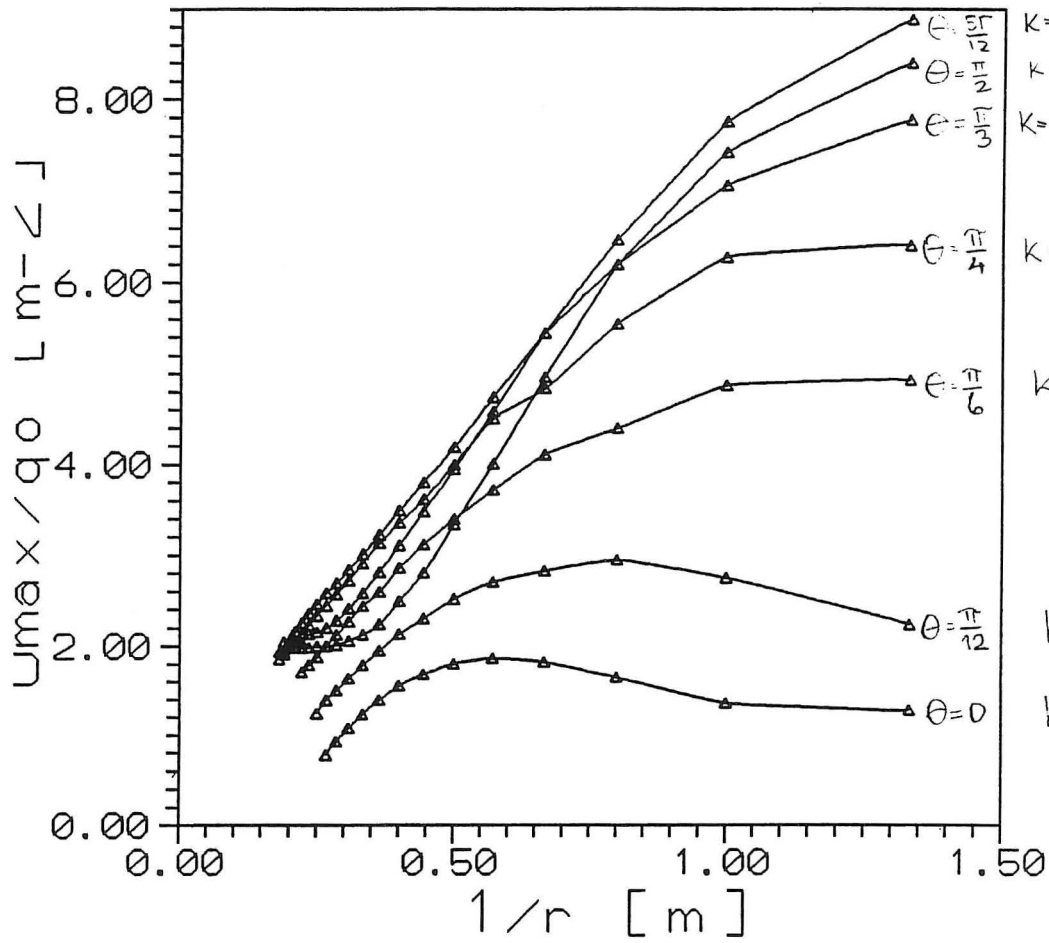

$K = \frac{9.0 - 0}{102 - 0.3} = 8.5$

$K = \frac{9.0 - 0.0}{110 - 0.15} = 8.4$

$K = \frac{9.0 - 0.5}{119 - 0} = 7.4$

$K = \frac{9.0 - 0.6}{125 - 0} = 6.7$

$K = \frac{9.0 - 0.2}{138 - 0} = 6.3$

$K = \frac{9.2 - 0.0}{15 - 0.0} = 5.2$

$K = \frac{9.2 - 0.0}{185 - 0.1} = 4.9$

K

θ	$Ar_r = 720$	$Ar_r = 1370$	$Ar_r = 5385$
0.0	0.9	2.7	4.9
0.26	1.8	4.5	5.2
0.52	4.2	5.2	6.3
0.78	5.1	6.0	6.7
1.05	6.5	6.9	7.4
1.31	7.8	8.3	8.5
1.57	9.0	9.2	9.4

$Ar_r = 1370$

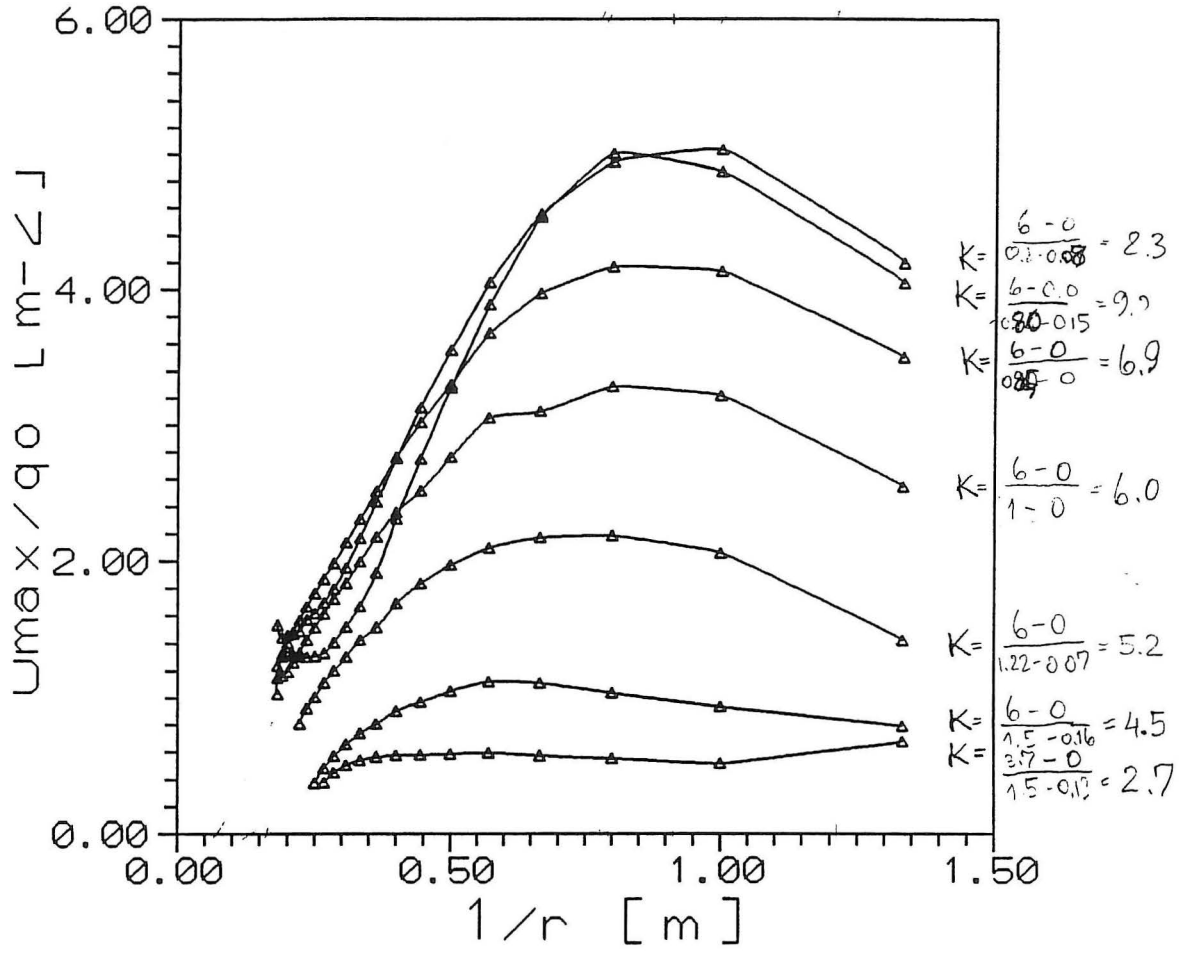

$$Ar_r = 720$$

