



Aalborg Universitet

AALBORG UNIVERSITY
DENMARK

Foundation of the East Bridge

Sørensen, Carsten S.; Steenfelt, J. S.; Mortensen, J. K.; Hansen, Aa.; Gluver, H.

Published in:
East Bridge

Publication date:
1998

Document Version
Publisher's PDF, also known as Version of record

[Link to publication from Aalborg University](#)

Citation for published version (APA):
Sørensen, C. S., Steenfelt, J. S., Mortensen, J. K., Hansen, A., & Gluver, H. (1998). Foundation of the East Bridge. In Gimsing, N. J. (ed.) (Ed.), *East Bridge*

General rights

Copyright and moral rights for the publications made accessible in the public portal are retained by the authors and/or other copyright owners and it is a condition of accessing publications that users recognise and abide by the legal requirements associated with these rights.

- ? Users may download and print one copy of any publication from the public portal for the purpose of private study or research.
- ? You may not further distribute the material or use it for any profit-making activity or commercial gain
- ? You may freely distribute the URL identifying the publication in the public portal ?

Take down policy

If you believe that this document breaches copyright please contact us at vbn@aub.aau.dk providing details, and we will remove access to the work immediately and investigate your claim.

Foundation of the East Bridge

Carsten S. Sørensen
COWI

Jørgen S. Steinfeldt
Danish Geotechnical Institute

Jens Kammer Mortensen
Rambøll

Aage Hansen
A/S Storebæltsforbindelsen

SYNOPSIS: The paper presents an overview of the East Bridge project, the geotechnical investigation strategy employed and the particular challenges experienced by the geotechnical engineers in the course of the project. The lessons learned from the East Bridge are that the interplay between geotechnical engineers and their counterparts in structures and geology are prerequisites for cost effective and safe solutions as well as for advancements in state-of-the-art. This paper deals with the foundation of the East Bridge where the interplay of various disciplines, test types and numerical approaches played a major part in achieving a safe foundation design. Lessons learned, during construction of the other parts of the Link, have tacitly been implemented.

1. INVESTIGATION STRATEGY

1.1 Previous knowledge and its implementation

Preliminary investigations for a fixed link across Storebælt were carried out in 1962-63. They were followed by a more detailed campaign in 1977-78, where the plan for a fixed link was once more aborted.

In 1983 two deep borings were carried out into the marl in connection with a feasibility study for a tunnel solution. The most recent campaign started in 1986 corresponding to the inception of the investigations for the current project.

Throughout these investigations the alignment corridor for the bridge between the islands of Sprogø and Sjælland was rather well defined.

The investigations comprised seismic profiling, borings, laboratory testing as well as geological studies for the top 100 metres of the deposits. In 1987 the results in the form of soil boundaries and geological layer characteristics, were implemented in a newly established 3D computer data base, *the Geomodel*. The model was established by Storebæltsforbindelsen for use and access by the client (management), the consultants (updating and design) and the contractors (construction).

Hence, the ground conditions for the East Bridge were fairly well known in advance, allowing alignment as well as bridge type to be selected. The foundation solutions could be proven by detailed investigations performed simultaneously with the detailed design.

1.2 Overview of geology

A comprehensive geological model, based on the investigations up to 1979 and relevant for the East Bridge, was presented by Larsen et al (1982).

The Eastern Channel of Storebælt (the Great Belt) was flooded during the Flandrian transgression, starting some 8,000 years ago, and minor marine sediments were deposited.

Some 10,000 years ago the Storebælt area was dry land and the deep Eastern Channel was a north flowing river, eroded into the indigenous deposits and with early melt water deposits. Depressions were filled with peat and mud.

The predominant feature for the foundation are two glacial till units originating from two main glaciation periods, the Weichsel glaciation and the Saale glaciation. Only in the deep channel are these tills missing. The thickness of the glacial sequence is some 20 metres, however, increasing to more than 70 metres when approaching Sjælland.

During the Weichsel glaciation the upper till unit was deposited close to the ice border line, presumably some 13,000 years ago. The lower till unit originates from the Saale glaciation and is believed to be some 120,000 - 140,000 years old.

The Prequaternary deposits consist of Selandian marl, known as the Kertemindemergel, resting on Danien limestone and at greater depth, the Maastrichtian chalk. The thickness of the Kertemindemergel is some 40 metres.

The prevailing geological setting for the Storebælt Link project, in the light of all investigations up to 1995, is summarised by Foged et al (1995). The corresponding schematic geological section in the East Bridge alignment is shown in Figure 1.

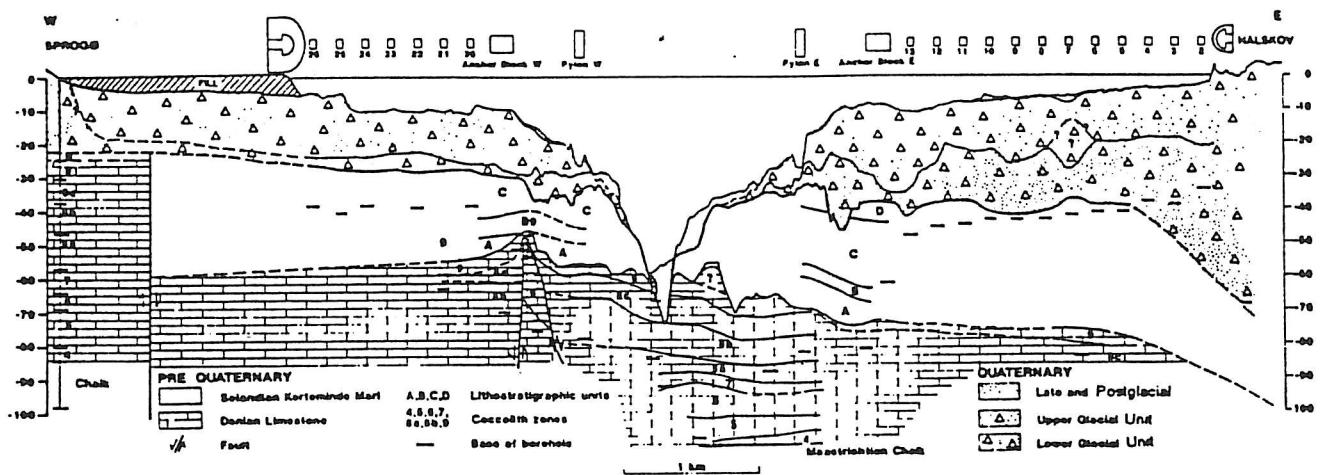

Fig. 1. Schematic geological section in East Bridge alignment (after Foged et al, 1995)

2. EAST BRIDGE INVESTIGATIONS

Prior to the detailed investigations for the East Bridge important experiences were gained from the West Bridge detailed investigations and early construction activities, namely:

- in 1989 the Geomodel was upgraded to an intelligent data base with storage facilities for geotechnical parameters,
- the CPT technique had proven very useful for detailed mapping of ground conditions at each pier location as a supplement to regular geotechnical borings,

- the importance of field testing such as large plate load testing had been realised and initiated at the island of Sprogø,
- the tills had proven to exhibit much more varying strength properties than ever anticipated,
- direct foundation on compacted gravel pads was feasible,
- onshore prefabrication of elements could minimise marine construction.

For the detailed investigations in 1990 - 92 the following program was established.

2.1 General

The aim of the investigation was to establish a proper 3D geological and geotechnical knowledge for the subsoils down to the depth affected by each structural element.

A total of 100 geotechnical borings should be taken to some 30 - 40 m below the seabed with a typical spacing of 20 - 40 m at structural element positions. These borings should include sampling, vane testing, and SPT. In selected bore holes, mainly at the pylon and anchor blocks, pressuremeter tests should be carried out. Some 400 CPTs should be carried out to 20 m below the seabed with a typical spacing of 10 - 20 m at structural element positions.

Laboratory testing should include classification testing as well as strength and deformation testing. Small scale testing should be supplemented by large scale triaxial and shear testing of soils and crushed rock gravel.

The sliding issues for anchor blocks and for piers during ship's impact should be elucidated by performing large scale sliding plate load tests onshore at Sjælland on intact as well as on remoulded clay tills.

2.2 CPT tests

Particular attention was paid to the analysis and numerical filtering of CPT tests in the clay till, drawing on the extensive experience gained from the West Bridge testing.

The clay till is a mixture of clay, silt, sand and gravel whose general behaviour is governed by the clay. The effects from sand and gravel traces on the CPT tests were considered a *noise* to be filtered out.

For each CPT test the spikes pertaining to sand and gravel were removed with a moving average filter as described by Mortensen et al (1991). Then a plot was produced displaying all the resulting CPT q_C profiles. If they demonstrated the same general trend a set of three plots was produced as described by Feld and Gravgaard (1994), showing (see Figure 2):

- collated profiles of average q_C and average of the minima q_C profiles
- a plot of the in situ vane shear tests, and
- a plot of the water contents, w , and activity, A , from the laboratory tests.

The average of minima plot was intended to represent a *conservatively estimated mean value*, as required by DS 415 (1984), the Danish Code of Practice. If a varying picture of soil appeared, more than one profile was elaborated to provide fully representative soil profiles for the pier. An even more prudent estimate was not considered necessary since any failure would have to pass through the weaker as well as the stronger parts of the soil.

From these tests and the geological descriptions of samples from the geotechnical borings a Characteristic Design Soil Profile could be produced. This profile was used as the basis for the foundation design.

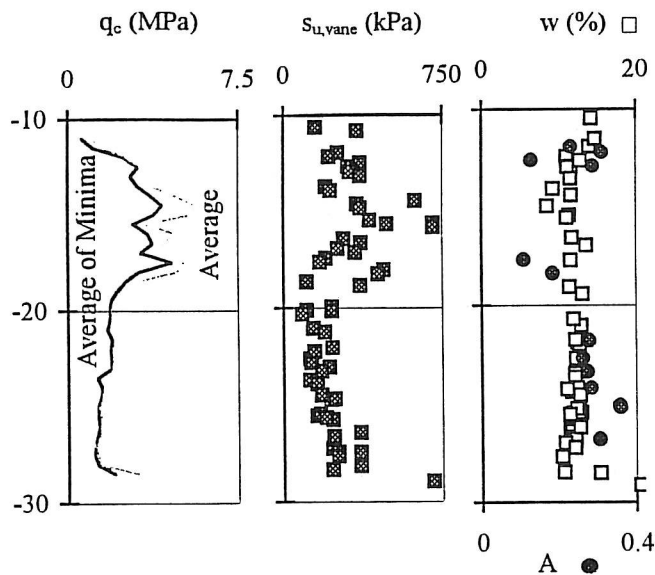

Fig. 2. Example of background plots for Design Soil Profile from an approach pier (vertical axis is level in metres)

2.3 Laboratory test scheme, intact clay till

A general pattern of behaviour in terms of relations between strength, preconsolidation stress and in situ vertical stress appeared when SHANSEP was applied to the laboratory test data (cf Steenfelt and Foged, 1992).

Advanced, high quality laboratory tests were performed on a select array of intact samples covering the widest possible spectrum of in situ strengths and stresses rather than on specimens from every pier. The undrained shear strength of the clay till was determined by triaxial compression ($c_{u,C}$) and extension ($c_{u,E}$) tests as well as by volume constant direct shear tests ($c_{u,DS}$).

The triaxial tests were carried out on 70 mm diameter specimens with a height/diameter ratio of 1 and smooth pressure heads in order to ensure homogeneous strain conditions. In order to produce reliable results the in situ stress history was reproduced by anisotropic consolidation to the preconsolidation stress followed by unloading to the in situ stress prior to the load test to failure.

The direct shear tests were carried out in an automated, very rigid purpose-built shear box (DAS). The specimens were cylindrical, 70 mm diameter, with a height of 30 mm. The tests were carried out as volume constant tests in order to simulate undrained conditions.

The suite of laboratory tests was compared to the field values of undrained shear strength. They consisted of $s_{u,vane}$, from field vane tests in the boring and $s_{u,CPT} = q_c/N_k$ inferred from CPT tests carried out close to the relevant bore hole (s_u is here used for the in situ determined undrained shear strength as opposed to c_u in the laboratory). The relationship between s_u and q_c was based on the correlation of all vane and CPT tests carried out in the clay till in the Eastern Channel area.

The following strength model was found to apply for the intact clay till:

$$\begin{aligned}
 c_{u,C} &= 0.42\sigma'_v(\sigma'_{pc} / \sigma'_v)^{0.85} \\
 c_{u,DS} &= 0.86c_{u,C} \\
 c_{u,E} &= 0.71c_{u,C} \\
 s_{u,vane} &= 0.88c_{u,C} \\
 s_{u,CPT} &= q_c / 10
 \end{aligned}
 \tag{1}$$

3. PARTICULAR CHALLENGES

3.1 Foundation principles

The main geotechnical challenge was the mere size of the project which was beyond normal experience and code of practice.

This fact led to very thorough investigations as well as a very careful independent assessments of the safety philosophy considering the serious consequences for the Danish Nation of any interruption of the link across the Storebælt.

The quality of the design was optimised by applying completely independent design models for all key issues.

The main issues to be considered were the sliding stability of the anchor blocks and ship's impact on piers close to the heavily trafficked navigation channel.

Throughout the long pre-history of this bridge it was always expected that the principle should be that of a direct shallow foundation.

Based on the West Bridge experiences it was decided that all footings should rest on compacted gravel pads of crushed rock. Considering the extreme dimensions, all caissons should be manufactured with a skirt system, designed for penetration into the gravel pad, and thus establishing an ambient space for grouting.

3.2 Anchor blocks

Each anchor block has a rectangular base with the length of 121.5 m and the width of 54.5 m (cf Figure 3). This base is divided into 3 parts, a front pad of 41.7 m, a middle part of 39.1 m, and a rear pad of 40.7 m. Only the front and the rear pads are in contact with the supporting soils.

Both anchor blocks are founded on very stiff to hard preconsolidated clay till. The undrained shear strengths range from 150 to 300 kPa.

As a result of excavation the top part of the clay till was expected to be disturbed and to have a reduced sliding resistance. This problem was compensated for by introducing a wedge shaped fill of compacted crushed stone below each of the two pads.

3.2.1 Anchor block loads

The loading situation on Figure 3a leads to a resultant force as shown in Figure 3b. Assuming a uniform vertical load distribution for each of the two pads, the two vertical reaction forces are statically determined.

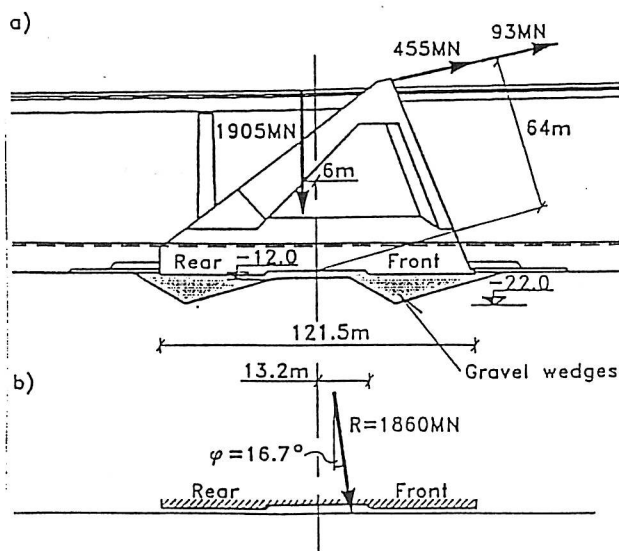

Fig. 3. (a) Section of anchor block; (b) Load resultant acting at foundation level

The horizontal shear load can be assumed distributed in such a way that the two foundation pads have the same safety against bearing capacity failure. This assumption is not necessary with a Finite Element Analysis where the total structure is analysed and where the horizontal shear load is distributed automatically. This, of course, implies that the concrete superstructure has the rigidity and the strength needed to distribute the shear loading.

3.2.2 Bearing capacity analysis

The bearing capacity analysis was performed both as a traditional deterministic and as an advanced probabilistic ultimate limit state analysis. The partial factors used for the deterministic analysis are summarised in Table 1.

Three principally different types of failure modes are possible for each foundation pad depending on load inclination, see Figure 4.

The critical mode for a given case will depend upon geometry, soil strength, and the inclination of the resultant force. The failure mode that involves sliding along the disturbed clay till surface has been discussed earlier in some detail by Mortensen (1983).

A correct solution for the bearing capacity has to be both statically and kinematically admissible.

Table 1. Partial factors applied in deterministic analysis

Quantity	Partial factor	Value
Permanent action	γ_G	1.0
Variable action	γ_Q	1.3
Tangent of internal angle of friction	γ_j	1.3
Undrained shear strength	γ_c	2.0

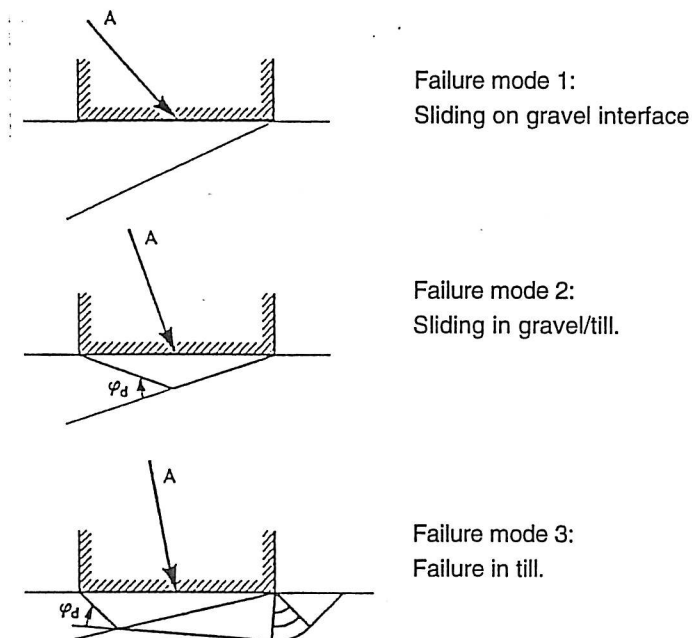

Fig. 4. Foundation Pad Failure Modes

But it is difficult to find solutions which fulfil both conditions. Therefore, it was decided to use three different and independent calculation methods to determine the bearing capacity of the anchor blocks. The selected methods, all in 2D, included:

- Upper Bound Theory (deterministic and probabilistic)
- Limit Equilibrium Analysis (BEAST)
- Finite Element Analysis (ABAQUS)

Prior to calculation of the bearing capacity of the anchor blocks the three calculation methods were tested through five bench mark cases. From the results it was concluded, Sørensen et al (1993), that all three methods could be considered as relevant and usable tools for the design procedure.

One of the tests was called *The Anchor Block Case* with a geometry and a soil strength nearly identical to those of the real anchor block. The calculated resulting bearing capacities were found to range from 32.3 MN/m to 33.8 MN/m (corresponding to the 2D simplification of strip footings). The rupture figures for the upper bound and ABAQUS analyses are shown in Figures 5 and 6.

In addition to these 2D analyses, supplementary 3D analyses were performed for verification of the adequacy of the 2D analyses.

The probabilistic analysis indicated a coefficient of reliability of $\beta = 4.9$. This corresponds to the high safety class in the Danish codes.

3.2.3 Soil Strength

Substantial efforts were launched to determine the strength of the soils involved. These efforts have led to a degree of confidence corresponding to the complexity of this structure in agreement with DS 415, High Foundation Class.

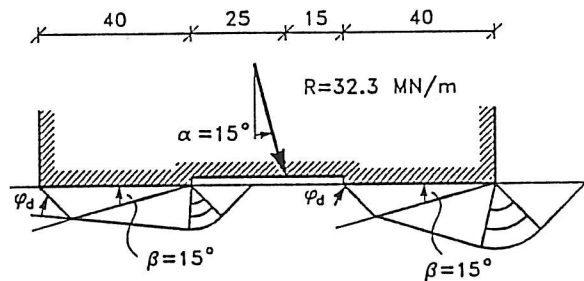

Fig. 5. Rupture figure, Upper Bound analysis

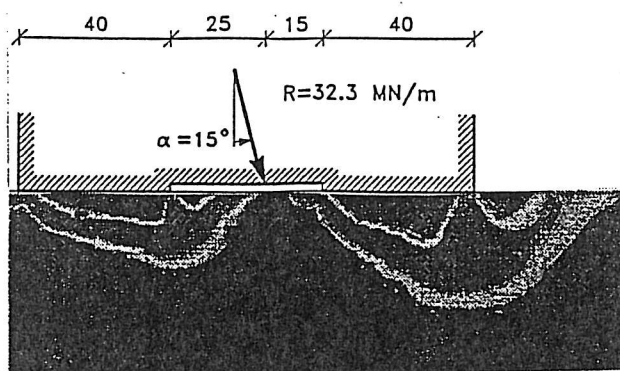

Fig. 6. Rupture figure, ABAQUS analysis

Crushed stone in gravel wedges

The crushed stone is a Hyperite quarried from Kragerø, Norway. The grains are equant to disc shaped with a high grain density of $\rho_s = 3.12 \text{ Mg/m}^3$ and with a high compression strength of $\sigma_c = 150 - 200 \text{ MPa}$ with a mean value of 170 MPa. The grain size curves for the compacted material showed a mean grain size of $d_{50} \approx 15 \text{ mm}$ and a uniformity coefficient of $C_U \approx 10$.

Triaxial tests, carried out in a large, purpose-built, triaxial set-up with cylindrical specimens of 500 x 500 mm size, indicated very high values of the triaxial secant angle of friction, $\varphi > 50^\circ$. In all the tests the material dilated at failure but the rate of dilatancy was lower than expected. For further information see Steenfelt and Foged (1994).

The upper bound bearing capacity calculation tacitly implies that the angle of dilatancy ψ equals the internal angle of friction φ in contradiction of test results. A correction, where the stress condition on Mohr's circle for stresses is dictated by ψ rather than φ , was used for this calculation. This corresponds to a reduced angle of friction φ_δ

$$\tan \varphi_\delta = \frac{\sin \varphi \cos \psi}{1 - \sin \varphi \sin \psi} \quad (2)$$

The question of shear transfer through the crushed stone wedge to the clay till interface was further addressed by conceptual, small scale laboratory model tests (Steenfelt et al, 1994).

Analyses of the test results, in particular the displacement patterns, and comparisons with ABAQUS finite element simulations confirmed the relevance of Eq. (2) for this problem.

Trial compaction

It was considered difficult to devise proper methods for in situ compaction control of the crushed stone beds under the construction elements. Instead a method prescription system was adopted for the placing and compaction of the crushed stone. In order to verify this system a trial pit enclosed by sheet piling was established onshore for under water, full scale compaction trials (see Figure 7).

Material excavated from the trial pit, after compaction and lowering of the water table, was used for the large scale laboratory tests described by Steenfelt and Foged (1994).

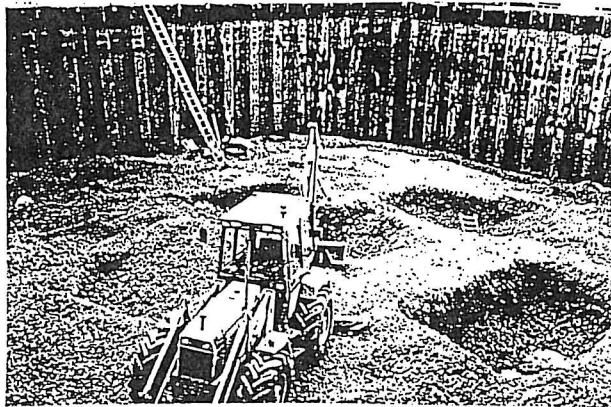

Fig. 7. Excavation of crushed stone in trial pit

Clay till (emphasis on disturbed state)

The bearing capacity of failure mode 2 (cf Figure 4) is given by the geometry of the rupture figure and the strength of the transition zone between the gravel and the intact clay till. The excavation in the clay till ahead of placing and compacting the crushed stone in the gravel wedges will inevitably disturb/remould the topmost part of the clay till.

Determination of the strength of this zone was one of the key parameters for the design of the anchor blocks. A comprehensive test program was evaluated necessary before a final conclusion could be drawn. The test program contained tests in the field as well as tests in the laboratory.

The field tests comprised 28 sliding tests with 1 x 2 m² concrete blocks placed on clay till with different degrees of disturbance and loaded with different displacement rates. For further information see Hansen et al. (1991) and DGI (1991).

The laboratory tests comprised more than 70 interface tests in the purpose-built Large Sliding Box. The tests were carried out on 400 mm cylindrical and 100 mm high reconstituted clay till specimens. For comparison, 20 conventional Direct Shear Box tests on 100 by 100 mm² and 30 mm high reconstituted clay till specimens were carried out too.

The effects from consolidation, ageing, pre-shearing, and displacement rates were tested. The test conditions and the results are evaluated and presented in detail by Steenfelt (1993).

3.2.4 Settlement

The use of advanced calculation methods was the only possible means of calculating the direction and size of the settlement of the anchor block. By using the finite element program ABAQUS it was possible to include the effects of

- the special geometry of the anchor blocks,
- the geometry of the gravel wedges,
- the limited thickness of the clay till, and
- the loading sequence of the anchor block.

Oedometer and triaxial test results formed the basis for the determination of the soil deformation parameters.

3.3 Pylons

Each 254 m high pylon has a base with a length of 78 m and a width of 35 m.

The dimensions of the base were primarily dictated by the requirements for structural integrity in the base and in the lower part of the pylon legs and secondarily by bearing capacity and settlement criteria.

A special task involved the assessment of the risk for liquefaction in the soil below the base due to wind loading during construction of the pylons.

Analyses, based on traditional liquefaction models as well as a recently published new liquefaction model by Ibsen (1994), showed that this risk is negligible.

3.3.1 Skirt penetration

The very high friction angles for the crushed stone bed material gave rise to some concern in connection with the placing of the precast lower part of the pylons. The question was whether sufficient skirt penetration would be achieved.

However, by placing a screeded, looser layer at the top of the stone bed the predicted load-penetration response was achieved with full skirt penetration and desired base contact prior to grouting of the concrete-stone interface.

3.4 Approach Piers

The base of the approach piers is typically 23 m long and 19 m wide.

Bearing capacity analyses in the limit states, ULS and ALS were treated in a top-down manner. First a simple analysis, with the weakest soil parameters from the Design Soil Profile (cf Figure 2), was carried out for all piers with their individual geometries and loads. Then for those particular piers with bearing capacity problems a more refined analysis was applied taking the spatial variation of the soil strength into consideration.

3.4.1 ULS - Ultimate Limit State

All piers in all load cases and projections were analysed in one run according to DS 415.

Load and geometry were shared in a database with the structural engineers. Whenever data changed, a new analysis could be performed swiftly without retyping a lot of data.

The weakest soil strength within a depth corresponding to the width of the footing was used as a conservative first estimate representative for each pier. Those piers not fulfilling DS 415 (1984) with this approach were analysed with a method applying the local soil strength at each part of the rupture figure for the critical load cases.

3.4.2 ALS - Accidental Limit State (Ship impact analyses)

Ship impact analyses were addressed within a framework of probabilistic analyses. The consequences of impacts from ships of different sizes and velocities were charted, using a computer program, SIAS62, to generate results for the probabilistic analyses. The ship impact analysis was performed taking the total construction into account: Pier, bridge girder, neighbouring piers and soil, thus permitting the whole construction to absorb an impact. The soil is modelled by simple linear elastic, ideally plastic springs for deflection in three directions as well as in torsion. These springs only model soil layers in relatively close contact with the foundation whereas the far field effects are not modelled.

For the soil part of the analysis an independent 3D finite element analysis, using the FENRIS program, was decided upon since a control calculation by hand was considered very time consuming or even impossible. Feld and Gravgaard (1994) describe this analysis in more detail.

3.4.3 SLS - Serviceability Limit State

The challenge of the SLS analysis was to perform an analysis true to the nature of the clay till. A calculation method was prepared, fully implementing the SHANSEP strength and stress model with Bjerrum's concept of primary and secondary consolidation. The application of the different loading-unloading schemes during the different stages of construction could be modelled while at all times keeping track of consolidated strength, preconsolidation and displacements.

A database was developed with the design soil profiles for the piers. Also a reference to the loads and geometries database was used. Then, for each pier, a load-settlement prediction could be carried out. All layers, down to the marl, were modelled with settlement parameters representative of the soil type and its initial stress and strength data. For the clay till a dramatic increase in settlement (creep) occurred when a limit of approximately 70% of the preconsolidation stress, σ'_{pc} , was exceeded.

3.5 Approach ramps

In Halsskov on Sjælland the natural topography allows almost direct access to bridge level, whereas a man made embankment rising some 24 m above sea level was necessary on Sprogø. This, however, introduced a unique possibility for full

scale testing of the settlement and creep model established for the clay till based on laboratory tests from the West and East Bridge projects.

Settlement gauges were installed in the base of the embankment, in the underlying clay till and finally below the clay till in the marl. Monitoring of these gauges are still on-going (fifth year).

4. LESSONS LEARNED

The experiences from this project may be summarised as follows:

- A comprehensive geological model is necessary for proper correlation of even the most detailed and advanced testing programme.
- Modern data handling and statistical methods are required for such complicated conditions and these may lead to much more rational design procedures.
- CPT testing is a good tool for obtaining detailed strength information with depth for the encountered till formations.
- Large scale laboratory tests and in situ tests are absolutely necessary.
- Compacted layers of crushed rock gravel only show dilatancy very late in a failure process at high stress level. Such a layer may in this context be considered ductile.
- Control of skirt penetration into gravel pads of crushed rock is feasible by introduction of an upper, uncompacted gravel layer with a carefully selected thickness.
- Remoulded clay till will gain an undrained shear strength of 0.35 times the consolidation pressure for normal loading rates (0.45 for high loading rates). This strength includes the effects of consolidation and ageing but not any effect of shear deformations.
- Completely independent geotechnical analyses must be performed for such important and complicated structures, especially when applying modern *black box* computer systems. This is considered the most important quality control measure.

In conclusion, the overriding message from the project is that very close co-operation between geotechnical engineers, structural engineers and engineering geologists is a prerequisite for success.

Only by interaction within the different disciplines and by testing in different scales, numerically as well as physically, can we be sure to obtain safe and cost effective solutions and hope to advance the state-of-the-art.

7. REFERENCES

- [1] DGI POS 130 (1991). Digest of Field and Laboratory Information on Sliding Resistance. Danish Geotechnical Institute, dated 1991-08-16, DGI job No 180 06510.
- [2] DS 415 (1984). *Code of Practice for "Foundation Engineering"*, 3. edition, February 1984, DS 415. Translation into English, Danish Technical Press, Copenhagen (also Danish Geotechnical Institute, DGI Bulletin 36, 1984).
- [3] Feld, T. and Gravgaard, J.H. (1994). Analysis of an Eccentric Ship Impact. *Proc. of the XIII Int. Conf. Soil Mech. Fndn. Eng.*, New Delhi, Vol 4, pp. 1687-1690.
- [4] Foged, N., Larsen, B., Larsen, G., Thomsen, E. (1995). An overview on engineering geological conditions at Storebælt. *Proc. 11th Eur. Conf. Soil*

Mech. Fndn. Engn., Copenhagen, 28 May - 1 June 1995, Danish Geotechnical Society, Bulletin 11, Vol 5.

- [5] Hansen, P. Bjerregaard, Denver, H. and Mollerup, E. (1991). Lateral sliding resistance. Deformation of Soils and Displacement of Structures. X ECSMFE, Firenze, pp 433-436.
- [6] Ibsen, L.B. (1994). The stable state in cyclic triaxial testing on sand. *Soil Dynamic and Earthquake Engineering*, 13, pp. 63-76.
- [7] Larsen, G., Baumann, J., Tychsen, J. (1982). *Storebælt, geological relations of the Eastern channel*. Danish Geotechnical Institute, DGI Bulletin No 34, 79 pp.
- [8] Mortensen, J. Kammer, Hansen, G., Sørensen, B.(1991). Correlation of CPT and Field Vane Tests for Clay Tills. *DGF Bulletin No. 7*, Danish Geotechnical Society, 89 pp.
- [9] Mortensen, K. (1983). Is Limit State Design a Judgment Killer? The Sixth Laurits Bjerrum Memorial Lecture. *Norwegian Geotechnical Institute. Publication No. 148*, Oslo 1983.
- [10] Steenfelt, J.S., Foged, N. (1992). Clay till strength - SHANSEP and CSSM. *Proc. NGM-92*, Aalborg, Danish Geotechnical Society, Bulletin 9, Vol 1, pp. 81-86.
- [11] Steenfelt, J.S. (1993). Sliding resistance for foundations on clay till. *Wroth Memorial Symposium, Oxford. Predictive soil mechanics*. Thomas Telford, London, pp 664-684.
- [12] Steenfelt, J.S., Haahr, F., Jensen, J.E. (1994). Shear transfer through stone wedge to clay interface. *Proc. XIII Int. Conf. Soil Mech. Fndn. Eng.*, New Delhi, Vol 2, pp. 729-732.
- [13] Steenfelt, J.S. and Foged, N. (1994). Dilational behaviour of crushed stone. *Proc. 7th Congress of the Int. Ass. of Eng. Geology*, Lisbon, Vol V, pp. 3357-3364.
- [14] Sørensen, C.S., Clausen, C.J.F., Andersen, H. (1993). Bearing Capacity Analyses for the Great Belt East Bridge Anchor Blocks. *Limit state design in geotechnical engineering, ISLSD 93*, Copenhagen, Danish Geotechnical Society, Bulletin 10, Vol 1, pp 305-312.