



AALBORG UNIVERSITY
DENMARK

Aalborg Universitet

Hearing Thresholds and Equal Loudness Contours in Free Field at Frequencies below 1 kHz

Watanabe, Toshio; Møller, Henrik

Published in:
Journal of Low Frequency Noise, Vibration and Active Control

Publication date:
1990

Document Version
Accepted author manuscript, peer reviewed version

[Link to publication from Aalborg University](#)

Citation for published version (APA):
Watanabe, T., & Møller, H. (1990). Hearing Thresholds and Equal Loudness Contours in Free Field at Frequencies below 1 kHz. *Journal of Low Frequency Noise, Vibration and Active Control*, 9(4), 135-148.

General rights

Copyright and moral rights for the publications made accessible in the public portal are retained by the authors and/or other copyright owners and it is a condition of accessing publications that users recognise and abide by the legal requirements associated with these rights.

- ? Users may download and print one copy of any publication from the public portal for the purpose of private study or research.
- ? You may not further distribute the material or use it for any profit-making activity or commercial gain
- ? You may freely distribute the URL identifying the publication in the public portal ?

Take down policy

If you believe that this document breaches copyright please contact us at vbn@aub.aau.dk providing details, and we will remove access to the work immediately and investigate your claim.

Hearing Thresholds and Equal Loudness Contours in Free Field at Frequencies Below 1 kHz

Toshio Watanabe* and Henrik Moller

*Institute of Electronic System, Aalborg University, Fredrik Bajers Vej 7,
DK-9220 Aalborg Ø, Denmark.*

(Received April 3rd 1991)

Abstract

Hearing thresholds for pure sinusoidal tones were determined in a free field at frequencies from 25 Hz to 1 kHz. Contours of equal loudness were determined at the same frequencies at loudness levels from 20 phon to 80 phon in steps of 20 phon. 12 subjects participated.

The psychometric method used for the threshold determinations was the method of limits. The deviations from minimum audible field values given in ISO/R226 were small (3 dB at most frequencies).

For the measurement of equal loudness the reference was a 1 kHz tone, and other tones were compared to that. The psychometric method was the method of limits. The resulting equal loudness contours were positioned at much higher levels than those of ISO/R226. Similar results have recently been reported by others. At low loudness levels the results were in good agreement with the curves obtained by Fletcher and Munson, but at high loudness levels they were also above their curves.

Some of the points of equal loudness were also determined by a maximum likelihood estimation method. The results differed slightly from those obtained by the method of limits.

1. Introduction

Contours of equal loudness and thresholds of hearing have been given by H. Fletcher and W.A. Munson [1], B.G. Churcher and A.J. King [2], D.W. Robinson and R.S. Dadson [3], B.A. Kingsbury [4], J.L. Sivian and S.D. White [5] and other investigators. The results of Robinson and Dadson were adopted as ISO/R226 in 1961 [6], and that has been used as a standard of hearing thresholds and curves of equal loudness for pure tones up to the present.

A previous study by one of the authors of the present article included measurement of equal loudness levels at 63 Hz and 31.5 Hz [7]. The resulting values were significantly different from the values in ISO/R226. They were 2-12 dB higher than in ISO/R226, and no explanation was found.

At the Budapest meeting in 1985 of ISO/TC 43/WG 1 concerning "threshold of hearing", additional new data different from ISO/R226 were reported, and a revision of the standard was decided. Following that meeting of the same working group was held in Copenhagen in 1987, and the procedures for measurement of hearing thresholds and curves of equal loudness were discussed. A new set of experimental conditions to be fulfilled in future measurements was proposed. The proposal was slightly revised at the working group meeting in Toronto 1988.

After the decision to revise ISO/R226 new results were reported by Suzuki *et al.* [8]. These were also not coincidental to ISO/R226. There were large discrepancies. The new results were more similar to Fletcher and Munson's results. The possibility exists that the reasons for the discrepancies are the electronic equipment, the psychometric method, the sound field conditions and other experimental conditions. Therefore, additional new data are required to establish permanent standards of equal loudness and minimum audible field.

The purpose of the present work is to give new data on minimum audible field and equal loudness in the low frequency range. The experimental conditions agree with the requirements set up by ISO/TC 43/WG 1.

* Now at Fukushima National College of Technology, Iwaki, Fukushima 970, Japan.

2. Sound Field

The experiments were carried out in the anechoic room at the Institute of Electronic Systems, Aalborg University. The size of the room is 4.9 m by 5.6 m by 6.0 m (free space between wedges).

2.1 Loudspeakers

In this study subjects were to be exposed to pure tones in the frequency range 25 Hz-1 kHz. Also direct comparisons would be made between a 1 kHz reference tone with fixed sound pressure, and a test tone with a variable level and with frequencies between 25 Hz and 1 kHz. A sound source covering this frequency range was needed.

Very high sound pressure levels were required at low frequencies. When a high sound pressure is generated by electrodynamic loudspeakers, large harmonic distortion will be produced, especially at low frequencies. Harmonic distortion disturbs the accurate measurement of hearing thresholds and equal loudness, since the higher harmonics appear at frequencies where the ear is more sensitive, because of the negative slope of the curves versus frequency. Therefore, the harmonic distortion should be kept low.

Determination of the hearing threshold at 25 Hz demands the lowest distortion. Here, second harmonic distortion below -33 dB relative to the fundamental and third order distortion below -44 dB is considered necessary. If the slopes of ISO/R226 are correct, these figures ensure that the harmonics are at least 10 dB below threshold. At higher loudness levels and at higher frequencies a higher distortion is acceptable, since the curves become less steep.

Eight electrodynamic loudspeakers were used, mounted four in each of two enclosures. The dimensions of one enclosure were 0,78 m (W) by 0.74 m (H) by 0.42 m (D). The loudspeakers could not be used for threshold determinations below 25 Hz. At this frequency a threshold around 65 dB SPL was expected, and the requirement of a second harmonic distortion 33 dB down was fulfilled up to SPLs of 80 B. Above 40 Hz the loudspeakers were only used at levels where the second harmonic distortion was at least 40 dB down.

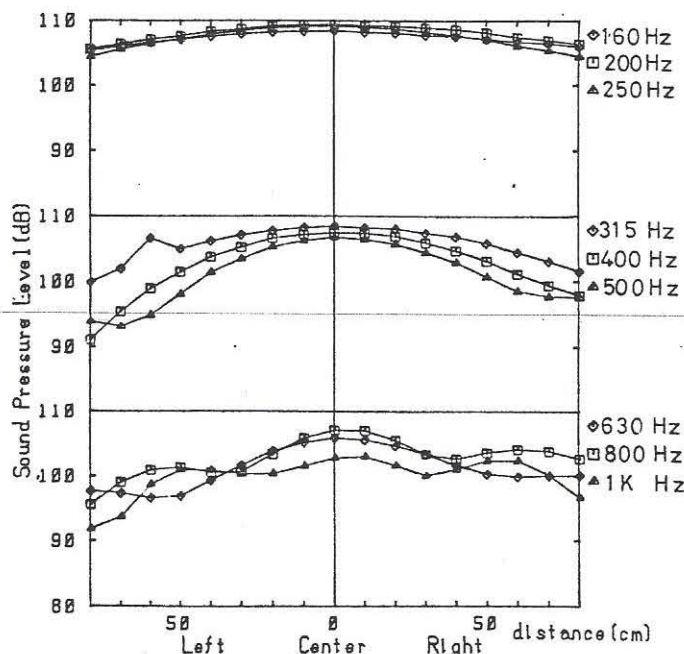

Figure 1. The sound distribution in front of the 8 loudspeakers along a horizontal axis parallel to the loudspeaker front board and 2m away.

2.2 Sound distribution from the loudspeakers

As mentioned above, eight loudspeakers were used to produce the sound. When a sound is generated from many sources at the same time, interference will occur, and the sound may not spread uniformly in front of the loudspeakers. If an extremely high

or low sound level appears around the measurement points, it will disturb the experiments.

Figure 1 shows the sound distribution in front of the loudspeakers along a horizontal axis parallel to the loudspeaker front board. The signals are pure tones at various frequencies. The sound distribution is quite good at frequencies below 500 Hz, but it is not uniform over 500 Hz. The figure shows the sound distribution is asymmetrical in front of the loudspeakers, and the sound does not spread concentrically at these frequencies.

A more detailed analysis was carried out on the field around the reference point, where the subject's head was going to be during the threshold and loudness determinations. The levels at positions ± 0.15 m away from the reference point on the left-right, forward-backward and up-down axis were measured. The deviations from the level in the reference point were very small and never exceeded 1 dB, except for one point where the deviations at 800 and 1000 Hz were 1.2 dB and 1.6 dB. With these deviations the sound distribution as expected to be good enough for the measurements. This matter is further evaluated in Section 3.

2.3 Background noise

Background noise in the anechoic room was extremely low even when the ventilation system was turned on. When the power amplifier was connected to the loudspeakers and the power turned on, the loudspeakers generated a very soft hum noise. Figure 2 shows the background noise including the loudspeaker hum measured in front of the loudspeakers at the head position of a subject.

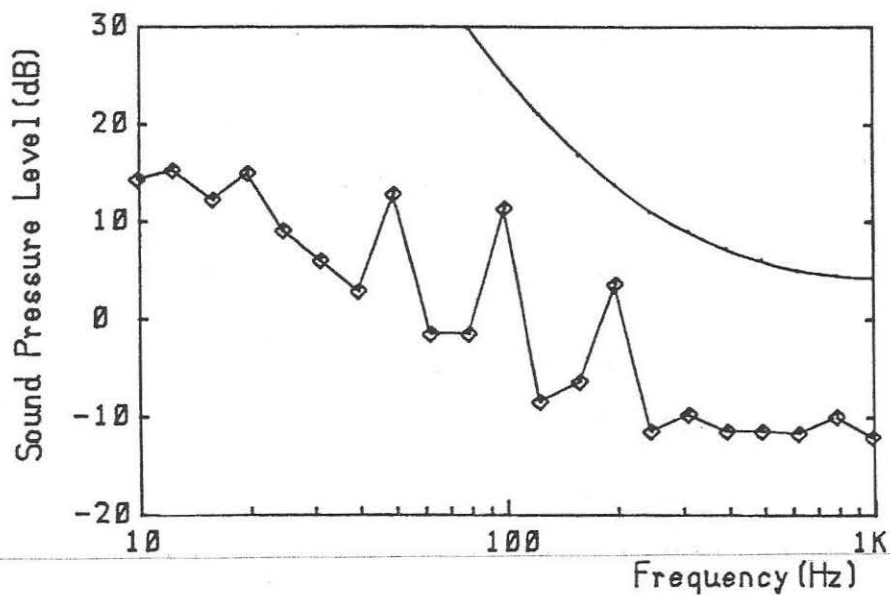

Figure 2. Background noise in the anechoic room. Measured with Bruel and Kjaer equipment: microphone 4179, preamplifier 2660, analyzer 2131. The continuous line is the minimum audible field of ISO/R226.

Sound pressure levels at 50 Hz, 100 Hz and 200 Hz are higher than the levels at adjacent frequencies. Sound at these frequencies originate from hum in the power amplifier. But the levels are still 28 dB, 13 dB and 10 dB lower than the minimum audible field of ISO/R226, and the noise will not influence the results of threshold and loudness measurements.

2.4 The effect of the presence of a curtain

To prevent the subject from being disturbed by seeing the equipment in the anechoic room and possibly watching the membranes moving, a white curtain was hung between the loudspeakers and the subject.

The disturbance of the sound field from the curtain was measured in the following way: The frequency response of a small loudspeaker was measured with and without

the curtain. The loudspeaker was at the same position as the large loudspeaker boxes would be during the experiments, and the response was measured at the head position.

The curves with and without the curtain were equal within fractions of a dB at frequencies up to 4 kHz. Considering that the curtain was present also during calibration of the sound level, the curtain introduced no error.

3. Evaluation of the Sound Field with a Head and Torso Simulator

The correct sound field is very important for the measurement of threshold and loudness. The sound pressure levels in ISO/R226 are not given as levels at the eardrum, but as levels in a free horizontal sound wave, measured before the subject enters the sound field. In the present experiments - as well as in others - a perfect free plane wave is not created. It is therefore essential to prove that the diffraction around the head and body is similar to the diffraction in a free plane wave or at least that the sound arriving at the ear is similar to that which would arrive, if the field were a free plane wave.

The sound field was controlled by means of a Bruel and Kjaer head and torso simulator, type 4128 and ear simulator, type 4159 mounted as the left ear.

3.1 Reference situation: subject in a free plane wave

The head and torso simulator was located two metres in front of a small loudspeaker in the anechoic room. The loudspeaker can be seen as a point source and at a distance of 2 m the field is nearly plane. With white noise applied to the loudspeaker, and utilizing a Bruel and Kjaer type 2032 two channel FFT analyzer, the transfer functions were measured to 1) the head position without the head and torso simulator, and - with the simulator positioned as subject - 2) the entrance to the ear canal and 3) the eardrum of the simulator. The difference between 2) and 1) at the one third octave frequencies is shown in Figure 3.

The difference of the sound pressure levels between the pinna and the head position were almost zero at frequencies below 300 Hz, but increased as the frequency increased over 300 Hz. This means that the sound pressure level at the pinna was higher than that of the head position due to the sound reflection from the pinna and the head in this frequency range.

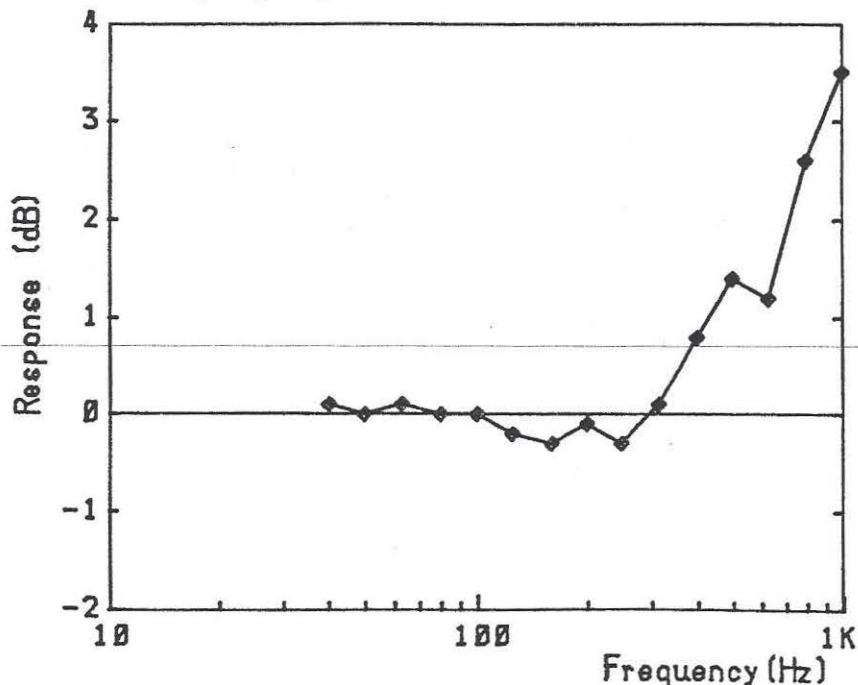

Figure 3. Difference of the sound level at the pinna and at the head position without subject. Measured with a small loudspeaker as sound source and the head and torso simulator at 2 m distance.

As the sound field used for the results in Figure 3 is considered as a horizontal free travelling wave, this figure is the reference which should preferably be obtained also with the large loudspeaker boxes used for presenting the stimuli for the subjects. (Of

course, the sound field is only approximately a plane wave. To control this approximation, the measurements were also made at larger distances, but the results did not change. At shorter distances the results became different).

3.2 Subject in sound field produced by eight loudspeakers

The measurements described above in Section 3.1 were repeated, though this time the small loudspeaker was replaced by the large boxes with 8 loudspeakers. The curtain mentioned above in Section 2.4 was positioned between the loudspeakers and the head and torso simulator. The difference between the "pinna level" and the "head position level" is given in Figure 4.

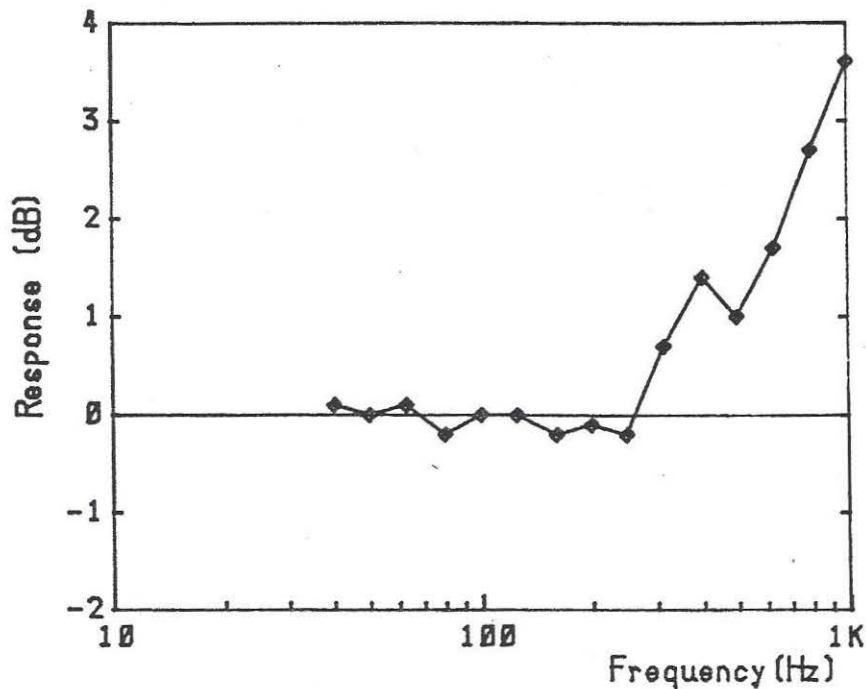

Figure 4. Difference of the sound level at the pinna and at the head position without subject. Same as Figure 3 but measured with the 8 loudspeakers as sound source.

Similar data measured with the small loudspeaker were given in Figure 3. Comparing the data from the eight loudspeaker situation to the situation with the small loudspeaker only minor differences can be seen. They are all far below 1 dB at frequencies up to 1 kHz. On this background the sound field produced by the eight loudspeakers is considered sufficiently good for the threshold and loudness measurements.

3.3 Influence of the chair

During the experiments, the subjects were going to sit on a chair. As the sound field might be disturbed by the chair, this disturbance was measured using a procedure similar to the above. Two different chairs were used, one was very light and small and the other was rather big. The torso was put on the chair 2m in front of the loudspeakers. The frequency responses were measured as in Section 3.1 and 3.2. For the two chairs, the difference between sound level at pinna and at the head position is shown in Figure 5.

In this figure the values from the big chair are different from those from the small one, especially at 800 Hz. Not unexpectedly, the big chair disturbs the sound field more than the small one. The values for the small chair are close to the reference values in Figure 3. Therefore the small chair was selected.

The difference between the sound level at the pinna and at the eardrum was almost the same in all situations. This was expected, since the sound propagation from the pinna to the eardrum should be the same, independent of the origin of the sound and the diffraction around the listener.

Figure 6 shows a view of the loudspeakers, the curtain the chair used in the experiment.

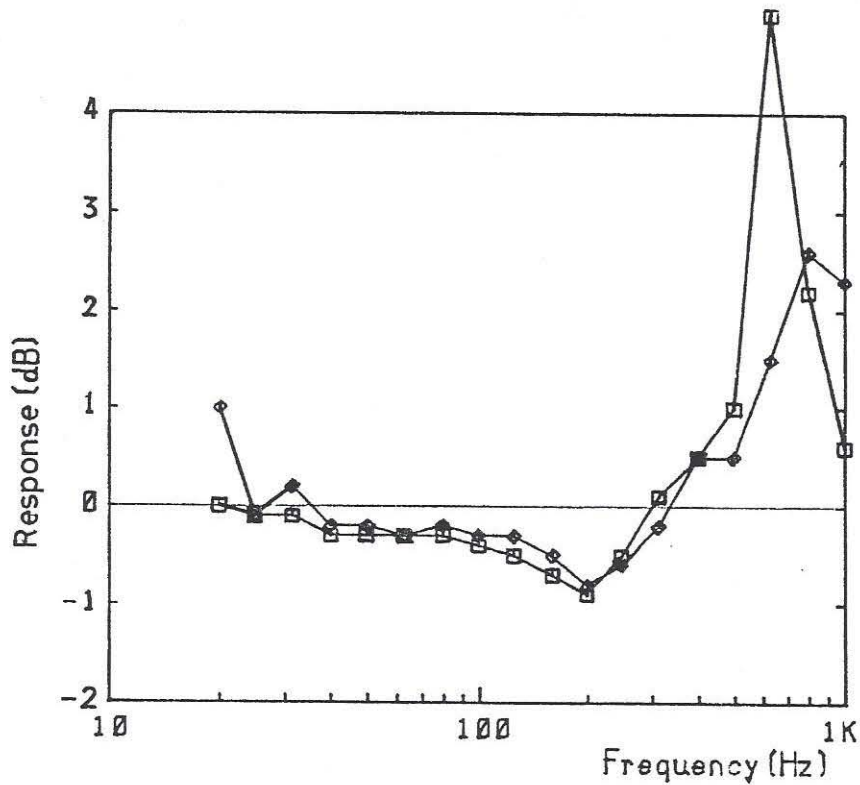

Figure 5. Difference of the sound level at the pinna and at the head position without subject. Measured at the head and torso simulator placed on a small chair (\diamond) or a big chair (\square) and 8 loudspeakers as sound source.

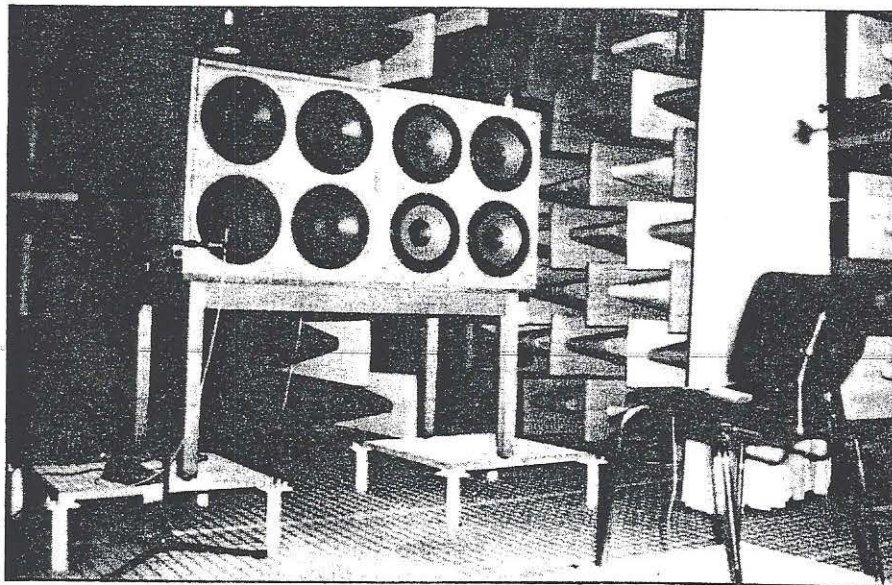

Figure 6. A view of the loudspeakers and the chair used for the experiments. The curtain displaced to show the loudspeakers.

4. Experiment

4.1 Equipment

A schematic diagram of the equipment is shown in Figure 7. The computer (Metric 8) was connected to a sine generator (Bruel and Kjaer 1049) by an IEEE-488 interface

with the attenuator (custom made) by parallel input/output lines (PIO), and with the answering box (custom made) by PIO. The attenuator had an on-off switch and gave the attenuation with 1 dB resolution, 0.2 dB accuracy, from 0 dB to -115 dB. The attenuation level was chosen to produce the required level from the loudspeaker.

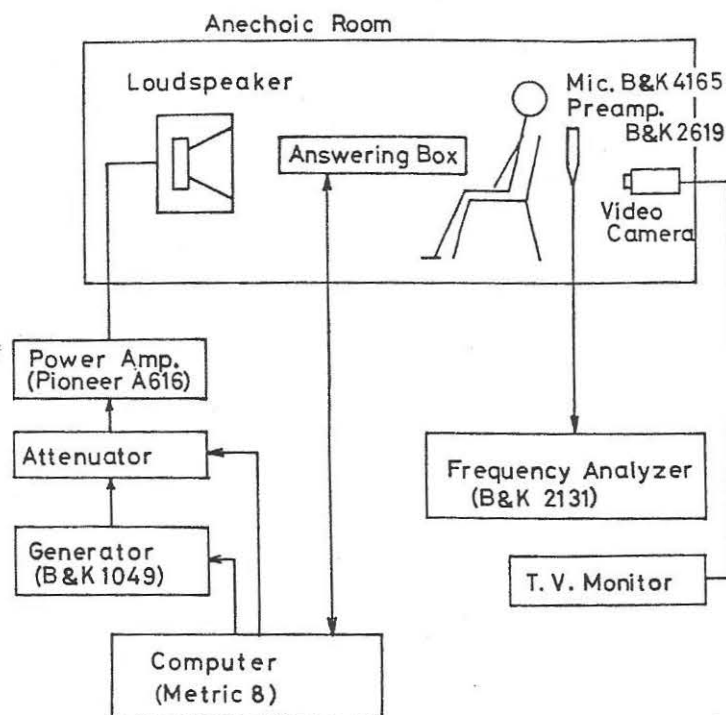

Figure 7. Schematic diagram of the experiment.

The curtain was hung between the loudspeakers and the subject. The subject could not see any of the apparatus except for a video camera monitoring the subject, and only one spot-light was used to light up the subject area inside the anechoic room. Therefore the subject could easily concentrate on listening to the sound without any distractions.

The power amplifier, the microphone preamplifier, the frequency analyzer and the attenuator were switched on during the experiment for about three weeks. So the whole system was very stable.

4.2 Sound stimuli

Pure sinusoidal tones were used as sound stimuli. In the measurement of hearing thresholds tones with a duration of 1 s were presented alternating with 1 s pauses. The tones were turned on and off gradually within approximately 0.25 s. The frequencies were at every $\frac{1}{2}$ octave band from 25 Hz to 125 Hz, and at every octave band from 125 Hz to 1 kHz - eleven points.

In the measurement of equal loudness, pairs of tones were presented; one was a reference tone at 1 kHz and the other was the test tone with variable sound level. The duration of each tone and the interval between them was one second. The order of the tones was chosen randomly. The tones were turned on and off gradually in approximately 0.25 s.

The 1 kHz reference tone had levels of 20, 40, 60 and 80 dB, so equal loudness levels of 20, 40, 60 and 80 phon were determined. Frequencies of the variable tones were 31.5, 40, 50, 63, 80, 100, 125, 250 and 500 Hz.

At 31.5 Hz only the 20 phon point was measured because of the high harmonic distortion levels from the loudspeakers at higher levels. For the same reason only 20 and 40 phon points were measured at 40 Hz.

4.3 Psychometric method for threshold measurements

The psychometric method used was the method of limits (ML). The first presented sound pressure levels were 10-20 dB higher than the hearing threshold of ISO/R226. At

this level most subjects could hear the sound clearly (if a subject did not hear the sound, the experiment was started again with a higher starting level). After the first sound, the level was gradually reduced in steps of 2 dB. When the subject did not hear anything he/she pressed the button on the answering box, and the series of descending levels stopped. From this series the average of the last two presented levels was recorded as a turning point.

Then followed a series of ascending levels, beginning 4-5 dB below the last level from the previous descending series. With this starting level, the subjects could not hear the tone at first. The level was gradually increased in 2 dB steps, and when the subject could hear the sound again, the button on the answering box was pressed. Also here the average of the last two levels was recorded as a turning point.

The third series was performed like the first series, though the starting level was now chosen 4-5 dB above the last level in the previous ascending series.

A total of 4 descending and 4 ascending series were carried out and the mean value of the 8 turning points - 4 from descending series and 4 from ascending series - was taken as the hearing threshold.

For each subject a test experiment was carried out before the beginning of the actual experiment. The frequency was chosen to be 1 kHz, since this is an easy frequency for the subjects and therefore it is adequate for familiarization with the method. The training points was repeated in the actual experiment.

4.4 Psychometric method for loudness measurements

Again the method of limits (ML) was used. For loudness comparisons, the method differed slightly from the above, so it will be described below.

Pairs of variable and reference tones were presented. The first level of a variable tone was 15-20 dB higher than the point of equal loudness given in ISO/R226. Normally the subjects assessed this tone as louder than the reference (if not, a higher level was selected, and the experiment started from the beginning again). The level of the variable tone was then gradually reduced in 2 dB steps, until the subject assessed the variable tone as softer than the reference tone and indicated this by pressing a button. The mean of the last two presentations in this descending series was recorded as a turning point.

Then followed an ascending series, where the level of the variable was turned up gradually in 2 dB steps. The starting point for this series was 4-5 dB below the last presentation in the previous descending series. When the subject assessed the variable louder than the reference he/she indicated that by pushing the button. Again, the average of the last two levels was recorded as the turning point.

Then followed another descending series, now beginning 4-5 dB above the last presentation of the previous ascending series.

Altogether 6 descending and 5 ascending series were carried out. The point of equal loudness was calculated as the mean of the turning points, excluding the first descending series.

The frequency of the variable tone and the level of the reference tone were chosen randomly among those listed in Section 4.2.

For each subject a test experiment was carried out before the beginning of the actual experiment. The frequency and the loudness level for the test experiment were 500 Hz, 40 phon (eleven subjects) or 250 Hz, 40 phon (one subject). These frequencies and levels were chosen, because they were easy for the subjects and therefore adequate for familiarization with the method. The training points were repeated in the actual experiment.

For seven subjects a maximum likelihood estimation method (MML) was also used for some selected points (20 and 40 phon at 63, 125 and 250 Hz). The maximum likelihood estimation method was exactly the same as in the previous experiment reported by one of the authors [7]. The experiments using this method were carried out after the main experiment.

Figure 8 shows a view of a subject during the experiment.

4.5 Calibration

The system was calibrated at the beginning of the experiment. For each frequency the sound pressure level was measured at the head position of a subject without subject and chair. These levels were calibration levels. They were fed into the computer program, and based upon these levels, all attenuator settings during the experiment

were determined.

The calibration levels were re-measured every day at the beginning of the experiment. If differences were found the calibration levels were changed. Only changes in the order of small fractions of a dB occurred, probably because the equipment was turned on all the time for the whole experimental period.

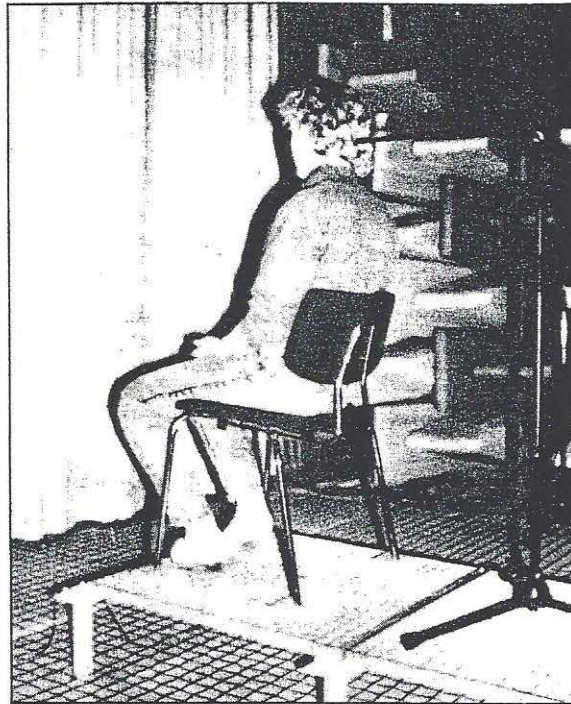

Figure 8. A subject during the experiment.

4.6 Subjects

Twelve persons were used as the subjects. There were five females and seven males, between the age of 18 and 30. The average age was 23.2 years. Monaural hearing thresholds were measured with an audiometer before the experiment. It was ensured that the thresholds of each subject were within ± 10 dB at the octave frequencies from 125 Hz to 4 kHz and ± 15 dB at 8 kHz.

5. Results

The minimum audible field is given in Table I, and the points of equal loudness are given in Table II. Values in brackets are obtained for seven subjects only using the method of maximum likelihood. All results are shown graphically in Figure 9.

TABLE I
Hearing thresholds in free field

Frequency (Hz)	Mean value (dB)	Standard deviation (dB)	Number of subjects
25	68.5	5.7	12
31.5	60.3	6.8	12
40	51.2	5.8	12
50	45.7	6.0	12
63	38.4	6.5	12
80	32.3	6.4	12
100	28.3	5.7	12
125	24.7	6.0	12
250	11.8	5.1	12
500	5.4	4.0	12
1000	-1.7	3.7	12

TABLE II
Equal loudness levels

The data in round brackets were obtained by the method of maximum likelihood.

Loudness (phon)	Frequency (Hz)	Mean value (dB)	Standard deviation (dB)	Number of subjects
20	31.5	79.8	3.8	12
20	40	72.9	6.4	12
20	50	71.6	5.7	11
20	63	65.7	6.7	12
20	63	(60.8)	(7.1)	(8)
20	80	59.8	5.1	12
20	100	58.0	5.2	12
20	125	50.8	3.7	12
20	125	(47.1)	(6.3)	(8)
20	250	36.9	6.3	12
20	250	(35.7)	(4.1)	(8)
20	500	30.2	5.2	12
40	40	87.9	2.4	12
40	50	84.9	4.6	12
40	63	81.4	5.2	12
40	63	(75.9)	(4.5)	(8)
40	80	77.4	5.4	12
40	100	73.9	5.5	12
40	125	68.1	4.6	12
40	125	(66.9)	(4.4)	(8)
40	250	61.0	3.4	12
40	250	(52.8)	(2.7)	(7)
40	500	50.9	5.9	12
60	50	95.8	5.0	12
60	63	93.3	5.1	12
60	80	89.4	4.4	12
60	100	85.8	3.1	12
60	125	83.7	3.5	12
60	250	76.1	3.9	12
60	500	66.8	3.1	12
80	50	101.5	5.1	10
80	63	100.3	2.6	10
80	80	101.6	3.8	11
80	100	97.0	3.3	12
80	125	97.0	3.7	12
80	250	90.7	4.0	12
80	500	85.0	2.9	12

Discussion

6.1 Reproduceability

The hearing threshold at 1 kHz was measured twice; once in the training experiment and once in the main experiment. The average threshold found in the training experiments was 0.0 dB with a standard deviation of 3.7 dB. In the main experiment an average of -1.7 dB was found with a standard deviation of 3.6 dB. The values are in very good agreement, and as could be expected a t-test was far from showing significance ($t=1.14$). The reproduceability seems to be very good.

Although the simple t-test did not show any significant difference between the two measurements, a look at every subject shows that the values from the second measurement were always lower than or equal to the values from the first one. This may suggest that the subjects gradually got used to the sound or the method and obtained increas-

HEARING THRESHOLDS BELOW 1 kHz

ing sensitivity throughout the experiment.

For equal loudness, test measurements were carried out before the main experiment. For the 10 subjects who had 500 Hz, 40 phon in the test, an average value of 49.8 dB and a standard deviation of 3.5 dB was found. In the main experiment the corresponding values were 50.6 dB and 6.0 dB. No specific tendency was seen here. It can be concluded that also the reproducibility of the equal loudness determinations was good.

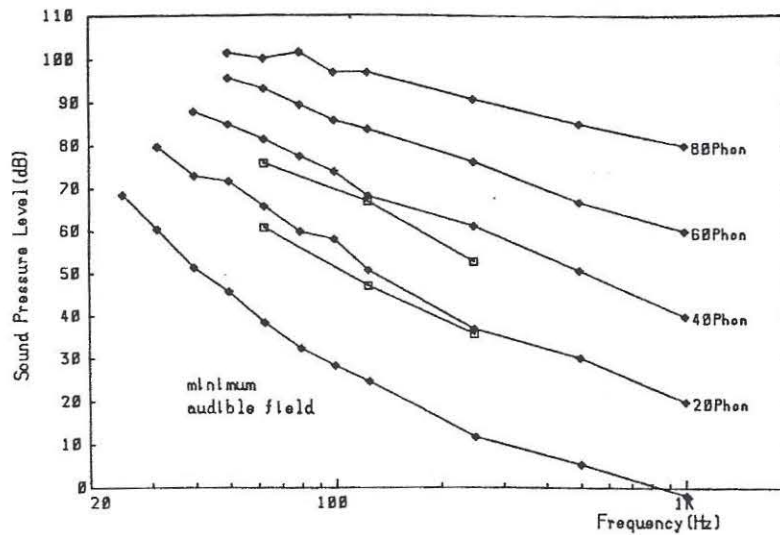

Figure 9. Minimum audible field and equal loudness contours. The present study by the method of limits (\diamond) and the method of maximum likelihood (\square).

6.2 Comparison of the two methods

In order to show a possible effect of the psychometric method, another method, the method of maximum likelihood, was used for selected points. The results given in Table II and Figure 9 shows lower values for the method of maximum likelihood. However, not all subjects participated in both methods, so the values given are not based on the same group.

To see whether the difference between results of the two methods is statistically significant, an analysis of variance is carried out for the 7 subjects who participated in both methods. The independent variables are 1) frequency, 2) loudness level and 3) method. The results of a simple analysis are shown in Table III column a).

TABLE III

Significance levels from analysis of variance for the 7 subjects who participated in both methods (ML and MML). Column a) is obtained in a simple analysis of variance and column b) in a mixed model with subject as random variable.

Source	a)	b)
loudness level	<0.001	<0.001
frequency	<0.001	<0.001
method	0.0015	n.s.
loudness level x frequency	0.027	<0.001
loudness level x method	n.s.	n.s.
frequency x method	n.s.	n.s.
loudness level x frequency x method	n.s.	n.s.

The effect of the method is found significant at 1.5% level. However, it may be argued that the observations are not statistically independent, since they are obtained from a particular group of subjects. A more conservative test will therefore be that of a mixed model with subject as a fourth independent variable of the random type. The result of this analysis is shown in Table III, column b). Here the effect of the method is not significant.

HEARING THRESHOLDS BELOW 1 kHz

For both methods, main effects of loudness level and of frequency are highly significant. This will not surprise anyone. Also interaction is shown between loudness level and frequency. This illustrates the non-linearity of the equal loudness curves.

6.3 Comparison with our previous results

In the previous study by one of the authors [7], equal loudness levels were obtained by the same maximum likelihood estimation method. Two points are included in the present investigation as well as in the previous study. The results at 20 phon, 63 Hz are 58.0 dB (previous) and 60.2 dB (present), and at 40 phon, 63 Hz results are 71.7 dB (previous) and 75.9 dB (present). These differences are small and not statistically significant in a t-test ($t=1.6$ for the 4.2 dB difference). Thus, a good agreement was found between results in this and the previous study.

6.4 Comparison with ISO/R226

Our threshold curves and our equal loudness contours are shown together with curves from ISO/R226 (Figure 10) and Fletcher and Munson (Figure 11).

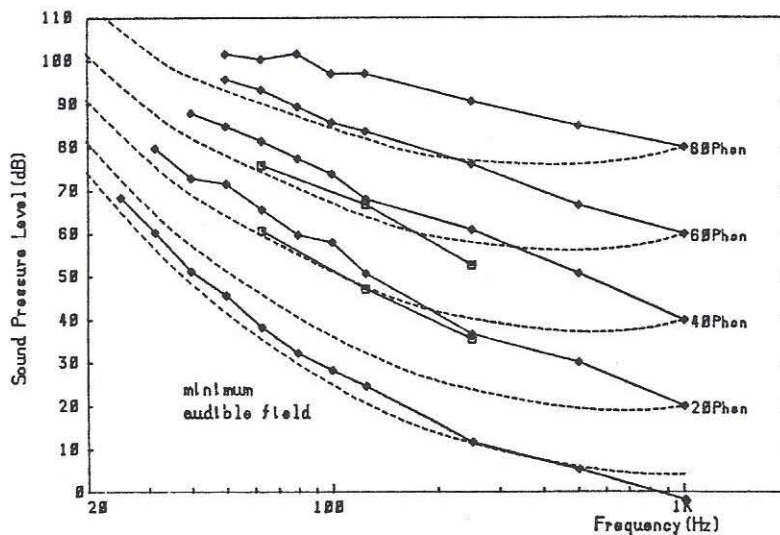

Figure 10. Results of present study compared to ISO/R226 (dotted lines).

The hearing thresholds in free field found in the present experiment are almost along the minimum audible field of ISO/R226 although the values of the present study are about 3 dB higher at frequencies below 125 Hz and 5.9 dB lower at 1 kHz.

With 12 subjects and a typical standard deviation of 6 dB, a 3 dB deviation from a fixed value (like the ISO/R226 values) results in a t-test value of 1.73 – just about significant at the 5% level. The deviation at 1 kHz is significant at the 0.1% level ($t=5.5$).

Equal loudness contours from the present study are much higher than those of ISO/R226 at all frequencies. They are closer to Fletcher and Munson's results. Most of the discrepancies from ISO/R226 are more than 10 dB and some of them are more than 20 dB. Most of the differences are statistically significant.

One of the authors already reported equal loudness levels that were higher than those of ISO/R226. The results of the present study show the same tendency as the previous study. It seems that discrepancies clearly exist between the equal loudness levels of ISO/R226 and accurate equal loudness levels.

The authors have not been able to explain why different studies of equal loudness can show such very different results. In this study every care has been taken to document all the experimental conditions. It is shown that the psychometric method may affect the results, but the influence in this study was only around 3 dB.

HEARING THRESHOLDS BELOW 1 kHz

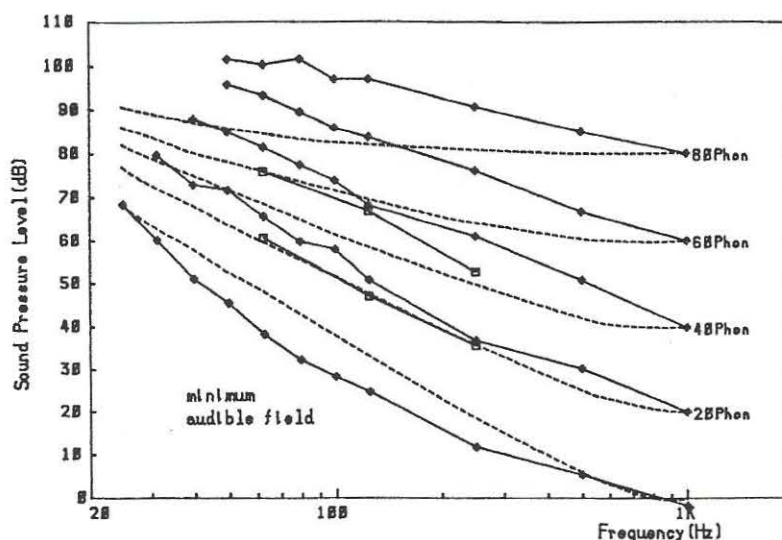

Figure 11. Results of a study compared to the results of Fletcher and Munson [1] (dotted line).

7. Conclusion

The hearing thresholds were determined in free field at frequencies from 25 Hz to 1 kHz. At frequencies at or below 125 Hz the curve was parallel to the curve of ISO/R226. The values were slightly but significantly higher (about 3 dB). At 1 kHz the threshold was found 5.9 dB lower than indicated in ISO/R226. This difference was also statistically significant.

New data for equal loudness contours in free field were determined at frequencies from 31.5 Hz to 1 kHz, at loudness levels from 20 phon to 80 phon every 20 phon step. Compared with the data of ISO/R226, the levels were much higher at all loudness levels. The differences were statistically significant. Though every possible care was taken in the control of sound field, procedure etc., the results of the equal loudness measurements turned out to be higher. Similar results have previously been reported by one of the present authors and by several others.

References

1. H. Fletcher and W.A. Munson, "Loudness, its Definition, Measurement and Calculation", *Journal of the Acoustical Society of America*, Vol. 5, 82-108 (1933).
2. B.G. Churcher and A.J. King, "The Performance of Noise Meter in Terms of the Primary Standard", *Journal of the Institute of Electrical Engineers*, Vol. 81, 57-90 (1937).
3. D.W. Robinson and R.S. Dadson, "A Re-determination of the Equal Loudness Relations for Pure Tones", *British Journal of Applied Physics*, Vol. 7, 166-181 (1956).
4. B.A. Kingsbury, "A Direct Comparison of the Loudness of Pure Tones", *Physical Review*, Vol. 29, 588-600 (1927).
5. L.J. Sivian and S.D. White, "On Minimum Audible Sound Fields", *Journal of the Acoustical Society of America*, Vol. 4, 288-321 (1933).
6. ISO Recommendation R226, "Normal equal-loudness contours for pure tones and normal threshold of hearing under free field listening conditions" (1961).
7. H. Moller and J. Andresen, "Loudness of Pure Tones at Low and Infrasonic Frequencies" *Journal of Low Frequency Noise and Vibration*, Vol. 3, No. 2, 78-87 (1984).

8. S. Suzuki, Y. Suzuki, S. Kono, T. Sone, M. Kumagai, H. Miura, H. Kado, "Equal-loudness level contours for pure tone under free field listening conditions - (1) some data and consideration on experimental conditions", *Journal of Acoustical Society of Japan*, Vol. 10, No. 6 (1989).