

THE RELAXED AREA OF \mathbb{S}^1 -VALUED SINGULAR MAPS IN THE STRICT BV-CONVERGENCE*

GIOVANNI BELLETTINI^{1,2}, SIMONE CARANO³ AND RICCARDO SCALA^{1,**}

Abstract. Given a bounded open set $\Omega \subset \mathbb{R}^2$, we study the relaxation of the nonparametric area functional in the strict topology in $BV(\Omega; \mathbb{R}^2)$, and compute it for vortex-type maps, and more generally for maps in $W^{1,1}(\Omega; \mathbb{S}^1)$ having a finite number of topological singularities. We also extend the analysis to some specific piecewise constant maps in $BV(\Omega; \mathbb{S}^1)$, including the symmetric triple junction map.

Mathematics Subject Classification. 49J45, 49Q05, 49Q15, 28A75.

Received February 10, 2022. Accepted July 4, 2022.

1. INTRODUCTION

Let $\Omega \subset \mathbb{R}^2$ be a bounded open set and $v = (v_1, v_2) : \Omega \rightarrow \mathbb{R}^2$ be a map of class $C^1(\Omega; \mathbb{R}^2)$. The area functional $\mathcal{A}(v; \Omega)$ computes the 2-dimensional Hausdorff measure \mathcal{H}^2 of the graph

$$G_v := \{(x, y) \in \Omega \times \mathbb{R}^2 : y = v(x)\} \quad (1.1)$$

of v , a Cartesian 2-manifold in $\Omega \times \mathbb{R}^2 \subset \mathbb{R}^4$, and is given by the classical formula

$$\mathcal{A}(v; \Omega) = \int_{\Omega} \sqrt{1 + |\nabla v_1|^2 + |\nabla v_2|^2 + (\det \nabla v)^2} dx, \quad (1.2)$$

where

$$\det \nabla v = \frac{\partial v_1}{\partial x_1} \frac{\partial v_2}{\partial x_2} - \frac{\partial v_1}{\partial x_2} \frac{\partial v_2}{\partial x_1} \quad (1.3)$$

is the Jacobian determinant of v . Clearly, the integral in (1.2) is finite if $v \in W^{1,1}(\Omega; \mathbb{R}^2)$ and $\det \nabla v \in L^1(\Omega)$. As opposite to the case when the map is scalar-valued, the functional $\mathcal{A}(\cdot; \Omega)$ is not convex, but only polyconvex in ∇v , and its growth is not linear, due to the presence of $\det(\nabla v)$.

*We acknowledge the financial support of the GNAMPA of INdAM (Italian institute of high mathematics).

Keywords and phrases: Area functional, relaxation, Cartesian currents, total variation of the Jacobian, \mathbb{S}^1 -valued singular maps.

¹ Dipartimento di Ingegneria dell'Informazione e Scienze Matematiche, Università di Siena, 53100 Siena, Italy.

² International Centre for Theoretical Physics ICTP, Mathematics Section, 34151 Trieste, Italy.

³ Area of Mathematical Analysis, Modelling, and Applications, Scuola Internazionale Superiore di Studi Avanzati "SISSA", Via Bonomea, 265, 34136 Trieste, Italy.

** Corresponding author: riccardo.scala@unisi.it

An interesting problem is to try to extend $\mathcal{A}(\cdot; \Omega)$ out of $C^1(\Omega; \mathbb{R}^2)$: setting for convenience

$$\mathcal{A}(v; \Omega) := +\infty \quad \forall v \in L^1(\Omega; \mathbb{R}^2) \setminus C^1(\Omega; \mathbb{R}^2),$$

let us consider the sequential lower semicontinuous envelope

$$\overline{\mathcal{A}}_\tau(u; \Omega) := \inf \left\{ \liminf_{k \rightarrow +\infty} \mathcal{A}(v_k; \Omega) : (v_k) \subset C^1(\Omega; \mathbb{R}^2) \cap S, v_k \xrightarrow{\tau} u \right\} \quad \forall u \in S \quad (1.4)$$

of $\mathcal{A}(\cdot; \Omega)$ with respect to a metrizable topology τ on a subspace $S \subseteq L^1(\Omega; \mathbb{R}^2)$ containing those $v \in C^1(\Omega; \mathbb{R}^2)$ with $\mathcal{A}(v; \Omega) < +\infty$, and choose this as the extended notion of area.

A typical choice is $S = L^1(\Omega; \mathbb{R}^2)$ and τ the $L^1(\Omega; \mathbb{R}^2)$ topology, *i.e.*, $\overline{\mathcal{A}}_\tau = \overline{\mathcal{A}}_{L^1}$, a case in which little is known¹. It is not difficult to show that the domain of $\overline{\mathcal{A}}_{L^1}$ is properly contained in $BV(\Omega; \mathbb{R}^2)$, but its characterization is not available. Also, one can prove that

$$\overline{\mathcal{A}}_{L^1}(u; \Omega) \geq \int_{\Omega} \sqrt{1 + |\nabla u|^2} dx + |D^s u|(\Omega), \quad (1.5)$$

but the inequality might be strict [1, 7, 8]. Here ∇u is the approximate gradient of u , $|\cdot|$ is the Frobenius norm, $D^s u$ is the singular part of the distributional gradient Du of u , and $|D^s u|(\Omega)$ stands for the total variation of $D^s u$. Finding the expression of $\overline{\mathcal{A}}_{L^1}(\cdot; \Omega)$ is possible, at the moment, only in very special cases. This is also due to its nonlocal behaviour, since for several maps u , the set function $U \mapsto \overline{\mathcal{A}}_{L^1}(u; U)$ is not sub-additive with respect to the open set $U \subseteq \Omega$. This happens, for example, for the symmetric triple junction map u_T on an open disk B_ℓ , as conjectured in [11], and proven in [1]. A complete picture can be found in [6, 22], where $\overline{\mathcal{A}}_{L^1}(u_T; B_\ell)$ is explicitly computed, taking advantage of the symmetry of the map and of B_ℓ . We refer also to [3] where an upper bound inequality is proved for a triple junction map without symmetry assumptions.

Also for the vortex map $u_V : B_\ell \setminus \{0\} \rightarrow \mathbb{S}^1$,

$$u_V(x) := \frac{x}{|x|}, \quad (1.6)$$

the above mentioned nonsubadditivity holds. In [1] it is proved that

$$\overline{\mathcal{A}}_{L^1}(u_V; B_\ell) = \int_{B_\ell} \sqrt{1 + |\nabla u_V|^2} dx + \pi \quad \text{if } \ell \text{ is sufficiently large,} \quad (1.7)$$

while

$$\overline{\mathcal{A}}_{L^1}(u_V; B_\ell) < \int_{B_\ell} \sqrt{1 + |\nabla u_V|^2} dx + \pi \quad \text{if } \ell \text{ is sufficiently small.} \quad (1.8)$$

The explicit computation of $\overline{\mathcal{A}}_{L^1}(u_V; B_\ell)$ for small values of ℓ has been done in [4], again strongly exploiting the symmetries, where it is shown that $\overline{\mathcal{A}}_{L^1}(u_V; B_\ell)$ is related to a Plateau-type problem in codimension 1, whose solution is a sort of (half) catenoid constrained to contain a segment. This ‘‘catenoid’’ describes the vertical part of a Cartesian current [13, 14] obtained as a limit of the graphs of a recovery sequence. Specifically, the main result in [4] reads as

$$\overline{\mathcal{A}}_{L^1}(u_V; B_\ell) = \int_{B_\ell} \sqrt{1 + |\nabla u_V|^2} dx + \inf \mathcal{F}_\varphi(h, \psi), \quad (1.9)$$

¹For scalar valued maps it is known that the domain of $\overline{\mathcal{A}}_{L^1}(\cdot; \Omega)$ is $BV(\Omega)$, and on $BV(\Omega)$ the relaxed functional can be represented as the right-hand side of (1.5), see [10, 15].

where the infimum is taken over all functions $h \in C^0([0, 2\ell]; [-1, 1])$ with $h(0) = h(2\ell) = 1$, and $\psi \in BV((0, 2\ell) \times (-1, 1))$ with $\psi = 0$ on UG_h , and

$$\begin{aligned} \mathcal{F}_\varphi(h, \psi) &= \int_{(0, 2\ell) \times (-1, 1)} \sqrt{1 + |\nabla\psi|^2} \, dt ds + |D\psi|((0, 2\ell) \times (-1, 1)) \\ &\quad + \int_{((0, 2\ell) \times \{-1, 1\}) \cup \{0, 2\ell\} \times [-1, 1]} |\psi - \varphi| d\mathcal{H}^1 - |UG_h|, \end{aligned} \quad (1.10)$$

where $\varphi : \mathbb{R} \times [-1, 1] \rightarrow \mathbb{R}$ is $\varphi(t, s) = \sqrt{1 - s^2}$, and UG_h is the region in $[0, 2\ell] \times [-1, 1]$ upon the graph of h . The latter functional accounts for a Plateau problem in non-parametric form with partial free boundary on a plane domain (see also [5] for more details). If ℓ is large enough, a minimizer of \mathcal{F}_φ has the shape of two half-disks of radius 1, whose total area is π , recovering the result in (1.7).

The L^1 -topology is rather weak, and so it is convenient in order to show compactness results, in the effort of proving existence of minimizers of some possible weak formulation of the two-codimensional Cartesian Plateau problem. However, the above discussion illustrates the difficulties of the study of the corresponding relaxation problem. Besides all nonlocality phenomena, the L^1 convergence does not provide any control on the derivatives of v and, of course, neither on the Jacobian determinant. The aim of the present paper is to study the relaxation of the area in $S = BV(\Omega; \mathbb{R}^2)$ in a different topology, stronger than the L^1 -topology, in order to possibly avoid nonlocality and keep some control of the gradient terms. Specifically, we will take as τ in (1.4) the topology induced by the strict convergence in $BV(\Omega; \mathbb{R}^2)$. This notion of convergence, weaker than the strong $W^{1,1}$ topology, and in general not related with the weak $W^{1,1}$ topology (see Rem. 2.3), allows to consider relaxation in (1.4) for all BV -maps. We recall that (v_k) converges to u strictly $BV(\Omega; \mathbb{R}^2)$ if $v_k \rightarrow u$ in $L^1(\Omega; \mathbb{R}^2)$ and $|Dv_k|(\Omega) \rightarrow |Du|(\Omega)$ (see Sect. 2.1 for details). We are therefore led to consider, for all $u \in BV(\Omega; \mathbb{R}^2)$, the corresponding relaxed area functional $\bar{\mathcal{A}}_\tau = \bar{\mathcal{A}}_{BV}$,

$$\bar{\mathcal{A}}_{BV}(u; \Omega) := \inf \left\{ \liminf_{k \rightarrow +\infty} \mathcal{A}(v_k; \Omega) : (v_k) \subset C^1(\Omega; \mathbb{R}^2) \cap BV(\Omega; \mathbb{R}^2), v_k \rightarrow u \text{ strictly } BV(\Omega; \mathbb{R}^2) \right\}. \quad (1.11)$$

In the first part of the paper we restrict our analysis to maps $w : B_\ell \setminus \{0\} \rightarrow \mathbb{S}^1 = \{x \in \mathbb{R}^2 : |x| = 1\}$ of the form

$$w(x) = \varphi(u_V(x)) = \varphi\left(\frac{x}{|x|}\right), \quad (1.12)$$

with $\varphi : \mathbb{S}^1 \rightarrow \mathbb{S}^1$ Lipschitz continuous. The vortex map corresponds to the case $\varphi = \text{id}$.

After setting some notation and preliminaries in Section 2, in particular the total variation of the Jacobian, the Jacobian distributional determinant $\text{Det}\nabla u$ (Sect. 2.2), and the degree (Sect. 2.3), in Section 3 we prove the following result:

Theorem 1.1. *Let $\ell > 0$, and $w : B_\ell \setminus \{0\} \rightarrow \mathbb{S}^1$ be as in (1.12). Then*

$$\bar{\mathcal{A}}_{BV}(w; B_\ell) = \int_{B_\ell} \sqrt{1 + |\nabla w|^2} dx + \pi |\text{deg}(\varphi)|. \quad (1.13)$$

In particular,

$$\bar{\mathcal{A}}_{BV}(u_V; B_\ell) = \int_{B_\ell} \sqrt{1 + |\nabla u_V|^2} dx + \pi. \quad (1.14)$$

By (1.7), for ℓ large enough we find $\bar{\mathcal{A}}_{BV}(u_V; B_\ell) = \bar{\mathcal{A}}_{L^1}(u_V; B_\ell)$ while by (1.8), for small values of ℓ we have $\bar{\mathcal{A}}_{BV}(u_V; B_\ell) > \bar{\mathcal{A}}_{L^1}(u_V; B_\ell)$. We also remark that for any radius ℓ , in the computation of $\bar{\mathcal{A}}_{BV}(u_V; B_\ell)$, the

minimal surface employed to fill the holes of the graph $\mathcal{G}_{u_V} \subset \mathbb{R}^4$ of u_V is a two dimensional disc living upon the origin of \mathbb{R}^2 .

In Section 4 we extend our analysis to a more general class of maps $u \in W^{1,1}(\Omega; \mathbb{S}^1)$. To state our result, we recall that when $|\text{Det}\nabla u|(\Omega) < +\infty$, then $\text{Det}\nabla u$ can be written as

$$\text{Det}\nabla u = \pi \sum_{i=1}^m d_i \delta_{x_i},$$

where the points $x_i \in \Omega$ are the topological singularities of u , around which the degree of u is nontrivial and equals $d_i \in \mathbb{Z} \setminus \{0\}$ (see Thm. 2.12). We then prove the following:

Theorem 1.2. *Let $u \in W^{1,1}(\Omega; \mathbb{S}^1)$. Suppose that $\text{Det}\nabla u$ is a Radon measure with finite total variation $|\text{Det}\nabla u|(\Omega)$. Then*

$$\bar{\mathcal{A}}_{BV}(u; \Omega) = \int_{\Omega} \sqrt{1 + |\nabla u|^2} dx + |\text{Det}\nabla u|(\Omega) = \int_{\Omega} \sqrt{1 + |\nabla u|^2} dx + \pi \sum_{i=1}^N |d_i|, \quad (1.15)$$

where $N \in \mathbb{N}$ and $d_1, \dots, d_N \in \mathbb{Z} \setminus \{0\}$ are such that $\text{Det}\nabla u = \pi \sum_{i=1}^N d_i \delta_{x_i}$.

The total variation of $\text{Det}\nabla u$ can be characterized by relaxation. More precisely, for maps $v \in W_{\text{loc}}^{1,2}(\Omega; \mathbb{R}^2)$, we introduce the functional $TVJ(v; \Omega) := \int_{\Omega} |\det \nabla v| dx$, measuring the total variation of the Jacobian of v , and consider

$$TVJ_{W^{1,1}}(u; \Omega) := \inf \left\{ \liminf_{k \rightarrow +\infty} TVJ(v_k; \Omega) : (v_k) \subset C^1(\Omega; \mathbb{R}^2) \cap W^{1,1}(\Omega; \mathbb{R}^2), v_k \rightarrow u \text{ in } W^{1,1}(\Omega; \mathbb{R}^2) \right\},$$

for all $u \in W^{1,1}(\Omega; \mathbb{R}^2)$. It is known (see Thm. 2.12) that for u as in Theorem 1.2,

$$TVJ_{W^{1,1}}(u; \Omega) = |\text{Det}\nabla u|(\Omega).$$

In Theorem 4.3 we show that

$$TVJ_{W^{1,1}}(u; \Omega) = TVJ_{BV}(u; \Omega),$$

where

$$TVJ_{BV}(u; \Omega) := \inf \left\{ \liminf_{k \rightarrow +\infty} TVJ(v_k; \Omega) : (v_k) \subset C^1(\Omega; \mathbb{R}^2) \cap BV(\Omega; \mathbb{R}^2), v_k \rightarrow u \text{ strictly } BV(\Omega; \mathbb{R}^2) \right\}.$$

Eventually, in Section 5 we consider some piecewise constant maps valued in \mathbb{S}^1 , in particular the symmetric triple junction map (see Sect. 5 for the precise definition). If we call $T_{\alpha\beta\gamma}$ the equilateral triangle with vertices $\alpha, \beta, \gamma \in \mathbb{S}^1$ and $L := |\beta - \alpha|$ its side length, then we have:

Theorem 1.3. *Let $u_T : B_{\ell} := B_{\ell}(0) \rightarrow \{\alpha, \beta, \gamma\}$ be the symmetric triple-point map. Then*

$$\bar{\mathcal{A}}_{BV}(u_T; B_{\ell}) = |B_{\ell}| + L\mathcal{H}^1(J_{u_T}) + |T_{\alpha\beta\gamma}|, \quad (1.16)$$

where $|\cdot|$ is the Lebesgue measure and J_{u_T} is the jump set of u_T .

In particular, in view of the results in [1], [6], we find $\overline{\mathcal{A}}_{BV}(u_T; B_\ell) > \overline{\mathcal{A}}_{L^1}(u_T; B_\ell)$. We will also see that the same argument used to prove Theorem 1.3 provides a proof also for a symmetric n -uple junction map, as expressed in Corollary 5.3.

As opposite to $\overline{\mathcal{A}}_{L^1}(u; \Omega)$, we see that the functional $\overline{\mathcal{A}}_{BV}(u; \Omega)$, at least for the maps u taking values in \mathbb{S}^1 considered here, is local, and admits an integral representation.

We conclude this introduction by pointing out that, at the present stage, we miss the generalization of our results in higher dimension or codimension. On the one hand the strict convergence in BV provides some control on the gradient of u , and consequently, on the distributional determinant. In the case of maps $u : \Omega \subset \mathbb{R}^3 \rightarrow \mathbb{R}^3$, for instance, this notion of convergence might be useful to get some control of the 2×2 -subdeterminants of ∇u , but seems too weak to control the higher order minor. On the other hand, even in the case of maps $u : \Omega \subset \mathbb{R}^3 \rightarrow \mathbb{R}^2$, the strict convergence in BV is not sufficient to show the counterpart of Proposition 2.4 (see Rem. 2.5) which, in our arguments, is crucial to localize the concentrations of $|\det \nabla v_k|$ (where (v_k) is a sequence of smooth maps converging to u).

2. PRELIMINARIES

In this section we collect some preliminaries. For an integer $M \geq 2$, set $\mathbb{S}^{M-1} := \{x \in \mathbb{R}^M : |x| = 1\}$.

Theorem 2.1 (Reshetnyak). *Let $\Omega \subseteq \mathbb{R}^n$ be an open set and μ_h, μ be finite Radon measures valued in \mathbb{R}^M . Suppose that $\mu_h \xrightarrow{*} \mu$ and $|\mu_h|(\Omega) \rightarrow |\mu|(\Omega)$. Then*

$$\lim_{h \rightarrow +\infty} \int_{\Omega} f \left(x, \frac{\mu_h}{|\mu_h|}(x) \right) d|\mu_h|(x) = \int_{\Omega} f \left(x, \frac{\mu}{|\mu|}(x) \right) d|\mu|(x)$$

for any continuous bounded function $f : \Omega \times \mathbb{S}^{M-1} \rightarrow \mathbb{R}$.

Proof. See for instance ([2], Thm. 2.39). □

2.1. Strict BV -convergence

In what follows, $\Omega \subset \mathbb{R}^2$ is a bounded open set. For any $u \in BV(\Omega; \mathbb{R}^2)$, the distributional derivative Du is a Radon measure valued in $\mathbb{R}^{2 \times 2}$. The symbol $|Du|(\Omega)$ stands for the total variation of Du (see [2], Def. 3.4, p. 119 with $|\cdot|$ the Frobenius norm).

Definition 2.2 (Strict convergence). Let $u \in BV(\Omega; \mathbb{R}^2)$ and $(u_k) \subset BV(\Omega; \mathbb{R}^2)$. We say that (u_k) converges to u strictly BV , if

$$u_k \xrightarrow{L^1} u \quad \text{and} \quad |Du_k|(\Omega) \rightarrow |Du|(\Omega).$$

The topology of the strict convergence in BV is metrized by the distance

$$(u, v) \rightarrow \|u - v\|_{L^1(\Omega; \mathbb{R}^2)} + \left| |Du|(\Omega) - |Dv|(\Omega) \right|, \quad u, v \in BV(\Omega; \mathbb{R}^2).$$

Remark 2.3 (Weak convergences and strict convergence). If $u_k \rightarrow u$ strictly $BV(\Omega)$ then $u_k \rightharpoonup u$ w^* - $BV(\Omega)$, where $u_k \rightharpoonup u$ w^* - $BV(\Omega)$ means:

$$u_k \xrightarrow{L^1} u \quad \text{and} \quad \int_{\Omega} \varphi \cdot Du_k \rightarrow \int_{\Omega} \varphi \cdot Du \quad \forall \varphi \in C_c^0(\Omega; \mathbb{R}^2),$$

with \cdot the scalar product in \mathbb{R}^2 . A similar definition holds for vector valued maps. The converse is not true, already in one dimension: consider the sequence $(f_k) \subset W^{1,1}((0, 2\pi))$,

$$f_k(x) := \frac{1}{k} \sin(kx) \quad \forall x \in (0, 2\pi).$$

Then $f_k \rightharpoonup 0$ weakly in $W^{1,1}((0, 2\pi))$, so in particular w^* - BV , but the convergence is not strict in BV , since $\|f'_k\|_{L^1((0, 2\pi))} = 4$ for all $k \in \mathbb{N}$. We underline that on $W^{1,1}(\Omega; \mathbb{R}^2)$ the strict BV convergence is not comparable with the weak convergence: the following slight modification of Example 4, page 42 in [13], provides a sequence converging strictly $BV((0, 1))$ but not weakly in $W^{1,1}((0, 1))$. Consider the sequence $(g_k) \subset L^1((0, 1))$ defined by

$$g_k(x) := 2^k \sum_{i=0}^{k-1} \chi_{[\frac{i}{k}, \frac{i}{k} + \frac{1}{k2^k}]}(x) \quad \forall x \in [0, 1], \quad \forall k \geq 1,$$

where χ_A is the characteristic function of the set A . Then $\|g_k\|_{L^1} = 1$ for every $k \in \mathbb{N}$. Now, let $f_k \in C([0, 1])$ be the primitive of g_k vanishing at 0; then (f_k) converges uniformly to the identity, and $\|f'_k\|_{L^1} = \|g_k\|_{L^1} = 1 = \|\text{id}'\|_{L^1}$ for any $k \in \mathbb{N}$, and so $f_k \rightarrow \text{id}$ strictly $BV((0, 1))$. On the other hand, (f'_k) cannot converge weakly in L^1 since it is not equi-integrable (see [13], Thm. 2, p. 50): g_k tends to concentrate a large mass in arbitrarily small sets, as k becomes large.

However, the following result (needed in the proof of Props. 3.3 and 4.4) shows that the strict BV convergence implies the uniform one, under certain hypotheses.

Proposition 2.4 (Strict convergence in one dimension). *Let $I = (a, b) \subset \mathbb{R}$ be a bounded interval and let (f_k) be a sequence in $W^{1,1}(I)$. Suppose that (f_k) converges strictly $BV(I)$ to $f \in W^{1,1}(I)$. Then $f_k \rightarrow f$ uniformly in I .*

Proof. First of all, for any open interval $J \subset I$ we have

$$\lim_{k \rightarrow +\infty} \int_J |f'_k| dx = \int_J |f'| dx. \quad (2.1)$$

Indeed, since $f_k \rightharpoonup f$ w^* - $BV(I)$, by the lower semicontinuity of the variation, one has

$$\int_J |f'| dx \leq \liminf_{k \rightarrow +\infty} \int_J |f'_k| dx.$$

On the other hand, using the strict BV convergence on I and again the lower semicontinuity of the variation, we get

$$\begin{aligned} \int_J |f'| dx &= \int_{\bar{J}} |f'| dx = \int_I |f'| dx - \int_{I \setminus \bar{J}} |f'| dx \geq \lim_{k \rightarrow +\infty} \int_I |f'_k| dx - \liminf_{k \rightarrow +\infty} \int_{I \setminus \bar{J}} |f'_k| dx \\ &= \limsup_{k \rightarrow +\infty} \left(\int_I |f'_k| dx - \int_{I \setminus \bar{J}} |f'_k| dx \right) = \limsup_{k \rightarrow +\infty} \int_J |f'_k| dx, \end{aligned}$$

so (2.1) holds.

Now, since f and f_k belong to $W^{1,1}(I)$, we may assume that they are continuous. By contradiction, suppose that (f_k) does not converge uniformly to f , so that, up to a not relabeled subsequence, we may suppose:

$$\exists \delta > 0 \quad \exists (x_k) \subset I \quad \exists k_0 \in \mathbb{N} : \quad |f_k(x_k) - f(x_k)| > \delta \quad \forall k \geq k_0, \quad (2.2)$$

and that there exists $\bar{x} \in \bar{I}$ such that $x_k \rightarrow \bar{x}$. Now consider an open interval $E \subset \bar{I}$ such that $\bar{x} \in E$ and

$$\int_E |f'| dx < \frac{\delta}{4} \quad (2.3)$$

(in case $\bar{x} = a$ or $\bar{x} = b$, E is a semi-open interval). Using (2.1), we can find an index $k_1 \in \mathbb{N}$ such that $k_1 \geq k_0$ and

$$\int_E |f'_k| dx < \frac{\delta}{2} \quad \forall k \geq k_1. \quad (2.4)$$

Moreover, there exists $k_2 \in \mathbb{N}$, $k_2 \geq k_1$, such that $x_k \in E$ for every $k \geq k_2$. Pick a point $y \in E$; then for every $k \geq k_2$, using (2.2), (2.3), and (2.4), we have

$$\begin{aligned} |f_k(y) - f(y)| &\geq -|f_k(y) - f_k(x_k)| + |f_k(x_k) - f(x_k)| - |f(x_k) - f(y)| \\ &\geq -\int_{x_k}^y |f'_k| dx + \delta - \int_{x_k}^y |f'| dx \geq -\int_E |f'_k| dx + \delta - \int_E |f'| dx \\ &\geq -\frac{\delta}{2} + \delta - \frac{\delta}{4} = \frac{\delta}{4}. \end{aligned}$$

Hence, (f_k) (and any subsequence of it) does not converge to f pointwise at every point of E which leads to a contradiction, since $|E| > 0$ and $f_k \xrightarrow{L^1(E)} f$. \square

Remark 2.5. Proposition 2.4 is still valid with the same proof when f_k and f are vector valued. On the contrary, it is crucial that the domain is one-dimensional, since counterexamples can be done already in dimension 2: for instance, the sequence (f_k) given by $f_k(x) := \max\{(1 - k|x|), 0\}$, $x \in \mathbb{R}^2$, converges to 0 in $W^{1,1}(\mathbb{R}^2)$ but not uniformly in any neighborhood of the origin.

2.2. The Jacobian determinant and its total variation

Definition 2.6 (Total variation of the Jacobian). Let $u \in W_{\text{loc}}^{1,2}(\Omega; \mathbb{R}^2)$. We define the total variation of the Jacobian of u as

$$TVJ(u; \Omega) = \int_{\Omega} |\det \nabla u| dx. \quad (2.5)$$

We need to define $TVJ(\cdot; \Omega)$ for other Sobolev maps, in particular for maps with singularities, the main example being the vortex map u_V in (1.6). This can be accomplished in two ways. The first one is to define the distributional Jacobian determinant $\text{Det} \nabla u$: if² $p \in [1, 2)$ and $u \in W^{1,p}(\Omega; \mathbb{R}^2) \cap L_{\text{loc}}^{\infty}(\Omega; \mathbb{R}^2)$,

$$\langle \text{Det} \nabla u, \varphi \rangle := -\frac{1}{2} \int_{\Omega} \text{adj} \nabla u(x) u(x) \cdot \nabla \varphi(x) dx \quad \forall \varphi \in C_c^{\infty}(\Omega), \quad (2.6)$$

where $\text{adj} \nabla u := \begin{pmatrix} \frac{\partial u_2}{\partial y} & -\frac{\partial u_1}{\partial y} \\ -\frac{\partial u_2}{\partial x} & \frac{\partial u_1}{\partial x} \end{pmatrix}$. This definition is justified by the property

$$u \in C^2(\Omega; \mathbb{R}^2) \Rightarrow \det \nabla u = \frac{1}{2} \text{div}(\text{adj} \nabla u u).$$

²If $p = 2$ then $u \in W^{1,2}(\Omega; \mathbb{R}^2)$.

Notice that, if $u \in C^2(\Omega; \mathbb{R}^2)$ and $B_r(x) \subset\subset \Omega$, then by the divergence theorem, writing the outward unit normal to $\partial B_r(x)$ as $\nu = (\nu_1, \nu_2)$, and its $\pi/2$ -counterclockwise rotation $\nu^\perp = \tau = (\tau_1, \tau_2)$,

$$\begin{aligned}
\int_{B_r(x)} \det \nabla u \, dz &= \frac{1}{2} \int_{\partial B_r(x)} (\operatorname{adj} \nabla u) \cdot \nu \, d\mathcal{H}^1 \\
&= \frac{1}{2} \int_{\partial B_r(x)} \left(\left(\frac{\partial u_2}{\partial y} u_1 - \frac{\partial u_1}{\partial y} u_2 \right) \nu_1 + \left(-\frac{\partial u_2}{\partial x} u_1 + \frac{\partial u_1}{\partial x} u_2 \right) \nu_2 \right) d\mathcal{H}^1 \\
&= \frac{1}{2} \int_{\partial B_r(x)} \left(u_1 \left(\frac{\partial u_2}{\partial y}, -\frac{\partial u_2}{\partial x} \right) \cdot \nu + u_2 \left(-\frac{\partial u_1}{\partial y}, \frac{\partial u_1}{\partial x} \right) \cdot \nu \right) d\mathcal{H}^1 \\
&= \frac{1}{2} \int_{\partial B_r(x)} (u_1 \nabla u_2 \cdot \tau - u_2 \nabla u_1 \cdot \tau) d\mathcal{H}^1 \\
&= \frac{1}{2} \int_{\partial B_r(x)} \left(u_1 \frac{\partial u_2}{\partial s} - u_2 \frac{\partial u_1}{\partial s} \right) ds,
\end{aligned} \tag{2.7}$$

where s is the arc-length parameter on ∂B_r .

By Formula (3.7) of [18] (which in turn is a consequence of Theorem 3.2 in [18]), one sees that formula (2.7) is valid also for $u \in W^{1,\infty}(\Omega; \mathbb{R}^2)$.

We recall that

$$\operatorname{Det} \nabla u = \det \nabla u \quad \forall u \in W^{1,2}(\Omega; \mathbb{R}^2),$$

while if $p \in [1, 2)$ they can differ, for instance $\det \nabla u_V$ is null, whereas $\operatorname{Det} \nabla u_V = \pi \delta_0$ (see [20]). Then one is led to define $TVJ(u; \Omega) = |\operatorname{Det} \nabla u|(\Omega)$, for those u for which $\operatorname{Det} \nabla u$ is a Radon measure with finite total variation in Ω .

The second way is to argue by relaxation. For $p \in [1, 2]$ and $u \in W^{1,p}(\Omega; \mathbb{R}^2)$ one sets

$$TVJ_{W^{1,p}}(u; \Omega) := \inf \left\{ \liminf_{k \rightarrow +\infty} TVJ(v_k; \Omega) : (v_k) \subset C^1(\Omega; \mathbb{R}^2) \cap W^{1,p}(\Omega; \mathbb{R}^2), v_k \rightarrow u \text{ in } W^{1,p} \right\}. \tag{2.8}$$

It is known that $TVJ(u; \Omega) = TVJ_{W^{1,2}}(u; \Omega)$ for $u \in W^{1,2}(\Omega; \mathbb{R}^2)$. Moreover, when $p \in [1, 2)$, $TVJ_{W^{1,p}}(u; \Omega)$ coincides with the total variation of the Jacobian distributional determinant of u , provided $u \in W^{1,p}(\Omega; \mathbb{S}^1)$ (see Thm. 2.12 below, and [9], Thm. 11 and Rem. 12). The same conclusions do not hold in general, for maps in $W^{1,p}(\Omega; \mathbb{R}^2)$ which do not take values in \mathbb{S}^1 (see [9], Open problem 5). Notice also that relaxation in (2.8) can also be done with respect to the weak convergence in $W^{1,p}$ (we do not treat this in the present paper and refer the reader to [9, 12, 20]).

We emphasize that we required C^1 -regularity for the approximating sequences in (2.8). This ensures that such sequences are contained in $W_{\operatorname{loc}}^{1,2}(\Omega; \mathbb{R}^2)$ which is the minimal feature to guarantee that $\det \nabla v_k \in L_{\operatorname{loc}}^1(\Omega)$. Replacing the C^1 -regularity with the $W_{\operatorname{loc}}^{1,2}$ -regularity³ gives rise to the same relaxed functionals; this can be seen by a density argument, since any $v \in W_{\operatorname{loc}}^{1,2}(\Omega; \mathbb{R}^2)$ can be approximated by maps $v_k \in C^1(\Omega; \mathbb{R}^2)$ in $W_{\operatorname{loc}}^{1,2}(\Omega; \mathbb{R}^2)$ (such a convergence ensures the corresponding convergence of $TVJ(v_k; \Omega)$ to $TVJ(v; \Omega)$). In the same way, one can also replace the C^1 -regularity with the C^∞ -regularity.

One can also relax TVJ with respect to the strict BV convergence: this will be the content of Theorem 4.3. Moreover, the relaxation with respect to the L^1 convergence is possible, but not interesting for us, because we will deal with maps with values in \mathbb{S}^1 , so the resulting relaxed functional turns out to be zero (see [9], Cor. 5).

³As sometimes can be found in literature.

2.3. Multiplicity and degree

In what follows $B_r(x)$ denotes the open ball of \mathbb{R}^2 centered at x of radius $r > 0$.

Definition 2.7 (Multiplicity). Given $u \in W^{1,1}(\Omega; \mathbb{R}^2)$, for all measurable sets $A \subseteq \Omega$ and all $y \in \mathbb{R}^2$, we set

$$\text{mult}(u, A, y) := \#\{u^{-1}(y) \cap A \cap \mathcal{R}_u\},$$

where $\mathcal{R}_u \subseteq \Omega$ is the set of regular points of u (see [13], p. 202). Similarly, if $u \in W^{1,1}(\partial B_r(x); \mathbb{S}^1)$, we define

$$\text{mult}(u, A, y) := \#\{u^{-1}(y) \cap A \cap \mathcal{R}_u\},$$

for all measurable sets $A \subseteq \partial B_r(x)$ and all $y \in \mathbb{S}^1$.

Let $u \in W^{1,1}(\Omega; \mathbb{R}^2)$; by Theorem 1–6, Section 3.1.5 of [13], if $\det \nabla u \in L^1(\Omega)$, we have

$$\int_A |\det \nabla u| dx = \int_{\mathbb{R}^2} \text{mult}(u, A, y) dy, \quad (2.9)$$

for any measurable set $A \subseteq \Omega$. In particular, $\text{mult}(u, A, \cdot)$ is measurable and finite a.e. in \mathbb{R}^2 .

If a Lipschitz continuous map $\varphi : \partial B_r(x) \rightarrow \mathbb{S}^1$ has constant multiplicity on $\partial B_r(x)$, then we will make use of the simplified notation

$$\text{mult}(\varphi) := \text{mult}(\varphi, \partial B_r(x), \cdot).$$

Definition 2.8 (Degree). Given $u \in W^{1,1}(\Omega; \mathbb{R}^2)$ with $\det \nabla u \in L^1(\Omega)$, for all measurable sets $A \subseteq \Omega$, we let

$$\text{deg}(u, A, y) := \sum_{x \in u^{-1}(y) \cap A \cap \mathcal{R}_u} \text{sign}(\det \nabla u(x)), \quad (2.10)$$

for those $y \in \mathbb{R}^2$ for which $\text{mult}(u, A, \cdot)$ is finite.

Clearly

$$\text{mult}(u, A, \cdot) \geq |\text{deg}(u, A, \cdot)|. \quad (2.11)$$

By Theorems 1–6, Section 3.1.5 of [13], if $\det \nabla u \in L^1(\Omega)$, then

$$\int_A \det \nabla u \, dx = \int_{\mathbb{R}^2} \text{deg}(u, A, y) dy, \quad (2.12)$$

for any measurable set $A \subseteq \Omega$, and by (2.9) and (2.11)

$$\int_{\Omega} |\det \nabla u| dx \geq \int_{\mathbb{R}^2} |\text{deg}(u, \Omega, y)| dy. \quad (2.13)$$

Remark 2.9. The notion (2.10) of degree is too weak to be related to the trace of u on $\partial\Omega$. However, homological invariance is recovered under stronger hypotheses on u ; for instance if u, v are Lipschitz in $\widehat{\Omega} \supset \supset \Omega$ and $u = v$ in $\widehat{\Omega} \setminus \overline{\Omega}$, then $\text{deg}(u, \Omega, \cdot) = \text{deg}(v, \Omega, \cdot)$ a.e. in \mathbb{R}^2 (see [13], p. 233 and 469). In particular, if $u, v : B_r(x) \rightarrow \mathbb{R}^2$ are Lipschitz continuous and $u = v$ on $\partial B_r(x)$, then we might extend u to a Lipschitz map \bar{u} on \mathbb{R}^2 ; the map \bar{v} coinciding with v in $B_r(x)$ and with \bar{u} outside $B_r(x)$ is a Lipschitz extension of v . Hence $\text{deg}(\bar{u}, B_r(x), \cdot) = \text{deg}(\bar{v}, B_r(x), \cdot)$, which implies $\text{deg}(u, B_r(x), \cdot) = \text{deg}(v, B_r(x), \cdot)$.

Definition 2.10. For an open disc $B_r(x) \subset \mathbb{R}^2$ and $u \in W^{1,1}(\partial B_r(x); \mathbb{S}^1)$, we define

$$\deg(u) := \frac{1}{2\pi} \int_{\partial B_r(x)} \left(u_1 \frac{\partial u_2}{\partial s} - u_2 \frac{\partial u_1}{\partial s} \right) ds \in \mathbb{Z}. \quad (2.14)$$

If $u \in W^{1,1}(\Omega; \mathbb{S}^1)$, $B_r(x) \subset\subset \Omega$, and $u \llcorner \partial B_r(x) \in W^{1,1}(\partial B_r(x); \mathbb{S}^1)$ (which is true for almost every r), we set

$$\deg(u, \partial B_r(x)) := \deg(u \llcorner \partial B_r(x)). \quad (2.15)$$

Remark 2.11. If $u : B_r(x) \rightarrow \mathbb{R}^2$ is Lipschitz continuous and $|u| = 1$ on $\partial B_r(x)$, then $\deg(u, B_r(x), \cdot)$ is constant in $B_1 = B_1(0)$, and coincides with $\deg(u, \partial B_r(x))$. Indeed $\deg(u, B_r(x), \cdot)$ is a constant c in B_1 thanks to Theorem 1.3 of [16] (and zero on $\mathbb{R}^2 \setminus B_1$), and then it is sufficient to check that $\deg(u, B_r(x), y) = \deg(u, \partial B_r(x))$, for a.e. $y \in B_1$. By applying (2.7) to the left-hand side of (2.12) one has

$$\int_{\mathbb{R}^2} \deg(u, B_r(x), y) dy = \int_{B_1} \deg(u, B_r(x), y) dy = \pi c = \int_{B_r(x)} \det \nabla u dx = \pi \deg(u \llcorner \partial B_r(x)).$$

In this particular case, thanks to (2.13), we conclude

$$\int_{B_r(x)} |\det \nabla u| dx \geq \int_{B_1} |\deg(u, \partial B_r(x))| dy = \pi |\deg(u, \partial B_r(x))|. \quad (2.16)$$

2.4. Singular Sobolev maps with values in \mathbb{S}^1

We will make use of the following theorems.

Theorem 2.12. *Let $u \in W^{1,1}(\Omega; \mathbb{S}^1)$. Then*

$$TVJ_{W^{1,1}}(u; \Omega) < +\infty \iff \text{Det} \nabla u \text{ is a Radon measure.}$$

In this case $TVJ_{W^{1,1}}(u; \Omega) = |\text{Det} \nabla u|(\Omega)$, and there exists a finite set $\{x_1, \dots, x_m\}$ of points in Ω such that

$$\text{Det} \nabla u = \pi \sum_{i=1}^m d_i \delta_{x_i}, \quad (2.17)$$

where $d_i = \deg(u, \partial B_{r_i}(x_i)) \in \mathbb{Z} \setminus \{0\}$ for a.e. $r_i > 0$ small enough. In particular

$$|\text{Det} \nabla u|(\Omega) = \pi \sum_{i=1}^m |d_i|.$$

Proof. See for instance ([9], Thm. 11) and ([17], Prop. 5.2). □

Remark 2.13. Theorem 2.12 provides the existence of a radius $r_i > 0$ such that the number d_i not only is the degree of the trace of u on $\partial B_{r_i}(x_i)$, but also on almost every circumference $\partial B_\rho(x_i)$ with $\rho < r_i$. Moreover, on these circumferences, we may assume that u is continuous, since its trace is still of class $W^{1,1}$. For more details, we refer the reader to [9].

Theorem 2.14. *Let $u \in W^{1,1}(\mathbb{S}^1; \mathbb{S}^1)$. Then there exists a sequence in $C^\infty(\mathbb{S}^1; \mathbb{S}^1)$ converging to u in $W^{1,1}(\mathbb{S}^1; \mathbb{S}^1)$.*

Proof. See Theorem 2.1 of [19]. □

Theorem 2.15. *Let $B \subset \mathbb{R}^2$ be a bounded open connected set, and $u \in W^{1,1}(B; \mathbb{S}^1)$. Then there exists a sequence in $C^\infty(B; \mathbb{S}^1)$ converging to u in $W^{1,1}(B; \mathbb{S}^1)$ if and only if $\text{Det} \nabla u = 0$ in the sense of distributions.*

Proof. See Theorem 1.5 of [21]. □

3. RELAXATION FOR VORTEX-TYPE MAPS IN $W^{1,p}(B_\ell; \mathbb{S}^1)$: THEOREM 1.1

In this section we focus on maps $w \in W^{1,1}(B_\ell; \mathbb{S}^1)$ of the form (1.12), where $\varphi: \mathbb{S}^1 \rightarrow \mathbb{S}^1$ is a Lipschitz map.

Of course $\det \nabla w = 0$ a.e. on B_ℓ . Moreover, $w \in W^{1,p}(B_\ell; \mathbb{S}^1)$ for every $p \in [1, 2)$; indeed, for $x \in B_\ell \setminus \{0\}$, let us write in polar coordinates

$$w(x) = \tilde{w}(\rho, \theta) = \varphi(\cos \theta, \sin \theta) =: f(\theta) = (f_1(\theta), f_2(\theta)) \quad \forall \rho \in (0, \ell), \quad \forall \theta \in [0, 2\pi). \quad (3.1)$$

Then for a.e. $\theta \in [0, 2\pi)$ and all $\rho \in (0, \ell)$

$$\nabla_{\rho, \theta} \tilde{w}(\rho, \theta) = \begin{pmatrix} 0 & f'_1(\theta) \\ 0 & f'_2(\theta) \end{pmatrix}, \quad |\nabla_{\rho, \theta} \tilde{w}(\rho, \theta)| = |\partial_\theta \tilde{w}(\rho, \theta)| = |f'(\theta)|,$$

$$\begin{aligned} \int_{B_\ell} |\nabla w|^p dx &= \int_0^{2\pi} \int_0^\ell \rho \left(|\partial_\rho \tilde{w}|^2 + \frac{|\partial_\theta \tilde{w}|^2}{\rho^2} \right)^{\frac{p}{2}} d\rho d\theta \\ &= \int_0^{2\pi} \int_0^\ell \frac{|f'(\theta)|^p}{\rho^{p-1}} d\rho d\theta \leq 2\pi \text{lip}(f)^p \int_0^\ell \frac{1}{\rho^{p-1}} d\rho < +\infty; \end{aligned} \quad (3.2)$$

in particular

$$\int_{B_\ell} |\nabla w| dx = \ell \int_0^{2\pi} |f'(\theta)| d\theta. \quad (3.3)$$

Remark 3.1. We have used that f in (3.1) is Lipschitz continuous in $[0, 2\pi)$. Let us check that $\text{lip}(f) = \text{lip}(\varphi)$ and, moreover, $\text{Var}(f) := \int_0^{2\pi} |f'(\theta)| d\theta = \int_{\mathbb{S}^1} |\nabla^{\mathbb{S}^1} \varphi(y)| d\mathcal{H}^1(y) = \text{Var}(\varphi)$, where

$$\nabla^{\mathbb{S}^1} \varphi(z) := \lim_{\substack{y \rightarrow z \\ y \in \mathbb{S}^1 \setminus \{z\}}} \frac{\varphi(y) - \varphi(z)}{|y - z|}, \quad (3.4)$$

is the (tangential) derivative of φ on \mathbb{S}^1 , that is well-defined for a.e. $z \in \mathbb{S}^1$ as an element of the tangent space $T_{\varphi(z)} \mathbb{S}^1$ to \mathbb{S}^1 at $\varphi(z)$. Fix $y_0 \in \mathbb{S}^1$ where φ is differentiable, and take the unique $\theta_0 \in [0, 2\pi)$ such that $y_0 = (\cos \theta_0, \sin \theta_0)$. From (3.4), it follows

$$\nabla^{\mathbb{S}^1} \varphi(y_0) = \frac{d}{d\theta}|_{\theta=\theta_0} \varphi(\cos \theta, \sin \theta) = f'(\theta_0), \quad (3.5)$$

and therefore $\text{lip}(\varphi) = \text{lip}(f)$. Moreover

$$\text{Var}(\varphi) = \int_{\mathbb{S}^1} |\nabla^{\mathbb{S}^1} \varphi(y)| d\mathcal{H}^1(y) = \int_0^{2\pi} |f'(\theta)| d\theta = \text{Var}(f). \quad (3.6)$$

In particular, from (3.3), we conclude

$$\int_{B_\ell} |\nabla w| \, dx = \ell \text{Var}(\varphi). \quad (3.7)$$

Remark 3.2 (Lifting). A lifting of φ is a map $\bar{\Phi} : [0, 2\pi] \rightarrow \mathbb{R}$ such that

$$\varphi(\cos \theta, \sin \theta) = (\cos(\bar{\Phi}(\theta)), \sin(\bar{\Phi}(\theta))) \quad \forall \theta \in [0, 2\pi]. \quad (3.8)$$

The function $f(\cdot) = \varphi(\cos(\cdot), \sin(\cdot)) : [0, 2\pi] \rightarrow \mathbb{S}^1$ being continuous on a simply-connected set, always admits a continuous lifting $\bar{\Phi} : [0, 2\pi] \rightarrow \mathbb{R}$ such that

$$\varphi(\cos \theta, \sin \theta) = f(\theta) = (\cos(\bar{\Phi}(\theta)), \sin(\bar{\Phi}(\theta))).$$

Moreover, since the covering map $t \in \mathbb{R} \mapsto e^{it} \in \mathbb{S}^1$ satisfies $|e^{it_1} - e^{it_2}| \leq |t_1 - t_2| \leq \pi |e^{it_1} - e^{it_2}|$ for all t_1, t_2 with $|t_1 - t_2| \leq \pi$, any continuous lifting of φ must be Lipschitz, indeed

$$\frac{|\bar{\Phi}(\theta_1) - \bar{\Phi}(\theta_2)|}{|\theta_1 - \theta_2|} \leq \pi \frac{|e^{i\bar{\Phi}(\theta_1)} - e^{i\bar{\Phi}(\theta_2)}|}{|e^{i\theta_1} - e^{i\theta_2}|} = \pi \frac{|\varphi(e^{i\theta_1}) - \varphi(e^{i\theta_2})|}{|e^{i\theta_1} - e^{i\theta_2}|} \quad \forall \theta_1, \theta_2 \in [0, 2\pi] \text{ with } |\theta_1 - \theta_2| \leq \pi; \quad (3.9)$$

while if $|\theta_1 - \theta_2| > \pi$, the left-hand side is bounded by $\frac{2}{\pi} \max_{[0, 2\pi]} |\bar{\Phi}|$.

Using the 2π -periodicity of f , we see that $\bar{\Phi}(2\pi) - \bar{\Phi}(0) \in 2\pi\mathbb{Z}$; hence $\bar{\Phi}$ can be extended in a Lipschitz way to the whole of \mathbb{R} (this can be done extending periodically its first derivative). It is possible to see that the lifting is unique up to a multiple of 2π : fix a starting point, e.g. $(1, 0) \in \mathbb{S}^1$ and set $\varphi(1, 0) =: y_0 \in \mathbb{S}^1$. Now extract the Argument $\theta(y_0) \in [0, 2\pi)$ of y_0 , and define $\Phi : \mathbb{R} \rightarrow \mathbb{R}$ as

$$\Phi(t) := \theta(y_0) + \int_0^t \lambda_\varphi(s) \, ds, \quad (3.10)$$

where $\lambda_\varphi(s) \in \mathbb{R}$ is uniquely determined by

$$\nabla^{\mathbb{S}^1} \varphi(\cos s, \sin s) = \lambda_\varphi(s) \tau_{\varphi(\cos s, \sin s)} \quad \text{a.e. } s \in \mathbb{R}, \quad (3.11)$$

with

$$\tau_{\varphi(\cos s, \sin s)} = \varphi^\perp(\cos s, \sin s) = (-\varphi_2(\cos s, \sin s), \varphi_1(\cos s, \sin s)) \quad (3.12)$$

the unit tangent vector to \mathbb{S}^1 (counter-clockwise oriented) at the point $\varphi(\cos s, \sin s)$. By definition, Φ is Lipschitz in \mathbb{R} since $\text{lip}(\Phi) = \|\lambda_\varphi\|_\infty = \text{lip}(\varphi)$. In order to show the lifting property (3.8), take a lifting $\bar{\Phi} : \mathbb{R} \rightarrow \mathbb{R}$ of φ . Differentiating the equality $\varphi(\cos s, \sin s) = (\cos(\bar{\Phi}(s)), \sin(\bar{\Phi}(s)))$ gives

$$\lambda_\varphi(s) \tau_{\varphi(\cos s, \sin s)} = \bar{\Phi}'(s) (-\sin(\bar{\Phi}(s)), \cos(\bar{\Phi}(s))) = \bar{\Phi}'(s) \tau_{\varphi(\cos s, \sin s)}, \quad \text{a.e. } s \in \mathbb{R},$$

so that $\bar{\Phi}' = \lambda_\varphi$ a.e. in \mathbb{R} . This implies, by (3.10), that $\Phi(t) - \bar{\Phi}(t)$ is a constant multiple of 2π . Thus Φ also satisfies (3.8), and any lifting of φ is of the form (3.10), up to a constant multiple of 2π .

As a further consequence of the previous discussion and of (3.11)–(3.12), for any lifting $\tilde{\Phi}$ of φ , and in particular for Φ , the map $\tilde{f}(\theta) = (\cos(\tilde{\Phi}(\theta)), \sin(\tilde{\Phi}(\theta)))$ satisfies the same linear ordinary differential system as

f , namely

$$f'_1 = -\Phi' f_2, \quad f'_2 = \Phi' f_1 \quad \text{a.e. in } \mathbb{R}. \quad (3.13)$$

Finally, from (3.13) it follows $\lambda_\varphi = f_1 f'_2 - f_2 f'_1$ a.e. in \mathbb{R} , so that by (2.14), we get

$$\Phi(2\pi) = \Phi(0) + \int_0^{2\pi} \lambda_\varphi(\theta) d\theta = \Phi(0) + 2\pi \deg(\varphi). \quad (3.14)$$

Now we can start the proof of Theorem 1.1: As usual, we divide it into two parts, the lower bound (Prop. 3.3) and the upper bound (Prop. 3.4).

Proposition 3.3 (Lower bound). *Let $w : B_\ell \setminus \{0\} \rightarrow \mathbb{S}^1$ be the map defined in (1.12). Suppose that $(v_k) \subset C^1(B_\ell; \mathbb{R}^2) \cap BV(B_\ell; \mathbb{R}^2)$ is such that $v_k \rightarrow w$ strictly $BV(B_\ell; \mathbb{R}^2)$. Then*

$$\liminf_{k \rightarrow +\infty} \mathcal{A}(v_k; B_\ell) \geq \int_{B_\ell} \sqrt{1 + |\nabla w|^2} dx + \pi |\deg(\varphi)|.$$

Proof. We may assume that

$$\liminf_{k \rightarrow +\infty} \mathcal{A}(v_k; B_\ell) = \lim_{k \rightarrow +\infty} \mathcal{A}(v_k; B_\ell) < +\infty.$$

We define the functions $\psi_k, \psi : (0, \ell) \rightarrow [0, +\infty)$ as

$$\psi_k(r) := \int_{\partial B_r} |\nabla v_k| ds, \quad \psi(r) := \liminf_{k \rightarrow +\infty} \psi_k(r), \quad r \in (0, \ell),$$

where s is an arc length parameter on ∂B_r . By Fubini's theorem it follows

$$\int_0^\ell \psi_k(r) dr = \int_{B_\ell} |\nabla v_k| dx,$$

hence, using Fatou's lemma, the strict convergence of (v_k) to w , and (3.7),

$$\begin{aligned} \int_0^\ell \psi(r) dr &\leq \liminf_{k \rightarrow +\infty} \int_0^\ell \psi_k(r) dr = \lim_{k \rightarrow +\infty} \int_{B_\ell} |\nabla v_k| dx \\ &= \int_{B_\ell} |\nabla w| dx = \ell \text{Var}(\varphi). \end{aligned} \quad (3.15)$$

In particular,

$$\psi \text{ is almost everywhere finite in } (0, \ell).$$

Now we claim that

$$\psi = \text{Var}(\varphi) \quad \text{a.e. in } (0, \ell). \quad (3.16)$$

Indeed, without loss of generality we may assume that (v_k) converges to w almost everywhere in B_ℓ , so that for almost every $r \in (0, \ell)$

$$v_k \llcorner \partial B_r \rightarrow w \llcorner \partial B_r \quad \mathcal{H}^1 - \text{a.e. in } \partial B_r. \quad (3.17)$$

Now fix $r \in (0, \ell)$ such that (3.17) holds; consider the total variation of $v_k \llcorner \partial B_r$, that is the $L^1(\partial B_r)$ -norm of the tangential derivative of v_k (as in (3.4)):

$$|D(v_k \llcorner \partial B_r)|(\partial B_r) = \int_{\partial B_r} \left| \frac{\partial v_k}{\partial s} \right| ds.$$

Clearly

$$\liminf_{k \rightarrow +\infty} \int_{\partial B_r} \left| \frac{\partial v_k}{\partial s} \right| ds \leq \liminf_{k \rightarrow +\infty} \int_{\partial B_r} |\nabla v_k| ds = \psi(r). \quad (3.18)$$

Let us extract a subsequence $(v_{k_h}) \subset (v_k)$ depending on r , such that

$$\liminf_{k \rightarrow +\infty} \int_{\partial B_r} \left| \frac{\partial v_k}{\partial s} \right| ds = \lim_{h \rightarrow +\infty} \int_{\partial B_r} \left| \frac{\partial v_{k_h}}{\partial s} \right| ds. \quad (3.19)$$

Since ψ is almost everywhere finite, we may suppose that $\psi(r) < +\infty$, so that the sequence $(v_{k_h} \llcorner \partial B_r)$ is bounded in $BV(\partial B_r; \mathbb{R}^2)$. Thus, using (3.17), we also have

$$v_{k_h} \llcorner \partial B_r \rightharpoonup w \llcorner \partial B_r \quad \text{weakly}^* \text{ in } BV(\partial B_r; \mathbb{R}^2) \quad \text{as } h \rightarrow +\infty. \quad (3.20)$$

Now, since ∇w is only tangential, and $|\nabla w(r, \theta)|^2 = \frac{|f'(\theta)|^2}{r^2}$, we get

$$\int_{\partial B_r} \left| \frac{\partial w}{\partial s} \right| ds = \int_{\partial B_r} |\nabla w| ds = \int_0^{2\pi} r |f'(\theta)| \frac{1}{r} d\theta = \text{Var}(\varphi). \quad (3.21)$$

Hence, using the lower semicontinuity of the variation along $(v_{k_h} \llcorner \partial B_r)$, (3.19), and (3.18) we infer

$$\begin{aligned} \text{Var}(\varphi) &= \int_{\partial B_r} \left| \frac{\partial w}{\partial s} \right| ds \leq \liminf_{h \rightarrow +\infty} \int_{\partial B_r} \left| \frac{\partial v_{k_h}}{\partial s} \right| ds \\ &= \lim_{h \rightarrow +\infty} \int_{\partial B_r} \left| \frac{\partial v_{k_h}}{\partial s} \right| ds = \liminf_{k \rightarrow +\infty} \int_{\partial B_r} \left| \frac{\partial v_k}{\partial s} \right| ds \leq \psi(r). \end{aligned} \quad (3.22)$$

Thus $\psi \geq \text{Var}(\varphi)$ almost everywhere in $(0, \ell)$ and, from (3.15), we deduce $\psi = \text{Var}(\varphi)$ almost everywhere in $(0, \ell)$, and so (3.16) is proved.

As a consequence of the previous arguments,

$$\begin{aligned} \forall \varepsilon \in (0, \ell) \quad \exists r_\varepsilon \in (0, \varepsilon) \quad \exists (v_{k_h}) \subset (v_k) \quad \text{s.t.} \\ v_{k_h} \llcorner \partial B_{r_\varepsilon} \rightarrow w \llcorner \partial B_{r_\varepsilon} \quad \text{strictly } BV(\partial B_{r_\varepsilon}; \mathbb{R}^2), \end{aligned} \quad (3.23)$$

where the subsequence (v_{k_h}) depends on ε . Indeed, proving (3.16), we have shown that for almost every $r \in (0, \ell)$, there exists a subsequence (v_{k_h}) satisfying (3.20); so, given $\varepsilon \in (0, \ell)$, there exists $r_\varepsilon \in (0, \varepsilon)$ and a subsequence

(v_{k_h}) depending on ε , such that

$$v_{k_h} \llcorner \partial B_{r_\varepsilon} \rightharpoonup w \llcorner \partial B_{r_\varepsilon} \quad \text{weakly}^* \text{ in } BV(\partial B_{r_\varepsilon}; \mathbb{R}^2). \quad (3.24)$$

But from the previous discussion we also deduce

$$\lim_{h \rightarrow +\infty} \int_{\partial B_{r_\varepsilon}} \left| \frac{\partial v_{k_h}}{\partial s} \right| ds = \psi(r_\varepsilon) = \text{Var}(\varphi) = \int_{\partial B_{r_\varepsilon}} \left| \frac{\partial w}{\partial s} \right| ds; \quad (3.25)$$

thus the convergence in (3.24) is actually strict in $BV(\partial B_{r_\varepsilon}; \mathbb{R}^2)$.

Now, fix $\varepsilon \in (0, \ell)$ and, for simplicity, denote by (v_h) the subsequence (v_{k_h}) for which (3.23) holds. Remember that our approximating maps $v_h = ((v_h)_1, (v_h)_2)$ are of class $C^1(\Omega; \mathbb{R}^2)$, so they might have non-zero Jacobian determinant $Jv_h := \det \nabla v_h$, as opposed to $w = (w_1, w_2)$, whose Jacobian determinant vanishes a.e. in B_ℓ . In particular, we expect the contribution of area given by Jv_h to be non trivial around the origin. Thus, we split the area functional as follows:

$$\mathcal{A}(v_h; B_\ell) = \mathcal{A}(v_h; B_\ell \setminus B_{r_\varepsilon}) + \mathcal{A}(v_h; B_{r_\varepsilon}) \geq \mathcal{A}(v_h; B_\ell \setminus B_{r_\varepsilon}) + \int_{B_{r_\varepsilon}} |Jv_h| dx,$$

and notice that, by definition of relaxed functional and Theorem 3.7 of [1],

$$\liminf_{h \rightarrow +\infty} \mathcal{A}(v_h; B_\ell \setminus B_{r_\varepsilon}) \geq \overline{\mathcal{A}}_{L^1}(u; B_\ell \setminus B_{r_\varepsilon}) \geq \int_{B_\ell \setminus B_{r_\varepsilon}} \sqrt{1 + |\nabla w|^2} dx.$$

Hence

$$\begin{aligned} \lim_{h \rightarrow +\infty} \mathcal{A}(v_h; B_\ell) &\geq \liminf_{h \rightarrow +\infty} \mathcal{A}(v_h; B_\ell \setminus B_{r_\varepsilon}) + \liminf_{h \rightarrow +\infty} \int_{B_{r_\varepsilon}} |Jv_h| dx \\ &\geq \int_{B_\ell \setminus B_{r_\varepsilon}} \sqrt{1 + |\nabla w|^2} dx + \liminf_{h \rightarrow +\infty} \int_{B_{r_\varepsilon}} |Jv_h| dx. \end{aligned} \quad (3.26)$$

To conclude the proof it is then sufficient to show that

$$\liminf_{h \rightarrow +\infty} \int_{B_{r_\varepsilon}} |Jv_h| dx \geq \pi |\deg(\varphi)|. \quad (3.27)$$

Define the sequence $w_h : B_\ell \rightarrow \mathbb{R}^2$ as

$$w_h(x) := \begin{cases} v_h(x) & \text{if } |x| \leq r_\varepsilon \\ \frac{\ell - |x|}{\ell - r_\varepsilon} v_h\left(\frac{r_\varepsilon x}{|x|}\right) + \frac{|x| - r_\varepsilon}{\ell - r_\varepsilon} w\left(\frac{r_\varepsilon x}{|x|}\right) & \text{if } r_\varepsilon < |x| < \ell. \end{cases} \quad (3.28)$$

Then w_h is Lipschitz continuous and interpolates $v_h \llcorner \partial B_{r_\varepsilon}$ and $w \llcorner \partial B_{r_\varepsilon}$ in the annulus enclosed by $\partial B_{r_\varepsilon}$ and ∂B_ℓ . Now we show that

$$\lim_{h \rightarrow +\infty} \int_{B_\ell \setminus B_{r_\varepsilon}} |Jw_h| dx = 0. \quad (3.29)$$

Indeed, passing to polar coordinates in $B_\ell \setminus B_{r_\varepsilon}$:

$$w_h(x) = \tilde{w}_h(\rho, \theta) = \frac{\ell - \rho}{\ell - r_\varepsilon} \tilde{v}_h(r_\varepsilon, \theta) + \frac{\rho - r_\varepsilon}{\ell - r_\varepsilon} \tilde{w}(r_\varepsilon, \theta),$$

where

$$\tilde{v}_h(r_\varepsilon, \theta) := v_h(r_\varepsilon(\cos \theta, \sin \theta)) = ((\tilde{v}_h)_1(r_\varepsilon, \theta), (\tilde{v}_h)_2(r_\varepsilon, \theta)), \quad \tilde{w}(r_\varepsilon, \theta) := w(r_\varepsilon(\cos \theta, \sin \theta)) = f(\theta).$$

Making use of (3.1) and (3.13), we get

$$\nabla \tilde{w}_h(\rho, \theta) = \frac{1}{\ell - r_\varepsilon} \begin{pmatrix} -(\tilde{v}_h)_1 + f_1 & (\ell - \rho)\partial_\theta(\tilde{v}_h)_1 - (\rho - r_\varepsilon)\Phi' f_2 \\ -(\tilde{v}_h)_2 + f_2 & (\ell - \rho)\partial_\theta(\tilde{v}_h)_2 + (\rho - r_\varepsilon)\Phi' f_1 \end{pmatrix}, \quad (3.30)$$

where $(\tilde{v}_h)_i$, $\partial_\theta(\tilde{v}_h)_i$ are evaluated at (r_ε, θ) for $i = 1, 2$, and f_1, f_2, Φ' are evaluated at θ . Then we can compute the Jacobian determinant of w_h in polar coordinates:

$$\begin{aligned} J\tilde{w}_h(\rho, \theta) &= \frac{1}{(\ell - r_\varepsilon)^2} \left[(\ell - \rho) \left\{ (\tilde{v}_h)_2 \partial_\theta(\tilde{v}_h)_1 - \partial_\theta(\tilde{v}_h)_1 f_2 \right\} \right. \\ &\quad \left. + (\ell - \rho) \left\{ \partial_\theta(\tilde{v}_h)_2 f_1 - (\tilde{v}_h)_1 \partial_\theta(\tilde{v}_h)_2 \right\} - (\rho - r_\varepsilon) \Phi' \left\{ (\tilde{v}_h)_1 f_1 + (\tilde{v}_h)_2 f_2 - 1 \right\} \right], \end{aligned}$$

where we use also that $f_1^2 + f_2^2 = 1$. Thus

$$\begin{aligned} \int_{B_\ell \setminus B_{r_\varepsilon}} |Jw_h| dx &= \int_{r_\varepsilon}^\ell \int_0^{2\pi} |J\tilde{w}_h| d\rho d\theta \\ &\leq C_{\ell, \varepsilon} \int_{r_\varepsilon}^\ell \int_0^{2\pi} |(\tilde{v}_h)_2 \partial_\theta(\tilde{v}_h)_1 - \partial_\theta(\tilde{v}_h)_1 f_2| d\rho d\theta \\ &\quad + C_{\ell, \varepsilon} \int_{r_\varepsilon}^\ell \int_0^{2\pi} |(\tilde{v}_h)_1 \partial_\theta(\tilde{v}_h)_2 - \partial_\theta(\tilde{v}_h)_2 f_1| d\rho d\theta \\ &\quad + C_{\ell, \varepsilon} \text{lip}(\Phi) \int_{r_\varepsilon}^\ell \int_0^{2\pi} |(\tilde{v}_h)_1 f_1 + (\tilde{v}_h)_2 f_2 - 1| d\rho d\theta, \end{aligned} \quad (3.31)$$

where $C_{\ell, \varepsilon}$ is a positive constant depending only on ℓ and ε . Consider the first integral on the right hand side of (3.31): its integrand is independent of ρ , and so

$$\begin{aligned} \int_{r_\varepsilon}^\ell \int_0^{2\pi} |(\tilde{v}_h)_2 \partial_\theta(\tilde{v}_h)_1 - \partial_\theta(\tilde{v}_h)_1 f_2(\theta)| d\rho d\theta &= (\ell - r_\varepsilon) \int_0^{2\pi} |(\tilde{v}_h)_2(r_\varepsilon, \theta) - f_2(\theta)| |\partial_\theta(\tilde{v}_h)_1(r_\varepsilon, \theta)| d\theta \\ &\leq C_{\ell, \varepsilon} \|(v_h)_2 - w_2\|_{L^\infty(\partial B_{r_\varepsilon})} \int_{\partial B_{r_\varepsilon}} \left| \frac{\partial v_h}{\partial s} \right| ds \xrightarrow{k \rightarrow +\infty} 0, \end{aligned}$$

where in passing to the limit we used (3.23), which implies that the variation of v_h on $\partial B_{r_\varepsilon}$ is necessarily equi-bounded and, together with Proposition 2.4, that $v_h \rightarrow w$ uniformly on $\partial B_{r_\varepsilon}$. For the second integral, the argument is similar.

As for the third one, by the uniform convergence of (v_h) to w on $\partial B_{r_\varepsilon}$, we can pass to the limit under the integral sign:

$$\int_{r_\varepsilon}^\ell \int_0^{2\pi} |(\tilde{v}_h)_1 f_1 + (\tilde{v}_h)_2 f_2 - 1| d\rho d\theta \xrightarrow{h \rightarrow +\infty} \int_{r_\varepsilon}^\ell \int_0^{2\pi} |f_1^2 + f_2^2 - 1| d\rho d\theta = 0.$$

Therefore, (3.29) holds.

Now, we write the Jacobian determinant of v_h on B_{r_ε} in the following way:

$$\int_{B_{r_\varepsilon}} |Jv_h| dx = \int_{B_\ell} |Jw_h| dx - \int_{B_\ell \setminus B_{r_\varepsilon}} |Jw_h| dx. \quad (3.32)$$

Notice that $w_h = w$ on ∂B_ℓ , so that (see Rems. 2.9 and 2.11)

$$\deg(w_h, \partial B_\ell) = \deg(w, \partial B_\ell) = \deg(\varphi). \quad (3.33)$$

We may suppose that v_h takes values in \overline{B}_1 , since the limit function w is valued in \mathbb{S}^1 (see [1], Lem. 3.3). So $w_h : \overline{B}_\ell \rightarrow \overline{B}_1$ is Lipschitz continuous and maps ∂B_ℓ into ∂B_1 . Then, by (3.33) and (2.16), we have

$$\int_{B_\ell} |Jw_h| dx \geq \pi |\deg(w, \partial B_\ell)| = \pi |\deg(\varphi)|. \quad (3.34)$$

Finally, passing to the lower limit as $h \rightarrow +\infty$ in (3.32), using (3.29) and the previous inequality, we deduce estimate (3.27), which concludes the proof. \square

Proposition 3.4 (Upper bound). *Let $w : B_\ell \setminus \{0\} \rightarrow \mathbb{R}^2$ be the map defined in (1.12). Then there exists a sequence $(v_k) \subset C^1(B_\ell; \mathbb{R}^2) \cap BV(B_\ell; \mathbb{R}^2)$ such that $v_k \rightarrow w$ strictly $BV(B_\ell; \mathbb{R}^2)$ and*

$$\limsup_{k \rightarrow +\infty} \mathcal{A}(v_k; B_\ell) \leq \int_{B_\ell} \sqrt{1 + |\nabla w|^2} dx + \pi |\deg(\varphi)|. \quad (3.35)$$

Proof. Although v_k needs to be of class C^1 , we claim that it suffices to build v_k just Lipschitz continuous. Indeed, assume that $(v_k) \subset W^{1,\infty}(B_\ell; \mathbb{R}^2) \cap C^1(B_\ell; \mathbb{R}^2)$ converges to w strictly $BV(B_\ell; \mathbb{R}^2)$ and (3.35) holds. Consider, for all $k \in \mathbb{N}$, a sequence $(v_h^k) \subset C^1(B_\ell; \mathbb{R}^2)$ approaching v_k in $W^{1,2}(B_\ell; \mathbb{R}^2)$ as $h \rightarrow +\infty$. In particular, we get the L^1 -convergence of all minors of ∇v_h^k to the corresponding ones of ∇v_k . Then, by dominated convergence,

$$\lim_{h \rightarrow +\infty} \mathcal{A}(v_h^k; B_\ell) = \mathcal{A}(v_k; B_\ell). \quad (3.36)$$

Hence, by a diagonal argument, we find a sequence $(v_{h_k}^k)$ converging to w strictly $BV(B_\ell; \mathbb{R}^2)$ such that (3.35) holds for $v_{h_k}^k$ in place of v_k .

Let us consider the map $\overline{\varphi} : \mathbb{S}^1 \rightarrow \mathbb{S}^1$ given by

$$\overline{\varphi}(\cos \theta, \sin \theta) := (\cos(d\theta), \sin(d\theta)) \quad \text{where } d := \deg(\varphi). \quad (3.37)$$

Then

$$\text{mult}(\overline{\varphi}) = |\deg(\overline{\varphi})|, \quad \deg(\overline{\varphi}) = \deg(\varphi), \quad (3.38)$$

and, in particular, $\text{mult}(\overline{\varphi}) = |\deg(\varphi)|$. Moreover, since the maps φ and $\overline{\varphi}$ have the same degree, we can construct a Lipschitz homotopy $H : [0, 1] \times \mathbb{S}^1 \rightarrow \mathbb{S}^1$ between them. Precisely, if Φ and $\overline{\Phi}$ are Lipschitz liftings of φ

and $\bar{\varphi}$ respectively, we define $\Psi(t, \cdot) := t\Phi(\cdot) + (1-t)\bar{\Phi}(\cdot)$, which is Lipschitz. Hence one defines the map $H(t, \cdot) : [0, 2\pi) \rightarrow \mathbb{S}^1$ as $H(t, \cdot) := (\cos(\Psi(t, \cdot)), \sin(\Psi(t, \cdot)))$, which satisfies

$$H(0, \cdot) = \bar{\varphi}(\cdot), \quad H(1, \cdot) = \varphi(\cdot). \quad (3.39)$$

It remains to show that $H(t, \cdot)$ defines a continuous (and then Lipschitz) map from \mathbb{S}^1 to \mathbb{S}^1 , *i.e.* that is 2π -periodic: to this aim it is enough to observe that $\Psi(t, 2\pi)$ and $\Psi(t, 0)$ differ from a constant multiple of 2π and indeed, recalling (3.14), we have $\Phi(2\pi) - \Phi(0) = 2\pi d = \bar{\Phi}(2\pi) - \bar{\Phi}(0)$, from which easily follows that $\Psi(t, 2\pi) - \Psi(t, 0) = 2\pi d$.

We now define the sequence $(v_k) \subset \text{Lip}(B_\ell; \mathbb{R}^2)$ as $v_k(0) := 0$,

$$v_k := \begin{cases} \bar{v}_k & \text{in } B_{\frac{\ell}{k}} \setminus \{0\}, \\ h_k & \text{in } B_{\frac{2\ell}{k}} \setminus B_{\frac{\ell}{k}}, \\ w = \varphi\left(\frac{x}{|x|}\right) & \text{in } B_\ell \setminus B_{\frac{2\ell}{k}}, \end{cases} \quad (3.40)$$

where

$$\bar{v}_k(x) := \frac{k}{\ell}|x|\bar{\varphi}\left(\frac{x}{|x|}\right) \quad \forall x \in B_{\frac{\ell}{k}},$$

and

$$h_k(x) := H\left(\frac{k}{\ell}|x| - 1, \frac{x}{|x|}\right) \quad \forall x \in B_{\frac{2\ell}{k}} \setminus B_{\frac{\ell}{k}}.$$

Let us check that

$$\int_{B_\ell} |Jv_k| dx = \pi|d| \quad \forall k \in \mathbb{N}. \quad (3.41)$$

Since H and w take values on \mathbb{S}^1 , we have

$$\int_{B_\ell \setminus B_{\frac{\ell}{k}}} |Jv_k| dx = \int_{B_{\frac{2\ell}{k}} \setminus B_{\frac{\ell}{k}}} |Jh_k| dx + \int_{B_\ell \setminus B_{\frac{2\ell}{k}}} |Jw| dx = 0.$$

Moreover, $\text{mult}(\bar{v}_k, B_{\frac{\ell}{k}}, \cdot) = \text{mult}(\bar{\varphi})$, and therefore, by (2.9),

$$\int_{B_{\frac{\ell}{k}}} |Jv_k| dx = \int_{B_{\frac{\ell}{k}}} |J\bar{v}_k| dx = \int_{B_1} \text{mult}(\bar{v}_k, B_{\frac{\ell}{k}}, y) dy = |B_1| \text{mult}(\bar{\varphi}) = \pi|d|.$$

We now prove that $v_k \rightarrow w$ in $W^{1,p}(B_\ell; \mathbb{R}^2)$ for every $p \in [1, 2)$. This, in particular, implies the desired strict convergence in BV . Since $v_k = w$ in $B_\ell \setminus B_{\frac{2\ell}{k}}$, we have to do the computation in $B_{\frac{2\ell}{k}}$:

$$\int_{B_{\frac{2\ell}{k}}} |v_k - w|^p dx \leq 2^{p-1} \int_{B_{\frac{2\ell}{k}}} (|v_k|^p + |w|^p) dx \leq 2^p |B_{\frac{2\ell}{k}}| \xrightarrow{k \rightarrow +\infty} 0.$$

In addition

$$|\nabla v_k| = |\nabla h_k| \leq 2k \operatorname{lip}(H) \quad \text{a.e. in } B_{\frac{2\ell}{k}} \setminus B_{\frac{\ell}{k}},$$

hence

$$\begin{aligned} \int_{B_{\frac{2\ell}{k}} \setminus B_{\frac{\ell}{k}}} |\nabla v_k - \nabla w|^p dx &\leq C \left[(2k)^p \operatorname{lip}(H)^p |B_{\frac{2\ell}{k}}| + \int_{B_{\frac{2\ell}{k}}} |\nabla w|^p dx \right] \\ &\leq C \left[C \frac{k^p}{k^2} + \int_{B_{\frac{2\ell}{k}}} |\nabla w|^p dx \right] \xrightarrow{k \rightarrow +\infty} 0, \end{aligned} \quad (3.42)$$

where $C > 0$ is a positive constant independent of k . Finally, setting $\bar{w}(x) := \bar{\varphi}\left(\frac{x}{|x|}\right)$ for $x \in B_\ell \setminus \{0\}$, we have

$$\nabla v_k(x) = \frac{k}{\ell} |x| \nabla \bar{w}(x) + \frac{k}{\ell} \bar{w}(x) \otimes \frac{x}{|x|} \quad \text{for a.e. } x \in B_{\frac{\ell}{k}}.$$

Whence

$$\begin{aligned} \int_{B_{\frac{\ell}{k}}} |\nabla v_k - \nabla w|^p dx &\leq C \int_{B_{\frac{\ell}{k}}} \left(k^p |x|^p |\nabla \bar{w}|^p + k^p \left| \bar{w}(x) \otimes \frac{x}{|x|} \right| + |\nabla w|^p \right) dx \\ &\leq C \left[\int_{B_{\frac{\ell}{k}}} |\nabla \bar{w}|^p dx + k^p |B_{\frac{\ell}{k}}| + \int_{B_{\frac{\ell}{k}}} |\nabla w|^p dx \right] \xrightarrow{k \rightarrow +\infty} 0. \end{aligned} \quad (3.43)$$

Now, we easily get (3.35): upon extracting a (not relabelled) subsequence such that (∇v_k) converges almost everywhere to ∇w , by (3.41) and dominated convergence theorem we have

$$\limsup_{k \rightarrow +\infty} \mathcal{A}(v_k; B_\ell) \leq \lim_{k \rightarrow +\infty} \int_{B_\ell} \sqrt{1 + |\nabla v_k|^2} dx + \lim_{k \rightarrow +\infty} \int_{B_\ell} |Jv_k| dx = \int_{B_\ell} \sqrt{1 + |\nabla w|^2} dx + \pi |d|.$$

□

Remark 3.5. In the proof of the upper bound in Proposition 3.4 we have shown the $W^{1,p}$ convergence of the recovery sequence to the function w , for $p \in [1, 2)$. Hence

$$\bar{\mathcal{A}}_{W^{1,p}}(w; B_\ell) \leq \int_{B_\ell} \sqrt{1 + |\nabla w|^2} dx + \pi |\operatorname{deg}(\varphi)|.$$

Moreover, since in general $\bar{\mathcal{A}}_{BV}(\cdot; B_\ell) \leq \bar{\mathcal{A}}_{W^{1,p}}(\cdot; B_\ell)$ for all $p \geq 1$, we deduce

$$\bar{\mathcal{A}}_{W^{1,p}}(w; B_\ell) = \int_{B_\ell} \sqrt{1 + |\nabla w|^2} dx + \pi |\operatorname{deg}(\varphi)|.$$

4. RELAXATION FOR MAPS IN $W^{1,1}(\Omega; \mathbb{S}^1)$: THEOREM 1.2

In the following lemma we generalize to a generic function in $W^{1,1}(B_\ell; \mathbb{S}^1)$ the argument used to prove (3.23), by showing that the strict BV convergence on B_ℓ is inherited to almost every circumference centered at the origin. Unlike (3.23) of Proposition 3.3, in this more general context we have to make use of Theorem 2.1.

We start to generalize the arguments leading to (3.25).

Lemma 4.1 (Inheritance). *Let $(v_k) \subset C^1(B_\ell; \mathbb{R}^2)$, $u \in W^{1,1}(B_\ell; \mathbb{R}^2)$, and suppose that $v_k \rightarrow u$ strictly $BV(B_\ell; \mathbb{R}^2)$. Then, for almost every $r \in (0, \ell)$, there exists a subsequence (v_{k_n}) , depending on r , such that*

$$v_{k_n} \llcorner \partial B_r \rightarrow u \llcorner \partial B_r \quad \text{strictly } BV(\partial B_r; \mathbb{R}^2).$$

Proof. The (tangential) variation of the restriction of u on ∂B_r is well-defined and finite for almost every $r \in (0, \ell)$ since $u \in W^{1,1}(B_\ell; \mathbb{R}^2)$, and

$$|D(u \llcorner \partial B_r)|(\partial B_r) := \int_{\partial B_r} \left| \frac{\partial u}{\partial s} \right| ds = \int_0^{2\pi} |\partial_\theta \tilde{u}(r, \theta)| d\theta,$$

where $\tilde{u} : R := (0, \ell) \times [0, 2\pi) \rightarrow \mathbb{R}^2$, $\tilde{u}(\rho, \theta) := u(\rho \cos \theta, \rho \sin \theta)$. We compute

$$\int_R |\partial_\theta \tilde{u}| d\rho d\theta = \int_{B_\ell} |(\nabla u)\tau| dx, \quad (4.1)$$

with $\tau(x) := \frac{1}{|x|}(-x_2, x_1)$, $x \neq 0$. Indeed

$$\begin{aligned} \int_R |\partial_\theta \tilde{u}| d\rho d\theta &= \int_0^\ell \int_0^{2\pi} \left[\sum_{i=1}^2 \rho^2 ((\partial_{x_1} u_i)^2 (\sin \theta)^2 + (\partial_{x_2} u_i)^2 (\cos \theta)^2 - 2\partial_{x_1} u_i \partial_{x_2} u_i \cos \theta \sin \theta) \right]^{\frac{1}{2}} d\rho d\theta \\ &= \int_{B_\ell} \frac{1}{|x|} \left[\sum_{i=1}^2 ((\partial_{x_1} u_i)^2 x_2^2 + (\partial_{x_2} u_i)^2 x_1^2 - 2\partial_{x_1} u_i \partial_{x_2} u_i x_1 x_2) \right]^{\frac{1}{2}} dx \\ &= \int_{B_\ell} \sqrt{|\nabla u_1 \cdot \tau|^2 + |\nabla u_2 \cdot \tau|^2} dx = \int_{B_\ell} |(\nabla u)\tau| dx. \end{aligned}$$

In the same way we get

$$\int_R |\partial_\theta \tilde{v}_k| d\rho d\theta = \int_{B_\ell} |(\nabla v_k)\tau| dx.$$

Thanks to Theorem 2.1, with the choices $M = 4$, $\mathbb{S}^3 \subset \mathbb{R}^4 = \mathbb{R}^{2 \times 2}$, $f \in C_b((B_\ell \setminus \{0\}) \times \mathbb{S}^3)$,

$$f(x, \sigma) := \sqrt{|\sigma_{\text{hor}} \cdot \tau(x)|^2 + |\sigma_{\text{vert}} \cdot \tau(x)|^2},$$

where $\sigma \in \mathbb{S}^3$ and $\sigma_{\text{hor}} := (\sigma_1, \sigma_2)$, $\sigma_{\text{vert}} := (\sigma_3, \sigma_4)$, we obtain

$$\lim_{k \rightarrow +\infty} \int_{B_\ell} |(\nabla v_k)\tau| dx = \int_{B_\ell} |(\nabla u)\tau| dx. \quad (4.2)$$

Now we notice that for almost every $r \in (0, \ell)$ we have

$$v_k \llcorner \partial B_r \rightarrow u \llcorner \partial B_r \quad \text{in } L^1(\partial B_r; \mathbb{R}^2).$$

Then, since $(v_k \llcorner \partial B_r) \subset BV(\partial B_r; \mathbb{R}^2)$ for every $r \in (0, \ell)$, by the lower semicontinuity of the variation we get

$$\int_{\partial B_r} \left| \frac{\partial u}{\partial s} \right| ds \leq \liminf_{k \rightarrow +\infty} \int_{\partial B_r} \left| \frac{\partial v_k}{\partial s} \right| ds \quad \text{for a.e. } r \in (0, \ell). \quad (4.3)$$

Integrating with respect to r and by Fatou's lemma, we obtain

$$\int_R |\partial_\theta \tilde{u}| dr d\theta = \int_0^\ell \int_{\partial B_r} \left| \frac{\partial u}{\partial s} \right| ds dr \leq \int_0^\ell \liminf_{k \rightarrow +\infty} \int_{\partial B_r} \left| \frac{\partial v_k}{\partial s} \right| ds dr \leq \liminf_{k \rightarrow +\infty} \int_R |\partial_\theta \tilde{v}_k| dr d\theta. \quad (4.4)$$

But we notice that, by (4.1) and (4.2), we must have all equalities in (4.4). In particular,

$$\int_{\partial B_r} \left| \frac{\partial u}{\partial s} \right| ds = \liminf_{k \rightarrow +\infty} \int_{\partial B_r} \left| \frac{\partial v_k}{\partial s} \right| ds \quad \text{for a.e. } r \in (0, \ell),$$

and we conclude extracting a suitable subsequence (v_{k_h}) of (v_k) depending on r such that

$$\lim_{h \rightarrow +\infty} \int_{\partial B_r} \left| \frac{\partial v_{k_h}}{\partial s} \right| ds = \liminf_{k \rightarrow +\infty} \int_{\partial B_r} \left| \frac{\partial v_k}{\partial s} \right| ds.$$

□

Definition 4.2. Let $u \in W^{1,1}(\Omega; \mathbb{S}^1)$ and $TVJ_{W^{1,1}}(u; \Omega) < +\infty$. We set

$$TVJ_{BV}(u; \Omega) := \inf \left\{ \liminf_{k \rightarrow +\infty} TVJ(v_k; \Omega) : (v_k) \subset C^1(\Omega; \mathbb{R}^2) \cap BV(\Omega; \mathbb{R}^2), v_k \rightarrow u \text{ strictly } BV \right\}.$$

The proof of Theorem 1.2 is essentially a consequence of the following theorem.

Theorem 4.3 (Relaxation of TVJ in the strict convergence). Let $u \in W^{1,1}(\Omega; \mathbb{S}^1)$ be such that $TVJ_{W^{1,1}}(u; \Omega) < +\infty$, and write $\text{Det} \nabla u$ as in (2.17). Then

$$TVJ_{BV}(u; \Omega) = \pi \sum_{i=1}^m |d_i|.$$

In particular, $TVJ_{BV}(u; \Omega) = TVJ_{W^{1,1}}(u; \Omega) = |\text{Det} \nabla u|(\Omega)$.

As usual, we divide the proof of Theorem 4.3 into two parts, the lower bound (Prop. 4.4) and the upper bound (Prop. 4.5).

Proposition 4.4 (Lower bound for TVJ_{BV}). Let $u \in W^{1,1}(\Omega; \mathbb{S}^1)$ be such that $TVJ_{W^{1,1}}(u; \Omega) < +\infty$, and write $\text{Det} \nabla u$ as in (2.17). Then

$$TVJ_{BV}(u; \Omega) \geq \pi \sum_{i=1}^m |d_i|.$$

Proof. According to Theorem 2.12, we choose a radius $\ell > 0$ so that the balls $B_\ell(x_i) \subset \Omega$, $i = 1, \dots, m$, are disjoint. Let $(v_k) \subset C^1(\Omega; \mathbb{R}^2)$ be such that $v_k \rightarrow u$ strictly $BV(B_\ell; \mathbb{R}^2)$ and

$$\lim_{k \rightarrow +\infty} \int_\Omega |Jv_k| dx = TVJ_{BV}(u; \Omega).$$

To show the thesis it is sufficient to prove that, for all $i = 1, \dots, m$,

$$\lim_{k \rightarrow +\infty} \int_{B_\ell(x_i)} |Jv_k| dx \geq \pi d_i,$$

and it suffices to show this inequality for $i = 1$. Let us denote $B_\ell(x_1)$ simply by B_ℓ . Without loss of generality we may assume $x_1 = (0, 0)$. Since $u \in W^{1,1}(B_\ell; \mathbb{S}^1)$, it is $W^{1,1}(\partial B_r; \mathbb{S}^1)$, in particular continuous, for almost every $r \in (0, \ell)$. Thus, we can choose $\bar{r} > 0$ small enough so that $u \llcorner \partial B_{\bar{r}} \in W^{1,1}(\partial B_{\bar{r}}; \mathbb{S}^1)$. Since the balls $B_\ell(x_i)$, $i = 1, \dots, m$, are disjoint, we also have $\deg(u, \partial B_{\bar{r}}, \cdot) = d_1$. From Theorem 2.14 and Lemma 4.1, we get that

$$\begin{aligned} \forall \varepsilon \in (0, \bar{r}) \quad \exists r_\varepsilon \in (0, \varepsilon) \quad \exists (v_{k_h}) \subset (v_k) \quad \exists (u_h) \subset C^\infty(\partial B_{r_\varepsilon}; \mathbb{S}^1) \quad \text{s.t.} \\ u \llcorner \partial B_{r_\varepsilon} \in W^{1,1}(\partial B_{r_\varepsilon}; \mathbb{S}^1), \quad u_h \rightarrow u \llcorner \partial B_{r_\varepsilon} \quad \text{in } W^{1,1}(\partial B_{r_\varepsilon}; \mathbb{S}^1), \\ \text{and } v_{k_h} \llcorner \partial B_{r_\varepsilon} \rightarrow u \llcorner \partial B_{r_\varepsilon} \quad \text{strictly } BV(\partial B_{r_\varepsilon}; \mathbb{R}^2). \end{aligned} \quad (4.5)$$

In particular, on $\partial B_{r_\varepsilon}$ we have uniform convergence of (u_h) and (v_{k_h}) to u by Proposition 2.4. Setting as usual $Jv_{k_h} = \det \nabla v_{k_h}$, write

$$\int_{B_{r_\varepsilon}} |Jv_{k_h}| dx = \int_{B_{\bar{r}}} |Jw_h| dx - \int_{B_{\bar{r}} \setminus B_{r_\varepsilon}} |Jw_h| dx,$$

where $w_h \in \text{Lip}(B_{\bar{r}}; \mathbb{R}^2)$ and is given by

$$w_h(x) := \begin{cases} v_{k_h}(x) & \text{if } |x| \leq r_\varepsilon \\ \frac{\bar{r} - |x|}{\bar{r} - r_\varepsilon} v_{k_h} \left(r_\varepsilon \frac{x}{|x|} \right) + \frac{|x| - r_\varepsilon}{\bar{r} - r_\varepsilon} u_h \left(r_\varepsilon \frac{x}{|x|} \right) & \text{if } r_\varepsilon < |x| \leq \bar{r}. \end{cases} \quad (4.6)$$

Now, since $\|v_{k_h} - u_h\|_{L^\infty(\partial B_{r_\varepsilon})} \rightarrow 0$ as $h \rightarrow +\infty$, arguing as in the proof of (3.29) we have

$$\lim_{h \rightarrow +\infty} \int_{B_{\bar{r}} \setminus B_{r_\varepsilon}} |Jw_h| dx = 0. \quad (4.7)$$

Moreover, from (4.6) we note that

$$\deg(w_h, \partial B_{\bar{r}}) = \deg(u_h, \partial B_{r_\varepsilon}). \quad (4.8)$$

Thanks to the uniform convergence of (u_h) to u on $\partial B_{r_\varepsilon}$, for h large enough, u_h and $u \llcorner \partial B_{r_\varepsilon}$ must have the same degree

$$\deg(u_h, \partial B_{r_\varepsilon}) = \deg(u, \partial B_{r_\varepsilon}) = d_1.$$

Then, arguing as in (3.34), we obtain that

$$\int_{B_{\bar{r}}} |Jw_h| dx \geq \pi |\deg(w_h, \partial B_{\bar{r}})| = \pi |d_1|,$$

for $h \in \mathbb{N}$ sufficiently large. In conclusion we get

$$TVJ_{BV}(u; B_\ell) = \lim_{h \rightarrow +\infty} \int_{B_\ell} |Jv_{k_h}| dx \geq \liminf_{h \rightarrow +\infty} \int_{B_{r_\varepsilon}} |Jv_{k_h}| dx \geq \liminf_{h \rightarrow +\infty} \int_{B_{\bar{r}}} |Jw_h| dx \geq \pi |d_1|. \quad (4.9)$$

□

Proposition 4.5 (Upper bound for TVJ_{BV}). *Let $u \in W^{1,1}(\Omega; \mathbb{S}^1)$ be such that $TVJ_{W^{1,1}}(u; \Omega) < +\infty$, and write $\text{Det}\nabla u$ as in (2.17). Then*

$$TVJ_{BV}(u; \Omega) \leq \pi \sum_{i=1}^m |d_i|.$$

Proof. As in the proof of Proposition 4.4 we choose a radius $\ell > 0$ so that the balls $B_\ell(x_i) \subset \Omega$, $i = 1, \dots, m$, are disjoint.

We construct a suitable recovery sequence $(v_k) \subset \text{Lip}(\Omega; \mathbb{R}^2)$ such that

$$\lim_{k \rightarrow +\infty} v_k = u \quad \text{in } W^{1,1}(\Omega; \mathbb{R}^2) \quad (4.10)$$

and setting $B := \cup_{i=1}^m B_\ell(x_i)$,

$$\lim_{k \rightarrow +\infty} \int_{B_\ell(x_i)} |Jv_k| dx = \pi |d_i|, \quad i = 1, \dots, m, \quad \text{and} \quad \int_{\Omega \setminus B} |Jv_k| dx = 0. \quad (4.11)$$

As in the proof of Proposition 4.4, we can find $r_1 \leq \ell$ so that $u \in W^{1,1}(\partial B_{r_1}(x_i); \mathbb{R}^2)$ and $\deg(u, \partial B_{r_1}(x_i)) = d_i$, for all $i = 1, \dots, m$. For every $k \in \mathbb{N}$, we set $B_k := \cup_{i=1}^m B_{2^{-k}r_1}(x_i)$. By Theorem 2.15, there exists a sequence $(u_n^k)_{n \in \mathbb{N}} \subset C^\infty(\Omega \setminus B_k; \mathbb{S}^1)$ such that

$$\lim_{n \rightarrow +\infty} u_n^k = u \quad \text{in } W^{1,1}(\Omega \setminus B_k; \mathbb{S}^1). \quad (4.12)$$

Now, for all $k > 1$, we choose $r_k \in (2^{-k}r_1, 2^{-k+1}r_1)$ such that the following conditions hold: for all $i = 1, \dots, m$,

$$\begin{aligned} u \llcorner \partial B_{r_k}(x_i) &\in W^{1,1}(\partial B_{r_k}(x_i); \mathbb{S}^1), \\ \lim_{n \rightarrow +\infty} \|u_n^k \llcorner \partial B_{r_k}(x_i) - u \llcorner \partial B_{r_k}(x_i)\|_{W^{1,1}(\partial B_{r_k}(x_i); \mathbb{S}^1)} &= 0. \end{aligned} \quad (4.13)$$

In particular, for all $k > 1$ and $i = 1, \dots, m$, we have

$$\lim_{n \rightarrow +\infty} \|u_n^k \llcorner \partial B_{r_k}(x_i) - u \llcorner \partial B_{r_k}(x_i)\|_{L^\infty(\partial B_{r_k}(x_i); \mathbb{S}^1)} = 0, \quad (4.14)$$

thus, using (2.15), (4.13) and (2.14), we obtain

$$\begin{aligned} &|\deg(u_n^k, \partial B_{r_k}(x_i)) - \deg(u, \partial B_{r_k}(x_i))| \\ &\leq \frac{1}{2\pi} \left(\int_{\partial B_{r_k}(x_i)} \left| (u_n^k)_1 \frac{\partial (u_n^k)_2}{\partial s} - u_1 \frac{\partial u_2}{\partial s} \right| ds + \int_{\partial B_{r_k}(x_i)} \left| (u_n^k)_2 \frac{\partial (u_n^k)_1}{\partial s} - u_2 \frac{\partial u_1}{\partial s} \right| ds \right) \rightarrow 0 \end{aligned} \quad (4.15)$$

as $n \rightarrow +\infty$.

Therefore, there exists $m_k \in \mathbb{N}$ such that, for all $i = 1, \dots, m$,

$$\deg(u_n^k, \partial B_{r_k}(x_i)) = \deg(u, \partial B_{r_k}(x_i)) = d_i \quad \forall n \geq m_k. \quad (4.16)$$

Now, using (4.12) and (4.13), for all $k > 1$ there is $\tilde{m}_k \in \mathbb{N}$ such that, for all $i = 1, \dots, m$,

$$\|u_n^k - u\|_{W^{1,1}(\Omega \setminus (\cup_{i=1}^m B_{r_k}(x_i)); \mathbb{S}^1)} \leq \|u_n^k - u\|_{W^{1,1}(\Omega \setminus B_k; \mathbb{S}^1)} \leq \frac{1}{k} \quad \forall n \geq \tilde{m}_k, \quad (4.17)$$

$$\|u_n^k \llcorner \partial B_{r_k}(x_i) - u \llcorner \partial B_{r_k}(x_i)\|_{W^{1,1}(\partial B_{r_k}(x_i); \mathbb{S}^1)} \leq \frac{1}{k} \quad \forall n \geq \tilde{m}_k. \quad (4.18)$$

Setting $n_k := \max\{m_k, \tilde{m}_k\}$, we define $u_k := u_{n_k}^k$, which satisfies (4.16) and (4.17) for all $k > 1$. In particular

$$\lim_{k \rightarrow +\infty} \|u_k - u\|_{W^{1,1}(\Omega \setminus (\cup_{i=1}^m B_{r_k}(x_i)); \mathbb{S}^1)} = 0. \quad (4.19)$$

For all $i = 1, \dots, m$, let now $\bar{\varphi}_i : \mathbb{S}^1 \rightarrow \mathbb{S}^1$ be the Lipschitz function defined in (3.37) with $d = d_i$, which satisfies

$$\text{mult}(\bar{\varphi}_i) = |\text{deg}(\bar{\varphi}_i)| \quad \text{and} \quad \text{deg}(\bar{\varphi}_i) = d_i.$$

Now, for all $i = 1, \dots, m$, $\bar{\varphi}_i$ and $u_k \llcorner \partial B_{r_k}(x_i)$ have the same degree, and so there exists a Lipschitz homotopy⁴ $H_{k,i} : [0, 1] \times \mathbb{S}^1 \rightarrow \mathbb{S}^1$ such that

$$H_{k,i}(0, y) = \bar{\varphi}_i(y), \quad H_{k,i}(1, y) = u_k(r_k y + x_i), \quad y \in \mathbb{S}^1.$$

Let us define the sequence $(v_k) \subset \text{Lip}(\Omega; \mathbb{R}^2)$ as follows: $v_k := u_k$ in $\Omega \setminus B$, and, for all $i = 1, \dots, m$, $v_k(x_i) := 0$ and

$$v_k(x) := \begin{cases} \frac{|x - x_i|}{r_{k+1}} \bar{\varphi}_i\left(\frac{x - x_i}{|x - x_i|}\right) & \text{if } x \in B_{r_{k+1}}(x_i) \setminus \{0\}, \\ h_{k,i}(x) & \text{if } x \in B_{r_k}(x_i) \setminus B_{r_{k+1}}(x_i), \\ u_k(x) & \text{if } x \in B_\ell(x_i) \setminus B_{r_k}(x_i), \end{cases} \quad (4.20)$$

where

$$h_{k,i}(x) := H_{k,i}\left(\frac{|x - x_i| - r_{k+1}}{r_k - r_{k+1}}, \frac{x - x_i}{|x - x_i|}\right) \quad \forall x \in B_{r_k}(x_i) \setminus B_{r_{k+1}}(x_i).$$

Since $H_{k,i}$ and u_k take values in \mathbb{S}^1 , we have $v_k(x) \in \mathbb{S}^1$ for $x \in \Omega \setminus (\cup_{i=1}^m B_{r_{k+1}}(x_i))$, and so

$$\int_{\Omega \setminus (\cup_{i=1}^m B_{r_{k+1}}(x_i))} |Jv_k| dx = 0.$$

In particular, the second condition in (4.11) holds. Moreover, $\text{mult}(v_k, B_{r_{k+1}}(x_i), \cdot) = \text{mult}(\bar{\varphi}_i)$, and therefore, by (2.9),

$$\int_{B_{r_{k+1}}(x_i)} |Jv_k| dx = \int_{B_1} \text{mult}(v_k, B_{r_{k+1}}(x_i), y) dy = |B_1| \text{mult}(\bar{\varphi}_i) = \pi |d_i|,$$

and also the first condition in (4.11) follows.

It remains to show (4.10). By (4.19) and (4.17) we have

$$\begin{aligned} \int_{\Omega} |v_k - u| dx &\leq \int_{\Omega \setminus (\cup_{i=1}^m B_{r_k}(x_i))} |u_k - u| dx + 2m |B_{r_k}(0)| \rightarrow 0 \quad \text{as } k \rightarrow +\infty, \\ \int_{\Omega \setminus (\cup_{i=1}^m B_{r_k}(x_i))} |\nabla v_k - \nabla u| dx &= \int_{\Omega \setminus (\cup_{i=1}^m B_{r_k}(x_i))} |\nabla u_k - \nabla u| dx \rightarrow 0 \quad \text{as } k \rightarrow +\infty. \end{aligned}$$

⁴To define it it suffices to consider two liftings of $\bar{\varphi}_1$ and $u_k(r_k \cdot + x_1) \llcorner \mathbb{S}^1$, and linearly interpolate them, as done for H in (3.39). Observe that $H_{k,i}$ is Lipschitz since $u_k \llcorner \partial B_{r_k}(x_i)$ is Lipschitz by the choice of r_k .

Now, let us show that, for all $i = 1, \dots, m$,

$$\lim_{k \rightarrow +\infty} \|\nabla h_{k,i}\|_{L^1(B_{r_k(x_i)} \setminus B_{r_{k+1}}(x_i))} = 0.$$

Let us make the computation for $i = 1$, the other cases being identical. Set $H_k = H_{k,1}$ and $h_k = h_{k,1}$. Assume without loss of generality that $x_1 = (0, 0)$, and denote $B_r(x_1) = B_r$. By definition of H_k we have

$$\|\partial_t H_k\|_{L^\infty([0,1] \times \mathbb{S}^1)} \leq \|\bar{\varphi}_1\|_{L^\infty(\mathbb{S}^1)} + \|u_k\|_{L^\infty(\partial B_{r_k})} \leq 2 \quad \forall k \in \mathbb{N}. \quad (4.21)$$

Moreover, since $\bar{\varphi}_1$ is Lipschitz,

$$|\nabla_y H_k(t, y)| \leq |\nabla^{\mathbb{S}^1} \bar{\varphi}_1(y)| + r_k |\nabla u_k(r_k y)| \leq C + r_k |\nabla u_k(r_k y)|. \quad (4.22)$$

We now compute ∇h_k for $x \in B_{r_k} \setminus B_{r_{k+1}}$:

$$\nabla h_k(x) = \frac{1}{r_k - r_{k+1}} \partial_t H_k \left(\frac{|x| - r_{k+1}}{r_k - r_{k+1}}, \frac{x}{|x|} \right) \otimes \frac{x}{|x|} + \nabla_y H_k \left(\frac{|x| - r_{k+1}}{r_k - r_{k+1}}, \frac{x}{|x|} \right) \nabla \left(\frac{x}{|x|} \right)$$

and we get

$$\begin{aligned} & \int_{B_{r_k} \setminus B_{r_{k+1}}} |\nabla h_k| dx \\ & \leq \int_{B_{r_k} \setminus B_{r_{k+1}}} \frac{1}{r_k - r_{k+1}} \left| \partial_t H_k \left(\frac{|x| - r_{k+1}}{r_k - r_{k+1}}, \frac{x}{|x|} \right) \right| + \left| \nabla_y H_k \left(\frac{|x| - r_{k+1}}{r_k - r_{k+1}}, \frac{x}{|x|} \right) \right| \left| \nabla \left(\frac{x}{|x|} \right) \right| dx \\ & \leq \frac{1}{r_k - r_{k+1}} \|\partial_t H_k\|_{L^\infty} |B_{r_k} \setminus B_{r_{k+1}}| + \int_{r_{k+1}}^{r_k} \int_0^{2\pi} \rho \frac{1}{\rho} \left| \nabla_y H_k \left(\frac{\rho - r_{k+1}}{r_k - r_{k+1}}, (\cos \theta, \sin \theta) \right) \right| d\rho d\theta \\ & \leq C(r_k + r_{k+1}) + C(r_k - r_{k+1}) + (r_k - r_{k+1}) \int_0^{2\pi} r_k |\nabla u_k(r_k(\cos \theta, \sin \theta))| d\theta \\ & \leq C r_k + (r_k - r_{k+1}) \int_{\partial B_{r_k}} |\nabla u_k| d\mathcal{H}^1 \leq C(r_k + (r_k - r_{k+1})) \rightarrow 0 \quad \text{as } k \rightarrow +\infty, \end{aligned} \quad (4.23)$$

where we have used (4.18) in the last inequality. Then we conclude

$$\int_{B_{r_k} \setminus B_{r_{k+1}}} |\nabla v_k - \nabla u| dx = \int_{B_{r_k} \setminus B_{r_{k+1}}} |\nabla h_k - \nabla u| dx \leq \int_{B_{r_k} \setminus B_{r_{k+1}}} |\nabla h_k| dx + \int_{B_{r_k} \setminus B_{r_{k+1}}} |\nabla u| dx \rightarrow 0.$$

Finally, for $x \in B_{r_{k+1}}$, we have

$$\nabla v_k(x) = \frac{1}{r_{k+1}} \frac{x}{|x|} \otimes \bar{\varphi}_1 \left(\frac{x}{|x|} \right) + \frac{1}{r_{k+1}} |x| \nabla \left(\bar{\varphi}_1 \left(\frac{x}{|x|} \right) \right).$$

Then, since $\bar{\varphi}_1$ is Lipschitz,

$$|\nabla v_k(x)| \leq \frac{C}{r_{k+1}},$$

so we get

$$\int_{B_{r_{k+1}}} |\nabla v_k - \nabla u| dx \leq \frac{C}{r_{k+1}} |B_{r_{k+1}}| + \int_{B_{r_{k+1}}} |\nabla u| dx \rightarrow 0,$$

and (4.10) follows. \square

Now, we can prove Theorem 1.2.

Proof. We start with the proof of the lower bound. Arguing as in the proof of Proposition 4.4, we may suppose $m = 1$, $\Omega = B_\ell$ and $x_1 = (0, 0)$. Let $(v_k) \subset C^1(B_\ell; \mathbb{R}^2)$ be such that $v_k \rightarrow u$ strictly $BV(B_\ell; \mathbb{R}^2)$ and

$$\liminf_{k \rightarrow +\infty} \mathcal{A}(v_k; B_\ell) = \lim_{k \rightarrow +\infty} \mathcal{A}(v_k; B_\ell) < +\infty.$$

Select $r_1 > 0$ and $d_1 \in \mathbb{Z}$ as in the proof of Proposition 4.5. Without loss of generality we can suppose that $r_1 = \ell$. So we deduce (4.5) and the uniform convergence of (v_k) to u on almost every circumference in B_ℓ . Now write $\mathcal{A}(v_k; B_\ell) = \mathcal{A}(v_k; B_\ell \setminus B_{r_\varepsilon}) + \mathcal{A}(v_k; B_{r_\varepsilon}) \geq \mathcal{A}(v_k; B_\ell \setminus B_{r_\varepsilon}) + \int_{B_{r_\varepsilon}} |Jv_k| dx$, so that

$$\begin{aligned} \lim_{k \rightarrow +\infty} \mathcal{A}(v_k; B_\ell) &\geq \liminf_{k \rightarrow +\infty} \mathcal{A}(v_k; B_\ell \setminus B_{r_\varepsilon}) + \liminf_{k \rightarrow +\infty} \int_{B_{r_\varepsilon}} |Jv_k| dx \\ &\geq \int_{B_\ell \setminus B_{r_\varepsilon}} \sqrt{1 + |\nabla u|^2} dx + \liminf_{k \rightarrow +\infty} \int_{B_{r_\varepsilon}} |Jv_k| dx. \end{aligned} \quad (4.24)$$

We now apply (4.9) and next pass to the limit as $\varepsilon \rightarrow 0^+$ to get the lower bound in (1.15), *i.e.*,

$$\liminf_{k \rightarrow +\infty} \mathcal{A}(v_k; B_\ell) \geq \int_{\Omega} \sqrt{1 + |\nabla u|^2} dx + \pi \sum_{i=1}^N |d_i|.$$

Concerning the proof of the upper bound, consider the sequence (v_k) defined in (4.20), which converges to u in $W^{1,1}(\Omega; \mathbb{R}^2)$. Then, upon extracting a subsequence such that (∇v_k) converges almost everywhere to ∇u , by (4.11) and dominated convergence we have, using the inequality $\sqrt{1 + a^2 + b^2 + c^2} \leq \sqrt{1 + a^2 + b^2} + |c|$ for $a, b, c \in \mathbb{R}$,

$$\begin{aligned} \limsup_{k \rightarrow +\infty} \mathcal{A}(v_k; B_\ell(x_i)) &\leq \lim_{k \rightarrow +\infty} \int_{B_\ell(x_i)} \sqrt{1 + |\nabla v_k|^2} dx + \lim_{k \rightarrow +\infty} \int_{B_\ell(x_i)} |Jv_k| dx \\ &= \int_{B_\ell(x_i)} \sqrt{1 + |\nabla u|^2} dx + \pi |d_i|, \end{aligned}$$

that leads to

$$\begin{aligned} \limsup_{k \rightarrow +\infty} \mathcal{A}(v_k; \Omega) &\leq \lim_{k \rightarrow +\infty} \int_{\Omega \setminus \cup_{i=1}^m B_\ell(x_i)} \sqrt{1 + |\nabla v_k|^2} dx + \limsup_{k \rightarrow +\infty} \mathcal{A}(v_k; \cup_{i=1}^m B_\ell(x_i)) \\ &= \int_{\Omega} \sqrt{1 + |\nabla u|^2} dx + \pi \sum_{i=1}^m |d_i|. \end{aligned}$$

\square

Remark 4.6. If $u \in W^{1,p}(\Omega; \mathbb{S}^1)$, $p \in [1, 2)$, the recovery sequence defined in (4.20) converges to u in $W^{1,p}(\Omega; \mathbb{S}^1)$ as well. Then, the results of Theorems 4.3 and 1.2 are still valid if one deals with the relaxation of the area functional with respect to the strong topology of $W^{1,p}(\Omega; \mathbb{S}^1)$.

Remark 4.7 (Relaxation in the local uniform convergence outside singularities). If u is continuous in $\Omega \setminus \{x_1, \dots, x_m\}$, one can relax the area functional with respect to the uniform convergence out of the singularities $\{x_i\}$, *i.e.*, we require that for every compact set $K \subset \Omega \setminus \{x_1, \dots, x_m\}$ the approximating sequence $(u_k) \subset C^1(\Omega; \mathbb{S}^1)$ satisfies

$$u_k \rightarrow u \quad \text{in } L^\infty(K),$$

or, in other words, if $u_k \rightarrow u$ in $L^\infty_{\text{loc}}(\Omega \setminus \{x_1, \dots, x_m\}; \mathbb{R}^2)$. Therefore we are led to consider

$$\begin{aligned} \overline{\mathcal{A}}_{L^\infty}(u; \Omega) := \inf \left\{ \liminf_{k \rightarrow +\infty} \mathcal{A}(u_k; \Omega) : (u_k) \subset C^1(\Omega; \mathbb{R}^2), u_k \rightarrow u \text{ in } L^1(\Omega; \mathbb{R}^2) \right. \\ \left. \text{and } u_k \rightarrow u \text{ in } L^\infty_{\text{loc}}(\Omega \setminus \{x_1, \dots, x_m\}; \mathbb{R}^2) \right\}. \end{aligned} \quad (4.25)$$

It is then possible to show that

$$\overline{\mathcal{A}}_{L^\infty}(u; \Omega) = \int_{\Omega} \sqrt{1 + |\nabla u|^2} dx + \pi \sum_{i=1}^m |d_i|. \quad (4.26)$$

Notice that, if one considers the functional TVJ_{L^∞} , obtained by relaxing TVJ with this notion of convergence, the counterpart of Theorem 4.3 does not hold anymore, since we cannot guarantee a uniform bound on the L^1 norm of ∇v_k , needed to get (4.7); however, we gain such a control on $\|\nabla v_k\|_{L^1}$ in the area functional, as soon as the approximating sequence (v_k) has bounded area.

The proof of (4.26) is the same as the one of Theorem 1.2, with the difference that we can deduce straightforwardly the uniform convergence of (v_k) on almost every circumference in B_{r_1} , without passing through (4.5).

5. AN EXTENSION TO SYMMETRIC PIECEWISE CONSTANT $BV(\Omega; \mathbb{S}^1)$ MAPS

In this section we prove Theorem 1.3. Let us recall that a symmetric triple point map in \mathbb{R}^2 is a map $u = u_T : B_\ell(0) \subset \mathbb{R}^2 \rightarrow \mathbb{S}^1$ taking three values $\{\alpha, \beta, \gamma\} \subset \mathbb{S}^1$, vertices of an equilateral triangle, on three non-overlapping $2\pi/3$ -angular regions A, B, C with common vertex at the origin and interfaces a, b, c (see Fig. 1). We denote by $T_{\alpha\beta\gamma} \subset \mathbb{R}^2$ the triangle with vertices $\{\alpha, \beta, \gamma\}$, whose length side is $|\alpha - \beta| =: L = \sqrt{3}$, and by $J_u = a \cup b \cup c$ the jump set of u . We have $|T_{\alpha\beta\gamma}| = \frac{\sqrt{3}}{4} L^2 = \frac{3\sqrt{3}}{4}$, and $|Du|(B_\ell) = L\mathcal{H}^1(J_u) = 3L\ell$.

Proof of Theorem 1.3: upper bound. For simplicity of notation, in what follows we write

$$\varepsilon \text{ in place of } 1/k,$$

with $k \in \mathbb{N}$.

We construct a recovery sequence $(u^\varepsilon)_\varepsilon \subset \text{Lip}(B_\ell; \mathbb{R}^2)$ as $\varepsilon \rightarrow 0^+$. Let us consider the rectangle

$$R := \{(t, s) \in \mathbb{R}^2 : t \in (0, \ell), s \in (0, L)\}$$

and, for $\varepsilon \in (0, \ell)$, the functions $m^\varepsilon : R \rightarrow [0, +\infty)$ (whose graph is plotted in Fig. 2) defined as

$$m^\varepsilon(t, s) := \begin{cases} 0 & t \in [\varepsilon, \ell], \\ 2 \frac{\varepsilon - t}{\varepsilon} \frac{sh}{L} & t \in [0, \varepsilon), s \in [0, \frac{L}{2}], \\ 2 \frac{\varepsilon - t}{\varepsilon} \frac{(L-s)h}{L} & t \in [0, \varepsilon), s \in (\frac{L}{2}, L], \end{cases} \quad (5.1)$$

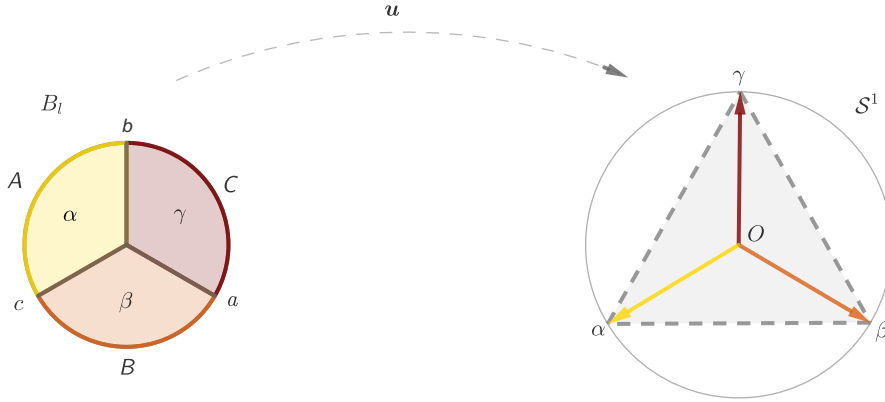

FIGURE 1. The symmetric triple point map: on the left the source disk $B_\ell(0)$, three-sided in the regions A, B, C , where u takes the values α, β, γ , depicted in the \mathbb{R}^2 target on the right.

where $h := \frac{L}{2\sqrt{3}} = \frac{1}{2}$. The number h is the height of each of the three isosceles triangles with common vertex at the origin of the target space that decompose $T_{\alpha\beta\gamma}$ (see Fig. 1 right). Let us denote by $S_\varepsilon^a, S_\varepsilon^b, S_\varepsilon^c$ three tiny stripes around a, b, c in B_ℓ , of width ε and length $\ell - \frac{\varepsilon}{2\sqrt{3}}$, drawn in Figure 3. More explicitly, we have

$$S_\varepsilon^b := \left\{ (x, y) \in B_\ell : |x| \leq \frac{\varepsilon}{2}, y \geq \frac{\varepsilon}{2\sqrt{3}} \right\},$$

and S_ε^a (S_ε^c) is obtained by clockwise rotating S_ε^b of an angle $\frac{2\pi}{3}$ ($\frac{4\pi}{3}$ respectively) around the origin.

The idea is to glue m^ε on each strip in order to build three surfaces embedded in \mathbb{R}^4 living in three non-collinear copies of \mathbb{R}^3 , whose total area contribution gives $|T_{\alpha\beta\gamma}|$ in the limit $\varepsilon \rightarrow 0^+$.

We introduce the affine diffeomorphism $\psi_\varepsilon : \left[\frac{\varepsilon}{2\sqrt{3}}, \ell \right] \rightarrow [0, \ell]$ such that

$$\psi'_\varepsilon(y) = \frac{\ell}{\ell - \frac{\varepsilon}{2\sqrt{3}}} =: k_\varepsilon \rightarrow 1 \quad \text{as } \varepsilon \rightarrow 0^+.$$

Now we can define u^ε on S_ε^b : we set

$$\xi := \frac{\gamma - \alpha}{L} \in \mathbb{S}^1, \quad \eta := -\xi^\perp = \beta,$$

(where ξ^\perp is the $\frac{\pi}{2}$ -counterclockwise rotation of ξ) and

$$u^\varepsilon(x, y) := \alpha + \left(\frac{L}{2} + \frac{Lx}{\varepsilon} \right) \xi + m^\varepsilon \left(\psi_\varepsilon(y), \frac{L}{2} + \frac{Lx}{\varepsilon} \right) \eta \quad \forall (x, y) \in S_\varepsilon^b.$$

In a similar way, we define u^ε on S_ε^a and S_ε^c . Setting $T^\varepsilon := \overline{B_{\varepsilon/\sqrt{3}} \setminus (S_\varepsilon^a \cup S_\varepsilon^b \cup S_\varepsilon^c)}$ and $A^\varepsilon := A \setminus (S_\varepsilon^a \cup S_\varepsilon^b \cup$

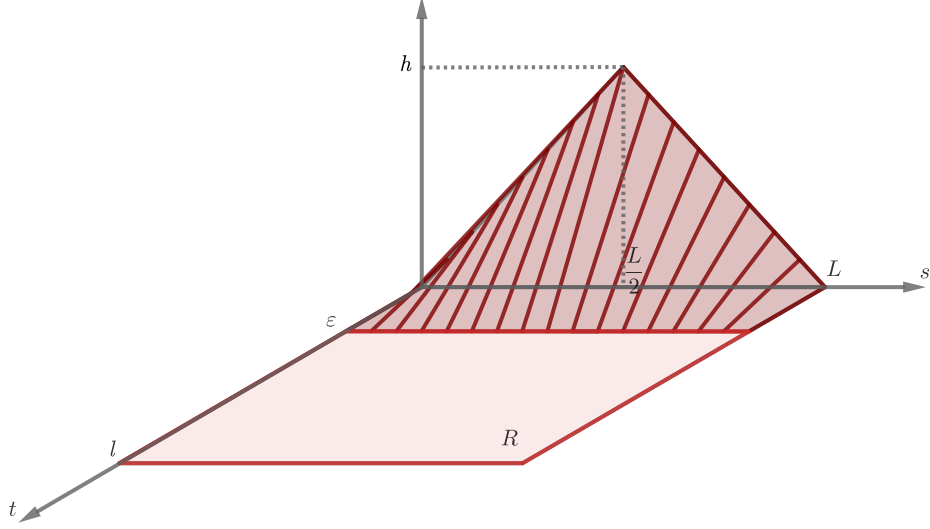
FIGURE 2. The graph of m^ε on the rectangle R .

$S_\varepsilon^c \cup T^\varepsilon$), $B^\varepsilon := B \setminus (S_\varepsilon^a \cup S_\varepsilon^b \cup S_\varepsilon^c \cup T^\varepsilon)$, $C^\varepsilon := C \setminus (S_\varepsilon^a \cup S_\varepsilon^b \cup S_\varepsilon^c \cup T^\varepsilon)$, we define:

$$u^\varepsilon := \begin{cases} \alpha & \text{in } A^\varepsilon, \\ \beta & \text{in } B^\varepsilon, \\ \gamma & \text{in } C^\varepsilon. \end{cases} \quad (5.2)$$

It remains to define u^ε on the small triangle T^ε . Let us divide it in four triangles $T_\varepsilon^a, T_\varepsilon^b, T_\varepsilon^c, T_\varepsilon^0$ (see Fig. 4). So, we set $u^\varepsilon = 0$ on T_ε^0 and let u^ε be the affine function that equals α (β, γ respectively), in the vertex of T^ε confining with A^ε ($B^\varepsilon, C^\varepsilon$ respectively), and equals 0 on the edge of T_ε^0 . A direct check shows that the function u_ε is Lipschitz continuous in B_ℓ .

Let us compute the area of the graph of u^ε on S_ε^b : denoting by $m_t^\varepsilon, m_s^\varepsilon$ the partial derivatives of m^ε , we have

$$\nabla u^\varepsilon(x, y) = \begin{pmatrix} \frac{L}{\varepsilon} \xi_1 + m_s^\varepsilon(\psi_\varepsilon(y), \frac{L}{2} + \frac{L}{\varepsilon} x) \frac{L}{\varepsilon} \eta_1 & m_t^\varepsilon(\psi_\varepsilon(y), \frac{L}{2} + \frac{L}{\varepsilon} x) k_\varepsilon \eta_1 \\ \frac{L}{\varepsilon} \xi_2 + m_s^\varepsilon(\psi_\varepsilon(y), \frac{L}{2} + \frac{L}{\varepsilon} x) \frac{L}{\varepsilon} \eta_2 & m_t^\varepsilon(\psi_\varepsilon(y), \frac{L}{2} + \frac{L}{\varepsilon} x) k_\varepsilon \eta_2 \end{pmatrix}. \quad (5.3)$$

Recalling that $\xi \cdot \eta = 0$ and $|\xi| = |\eta| = 1$, we can compute the square of the Frobenius norm of ∇u^ε :

$$\begin{aligned} |\nabla u^\varepsilon(x, y)|^2 &= \frac{L^2}{\varepsilon^2} [\xi_1^2 + (m_s^\varepsilon)^2 \eta_1^2 + 2\xi_1 \eta_1 m_s^\varepsilon + \xi_2^2 + (m_s^\varepsilon)^2 \eta_2^2 + 2\xi_2 \eta_2 m_s^\varepsilon] + (m_t^\varepsilon)^2 k_\varepsilon^2 \eta_1^2 + (m_t^\varepsilon)^2 k_\varepsilon^2 \eta_2^2 \\ &= \frac{L^2}{\varepsilon^2} (1 + (m_s^\varepsilon)^2) + (m_t^\varepsilon)^2 k_\varepsilon^2, \end{aligned} \quad (5.4)$$

where m_s^ε and m_t^ε are evaluated at $(\psi_\varepsilon(y), \frac{L}{2} + \frac{L}{\varepsilon} x)$. Moreover, using that $\xi \cdot \eta^\perp = 1$, we have

$$(\det \nabla u^\varepsilon)^2 = \frac{k_\varepsilon^2 L^2}{\varepsilon^2} [(\xi_1 \eta_2 m_t^\varepsilon + m_s^\varepsilon m_t^\varepsilon \eta_1 \eta_2) - (\xi_2 \eta_1 m_t^\varepsilon + m_s^\varepsilon m_t^\varepsilon \eta_1 \eta_2)]^2 = \frac{k_\varepsilon^2 L^2}{\varepsilon^2} (m_t^\varepsilon)^2.$$

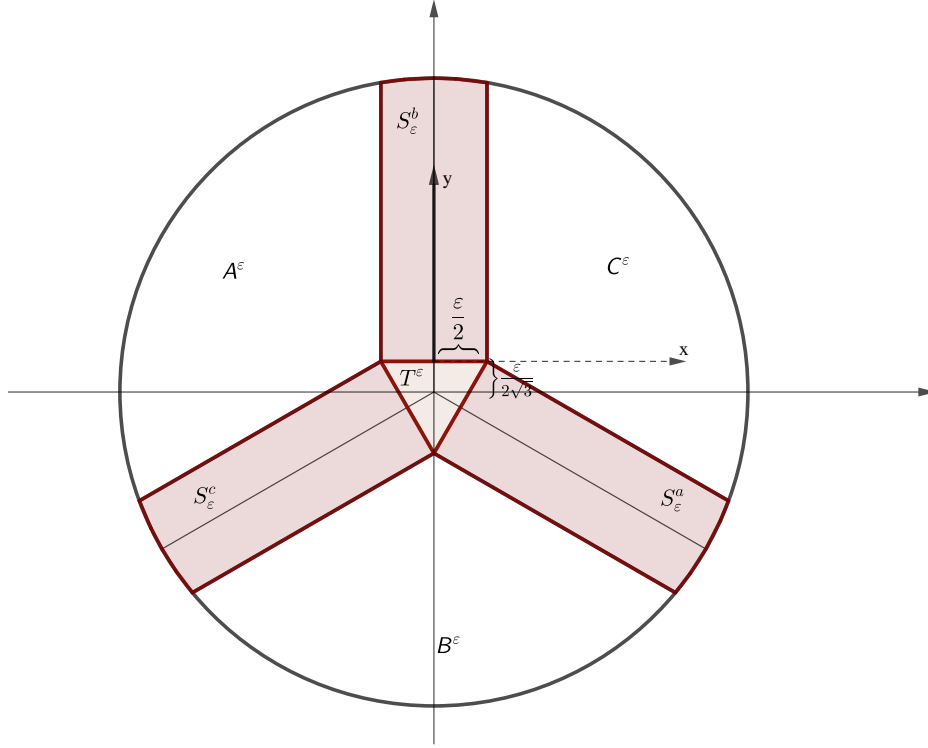

FIGURE 3. The strips $S_\varepsilon^a, S_\varepsilon^b, S_\varepsilon^c$ and the little triangle T^ε in the center.

So we have

$$\begin{aligned}
 \mathcal{A}(u^\varepsilon; S_\varepsilon^b) &= \int_{S_\varepsilon^b} \sqrt{1 + \frac{L^2}{\varepsilon^2} (1 + (m_s^\varepsilon)^2) + (m_t^\varepsilon)^2 k_\varepsilon^2 + \frac{k_\varepsilon^2 L^2}{\varepsilon^2} (m_t^\varepsilon)^2} dx dy \\
 &= \frac{L}{\varepsilon} \int_{S_\varepsilon^b} \sqrt{1 + m_s^\varepsilon \left(\psi_\varepsilon(y), \frac{L}{2} + \frac{L}{\varepsilon} x \right)^2 + m_t^\varepsilon \left(\psi_\varepsilon(y), \frac{L}{2} + \frac{L}{\varepsilon} x \right)^2 k_\varepsilon^2 \left(1 + \frac{\varepsilon^2}{L^2} \right) + O(\varepsilon^2)} dx dy \quad (5.5) \\
 &= \frac{1}{k_\varepsilon} \int_{R \setminus P_\varepsilon} \sqrt{1 + m_s^\varepsilon(t, s)^2 + m_t^\varepsilon(t, s)^2 k_\varepsilon^2 \left(1 + \frac{\varepsilon^2}{L^2} \right) + O(\varepsilon^2)} dt ds,
 \end{aligned}$$

where in the last equality we have performed the change of variables

$$(x, y) = \left(\frac{\varepsilon}{L} \left(s - \frac{L}{2} \right), \psi_\varepsilon^{-1}(t) \right) =: \phi_\varepsilon(t, s)$$

and we have set $P_\varepsilon = R \setminus \phi_\varepsilon^{-1}(S_\varepsilon^b)$. Notice that $\frac{1}{k_\varepsilon} \rightarrow 1$, $k_\varepsilon^2 \left(1 + \frac{\varepsilon^2}{L^2} \right) \rightarrow 1$ as $\varepsilon \rightarrow 0^+$, so that we get

$$\liminf_{\varepsilon \rightarrow 0^+} \mathcal{A}(u^\varepsilon; S_\varepsilon^b) \leq \int_R 1 dt ds + \liminf_{\varepsilon \rightarrow 0^+} \int_R |m_t^\varepsilon(t, s)| dt ds + \liminf_{\varepsilon \rightarrow 0^+} \int_R |m_s^\varepsilon(t, s)| dt ds. \quad (5.6)$$

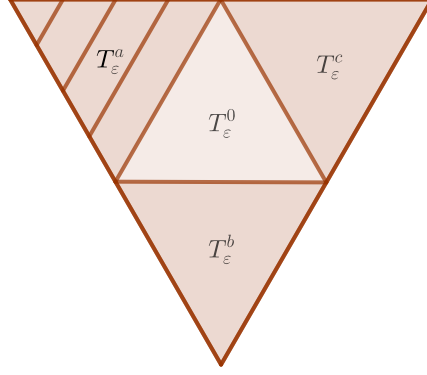
FIGURE 4. The triangle T^ε divided further in the four triangles $T_\varepsilon^a, T_\varepsilon^b, T_\varepsilon^c, T_\varepsilon^0$.

Let us compute explicitly the derivatives of m^ε :

$$m_t^\varepsilon(t, s) = \begin{cases} 0 & t > \varepsilon, \\ -2\frac{sh}{\varepsilon L} & t < \varepsilon, s < \frac{L}{2}, \\ -2\frac{(L-s)h}{\varepsilon L} & t < \varepsilon, s > \frac{L}{2}, \end{cases} \quad m_s^\varepsilon(t, s) = \begin{cases} 0 & t \geq \varepsilon, \\ 2\frac{\varepsilon-t}{\varepsilon} \frac{h}{L} & t < \varepsilon, s < \frac{L}{2}, \\ -2\frac{\varepsilon-t}{\varepsilon} \frac{h}{L} & t < \varepsilon, s > \frac{L}{2}. \end{cases}$$

Then, we obtain

$$\begin{aligned} \int_{\{t < \varepsilon, s < \frac{L}{2}\}} |m_t^\varepsilon(t, s)| dt ds &= \varepsilon \int_0^{\frac{L}{2}} 2\frac{sh}{\varepsilon L} ds = \frac{hL}{4}, \\ \int_{\{t < \varepsilon, s > \frac{L}{2}\}} |m_t^\varepsilon(t, s)| dt ds &= \varepsilon \int_{\frac{L}{2}}^L 2(L-s)\frac{sh}{\varepsilon L} ds = \frac{hL}{4}, \end{aligned}$$

so we get

$$\int_R |m_t^\varepsilon(t, s)| dt ds = \frac{hL}{4} + \frac{hL}{4} = \frac{hL}{2} \quad \forall \varepsilon > 0. \quad (5.7)$$

On the other hand,

$$\int_{\{t < \varepsilon, s < \frac{L}{2}\}} |m_s^\varepsilon(t, s)| dt ds = \int_{\{t < \varepsilon, s > \frac{L}{2}\}} |m_s^\varepsilon(t, s)| dt ds = \frac{L}{2} \int_0^\varepsilon 2\frac{\varepsilon-t}{\varepsilon} \frac{h}{L} ds = O(\varepsilon),$$

so we get

$$\liminf_{\varepsilon \rightarrow 0^+} \int_R |m_s^\varepsilon(t, s)| dt ds = 0. \quad (5.8)$$

Summarizing, from (5.6) we obtain

$$\liminf_{\varepsilon \rightarrow 0^+} \mathcal{A}(u^\varepsilon; S_\varepsilon^b) \leq \ell L + \frac{hL}{2}.$$

In the same way, we can prove that

$$\liminf_{\varepsilon \rightarrow 0^+} \mathcal{A}(u^\varepsilon; S_\varepsilon^a) = \liminf_{\varepsilon \rightarrow 0^+} \mathcal{A}(u^\varepsilon; S_\varepsilon^c) \leq \ell L + \frac{hL}{2}.$$

Clearly, the definition of u^ε on $A^\varepsilon, B^\varepsilon, C^\varepsilon$ provides that

$$\lim_{\varepsilon \rightarrow 0^+} \mathcal{A}(u^\varepsilon; A^\varepsilon \cup B^\varepsilon \cup C^\varepsilon) = |B_\ell| = \pi \ell^2.$$

It remains to show that the area contribution on T^ε is infinitesimal: first notice that

$$\mathcal{A}(u^\varepsilon; T_\varepsilon^0) = |T_\varepsilon^0| = O(\varepsilon^2).$$

Moreover on T_ε^a (respectively $T_\varepsilon^b, T_\varepsilon^c$) u^ε is the affine parameterization of the segment $(\alpha, 0)$ (respectively $(\beta, 0), (\gamma, 0)$) of the target space, therefore on $T^\varepsilon \setminus T_\varepsilon^0$ the area integrand has no Jacobian contribution and so is $O(\varepsilon^{-1})$, giving

$$\mathcal{A}(u^\varepsilon; T_\varepsilon^a) = \mathcal{A}(u^\varepsilon; T_\varepsilon^b) = \mathcal{A}(u^\varepsilon; T_\varepsilon^c) = O(\varepsilon).$$

Then we have

$$\mathcal{A}(u^\varepsilon; T^\varepsilon) = \mathcal{A}(u^\varepsilon; T_\varepsilon^0) + \mathcal{A}(u^\varepsilon; T_\varepsilon^a) + \mathcal{A}(u^\varepsilon; T_\varepsilon^b) + \mathcal{A}(u^\varepsilon; T_\varepsilon^c) = O(\varepsilon^2) + O(\varepsilon).$$

In the end, we conclude

$$\liminf_{\varepsilon \rightarrow 0^+} \mathcal{A}(u^\varepsilon; B_\ell) \leq \pi \ell^2 + 3\ell L + 3\frac{hL}{2},$$

where we recognize that the last quantity on the right-hand side is exactly $|T_{\alpha\beta\gamma}|$.

As a final step, we have to check that (u^ε) converges to u strictly $BV(B_\ell; \mathbb{R}^2)$. Clearly $u^\varepsilon \rightarrow u$ in $L^1(B_\ell; \mathbb{R}^2)$. Let us compute the total variation of u^ε : we have

$$|Du^\varepsilon|(B_\ell) = |Du^\varepsilon|(S_\varepsilon^a) + |Du^\varepsilon|(S_\varepsilon^b) + |Du^\varepsilon|(S_\varepsilon^c) + |Du^\varepsilon|(T^\varepsilon).$$

In particular,

$$|Du^\varepsilon|(T^\varepsilon) \leq \mathcal{A}(u^\varepsilon; T^\varepsilon) \rightarrow 0 \quad \text{as } \varepsilon \rightarrow 0^+.$$

Computing the variation on the strip S_ε^b (similarly for the other strips) we find

$$\begin{aligned} |Du^\varepsilon|(S_\varepsilon^b) &= \int_{S_\varepsilon^b} \sqrt{\frac{L^2}{\varepsilon^2} (1 + (m_s^\varepsilon)^2) + (m_t^\varepsilon)^2 k_\varepsilon^2} dx dy \\ &= \frac{L}{\varepsilon} \int_{S_\varepsilon^b} \sqrt{1 + m_s^\varepsilon \left(\psi_\varepsilon(y), \frac{L}{2} + \frac{L}{\varepsilon} x \right)^2 + m_t^\varepsilon \left(\psi_\varepsilon(y), \frac{L}{2} + \frac{L}{\varepsilon} x \right)^2 k_\varepsilon^2 \frac{\varepsilon^2}{L^2}} dx dy \\ &= \frac{1}{k_\varepsilon} \int_{R \setminus P_\varepsilon} \sqrt{1 + m_s^\varepsilon(t, s)^2 + m_t^\varepsilon(t, s)^2 k_\varepsilon^2 \frac{\varepsilon^2}{L^2}} dt ds. \end{aligned}$$

Then, using (5.7) and (5.8), we conclude

$$\limsup_{\varepsilon \rightarrow 0^+} |Du^\varepsilon|(S_\varepsilon^b) \leq \int_R 1 dt ds + \limsup_{\varepsilon \rightarrow 0^+} \int_R |m_s^\varepsilon(t, s)| dt ds + O(\varepsilon) \limsup_{\varepsilon \rightarrow 0^+} \int_R |m_t^\varepsilon(t, s)| dt ds = \ell L,$$

so that

$$\limsup_{\varepsilon \rightarrow 0^+} |Du^\varepsilon|(B_\ell) \leq 3\ell L.$$

By the lower semicontinuity of the variation, we get also

$$\liminf_{\varepsilon \rightarrow 0^+} |Du^\varepsilon|(B_\ell) \geq |Du|(B_\ell) = 3\ell L,$$

which shows the desired convergence of (u^ε) to u strictly $BV(B_\ell; \mathbb{R}^2)$. \square

Before proving the lower bound, similarly to Lemma 4.1, we show that the strict BV convergence is inherited to almost every circumference centered at the origin.

Lemma 5.1 (Inheritance). *Lemma 4.1 holds with u_T in place of u .*

Proof. Let $\rho < \ell$ and u be the triple point map; clearly

$$|D(u \llcorner \partial B_\rho)|(\partial B_\rho) = 3L. \quad (5.9)$$

On the other hand, since (v_k) converges to u in $L^1(B_\rho; \mathbb{R}^2)$, for almost every $\rho < \ell$ we have $v_k \llcorner \partial B_\rho \rightarrow u \llcorner \partial B_\rho$ in $L^1(\partial B_\rho; \mathbb{R}^2)$, and by lower semicontinuity we infer that

$$|D(u \llcorner \partial B_\rho)|(\partial B_\rho) \leq \liminf_{k \rightarrow +\infty} \int_{\partial B_\rho} \left| \frac{\partial v_k}{\partial s} \right| ds \quad \text{for a.e. } \rho < \ell. \quad (5.10)$$

Integrating with respect to $\rho \in (0, \ell)$, by (5.9) and Fatou's lemma, we have

$$|Du|(B_\ell) = 3\ell L = \int_0^\ell |D(u \llcorner \partial B_\rho)|(\partial B_\rho) d\rho \leq \int_0^\ell \liminf_{k \rightarrow +\infty} \int_{\partial B_\rho} \left| \frac{\partial v_k}{\partial s} \right| ds d\rho \leq \liminf_{k \rightarrow +\infty} \int_{B_\ell} |\nabla v_k| dx. \quad (5.11)$$

By assumption, (v_k) converges to u strictly $BV(B_\ell; \mathbb{R}^2)$, so we have all equalities in (5.11), in particular, using (5.10),

$$|D(u \llcorner \partial B_\rho)|(\partial B_\rho) = \liminf_{k \rightarrow +\infty} \int_{\partial B_\rho} \left| \frac{\partial v_k}{\partial s} \right| ds \quad \text{for a.e. } \rho < \ell.$$

Upon extracting a suitable subsequence (v_{k_h}) depending on ρ we get the conclusion. \square

Proof of Theorem 1.3 (lower bound). Let $(v_k) \subset C^1(B_\ell; \mathbb{R}^2)$ be a recovery sequence, i.e.,

$$v_k \rightarrow u \quad \text{strictly } BV(B_\ell; \mathbb{R}^2) \quad \text{and} \quad \lim_{k \rightarrow +\infty} \mathcal{A}(v_k; B_\ell) = \bar{\mathcal{A}}_{BV}(u; B_\ell).$$

Fix $\rho \in (0, \ell)$ and a subsequence (v_{k_h}) of (v_k) whose restriction to ∂B_ρ converges to $u \llcorner \partial B_\rho$ strictly $BV(\partial B_\rho; \mathbb{R}^2)$, as in Lemma 5.1. For simplicity, let us still denote v_{k_h} by v_k .

Let us split the area functional as

$$\mathcal{A}(v_k; B_\ell) = \mathcal{A}(v_k; B_\ell \setminus B_\rho) + \mathcal{A}(v_k; B_\rho).$$

On $B_\ell \setminus B_\rho$ we still have L^1 -convergence of (v_k) to u , but $u \llcorner (B_\ell \setminus B_\rho)$ has no triple points, so by Theorem 3.14 of [1],

$$\begin{aligned} \liminf_{k \rightarrow +\infty} \mathcal{A}(v_k; B_\ell \setminus B_\rho) &\geq \bar{\mathcal{A}}_{L^1}(u; B_\ell \setminus B_\rho) = \int_{B_\ell \setminus B_\rho} |\sqrt{1 + |\nabla u|^2}| dx + |D^j u|(B_\ell \setminus B_\rho) \\ &= |B_\ell \setminus B_\rho| + 3L(\ell - \rho) = \pi(\ell^2 - \rho^2) + 3L(\ell - \rho). \end{aligned}$$

Therefore

$$\begin{aligned} \lim_{k \rightarrow +\infty} \mathcal{A}(v_k; B_\ell) &\geq \liminf_{k \rightarrow +\infty} \mathcal{A}(v_k; B_\ell \setminus B_\rho) + \liminf_{k \rightarrow +\infty} \mathcal{A}(v_k; B_\rho) \\ &\geq \pi(\ell^2 - \rho^2) + 3L(\ell - \rho) + \liminf_{k \rightarrow +\infty} \int_{B_\rho} |Jv_k| dx, \end{aligned} \tag{5.12}$$

where as usual $Jv_k := \det \nabla v_k$.

Let us prove that

$$\liminf_{k \rightarrow +\infty} \int_{B_\rho} |Jv_k| dx \geq |T_{\alpha\beta\gamma}|, \tag{5.13}$$

from which the lower bound in (1.16) is obtained by passing to the limit as $\rho \rightarrow 0^+$ in (5.12). Now we observe that, since v_k is Lipschitz on B_ρ , it satisfies the following identity (see (2.7)):

$$\int_{B_\rho} Jv_k dx = \frac{1}{2} \int_{\partial B_\rho} \left((v_k)_1 \frac{\partial (v_k)_2}{\partial s} - (v_k)_2 \frac{\partial (v_k)_1}{\partial s} \right) ds \quad \forall k \in \mathbb{N}.$$

Let us parametrize ∂B_ρ from $[0, 2\pi)$ and set $\tilde{v}_k(t) := v_k(s(t))$ for $t \in [0, 2\pi)$; then

$$(\dot{\tilde{v}}_k)_i(t) = \frac{d}{dt}(v_k)_i(s(t)) = \rho \frac{\partial (v_k)_i}{\partial s}(s(t)), \quad i = 1, 2.$$

Thus we get

$$\int_{\partial B_\rho} \left((v_k)_1 \frac{\partial (v_k)_2}{\partial s} - (v_k)_2 \frac{\partial (v_k)_1}{\partial s} \right) ds = \int_0^{2\pi} \left((\tilde{v}_k)_1(t) \dot{(\tilde{v}_k)_2}(t) - (\tilde{v}_k)_2(t) \dot{(\tilde{v}_k)_1}(t) \right) dt.$$

Denoting $\tilde{v}_k(t)$ simply by $v_k(t)$, we can write

$$\int_{B_\rho} Jv_k dx = \frac{1}{2} \int_0^{2\pi} \left((v_k)_1(t) \dot{(v_k)_2}(t) - (v_k)_2(t) \dot{(v_k)_1}(t) \right) dt.$$

To show (5.13) it is sufficient to prove that

$$\liminf_{k \rightarrow +\infty} \frac{1}{2} \int_0^{2\pi} \left((v_k)_1(t) \dot{(v_k)_2}(t) - (v_k)_2(t) \dot{(v_k)_1}(t) \right) dt \geq |T_{\alpha\beta\gamma}|, \quad (5.14)$$

since obviously

$$\int_{B_\rho} |Jv_k| dx \geq \left| \int_{B_\rho} Jv_k dx \right|.$$

In order to show (5.14), denote by $\theta_1 \in [0, 2\pi)$ (respectively θ_2, θ_3) the angle of the middle point of the arc $C \cap \partial B_\rho$ (respectively $A \cap \partial B_\rho, B \cap \partial B_\rho$) and write

$$\begin{aligned} & \frac{1}{2} \int_0^{2\pi} \left((v_k)_1(t) \dot{(v_k)_2}(t) - (v_k)_2(t) \dot{(v_k)_1}(t) \right) dt \\ &= \frac{1}{2} \int_{\theta_1}^{\theta_2} \left((v_k)_1(t) \dot{(v_k)_2}(t) - (v_k)_2(t) \dot{(v_k)_1}(t) \right) dt \\ & \quad + \frac{1}{2} \int_{\theta_2}^{\theta_3} \left((v_k)_1(t) \dot{(v_k)_2}(t) - (v_k)_2(t) \dot{(v_k)_1}(t) \right) dt \\ & \quad + \frac{1}{2} \int_{\theta_3}^{\theta_1} \left((v_k)_1(t) \dot{(v_k)_2}(t) - (v_k)_2(t) \dot{(v_k)_1}(t) \right) dt. \end{aligned} \quad (5.15)$$

Notice that, as a consequence of Lemma 5.1, v_k converges to u strictly $BV([\theta_1, \theta_2]; \mathbb{R}^2)$. Furthermore, by restricting v_k to $[\theta_1, \theta_1 + \delta]$, for a small $\delta > 0$, as a consequence of Proposition 2.4 we see that v_k converges uniformly to $v \equiv \gamma$ on $[\theta_1, \theta_1 + \delta]$. In particular we have

$$\lim_{k \rightarrow \infty} v_k(\theta_1) = \gamma.$$

Similarly v_k will tend to α and β in θ_2 and θ_3 , respectively. We set

$$L_k := \int_{\theta_1}^{\theta_2} \left(|\dot{v}_k(t)| + \frac{1}{k} \right) dt, \quad z(t) = z_k(t) := \int_{\theta_1}^t \left(|\dot{v}_k(\tau)| + \frac{1}{k} \right) d\tau, \quad t \in [\theta_1, \theta_2].$$

Since z is strictly increasing with derivative bounded from below by $\frac{1}{k}$, we can invert it and denote its inverse $t(z)$. We define $w_k : [0, L_k] \rightarrow \mathbb{R}^2$ as

$$w_k(z) = v_k(t(z)).$$

Then we have

$$w'_k(z) = \dot{v}_k(t(z)) \frac{dt}{dz} = \frac{\dot{v}_k(t(z))}{|\dot{v}_k(t(z))| + \frac{1}{k}}, \quad dt = \frac{1}{|\dot{v}_k(t(z))| + \frac{1}{k}} dz.$$

Thus, $(w_k)_k$ is uniformly Lipschitz continuous on $[0, L_k]$ (with modulus of derivative bounded by 1), and

$$\frac{1}{2} \int_{\theta_1}^{\theta_2} ((v_k)_1(t)(\dot{v}_k)_2(t) - (v_k)_2(t)(\dot{v}_k)_1(t)) dt = \frac{1}{2} \int_0^{L_k} ((w_k)_1(z)(w'_k)_2(z) - (w_k)_2(z)(w'_k)_1(z)) dz. \quad (5.16)$$

We also have

$$\lim_{k \rightarrow +\infty} L_k = \lim_{k \rightarrow +\infty} \int_{\theta_1}^{\theta_2} \left(|\dot{v}_k(t)| + \frac{1}{k} \right) dt = |Du| \llcorner \{y \in \partial B_\rho : \arg(y) \in [\theta_1, \theta_2]\} = |\gamma - \alpha| = L.$$

We further reparametrize w_k on $[0, L]$ by a multiple of the arc length parameter. Still denoting the obtained function by $(w_k)_k$, we see that w_k is uniformly bounded in $W^{1,\infty}([0, L]; \mathbb{R}^2)$ so, upon passing to a (not relabelled) subsequence, we have

$$w_k \xrightarrow{*} w \quad \text{w*}-W^{1,\infty}([0, L]; \mathbb{R}^2),$$

for some $w \in W^{1,\infty}([0, L]; \mathbb{R}^2)$. Hence, we can pass to the limit in (5.16), which now reads

$$\frac{1}{2} \int_0^L ((w_k)_1(z)(w'_k)_2(z) - (w_k)_2(z)(w'_k)_1(z)) dz \xrightarrow{k \rightarrow +\infty} \frac{1}{2} \int_0^L (w_1(z)w'_2(z) - w_2(z)w'_1(z)) dz. \quad (5.17)$$

Recalling that

$$\begin{aligned} w(0) &= \lim_{k \rightarrow +\infty} w_k(0) = \lim_{k \rightarrow +\infty} v_k(\theta_1) = \gamma, \\ w(L) &= \lim_{k \rightarrow +\infty} w_k(L) = \lim_{k \rightarrow +\infty} w_k(L_k) = \lim_{k \rightarrow +\infty} v_k(\theta_2) = \alpha, \end{aligned}$$

we see that w is a 1-Lipschitz curve on $[0, L]$ starting from γ and ending at α ; therefore it must coincide with the unit speed parameterization of the segment connecting γ to α , *i.e.*,

$$w(z) = \gamma + \frac{\alpha - \gamma}{L} z.$$

So, we can easily compute the limit integral in (5.17):

$$\begin{aligned} \frac{1}{2} \int_0^L (w_1(z)w'_2(z) - w_2(z)w'_1(z)) dz &= -\frac{1}{2} \int_0^L \left(\gamma + \frac{\alpha - \gamma}{L} z \right) \cdot \frac{(\alpha - \gamma)^\perp}{L} dz = -\frac{1}{2} \gamma \cdot (\alpha - \gamma)^\perp \\ &= \frac{1}{2} (\gamma_1 \alpha_2 - \gamma_2 \alpha_1) = |T_{\alpha 0 \gamma}|, \end{aligned}$$

where $T_{\alpha 0 \gamma}$ is the triangle with vertices α , γ and the origin 0. We conclude that

$$\lim_{k \rightarrow +\infty} \frac{1}{2} \int_{\theta_1}^{\theta_2} ((v_k)_1(t)(\dot{v}_k)_2(t) - (v_k)_2(t)(\dot{v}_k)_1(t)) dt = |T_{\alpha 0 \gamma}|.$$

In a similar way, one can prove that

$$\lim_{k \rightarrow +\infty} \frac{1}{2} \int_{\theta_2}^{\theta_3} ((v_k)_1(t)(\dot{v}_k)_2(t) - (v_k)_2(t)(\dot{v}_k)_1(t)) dt = |T_{\alpha_0\beta}|,$$

$$\lim_{k \rightarrow +\infty} \frac{1}{2} \int_{\theta_3}^{\theta_1} ((v_k)_1(t)(\dot{v}_k)_2(t) - (v_k)_2(t)(\dot{v}_k)_1(t)) dt = |T_{\beta_0\gamma}|,$$

and (5.14) follows. \square

Remark 5.2. A result similar to Theorem 1.3 holds, up to trivial modifications, when $u : B_\ell(0) \rightarrow \mathbb{S}^1$ is a symmetric n -junction map, taking (in the order) the values $\alpha_1, \dots, \alpha_n$ vertices of the regular n -gon $P_{\alpha_1 \dots \alpha_n}$ inscribed in the unit circle, on n non-overlapping $2\pi/n$ -angular regions with common vertex at the origin. In formulas, let L be the side of $P_{\alpha_1 \dots \alpha_n}$ and h be the height of each isosceles triangle that decomposes $P_{\alpha_1 \dots \alpha_n}$, then there holds the following.

Corollary 5.3. *Let $u : B_\ell(0) \rightarrow \mathbb{S}^1$ be a symmetric n -junction map. Then*

$$\overline{A}_{BV}(u, B_\ell) = |B_\ell| + |Du|(B_\ell) + |P_{\alpha_1 \dots \alpha_n}| = \pi\ell^2 + nL\ell + \frac{n}{2}hL.$$

REFERENCES

- [1] E. Acerbi and G. Dal Maso, New lower semicontinuity results for polyconvex integrals. *Calc. Var. Partial Differ. Equ.* **2** (1994) 329–371.
- [2] L. Ambrosio, N. Fusco and D. Pallara, “Functions of Bounded Variation and Free Discontinuity Problems”, Oxford Mathematical Monographs. Oxford University Press, New York (2000).
- [3] G. Bellettini, A. Elshorbagy, M. Paolini and R. Scala, On the relaxed area of the graph of discontinuous maps from the plane to the plane taking three values with no symmetry assumptions. *Ann. Mat. Pura Appl.* **199** (2020) 445–477.
- [4] G. Bellettini, A. Elshorbagy and R. Scala, The L^1 -relaxed area of the graph of the vortex map. Preprint [arXiv:2107.07236](https://arxiv.org/abs/2107.07236) (2021).
- [5] G. Bellettini, R. Marziani and R. Scala, A non-parametric Plateau problem with partial free boundary. Preprint [arXiv:2201.06145](https://arxiv.org/abs/2201.06145) (2022).
- [6] G. Bellettini and M. Paolini, On the area of the graph of a singular map from the plane to the plane taking three values. *Adv. Calc. Var.* **3** (2010) 371–386.
- [7] G. Bellettini, M. Paolini and L. Tealdi, On the area of the graph of a piecewise smooth map from the plane to the plane with a curve discontinuity. *ESAIM: COCV* **22** (2015) 29–63.
- [8] G. Bellettini, M. Paolini and L. Tealdi, Semicartesian surfaces and the relaxed area of maps from the plane to the plane with a line discontinuity. *Ann. Mat. Pura Appl.* **195** (2016) 2131–2170.
- [9] H. Brezis, P. Mironescu and A. Ponce, $W^{1,1}$ -maps with values into \mathbb{S}^1 . *Geometric analysis of PDE and several complex variables*, 69–100, Contemp. Math., 368, Amer. Math. Soc., Providence, RI (2005).
- [10] G. Dal Maso, Integral representation on $BV(\Omega)$ of Γ -limits of variational integrals. *Manuscr. Math.* **30** (1980) 387–416.
- [11] E. De Giorgi, On the relaxation of functionals defined on cartesian manifolds. In “Developments in Partial Differential Equations and Applications in Mathematical Physics” (Ferrara 1992). Plenum Press, New York (1992).
- [12] G. De Philippis, Weak notions of Jacobian determinant and relaxation. *ESAIM: COCV* **18** (2012) 181–207.
- [13] M. Giaquinta, G. Modica and J. Souček, “Cartesian Currents in the Calculus of Variations I”, Vol. 37 of *Ergebnisse der Mathematik und ihrer Grenzgebiete*. Springer-Verlag, Berlin-Heidelberg (1998).
- [14] M. Giaquinta, G. Modica and J. Souček, Cartesian Currents in the Calculus of Variations II. Variational Integrals. Vol. 38 of *Ergebnisse der Mathematik und ihrer Grenzgebiete*. Springer-Verlag, Berlin-Heidelberg (1998).
- [15] E. Giusti, Minimal Surfaces and Functions of Bounded Variation. Birkhäuser, Boston (1984).
- [16] C. Hamburger, Some properties of the degree for a class of Sobolev maps. *Proc. Math. Phys. Eng. Sci.* **455** (1999) 2331–2349.
- [17] R.L. Jerrard and H.M. Soner, Functions of bounded higher variation. *Indiana Univ. Math. J.* **51** (2002) 645–677.
- [18] S. Müller, T. Qi and B.S. Yan, On a new class of elastic deformations not allowing for cavitation. *Inst. H. Poincaré Anal. Non Linéaire* **11** (1994) 217–243.
- [19] P. Mironescu, Sobolev maps on manifolds: degree, approximation, lifting. Perspectives in nonlinear partial differential equations. *Contemp. Math.* **446** (2007) 413–436.
- [20] E. Paolini, On the relaxed total variation of singular maps. *Manuscr. Math.* **111** (2003) 499–512.
- [21] A.C. Ponce and J. Van Schaftingen, Closure of smooth maps in $W^{1,p}(B^3, S^2)$. *Differ. Integr. Equ.* **22** (2009) 881–900.

- [22] R. Scala, Optimal estimates for the triple junction function and other surprising aspects of the area functional. *Ann. Sc. Norm. Super. Pisa Cl. Sci. (5)* **20** (2020) 491–564.

Subscribe to Open (S2O)

A fair and sustainable open access model



This journal is currently published in open access under a Subscribe-to-Open model (S2O). S2O is a transformative model that aims to move subscription journals to open access. Open access is the free, immediate, online availability of research articles combined with the rights to use these articles fully in the digital environment. We are thankful to our subscribers and sponsors for making it possible to publish this journal in open access, free of charge for authors.

Please help to maintain this journal in open access!

Check that your library subscribes to the journal, or make a personal donation to the S2O programme, by contacting subscribers@edpsciences.org

More information, including a list of sponsors and a financial transparency report, available at: <https://www.edpsciences.org/en/math-s2o-programme>