

Lithium-Lead/water interaction: LIFUS5/Mod3 series E tests analysed by SIMMER-III coupled with RELAP5

V. Cossu^{a,*}, F. Galleni^a, M. Eboli^b, A. Del Nevo^b, N. Forgiione^a, S. Paci^a

^a LSTN, DIC1, Università di Pisa, L.go Lucio Lazzarino n. 2, Pisa 56122, Italy

^b ENEA FSN-ING-SIS, CR Brasimone, Camugnano, BO 40032, Italy

ARTICLE INFO

Keywords:

SIMMER-III code
RELAP5
Coupling
WCLL-TBM, In-box LOCA
Lead-lithium-water

ABSTRACT

The Breeding Blanket is a necessary component to close the nuclear fusion reactor fuel cycle. amongst the most promising conceptual design, there is the Water Cooled Lithium Lead Breeding Blanket, with water as coolant and eutectic Lithium-Lead as neutron multiplier and breeder. The possible interaction between water and Lithium-Lead poses a main safety concern and prompted the scientific community to develop a numerical analysis tool able to simulate such a complex interaction. The SIMMER-III code was modified by UNIPI to simulate the chemical interaction between water and Lithium-Lead, furthermore also a coupling methodology between SIMMER-III and RELAP5/Mod3.3 was developed. The coupling tool employs SIMMER-III code to simulate the zone of Lithium-Lead interacting with water, whilst the RELAP5 code is used to simulate the water pipelines. The LIFUS5/Mod3 facility at the ENEA Brasimone Research Centre was designed to perform reliable experimental activities on the interaction between water and Lithium-Lead. In this facility water at high pressure is injected inside a reaction vessel, where the thermodynamic and chemical interaction between water and Lithium-Lead occurs. The experimental activities are divided in different tests matrix, the Series D and Series E tests. The two series differ in the amount of water injected during the transient. In series D the mass of water is predetermined whilst in series E water was injected continuously for a pre-fixed interval of time and the total injected mass was estimated a posteriori. This work shows the results of the coupling tool applied to Series E. The comparison between the experimental and numerical results is performed by identifying and characterizing the phenomena involved in the interaction. Furthermore, the overall performance of the coupled codes in the simulation of the phenomena is presented here.

1. Introduction

The Water Cooled Lithium Lead Breeding Blanket (WCLL-BB) is amongst the most promising design of the BB; in this configuration the liquid metal Lithium-Lead is used as tritium breeder and neutron multiplier whereas water is used as coolant. It has been chosen as a candidate for the DEMO nuclear fusion reactor [1–6]. One of the critical issues for this BB design is the not negligible probability of Loss of Coolant Accident (LOCA) in the breeding zone, due to the great number of water cooling tubes. The interaction between the Lithium/Lead alloy and water poses a main safety concern. The interaction is characterized by a thermodynamic response due to the high pressure of water and the high temperatures of both fluids. Furthermore, the exothermic reaction between lithium and water contributes to increase the pressure and temperature during this kind of accident and poses a safety risk due to

the production of hydrogen. To evaluate the integrity of the Breeding Blanket design after this kind of accident an intense literature review on the numerical tools available was performed. The complexity of the interaction and its importance for the WCLL-BB design, led to the modification of the SIMMER-III and SIMMER-IV, implementing the chemical reaction between the two fluids [7].

On this framework, an experimental facility at ENEA Brasimone, LIFUS5/Mod3 was built in order to obtain experimental data on the interaction between Lead-Lithium and water; the experimental campaign was divided in two series of tests, namely D and E series. The main objective of this facility was to generate a reliable experimental database used to perform the validation of the SIMMER-III and SIMMER-IV codes [8]. Another important objective was to better understand the interaction between the two fluids; indeed, it was possible to well define the phenomenological windows of the interaction and to understand

* Corresponding author.

E-mail address: vittorio.cossu@phd.unipi.it (V. Cossu).

<https://doi.org/10.1016/j.fusengdes.2023.113537>

Received 11 October 2022; Received in revised form 19 December 2022; Accepted 1 February 2023

Available online 7 February 2023

0920-3796/© 2023 The Authors. Published by Elsevier B.V. This is an open access article under the CC BY license (<http://creativecommons.org/licenses/by/4.0/>).

qualitatively the effect of a possible in-box LOCA [9,10]. Following the main objective of LIFUS5/Mod3, a numerical analysis of the various tests has been carried out. The simulations are performed using SIMMER-III and SIMMER-IV as well as a coupling tool composed by RELAP5/Mod3.3 and SIMMER-III or RELAP5 and SIMMER-IV [11,12].

In this paper the test E4.1 from Series E is analysed using the coupled numerical tool RELAP5/Mod3.3/SIMMER-III. Two parametric studies were carried out, one on the pressure drop coefficient of the injector device and the other one on the chemical reaction rate coefficient between Lithium-Lead and water. The two parametric studies set a range of values for these coefficients but also underline the possibility of further investigation on the chemical kinetics, which has a relevant impact on the transient evolution of the system.

This paper is divided into Section 2, where a description of LIFUS5/Mod3 and of the experimental Series E is shown; Section 3, where the nodalization and methodology of the numerical analysis are shown; Section 4, where the results are presented and a discussion on the numerical analysis is carried on and eventually Section 5 where the conclusions and further investigation are shown.

2. LIFUS5/Mod3

2.1. Facility description

LIFUS5/Mod3 is a separate effect test facility designed and built in ENEA Brasimone. It is designed to operate with Liquid Metals in different conditions and to operate in both high and low pressure environments. The facility has been employed, within the framework of EUROfusion, to investigate the Lithium-Lead water interaction, increasing the knowledge of the phenomena connected to the interaction and to validate the modification of SIMMER-III.

The facility is composed by 5 main components:

- 1 The reaction vessel S1B where the interaction between water and PbLi occurs.
- 2 The injection line SBL, is used to bring water at the experiment condition and with a connection on the bottom of the S1B, is used to inject the water.
- 3 A safety expansion vessel S3V connected with two rupture disk to the S1B, to avoid over pressurization of the facility.
- 4 PbLi storage tanks S4B1 and S4B2, for fresh and used lithium-lead alloy.
- 5 The hydrogen and measurement line.

The P&ID of the facility is reported in Fig. 1.

The reaction vessel is filled with PbLi and Argon as inert covered gas and is connected to the SBL through the injection line with the injector device. The latter one is composed by an orifice covered by a protective cap which is designed to break once a certain pressure is reached. In this way is possible to inject water at the pressure required by the experimental test matrix. [9]

2.2. Experimental test series E

LIFUS5/Mod3 facility was used to perform two different Series of experiments. The Series D and the Series E. The main difference between these two series of experiments is that during Series D a precise amount of water was loaded in the injection line and brought to the WCLL-BB conditions before the injection. Whilst the Series E is characterized by a continuous injection of water inside the S1B and the amount of water injected is determined by the diameter of the orifice and the injection time.

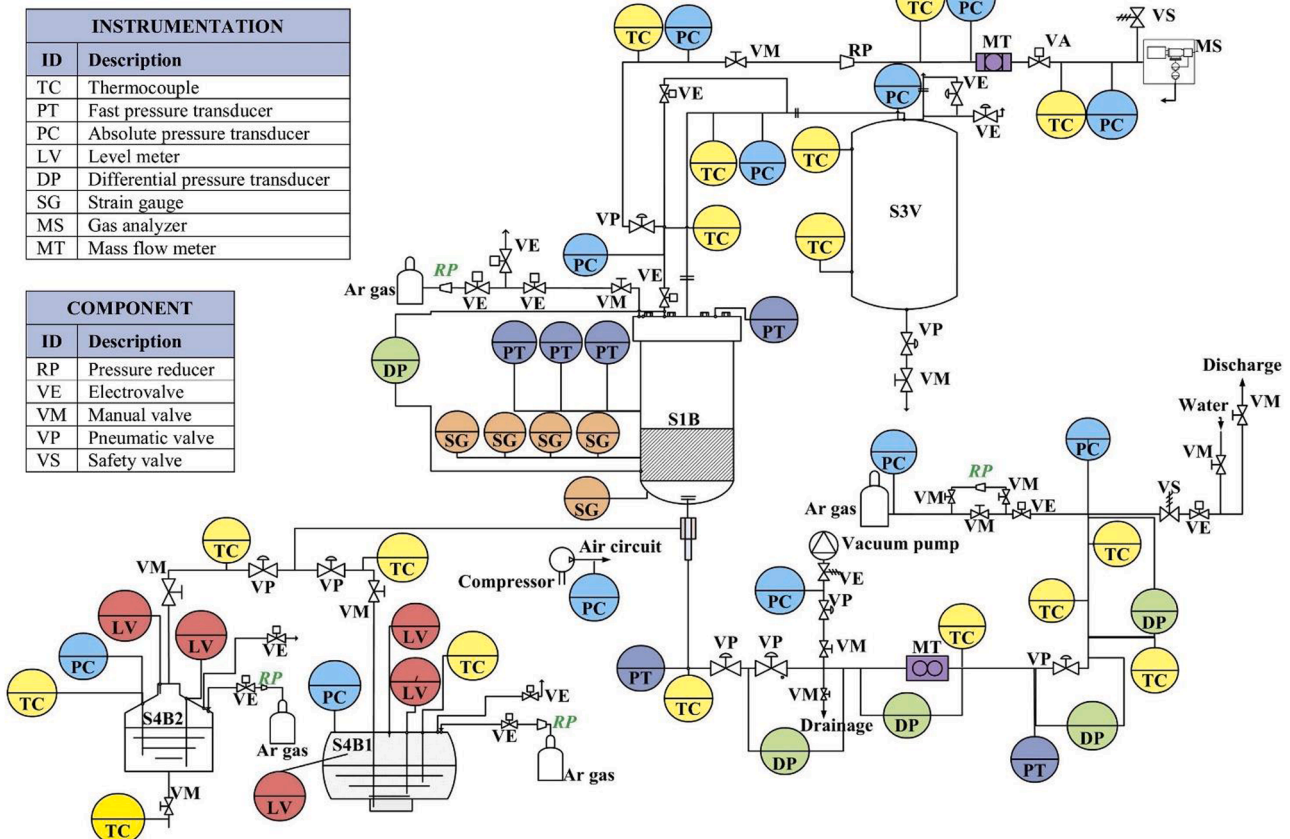

Fig. 1. LIFUS5/Mod3P&ID.

The numerical activity presented hereafter regards the test E4.1, which belongs to the Series E test matrix. In this experiment, water is injected at about the design pressure of WCLL-BB and the duration of the injection is about 1 second. The relevant initial and boundary data are registered by an appropriate system of measurement and they are summarized in Table 1.

3. Nodalization and methodology

The numerical analysis has been carried out with SIMMER-III and RELAP5/Mod3.3. This methodology allows to divide the domain of the numerical simulation for the different suitability of the two codes. Indeed, RELAP5 code is well known and widely used in the nuclear industry to simulate the transient and steady-state conditions of large nuclear power plants. It performs particularly well simulating pipelines and, more broadly, geometries characterised by one-dimensional evolution, so it is well suited to simulate the injection line of LIFUS5/Mod3. SIMMER-III is an axial-symmetric fluid dynamic code, which can manage more than one component (i.e., working fluid) and more than one phase in the same computational domain, hence it is suitable to simulate the reaction vessel zone where the water and PbLi interaction occurs. The two codes are coupled together through a MATLAB interface where the consistency at the interface is checked, and the advancement of the time steps is managed. The decomposition methodology is used to simulate the two domains and a semi-implicit method is used as numerical scheme for the coupling interface, choosing the convergence criteria and repeating the same time-step until convergence is reached. For the sake of conciseness, the methodology behind this coupling technique is not presented here, but the interested reader can find further information in several published works [9–11,13,14]

As part of the numerical analysis performed for the test E4.1, two parametric studies on two different parameters have been carried out. The first one is on the pressure drop coefficient orifice of the injector device (CORFZ) whilst the second parametric study is on a parameter that influences the reaction rate of the chemical reaction (FKCR).

3.1. Geometry and boundary and initial conditions

The SIMMER-III nodalization (Fig. 2) is composed of 50 radial and 77 axial mesh cells, and its computational domain models the S1B vessel with all the internal components. The steel test section structure inside the S1B which holds the measurement probes is modelled as SIMMER structural material cell mesh, as a series of axial tubes with lateral connections, representing the test section, connected with radial meshes representing the upper and lower plates. The expansion line and the hydrogen extraction line are also modelled inside this domain. The final part of the injection line is also discretized with SIMMER-III and the injector device is simulated as a virtual wall. The hemispherical part of the reaction is modelled using non-calculation zones and trying to keep the domain volume as equal as possible to the real volume of the system. Non-calculation cells are regions which are not considered in the calculation by the code and therefore can be used to shape the geometry.

The injection line is simulated with RELAP5/Mod3.3 reproducing all the main features of the line. It is composed by two time-dependant volumes, one representing the argon tank which is used to inject

water inside the S1B and the other one is instead used to couple the two domains. The single junctions are used to connect the various pipes element when they are not connected through valves element. The three valves present in the injection line are modelled in RELAP5/Mod3.3, two of them are isolation valves, whereas the latter one is the injection valve and its opening is regulated by a linear opening law. The bends and other components that generate pressure drops along the lines are simulated with pressure drop coefficients along the pipe elements, for example the Coriolis flow metre. The nodalization scheme is shown in Fig. 2.

The SIMMER-III domain contains initially PbLi and Argon gas as cover gas, at temperatures and pressure presented in Table 1, which corresponds to the initial condition of the experimental test. The level reached by PbLi is also obtained from the experimental data. In Fig. 2 it is possible to see the SIMMER-III domain and in particular in red the PbLi and in white the Argon gas. The RELAP5/Mod3.3 is also initialized considering the values of the experimental campaign reported in Table 1.

The RELAP5/Mod3.3 boundary conditions were obtained from the experimental data. The experimental pressure of the argon gas tank is used as boundary condition in RELAP5 for the injection line, imposing exactly the same transient signal recorded in the experiment through a probe located immediately downwind of the tank. Both temperatures and pressures were imposed by means of a numerical component, namely a time-dependant volume, which represents the argon gas tank (TMDPVOL 106 in Fig. 2). There is an adiabatic condition for all the volume type components in the nodalization.

The SIMMER-III domain boundary conditions are the adiabatic conditions of the reaction vessel and the virtual wall opening that simulates the orifice cap rupture.

3.2. Parametric studies

As stated in the introduction of Section 3, the parametric studies are performed for the CORFZ and the FKCR values, changing their values in the input deck of SIMMER-III.

The CORFZ is associated with the concentrated pressure drop, it is seen by SIMMER-III as a source of pressure drop and is equal to the usual pressure drop coefficient called “k”. This coefficient is used in the momentum equation for the various field and it generates pressure losses following equation (3-1)

$$\Delta p = -CORFZ \cdot \rho \cdot |v|^2 \quad (1)$$

The CORFZ parametric study is performed mainly because of some uncertainties on the injector device pressure drop coefficient, since after the abrupt cap rupture the cross section of the orifice might slightly differ from the nominal one, or that might be some blockages due to accumulation of small quantities of Lead-Lithium. The influence of the CORFZ on the water injected is especially important, indeed its variation is the main parameter influencing the water injected inside the S1B which in turn strongly affects the transient evolution, due to the thermodynamic and chemical interaction between water and PbLi.

The values of CORFZ simulated are reported in Table 2.

The second parametric study involves FKCR as parameter and it is performed by fixing CORFZ and using for it the value which guarantees an amount of injected water inside the S1B as close as possible to the experimental estimation. The FKCR coefficient is a limiting coefficient implemented in the chemical reaction model of SIMMER code. It is a limiting factor on the quantity of water that will react in the unity of time, thus it means that it will influence the chemical reaction rate between the two fluids. It is important to underline that chemical kinetics is a combination of contact area between the fluids that is strictly related to the flow regime of the fluids but also to the diffusion phenomena and surface kinetics, which together determine the global velocity of the reaction. The FKCR is used inside the chemical routine to calculate the

Table 1
Test E4.1 most important experimental values.

Parameter	Unit	Design	Actual
Pressure S1B	[bar]	1	0.7
Temperature PbLi	[°C]	330	333.9
Pressure SBL	[bar]	155	158.7
Temperature SBL	[°C]	295	274.7
Injection duration	[s]	1.0	0.9274
Cap rupture instant	[s]	[-]	0.2294
Pressure of cap rupture	[bar]	155	146.3

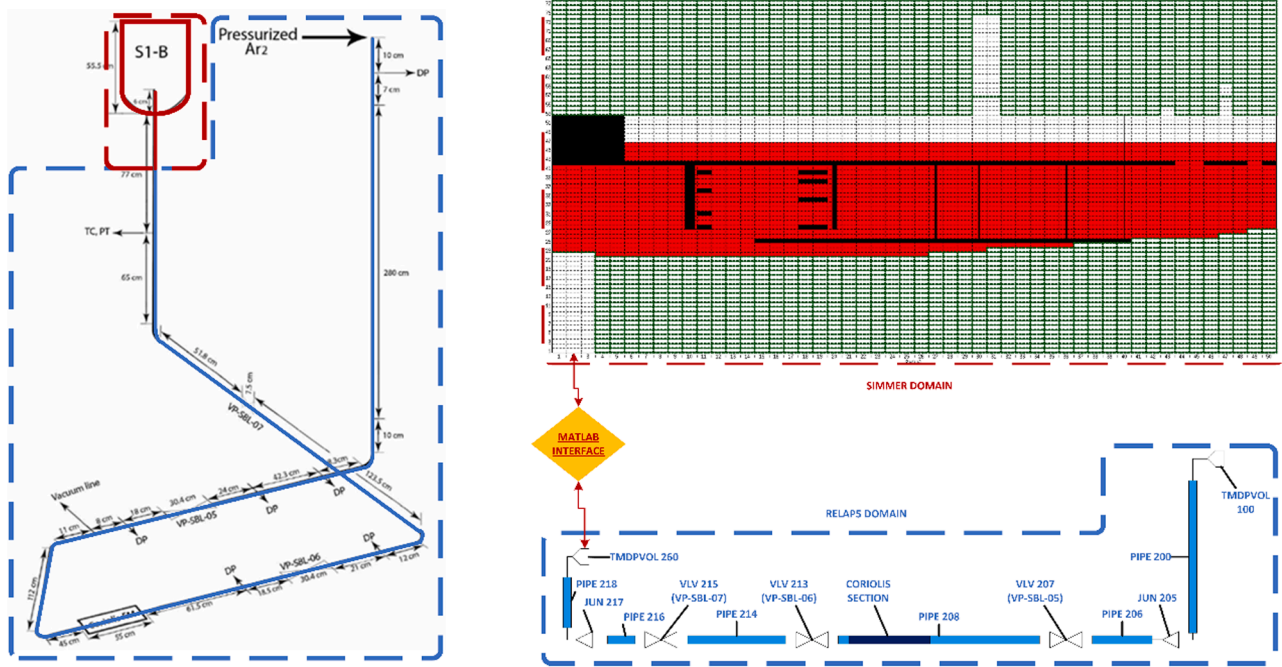

Fig. 2. Nodalization scheme of LIFUS5/Mod3.3.

Table 2
CORFZ values for the parametric study.

Case	#1	#2	#3	#4	#5	#6	#7	#8	#9	#10	#11	#12	#13
CORFZ	0.0	0.001	0.005	0.0075	0.01	0.05	0.075	0.5	1.0	2.5	5.0	7.5	10.0

hydrogen produced and thus the Lithium-Lead and water depleted during the interaction, following equation 3.2.

$$H2RS = WMH2 \cdot FKCR \cdot BCA \cdot XH20 \cdot XLI \tag{2}$$

Where *WMH2* is the molecular hydrogen molecular weight, *BCA* is the binary contact area between the two fluids which is calculated by SIMMER-III using the flow regimes maps, *XH20* and *XLI* are the Lithium and water volumetric concentrations. The chemical kinetics models are under investigation and their possibility to be implemented in SIMMER-III. However, varying the values of the coefficient is possible to vary the interaction between the PbLi and water and consequently the evolution of the whole transient. The values of FKCR simulated are reported in Table 3.

The numerical results are explained in the following section where the analysis of water injected is performed for both parametric studies and eventually a discussion on the pressurization of the reaction vessel, related to the quantity of water injected, is carried out for both the parametric studies.

4. Results and discussion

The simulated CORFZ values are reported in Table 2; in this parametric study the chemical interaction between water and lithium-lead is deactivated inside SIMMER-III. In this way it is possible to see the effect of the pressure drop coefficient on the transient evolution. It is also possible to underline the importance of the chemical reaction in the

Table 3
FKCR values for parametric study.

Case	#1	#2	#3	#4	#5	#6
FKCR	1.0E-3	1.0E-4	1.0E-5	1.0E-6	1.0E-7	1.0E-8

evolution of the system.

The results are reported in Fig. 3, where on the top there are the water injected values at the end of the injection for various values of CORFZ (Fig. 3a and 3b), whilst on the bottom the pressure evolution during the injection (Fig. 3c).

It is possible to see that only low values of CORFZ are in line with the water injected inside the S1B during the experimental test. In fact, only values of CORFZ from 0.0 to 0.075 can reproduce the quantity of water injected at the end of the transient. However, the numerical results for the pressure show that for low values of CORFZ the calculated pressure is higher than the experimental data. In the simulation this can be explained qualitatively by the fact that higher pressure drop coefficients result in lower water mass injected and thus a lower impact of the flashing of the water on the pressurization of the reaction vessel. Hence, as intermediate conclusion, neglecting the chemical reaction, the parametric analysis presented two contrasting results: for the values of CORFZ for which the water injected is within the range of the experimental values, the pressure evolution inside the S1B vessel does not show a good agreement. Therefore, it is necessary to evaluate the effect of the chemical reaction on the pressure transient.

The first step to perform the parametric study on FKCR is to understand how the water injected change with the FKCR, indeed the presence of the chemical reaction influence the condition of the S1B and thus the water injected during the injection phase. It is necessary to verify if using a CORFZ which could be considered acceptable from the analysis of the pressure drop coefficient would provide unacceptable results of water mass injected.

For the analysis a CORFZ of 0.01 is used; the water mass injected, calculated integrating the water mass flowrate entering the S1B, is shown in Fig. 4. It is also interesting to see that in the time interval between 0.2 and 0.4 s the mass flowrate is completely unaffected by the FKCR. This could be explained by the fact that in this interval there is a

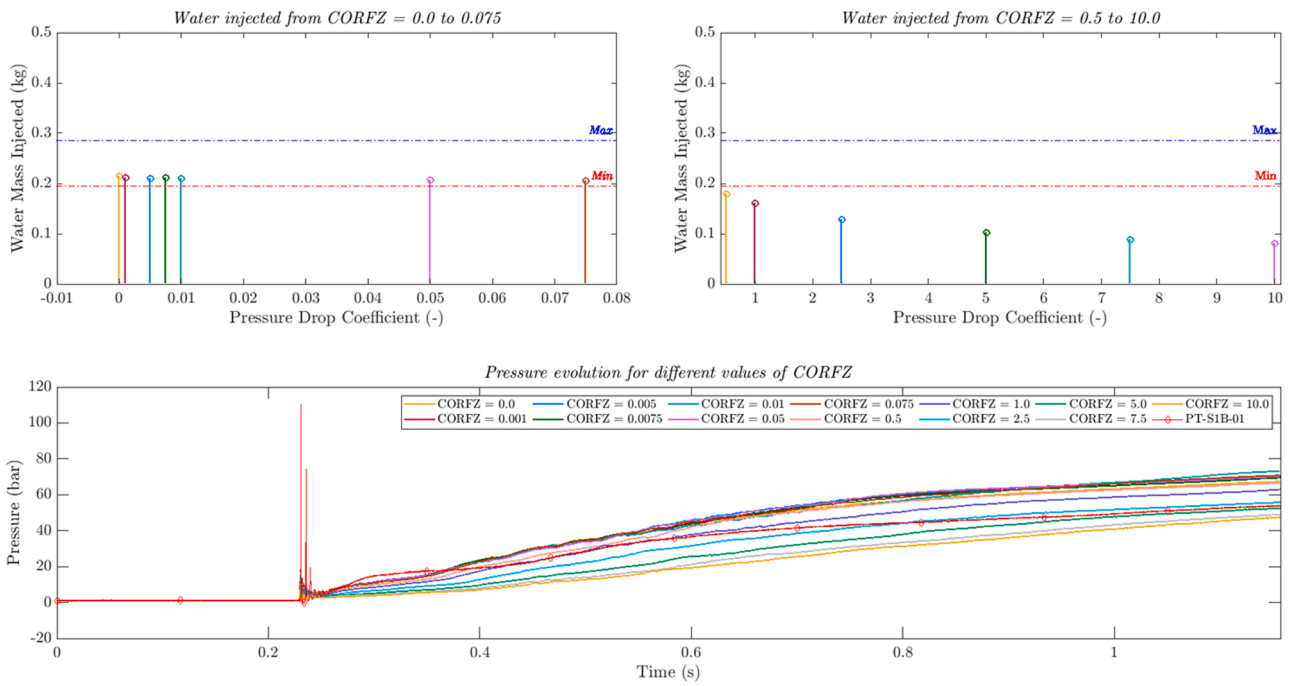

Fig. 3. Water injected and Pressure in S1B CORFZ study.

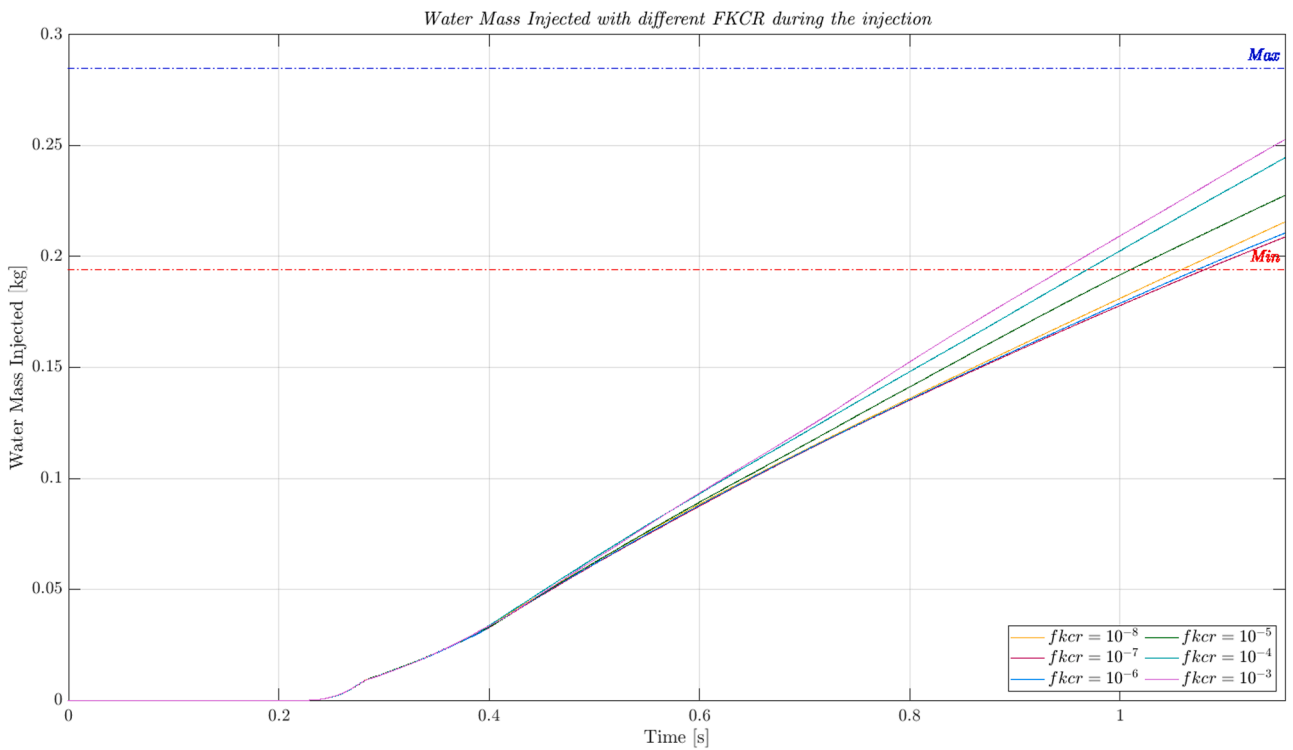

Fig. 4. Water Mass injected FKCR parametric study.

choked flow regime, due to the very big difference in pressure between the S1B and the injection line. After this regime, the water injected is affected by the pressure in the S1B and it is possible to see that lower FKCR results in lower mass entering the S1B, except for $FKCR = 10^{-8}$ which resulted in higher water injected than the case with $FKCR = 10^{-6}$ and $FKCR = 10^{-7}$. It is also important to underline that the variation of water is still inside the acceptable range of water injected inside the S1B, obtained from the experimental data.

The pressure transient inside the reaction vessel is the key parameter to understand the interaction between water and lithium-lead. The transient evolution can be seen in Fig. 5, which is divided into two main time intervals, the injection phase and the post-injection phase. The injection phase lasts from the cap rupture to the closure of the injection valve (from around 0.2 s to 1.2 s), whilst the post-injection phase last from the closure of the injection valve to a relative stabilization of the pressure (from around 1.2 s to 5 s).

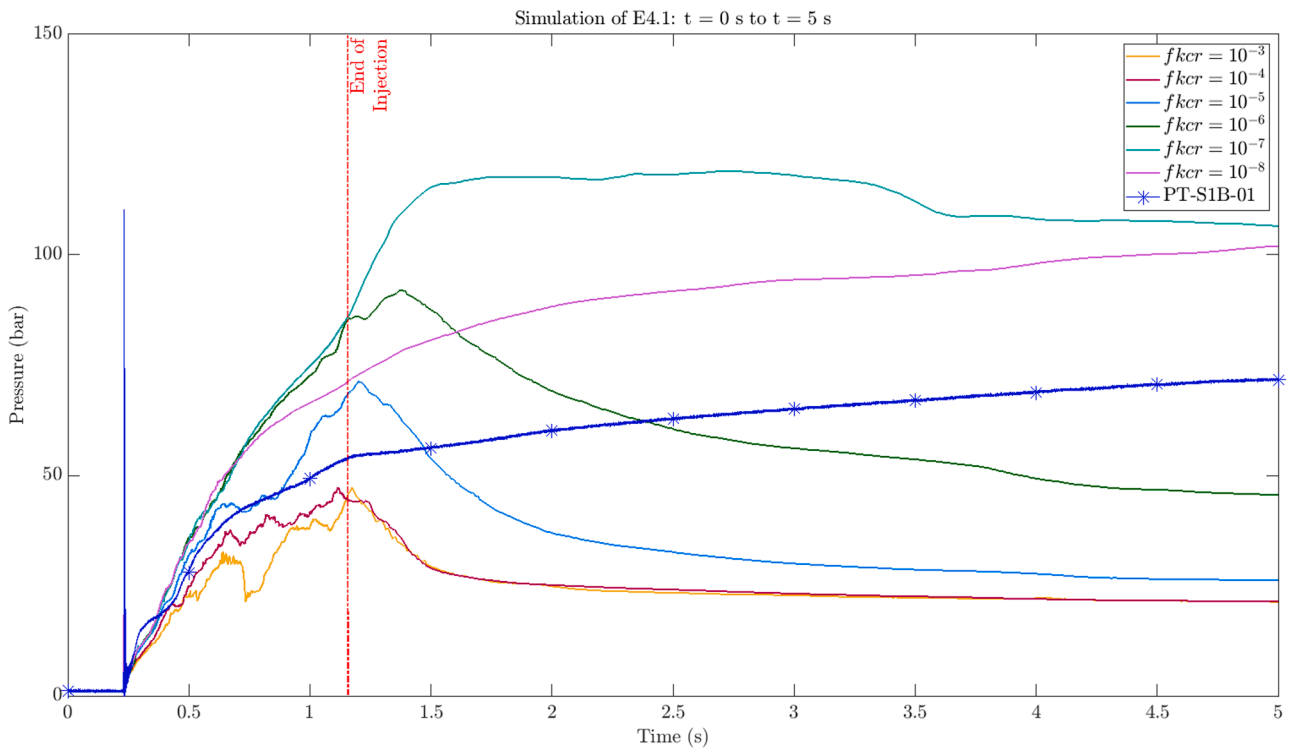

Fig. 5. Pressure evolution FKCR parametric study.

The injection phase shows that the pressure evolution is greatly influenced by the chemical reaction rate. Indeed, the pressurization is due to the expansion of liquid water flashing into steam and the chemical exothermic reaction between the liquid and vapour water and lithium-lead. During the injection phase the pressurization of the S1B ('PT-S1B-01', blue starred line in Fig. 5) is reproduced with good

agreement by the numerical simulation for higher values of FKCR, precisely for FKCR between 10^{-4} and 10^{-5} . Although the chemical reaction is exothermic, the increase of the pressure is mainly driven by the thermodynamic interaction of water and the expansion of liquid water during this phase, the chemical reaction obstructs the thermodynamic interaction. The generation of Hydrogen and Lead might screen the

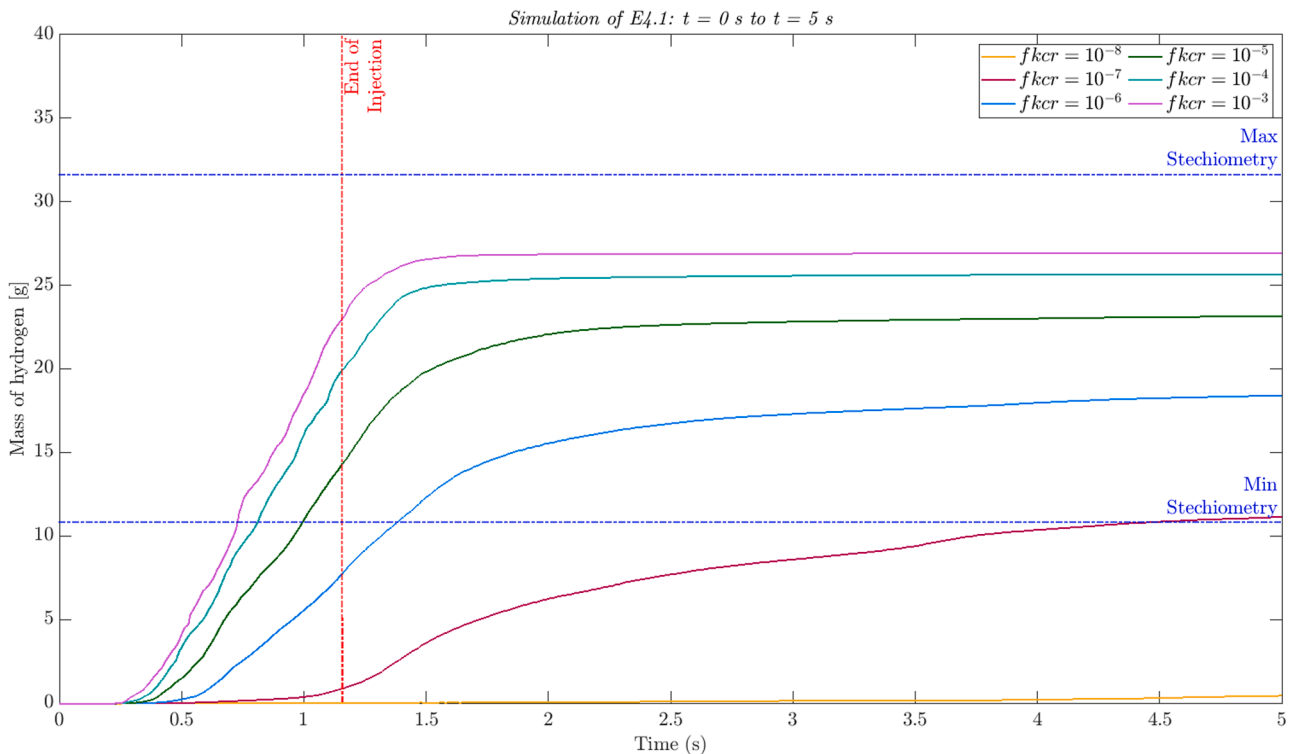

Fig. 6. Hydrogen Mass produced FKCR parametric study.

contact between Lithium-Lead and Water reducing the thermodynamic interaction between the two fluids and thus the pressurization of the system. Another factor might be that with high reaction rate coefficients liquid water has less time to expand into vapour before being consumed by the reaction, contributing less to the pressurization of the system.

The post-injection phase is instead characterized by a lower reaction rate, indeed the higher FKCR that are in good agreement with the pressurization curve during the injection, do not reproduce very well the pressurization after the injection. The difference in the chemical reaction rate between the two phases of the test is due to the presence of turbulence. Indeed, the turbulence increases the mixing between the two fluids increasing the surface contact area between the two reactants. It is also possible that the turbulence increases the capabilities of Lithium to diffuse to the Lead-Lithium free surface, leading to an increase of lithium available for the chemical reaction, indeed different modelling activities were performed in the past to try to model the diffusion of Lithium inside the Liquid Metal pool. [15,16] This factor with also the equilibrium constant of the reactants determines the chemical kinetics of the Lithium-Lead/water interactions which is still under investigation and a possible implementation is foreseen in future works.

In Fig. 6 is possible to see the hydrogen mass produced by the chemical reaction which is one of the main safety concerns of the WCLL-BB concept. It is possible to see that for values of FKCR of 10^{-4} and 10^{-5} the hydrogen produced is in line with the stoichiometric values of the reaction but also with the measured experimental value. This is in line with the validation process of SIMMER-III and SIMMER-IV codes performed during various numerical activities.

The water content inside the S1B is shown in Fig. 7. The discrepancy between the values of the injected water and the content of water inside the S1B is due to the chemical reaction, which being faster for higher FKCR consumes more water during the same time interval. It is possible to see that for $FKCR = 10^{-8}$ the water content is very near to the values shown in Fig. 4, this means that the water for those values of FKCR is almost not reacting during the simulation. Further proof is the negligible amount of Hydrogen mass obtained using the same FKCR, as shown in Fig. 6.

The vapour phase mass content inside the S1B, shown in Fig. 8, shows the importance of the vaporization and the combination of various factors on the pressure evolution of the system during the interaction. Indeed, for higher values of FKCR the vapour phase mass is lower since the liquid water available for the phase transition is lower; an exception is $FKCR = 10^{-7}$ where the liquid water available for the phase transition is quite high being the chemical reaction exothermic and the reaction rate higher than the case with $FKCR = 10^{-8}$, the overall vaporization is higher. Considering also Fig. 5, it is possible to see that for higher FKCR the low values of water available for the phase transition greatly influence the pressurization. Indeed, for high values of FKCR the pressurization is lower whereas for low values of FKCR the pressurization is higher and the exothermic reaction combined with the availability of liquid water results in higher values of pressurization with respect to the case where the chemical reaction is almost negligible ($FKCR = 10^{-8}$).

5. Conclusions

A numerical analysis of LIFUS5/Mod3 test E4.1 was carried out during this study. The analysis is focused on the parametric study of two different coefficients used in SIMMER-III code. The pressure drop coefficient of the injector device is very important to determine the quantity of water injected inside the S1B, which is the main parameter leading to the pressurization of the system. The parametric study shows that for low values of the pressure drop coefficient the water injected is in the acceptable range, meaning that is in the range of the experimental values. The parametric study on the chemical reaction rate shows that during the injection the pressurization is reproduced with a high occurrence of the chemical reaction between the two fluids.

The FKCR parametric study also underlines the importance of chemical kinetics on the evolution of the pressure transient. Indeed, it has a relevant impact on the pressurization of the system. This is due to the combination of the various factor that leads to the pressurization, governed by the thermodynamic and chemical interaction of Lead-Lithium and water. In fact, the pressurization is due to a combination

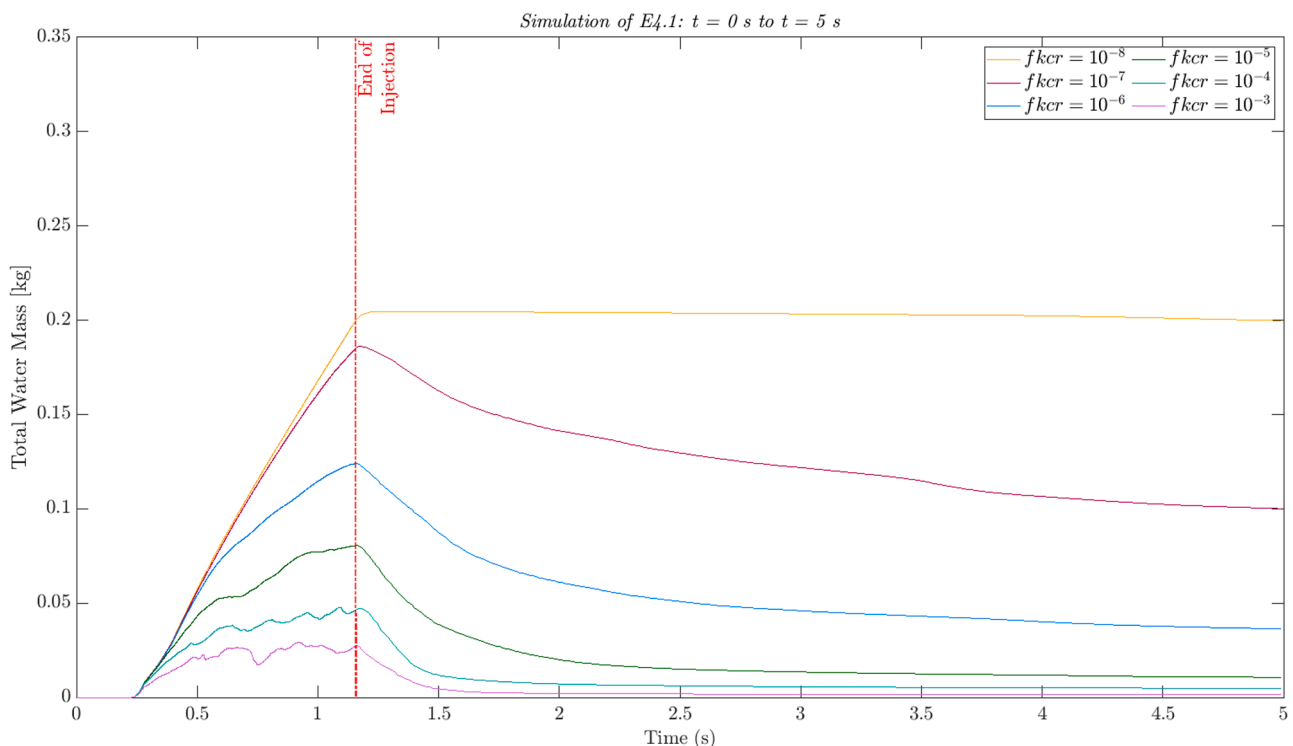

Fig. 7. Water(liquid plus vapour) inside the S1B FKCR parametric study.

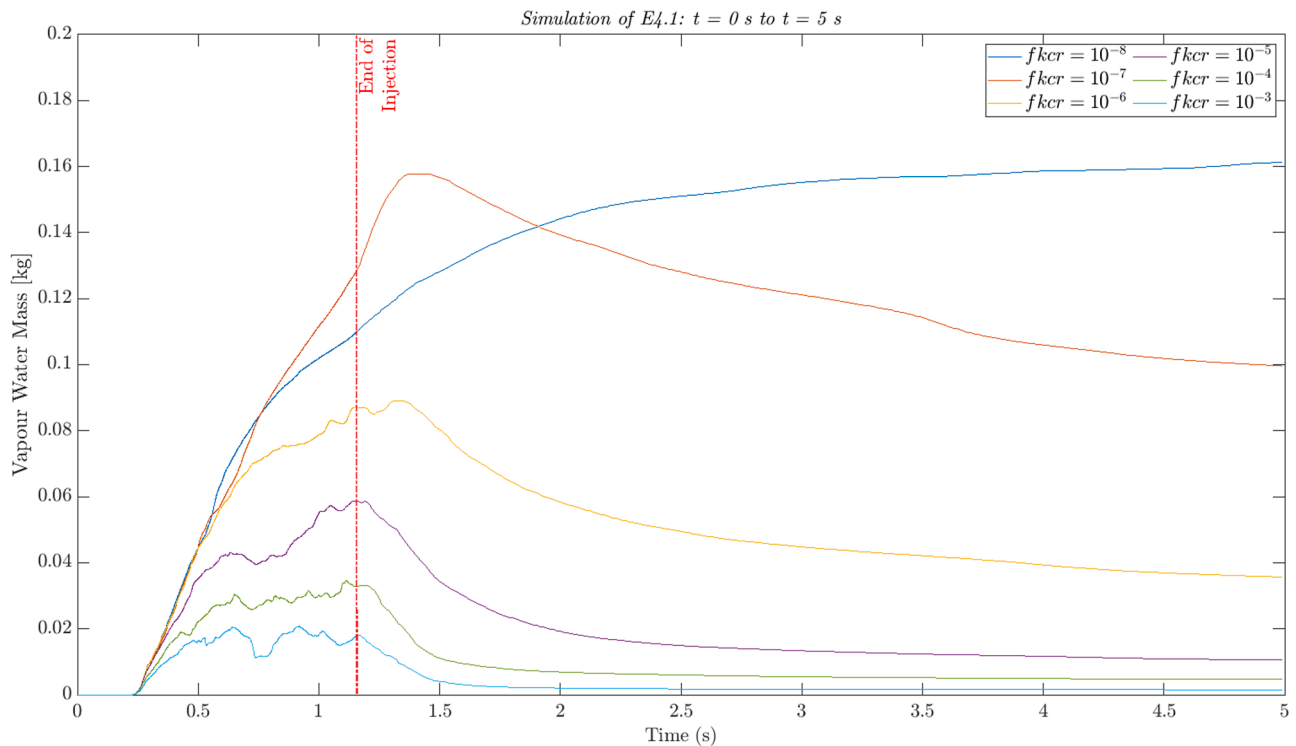

Fig. 8. Vapour Mass content inside S1B FKCR parametric study.

of the liquid water flashing, the chemical exothermic reaction with liquid phase water and with vapour phase water. The chemical reaction rate is thought to be beneficial during the first phase of the transient for the pressure evolution, indeed the production of hydrogen might reduce the contact area between the two fluids, reducing in this way the thermodynamic interaction but also self-limiting the chemical reaction; furthermore, a reduction in liquid water availability reduces the possibility of liquid water expansion. Despite the important work carried on for the adaptation of the SIMMER-III code to the Lithium-Lead/water interaction a further investigation on the chemical kinetics seems important to correctly evaluate the effect of chemical reaction on the overall response of a plant in the case of in-box LOCA. Nonetheless, it is possible to see, through the parametric study, the indication of a higher chemical reaction rate during the injection of water which is related to the higher turbulence in the system during the injection, which leads to a higher interfacial area between the two fluids and a plausible increase of lithium diffusion to the Lithium-Lead free surface. A further investigation is foreseen on the SIMMER-III interfacial area calculations, governed by the flow regime of the two fluids to understand the influence of turbulence in these calculations. Furthermore, also an additional investigation on possible chemical kinetics models that could be used inside SIMMER-III to represent the chemical reaction rate.

Declaration of Competing Interest

The authors declare that they have no known competing financial interests or personal relationships that could have appeared to influence the work reported in this paper.

Data availability

The data that has been used is confidential.

Acknowledgement

This work has been carried out within the framework of the EUROfusion Consortium, funded by the European Union via the Euratom Research and Training Programme (Grant Agreement No 101052200—EUROfusion). Views and opinions expressed are however those of the author(s) only and do not necessarily reflect those of the European Union or the European Commission. Neither the European Union nor the European Commission can be held responsible for them.

References

- [1] A. Del Nevo, P. Arena, G. Caruso, P. Chiovaro, P.A. Di Maio, M. Eboli, F. Edemetti, N. Forgiione, R. Forte, A. Froio, F. Giannetti, G. Di Gironimo, K. Jiang, S. Liu, F. Moro, R. Mozzillo, L. Savoldi, A. Tarallo, M. Tarantino, A. Tassone, M. Utili, R. Villari, R. Zanino, E. Martelli, Recent progress in developing a feasible and integrated conceptual design of the WCLL BB in EUROfusion project, *Fusion Eng. Des.* 146 (2019) 1805–1809. September.
- [2] G. Caruso, et al., DEMO – The main achievements of the Pre – Concept phase of the safety and environmental work package and the development of the GSSR, *Fusion Eng. Des.* 176 (2022), 113025. Mar.
- [3] G. Federici, L. Boccaccini, F. Cismondi, M. Gasparotto, Y. Poitevin, I. Ricapito, An overview of the EU breeding blanket design strategy as an integral part of the DEMO design effort, *Fusion Eng. Des.* 141 (2019) 30–42. April.
- [4] L. Boccaccini, et al., Status of maturation of critical technologies and systems design: breeding blanket, *Fusion Eng. Des.* 179 (2022), 113116.
- [5] R. Mozzillo, M. Utili, A. Venturini, A. Tincani, C. Gliss, Integration of LiPb loops for WCLL BB of European DEMO, *Fusion Eng. Des.* 167 (2021), 112379. Jun.
- [6] J. Aubert, G. Aiello, D. Alonso, T. Batal, R. Bouillon, S. Burles, B. Cantone, F. Cismondi, A. Del Nevo, L. Maqueda, A. Morin, E. Rodríguez, F. Rueda, M. Soldaini, J. Vallory, Design and preliminary analyses of the new water cooled Lithium Lead TBM for ITER Fusion Engineering and Design, vol. 160, Article 111921, Nov. 2020.
- [7] M. Eboli, N. Forgiione, A. Del Nevo, Implementation of the chemical PbLi/water reaction in the SIMMER code, *Fusion Eng. Des.* (2016) 468–473, 109–111 November.
- [8] M. Eboli, F. Galleni, N. Forgiione, N. Badodi, A. Cammi, A. Del Nevo, Experimental and numerical results of LIFUS5/Mod3 Series E test on in-box LOCA transient for WCLL-BB, *Energies* 14 (2021) 8527.
- [9] Marica Eboli, Samad Khani Moghanaki, Daniele Martelli, Nicola Forgiione, Maria Teresa Porfiri, Alessandro Del Nevo, experimental activities for in-box LOCA of WCLL BB in LIFUS5/Mod3 facility, *Fusion Eng. Des.* 146 (2019) 914–919. Part A.
- [10] M. Eboli, R.M. Crugnola, A. Cammi, S. Khani, N. Forgiione, A. Del Nevo, Test series D experimental results for SIMMER code validation of WCLL BB in-box LOCA in LIFUS5/Mod3 facility, *Fusion Eng. Des.* 156 (2020), 111582. Jul.

- [11] Francesco Galleni, Samad Moghanaki, Marica Eboli, Alessandro Del Nevo, Sandro Paci, Riccardo Ciolini, Rosa Lo Frano, Nicola Forgone, RELAP5/SIMMER-III code coupling development for PbLi-water interaction, *Fusion Eng. Des.* 153 (2020).
- [12] Marica Eboli, Nicola Forgone, Alessandro Del Nevo, Assessment of SIMMER-III code in predicting water cooled lithium lead breeding blanket “in-box-loss of coolant accident”, *Fusion Eng. Des.* 163 (2021).
- [13] A. Pucciarelli a, A. Toti, D. Castelliti, F. Belloni, K. Van Tichelen, M. Moscardini, F. Galleni, N. Forgone, Coupled system thermal hydraulics/CFD models: general guidelines and applications to heavy liquid metals, *Ann. Nucl. Energy* 153 (2021). VolumeApril.
- [14] Bruno Gonfiotti, Samad Khani Moghanaki, Marica Eboli, Gianluca Barone, Alessandro Del Nevo, Daniele Martelli, Development of a SIMMER\RELAP5 coupling tool, *Fusion Eng. Des.* 146 Part B (2019) 1993–1997.
- [15] Yachimiak, E., Kazimi, M.S. Safety analysis of liquid lithium-lead breeders in fusion reactor geometries, MIT Plasma Science and Fusion Center, (1984).
- [16] Herzog, J.P., Corradini, M.L. Lithium-Lead/Water Reaction Experiments and Analysis, *Fusion Technology*, (1989).