



23 European Conference on Fracture – ECF23

# Effects of coating on the fatigue endurance of FDM lattice structures

A. Chiocca\*, F. Tamburrino\*\*, F. Frendo, A. Paoli

*Department of Civil and Industrial Engineering, Largo Lucio Lazzarino 2, Pisa 56123, Italy*

## Abstract

Additive Manufacturing techniques, such as Fused Deposition Modeling (FDM), are widely used to produce lattice structures with complex unit cell geometries. These structures can be designed to meet specific requirements in a wide range of application fields, ranging from biomedical to mechanical sectors. The mechanical behavior of these structures is often impaired by a low surface quality. However, the mechanical strength of polymer lattice structures can be significantly improved with the use of post-processing treatments. Coating post-processing is one of the treatments that showed the best results. Nevertheless, research interests are often targeted at studying the static mechanical properties rather than the fatigue behavior of polymer components. In this work, the effect of a polymeric coating on the fatigue life of Polylactic acid (PLA) lattice structures, produced by FDM, was investigated. Specimens have been designed to enable the application of both tensile and compressive loads. Preliminary tensile tests were carried out to assess the static strength of the specimen before the fatigue tests. Experimental fatigue tests were performed with varying testing frequencies and displacements. The results evidenced differences in the behavior of coated and non-coated components when subjected to different testing frequencies and loading conditions. The polymeric coating produced an increase in fatigue endurance across different testing frequencies over a particular displacement range.

© 2022 The Authors. Published by Elsevier B.V.

This is an open access article under the CC BY-NC-ND license (<https://creativecommons.org/licenses/by-nc-nd/4.0>)

Peer-review under responsibility of the scientific committee of the 23 European Conference on Fracture – ECF23

*Keywords:* Additive manufacturing; PLA; FDM; fatigue; coating; lattice structure

## 1. Introduction

Polymer lattice structures produced by Additive Manufacturing (AM) technologies are increasingly studied and applied when looking for lightweight design, vibration isolation, energy absorption and good strength-to-weight and high surface-to-volume ratios (Elmadih et al. (2019); Sun et al. (2021)). Several AM technologies can be used to fabricate polymer lattice structures. However, among these, Material Extrusion (ME), also known as Fused Deposition Modeling (FDM), is the most widespread and low-cost and it allows the use of a wide range of non-reinforced and reinforced thermoplastic polymers. Nevertheless, lattice structures are generally made of thin elements and their manufacturing is high-demanding in terms of quality and resolution. The presence of poor surface characteristics as-

\* Corresponding author. Tel.: +39-050-2218011.

\*\* Corresponding author. Tel.: +39-050-2218015.

*E-mail address:* andrea.chiocca@unipi.it, francesco.tamburrino@unipi.it

sociated with the layer stratification typical of AM can significantly and negatively affect the mechanical performance of the manufactured lattice structures (Park and Rosen (2016); Ngo et al. (2018); Wickramasinghe et al. (2020)). The surface characteristics of lattice structures can be improved through the optimization of the printing parameters. More significant results, however, can be obtained through post-processing treatments (Chohan and Singh (2017); Tamburrino et al. (2021)). Because of the high geometrical complexity of these structures, not all post-processing treatments are suitable. At this regard, coating treatments, which are based on the application of a thin film of a coating product on the external surface of the lattice structure, seems to be those promising the best results. The obtained effect is a greater homogeneity of the surfaces, a reduction in the number of defects and a lower roughness. In the last few years, some studies have been carried out with the aim at evaluating the coating effect on the static mechanical properties of AM lattice structures (Barone et al. (2022); Gümruk et al. (2018)). However, the presence of higher quality surfaces with fewer defects could have a more significant impact when cyclic loads are applied (Savio et al. (2019)). There is a lack of studies in the literature that investigate the effects of coating on the fatigue endurance of AM lattice structures.

In the present study, a coating treatment was applied to a lattice structure specimen based on FCC unit cells geometry, 3D printed using PLA (Polylactic acid) material via FDM process. The specimen was designed to be suitable for both tensile and compression loading conditions, through the introduction of suitable ends that can be clamped into the hydraulic test machine. Preliminary static tests were performed to assess the variation of static strength and elongations in presence of the coating. Subsequently, fully reversed (i.e.,  $R=-1$ ) fatigue tests were performed under displacement control. Tests were conducted at two different frequencies:  $f = 3$  Hz and  $f = 20$  Hz. The specimens' surface temperature was monitored by a thermal-imaging camera to monitor possible thermal runaway effects or excessive increases in the material temperature.

## 2. Materials and methods

In the present study, a material extrusion additive manufacturing process was used, specifically the Fusion Deposition Modeling (FDM). As shown in Figure 1a, a Creality CR-10 S5, equipped with a nozzle with a diameter of 0.4 mm, was adopted as 3D printing machine with the following main process parameters: layer height 0.2 mm, printing speed  $50 \text{ mm s}^{-1}$  and extrusion temperature of  $200^\circ$ . The Ultimaker Cura software (Figure 1b) was used to pre-process the CAD model of the FCC lattice structure and to set the process parameters. The final printed FCC lattice structure is shown in Figure 1c.

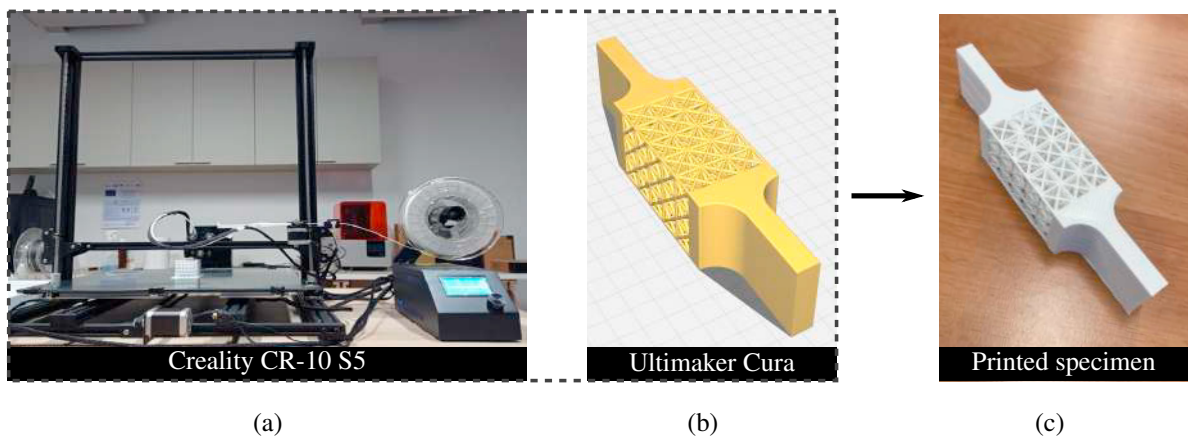

Fig. 1. 3D printing equipment (a), software used for 3D printing pre-processing (b) and PLA specimen after 3D printing (c)

A redesign of the standard specimen geometry made for compressive tests (Barone et al. (2022)) was necessary to be suitable for tensile tests. A specific geometry is presented in Figure 2. The nominal test section has dimensions of  $35.6 \times 35.6 \times 57 \text{ mm}^3$  and consists of  $3 \times 3 \times 5$  FCC unit cells with a dimension of  $12.8 \times 12.8 \times 12.8 \text{ mm}^3$ . The testing area is represented by the central region of the specimen, while the outer regions have the only purpose to clamp the

component on the test machine. The material used within this study is a PLA filament produced by Ultimaker with the following material properties (i.e. values retrieved from catalogue [Ultimaker \(2018\)](#)): 49.5 MPa of tensile stress at yield, 2346 MPa of Young's modulus and 5.2% of elongation at break.

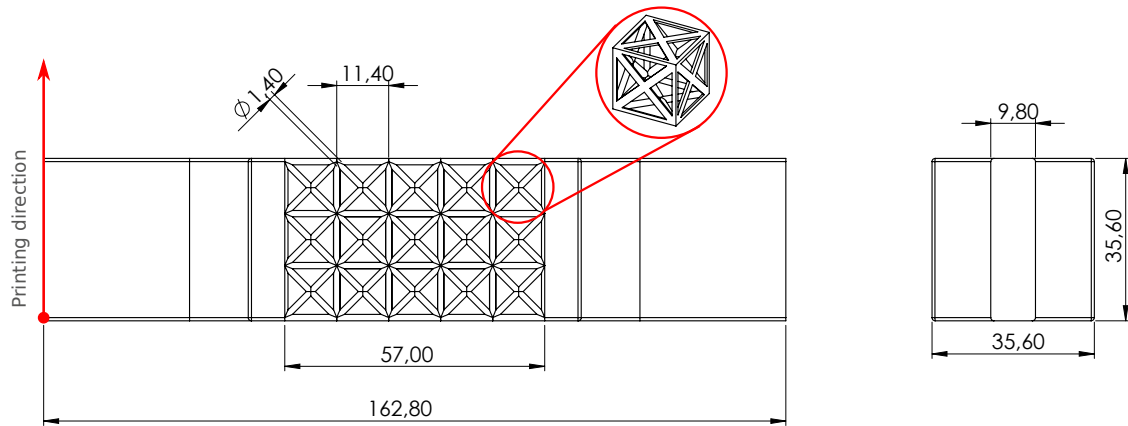

Fig. 2. Technical drawing of specimen used for static and fatigue tensile and compression tests

### 2.1. Coating process

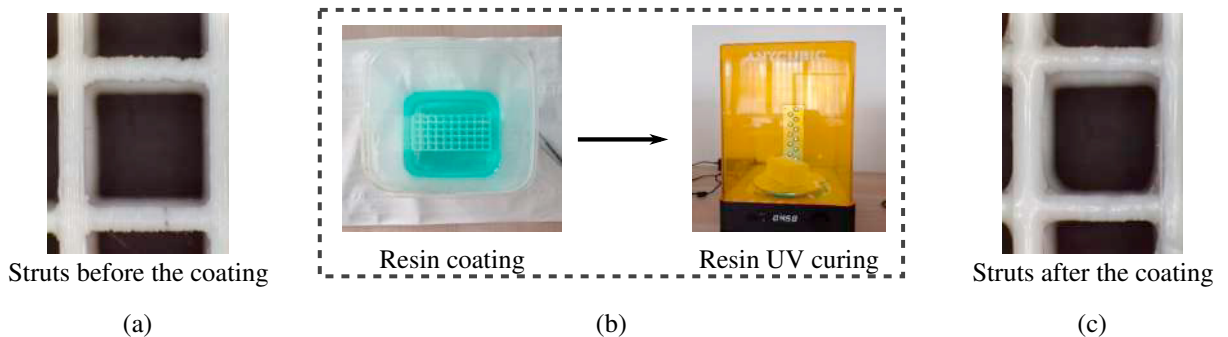

Fig. 3. Struts before the coating application (a), coating resin application process (b) and struts after the coating application (c)

A coating process was carried out across the central test area of the specimen. The coating resin is a UV DLP Poliglass with material properties after curing similar to those of the base material. The material properties obtained from the seller catalogue [Photocentric \(2018\)](#) are 40 MPa of tensile strength, 2100 MPa of Young's modulus and 4% of elongation at break. The process is carried out manually and divided into three steps:

- immersion of the specimen in a tank containing photoresin for 5 min;
- specimen draining to remove the extra resin;
- curing of the coated resin using Wash & Cure Machine 2.0 (Anycubic Company); the curing procedure consists of UV-curing for 10 min per side at a wavelength of 405 nm, for a total amount of 60 min.

The coating process is presented in Figure 3, together with a close-up of the specimen struts before and after the coating process. It is clearly visible from Figure 3a the surface roughness (i.e., layer-by-layer appearance) due to the printing process and the more uniform surface appearance after the application of the coating resin (Figure 3c).

## 2.2. Static and fatigue tests

Tensile and fatigue tests were carried out at room temperature on a MTS testing machine with a load cell of 25 kN, as shown in Figure 4. Displacement controlled tensile tests with a cross-head speed of  $0.05 \text{ m s}^{-1}$  were carried out while measuring both force and displacement resulting from the machine's embedded sensors. In the case of the fatigue tests, the same specimen layout and the same outputs were used. The tests were performed under displacement control at different frequencies (i.e., 3 Hz and 20 Hz) for fully reversed load conditions (i.e.,  $R = -1$ ).

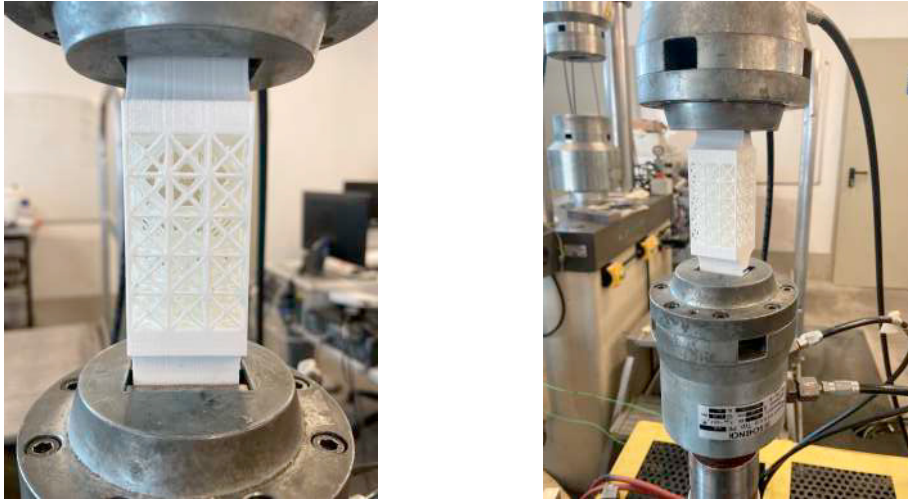

Fig. 4. Installation layout of the lattice structure specimen on the testing machine for static and fatigue tests

## 3. Results and discussion

This section provides results for static and fatigue tests carried out on “As-Printed” (before coating) and “Coated” (after coating) specimens.

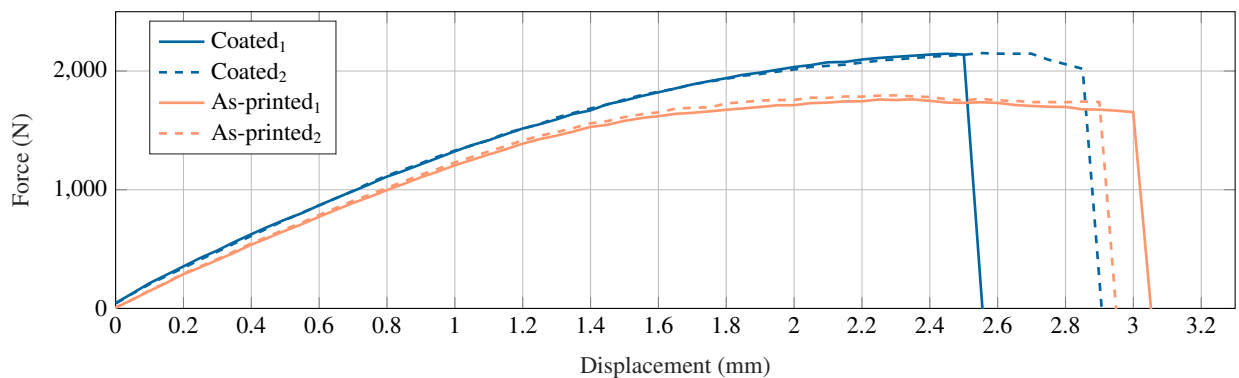

Fig. 5. Force vs. displacement data of Coated and As-Printed specimens tested under displacement control tensile tests

### 3.1. Static test

Figure 5 shows the results of four static tests, two for the Coated specimens and two for the As-Printed specimens. Since it is challenging to define local parameters and stress conditions for lattice geometries, the plot presents data as force vs. displacement. For the sake of clarity, it was therefore considered appropriate to present results through global parameters, although this leads to a full dependency between results, geometry and material used. Both force

and displacement were measured directly using the machine’s sensors. In particular, the initial displacement was zeroed at the same clamps distance for all tested specimens in order to obtain comparable data (i.e. referred to the same initial length).

Data evidence how a greater resistance was achieved through the Coated specimens, although they presented a minor elongation at break with respect to the As-Printed ones. The tests on Coated specimens showed an average maximum force value of 2100 N and an average elongation at break of 2.65 mm, while the As-Printed ones showed an average maximum force of 1700 N and an average elongation at break of 2.9 mm.

### 3.2. Fatigue test

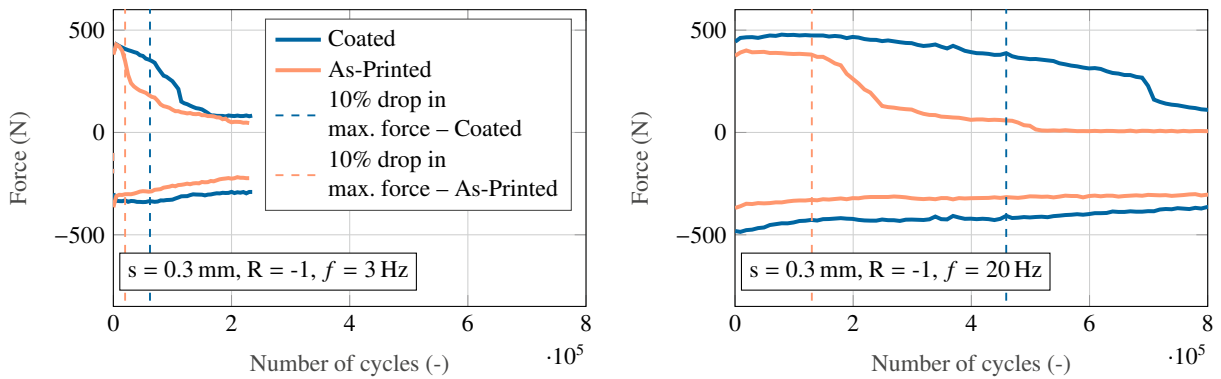

Fig. 6. Force vs. number of cycles data of Coated and As-Printed specimens tested under displacement control fatigue tests under different frequencies

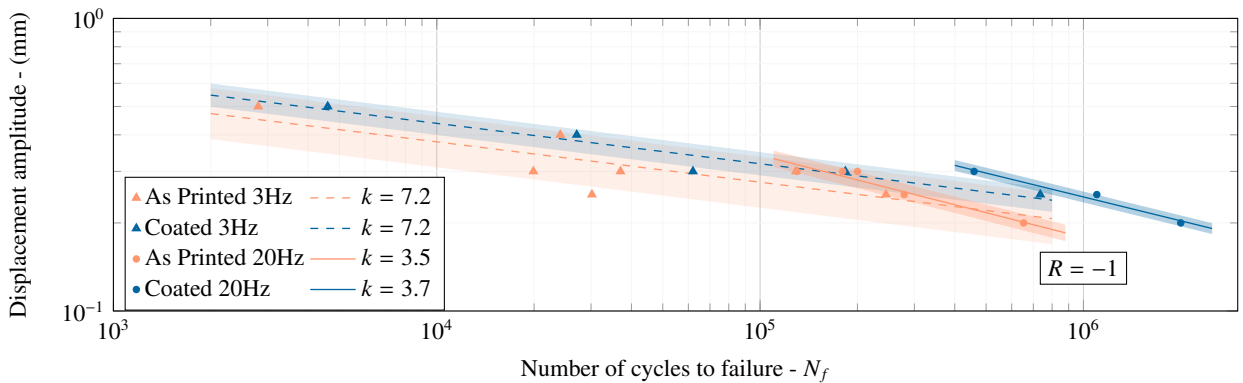

Fig. 7. Displacement amplitude vs. number of cycles to failure for Coated and As-Printed specimens tested under displacement control fatigue tests at different frequencies

From a fatigue perspective, a common behavior of the force over the number of cycles has been identified. Figure 6 presents the measured force over the number of cycles during the fatigue tests of Coated and As-Printed specimens using two different frequencies,  $f = 3$  Hz and  $f = 20$  Hz, for a fully reversed loading condition. It can be noted how in all cases, three main phases in the force response can be identified. In the first one, the force increases as the test time increases, normally this phase is rather short compared to the total time of test. The second phase is characterized by a slight force decrease with the increasing test time. The final phase is instead characterized by a sudden drop in force, identifiable by a large-scale failure of the specimen. The number of cycles to failures have been defined as the number of cycles that yield to a 10% drop in the maximum force reached during the test. In Figure 6 the number of cycles to

failure have been identified by different colored dashed lines depending on the specimen post-processing conditions. Two main outcomes are observable from the results of Figure 6. The first one is that by increasing the test frequency the fatigue endurance increases for both the Coated and As-Printed specimens, as also observed by Eftekhari and Fatemi (2016). This first behavior can be explained by the time in which the specimen remains subjected to a condition of maximum stress on equal displacements. At lower frequencies, indeed, the material is subjected for a greater time at higher stress values (Kocjan et al. (2022)). This can be stated if the specimen maintains the same temperature during testing, condition that was respected for the reported tests. The specimen surface temperature, indeed, was monitored using a thermal-imaging camera and only a maximum variation of 0.8 °C was detected between specimens tested at the two different frequencies.

The second outcome shows how the coating post-processing (i.e., for the same test frequency) causes an increase in the fatigue resistance. Since one of the main fatigue drivers is surface roughness, the surface smoothing provided by the thin film of coating may be considered one of the factor in the enhancement of the component fatigue endurance. The fatigue test results have been summarized in Figure 7 by means of a displacement amplitude vs. number of cycles to failure diagram. The 50% probability-of-failure curves and the colored bands identifying the bounds of 10% and 90% probability-of-failure were provided besides the experimental data. The results evidence how the curve slope remains unchanged under the same test frequency for both Coated and As-Printed specimens while the fatigue strength shifts, with an increase for Coated specimens. On the contrary, the curve slope varies considerably from  $k = 7.2$  to  $k = 3.6$  as the test frequency varies from  $f = 3$  Hz to  $f = 20$  Hz.

It is worth noting that another factor that may be relevant in differentiating the behavior between As-Printed and Coated specimens can be the increased cross-sectional area of the struts after the coating process. However, as accurate measurements are not yet available, it is not possible to determine the extent of this effect. This aspect will be covered as part of future works.

#### 4. Conclusion

In this paper, static and fatigue strength data of coated and as printed PLA-FCC lattice structures were presented. A specific specimen geometry was introduced to enable the application of both tensile and compressive loads. The steps necessary to carry out the coating process were illustrated and discussed. Finally, static and fatigue results were reported, the latter at two different testing frequencies. The data evidenced how the presence of a surface coating increased both the static and fatigue strength characteristics of the specimen. Statically, a 21% increment in maximum strength occurred, while the maximum elongation decreased by 9% in the presence of the coating. During fatigue tests, the coating process enhanced the fatigue strength for both test frequencies by 14% and 18% for  $f = 3$  Hz and  $f = 20$  Hz, respectively. Clearly, more specimens should be tested to achieve higher results consistency. However, these preliminary results are interesting and encouraging. Further steps should consider the study of the coating thickness variation between the different specimens and the evaluation of numerical models to gain more insights into the fracture behavior of the component.

#### Acknowledgement

This paper is supported by the Ministry of University and Research (MUR) as part of the PON 2014-2020 “Research and Innovation” resources – Green Action - DM MUR 1062/2021 - Title of the Research: Development and conversion of automotive devices towards sustainability: the decarbonisation of vehicles and new uses of thermo-hydraulic systems.

#### References

- Barone, S., Neri, P., Paoli, A., Razionale, A.V., Tamburrino, F., 2022. Effects of Coating Post-processing on the Compressive Properties of Strut-and-Node-Based FDM Lattice Structures, in: Lecture Notes in Mechanical Engineering, Springer Science and Business Media Deutschland GmbH, pp. 442–450. doi:10.1007/978-3-030-91234-5\_45.
- Chohan, J.S., Singh, R., 2017. Pre and post processing techniques to improve surface characteristics of FDM parts: A state of art review and future applications. doi:10.1108/RPJ-05-2015-0059.

- Eftekhari, M., Fatemi, A., 2016. On the strengthening effect of increasing cycling frequency on fatigue behavior of some polymers and their composites: Experiments and modeling. *International Journal of Fatigue* 87, 153–166. doi:[10.1016/j.ijfatigue.2016.01.014](https://doi.org/10.1016/j.ijfatigue.2016.01.014).
- Elmadih, W., Syam, W.P., Maskery, I., Chronopoulos, D., Leach, R., 2019. Mechanical vibration bandgaps in surface-based lattices. *Additive Manufacturing* 25, 421–429. doi:[10.1016/j.addma.2018.11.011](https://doi.org/10.1016/j.addma.2018.11.011).
- Gümriük, R., UŞUN, A., Mines, R., 2018. Enhancement of the Mechanical Performance of Stainless Steel Micro Lattice Structures Using Electroless Plated Nickel Coatings, in: *Proceedings 2018*, Vol. 2, Page 494, Multidisciplinary Digital Publishing Institute. p. 494. doi:[10.3390/ices18-05403](https://doi.org/10.3390/ices18-05403).
- Kocjan, T., Nagode, M., Klemenc, J., Oman, S., 2022. Prediction of actual fatigue test temperature and isothermal fatigue life curves for non-crystallising rubber under fully relaxing uni-axial loading conditions. *International Journal of Fatigue* 157, 106622. doi:[10.1016/j.ijfatigue.2021.106622](https://doi.org/10.1016/j.ijfatigue.2021.106622).
- Ngo, T.D., Kashani, A., Imbalzano, G., Nguyen, K.T., Hui, D., 2018. Additive manufacturing (3D printing): A review of materials, methods, applications and challenges. doi:[10.1016/j.compositesb.2018.02.012](https://doi.org/10.1016/j.compositesb.2018.02.012).
- Park, S.i., Rosen, D.W., 2016. Quantifying effects of material extrusion additive manufacturing process on mechanical properties of lattice structures using as-fabricated voxel modeling. *Additive Manufacturing* 12, 265–273. doi:[10.1016/j.addma.2016.05.006](https://doi.org/10.1016/j.addma.2016.05.006).
- Photocentric, 2018. Technicaldata sheet UV DLP Poliglass.
- Savio, G., Rosso, S., Curtarello, A., Meneghello, R., Concheri, G., 2019. Implications of modeling approaches on the fatigue behavior of cellular solids. *Additive Manufacturing* 25, 50–58. doi:[10.1016/j.addma.2018.10.047](https://doi.org/10.1016/j.addma.2018.10.047).
- Sun, Z.P., Guo, Y.B., Shim, V.P., 2021. Characterisation and modeling of additively-manufactured polymeric hybrid lattice structures for energy absorption. *International Journal of Mechanical Sciences* 191, 106101. doi:[10.1016/j.ijmecsci.2020.106101](https://doi.org/10.1016/j.ijmecsci.2020.106101).
- Tamburrino, F., Barone, S., Paoli, A., Razionale, A.V., 2021. Post-processing treatments to enhance additively manufactured polymeric parts: a review. doi:[10.1080/17452759.2021.1917039](https://doi.org/10.1080/17452759.2021.1917039).
- Ultimaker, 2018. Technicaldata sheet PLA.
- Wickramasinghe, S., Do, T., Tran, P., 2020. FDM-Based 3D printing of polymer and associated composite: A review on mechanical properties, defects and treatments. doi:[10.3390/polym12071529](https://doi.org/10.3390/polym12071529).