

**Master of Science in Sustainable Energy Technology**

SELECT, Environmental Pathways for Sustainable Energy Systems  
Department of Industrial Engineering & Innovation Sciences  
Research Group: Technology, Innovation and Society

## **A Strategic Niche Management Analysis: A Case Study of Electrifying Steam Crackers in the Netherlands**

Master Thesis, 45 ECTS

**C.R. Doherty, 1723146**

### **Supervisors**

Prof. Dr. H.C. de Coninck	TU Eindhoven, IEIS, Technology, Innovation and Society
Prof. Dr. Ir. A.J. Wiczorek	TU Eindhoven, IEIS, Technology, Innovation and Society
Dr. Ir. J.M.N. van Kasteren	TU Eindhoven, ME, Power & Flow
A.H.G. Oei	Accenture
G.M. Houben	Accenture

Eindhoven, 25 August 2023

This report was made in accordance with the TU/e Code of Scientific Conduct for the Master thesis.  
This master's thesis is public information

## Abstract

Steam cracking is a petrochemical process in which larger hydrocarbons are broken down into smaller hydrocarbons. It is a key process in the production of ethylene, propylene and other C4 olefins. These are used in manufactured goods like plastics, polymers, and solvents. Historically, the steam cracking process has relied on fossil fuel as a feedstock and energy source, but recent advances have led to an innovative hydrocarbon cracking method which uses electricity to drive the reactions, reducing carbon losses and emissions. The electrification of this process could avoid about 3 to 5 MT of annual CO<sub>2</sub>-eq emissions in the Netherlands alone. The aim of this report was to establish a base level understanding of the electric steam cracking niche and provide a protective space analysis of the socio-technical system by employing a strategic niche management (SNM) approach. Ten semi-structured interviews were held with actors in the niche and regime to describe how the three pillars of SNM - shielding, nurturing and empowering - have been implemented in the Netherlands. Key findings indicate that the niche emerged in the Netherlands due to the existing knowledge base, sufficient material infrastructure, and government support schemes to fund research. Although the niche has developed a broad and deep network, it suffers from a lack of shared learning due to competition between actors. The niche faces key challenges in ensuring that electricity generation and capacity is available, that site integration like alternatives for steam generation are provided, and most importantly, that the techno-economic performance of the innovation is improved. A lack of economic incentive to implement electric cracking within the Netherlands was found, and participants called for subsidies to shield early adopters from additional costs. The SNM framework had limitations because of the international nature and global niche effects on local dynamics within the Netherlands. Further research is suggested to focus on the international dynamics of the chemical industry's regime and how it affects decision making and development within the Netherlands and more generally, within the EU which will provide a larger context to this study.

## Executive Summary

Facilitating a sustainable transition of the chemical sector is essential to reaching 2050 net-zero climate goals. A key chemical process instrumental in providing the most produced chemical by volume, ethylene, is called steam cracking. Poor carbon efficiency and high heat requirements mean that large quantities of crude oil and gases are spent in a combustion chamber and worse, lost to the environment. An innovative solution to this is the electrification of the system of a steam cracker which means replacing the furnace with an electrically driven one and replacing other subsystems like drivers and pumps with electrically based ones.

Research into electrifying the cracking process has predominantly occurred in Europe and even more so, within the Netherlands, Germany, and Belgium. Though the technology has yet to reach demonstration scale, the research and development has had backing from incumbent actors and new actors and has seen growing interest over the course of a few years.

The aim of this research is to capture the foundation of the main actors within the network, identify and discuss the main strengths and weaknesses of the niche. This can serve to inform internal and external actors to help align expectations and learning for the niche. While the energy and material transition has begun and efforts are underway to reduce emissions, much remains unknown about future technologies and what the required enablers are for successful transformation of them into the wider socio-technical system.

*How has the electrified steam cracking niche developed within the Netherlands, and what are its strengths and weaknesses? And, how does using Strategic Niche Management to approach and analyze the electrified steam cracking niche diverge from or reinforce the credibility of the method?*

The main research question is provided above. Sub-questions were used to guide the research in answering the main research question and work to provide explanations on how the niche emerged, which actors and agents are prominent, and how they are shielded, nurtured, and empowered. The research design is based on qualitative data and literature reviews. There were 10 interviews conducted using a semi-structured format. The transcripts were coded according to the framework below in combination with codes representing emergent patterns.

The multi-level perspective theory segments society into three levels: landscape factors, pathway of regimes, and niche level. The pathway of regimes contains the systems that are the status-quo of how people interact and depend on institutional logic, technologies, governments and more. The landscape factors are exogenous events and trends that help to guide the regimes towards a new standard or reinforce what is currently done. On the niche level, radical innovation systems are developed with the hope of entering the regime. The specific study of the niche level management is called Strategic Niche Management

and involves considering three processes: shielding, when a space is protected providing experimentation to occur without selection pressures of the regime; nurturing, which considers the learning processes and access to resources both financial and network based; and lastly, empowerment, which is when a critical eye is taken to compare the niche to the regime.

The different technological approaches to electrification are explained. First, the conventional cracking approach burns naphtha, ethane, and other liquid petroleum gases in the furnace. The feedstocks are mixed with super-heated high-pressure steam and broken into smaller hydrocarbon chains like ethylene and propylene. There are different approaches to electrifying this process and they are championed by different actors. The most radical is a turbo machine which uses angled rotating fins to crack the hydrocarbons by creating shockwaves. Another option is using dielectric material to heat pipes providing the necessary heat duty to crack.

From the interviews, prominent actors were designated and through patent research and grey literature review, a diagram depicting the emergence of collaboration and advancement in technological readiness levels are shown. Developments progressed rapidly in the past four years with demonstration scale commitments arising in 2022 and 2023.

The Netherlands is suggested to have emerged as a protective space for the innovation system's development due to the pre-existing policy support like WBSO which is the Act for Research and Development Promotion. The WBSO provides tax credits for hours spent on R&D activities and stipulates other corporate tax rate reductions. Moreover, the geographic protection from already existing infrastructure and access to necessary resources allowed for research projects to be built in the Netherlands like at Chemelot.

Evidence of the niche's nurturing was found. Overall, expectations amongst participants were shared, but there was a large uncertainty in the policy landscape in the Netherlands and more broadly the EU. Expectations considering the readiness of chemical sites for integration of the technology was a concern for a majority of participants as well as the techno-economic performance. When integrating an electrically based steam cracker, the conventional method for steam generation is significantly reduced which means that replacing a cracker will have implications beyond just the olefin production stream itself. In addition to this effect, the electric crackers demand electricity on the scale of 500MW per site on average and in the range of GWs for the Netherlands in its entirety. Thus, if the goal is to reduce overall emissions, the grid ought to be equipped for firstly, generating enough renewable energy and secondly, managing transmission of it safely. This is a large challenge facing grid operators and chemical sites, especially when considering competition with other sectors for electricity supply. Lastly, the timeline of implementing the technology was not explicitly articulated by participants, though there was intention

expressed to install at least one electric cracker once the technology is proven at demonstration scale, and safety is assured; as previously explained, there are infrastructure and system side decisions that must be made in order to properly implement the electric crackers.

While the research focused on the local niches within the Netherlands, it became evident that participants had to make decisions considering the international dynamics of the chemical industry. Large multinational corporations (MNCs) drive the research around electric cracking and ultimately, decide where the new electric crackers are built. Participants indicated the difficulty of the Dutch business case citing expensive electricity and uncertain policy frameworks. Thus, since the business case for electric cracking is not feasible yet, participants suggested the need for additional subsidy to avoid the market penalty incurred by the early adopters of the new technology and incentive the investments within the Netherlands and within Europe.

Strategic Niche Management provided a framework to examine the internal dynamics of niches. Though there are multiple local niche developments in the Netherlands, the global niche and even global chemical regimes still likely had dominating effects on the dynamics within the Netherlands. This means the research would benefit from an expanded scope and further input from specifically globally focused actors. Moreover, using other innovation science analytical frameworks like the technological innovation system analysis instead of SNM could provide a more structured approach to understanding the market dynamics and entrepreneurial activities of the niche. Further research should be conducted with actors in the Netherlands, Germany, and Belgium to better describe their shared and unshared learning dynamics and globally to capture the international dynamics of decision making and learning processes. Similarly, conducting a multi-level perspective analysis is recommended to better understand and describe the relationship between landscape factors, regime characteristics, and the niche.

## Acknowledgements

*I would like to express my deepest appreciation to my academic supervisor, Prof. Dr. Heleen de Coninck, for her guidance and dedication throughout the research project. Without her expertise and patience, this project would not have been possible.*

*I would also like to thank Guido Houben and Alexander Oei for their unwavering support, dedication to the project, and mentorship throughout my internship at Accenture.*

*Also, I want to thank Dr. ir. Han van Kasteren and Prof. Dr. Ir. Anna Wiczorek for dedicating their time to reading the report and acting as assessors for the project.*

*Lastly, I want to thank all the participants of the study for providing their valuable time and insights.*

## List of Figures

<b>FIGURE 1: ETHANE TO ETHENE CONVERSION.</b> THIS ILLUSTRATION DEPICTS THE REACTION OF ETHANE, $C_2H_6$ , A SATURATED HYDROCARBONS IN A STEAM CRACKER BREAKING DOWN INTO ETHYLENE (ETHENE). THE RESULT IS THE CARBON-CARBON BONDS BREAKING, RELEASING THE HYDROGEN ATOMS AND THUS, BECOMING UNSATURATED (POSCH, 2011).....	2
<b>FIGURE 2: VISION OF CHEMICAL INDUSTRY.</b> THIS FIGURE SHOWS THE VISION OF A CHEMICAL INDUSTRY PRESENTED BY VOLTACHEM. THIS IS AN EXAMPLE OF HOW A DECARBONIZED CHEMICAL SITE COULD LOOK LIKE. (VAN DELFT & DE KLER, 2017).....	3
<b>FIGURE 3: MULTI-LEVEL PERSPECTIVE STRUCTURE.</b> THIS FIGURE IS A GRAPHICAL DESCRIPTION OF THE TRANSITION OF SOCIO-TECHNICAL SYSTEMS. THERE ARE THREE LEVELS: SOCIO-TECHNICAL LANDSCAPE, SOCIO-TECHNICAL REGIME, AND NICHE INNOVATIONS. THE LANDSCAPE PRESSURES EXERT PRESSURES TO SHIFT OR MAINTAIN THE REGIME WHILE NICHE-SPACES ALLOW FOR RADIAL INNOVATION DEVELOPMENT WHICH AIMS TO CHANGE THE COMPOSITION OF A REGIME. THE REGIME ITSELF HAS DIFFERENT FUNCTIONAL ASPECTS AS CAN BE SEEN, POLICY, TECHNOLOGY, ETC. (GEELS, 2011).....	9
<b>FIGURE 4: LOCAL NICHE EMERGING TO GLOBAL.</b> THIS FIGURE EXEMPLIFIES HOW SOCIO-COGNITIVE PROCESSES OCCUR INTERNALLY DURING NICHE FORMATION AND HOW IT EVENTUALLY GROWS INTO A REGIME. ADAPTED FROM (RAVEN & GEELS, 2010). .....	17
<b>FIGURE 5: DYNAMIC GLOBAL NICHE FORMATION.</b> A GRAPHIC DEPICTION OF HOW THE RELATION OF HOW A GLOBAL NICHE-LEVEL EMERGES FROM LOCAL EXPERIMENTATIONS. THIS IS A REMAKE OF THE ORIGINAL FIGURE FROM RAVEN AND GEELS (2010). .....	18
<b>FIGURE 6: ARRA REGION INDUSTRY MAP:</b> THIS MAP SHOWS WHERE ALL THE STEAM CRACKERS ARE IN THE ARRR REGION. (OLIVEIRA & VAN DRIL, 2021). .....	21
<b>FIGURE 7: WESTERN EUROPEAN PIPELINE NETWORK.</b> THIS MAP DISPLAYS PIPELINES LINKING DIFFERENT INDUSTRIAL CLUSTERS ACROSS THE ARR REGION (PORT OF ANTWERP, 2023). .....	27
<b>FIGURE 8: CHEMELOT SHARED STEAM.</b> THIS FIGURE SHOWS HOW A CHEMICAL SITE, HERE, CHEMELOT, INCREASES EFFICIENCY BY ACTING COLLECTIVELY, CONTRIBUTING TO AND USING A SHARED STEAM NETWORK (BRIGHTSITE, 2020). .....	27
<b>FIGURE 9: EU27 GLOBAL MARKET SHARE.</b> THIS FIGURE SHOWS GIVES AN OVERVIEW OF THE CHEMICAL SALES OVER THE PAST TWO DECADES IN PURE QUANTITY AND PERCENT OF MARKET SHARE. THE MARKET SHARE OF EUROPE HAS HALVED WHILE STILL GROWING OVERALL. (CEFIC, 2023). .....	28
<b>FIGURE 10: ETHYLENE COST BY REGION.</b> THIS FIGURE COMPARES THE REGIONAL COSTS OF OPERATING STEAM CRACKERS BETWEEN EUROPE, NORTH AMERICA AND THE MIDDLE EAST. EUROPE IS ALWAYS SIGNIFICANTLY MORE COSTLY. ADAPTED FROM (CEFIC, 2023). .....	29
<b>FIGURE 11: E-CRACKING PATENT RESULTS.</b> THIS FIGURE BY TIJANI ET AL. (2022) SHOWS A PATENT REVIEW ON CRACKING TECHNOLOGIES, NOT LIMITED TO ONLY STEAM CRACKING. ....	31
<b>FIGURE 12: STEAM CRACKING REACTIONS.</b> THIS FIGURE LISTS AND CHARACTERIZES THE REACTIONS WITHIN THE STEAM CRACKER'S REACTOR (LE VAN MAO, ET AL. 2013). THE MAIN PRODUCT $CH_2 = CH_2$ OCCURS IN THE PROPAGATION PHASE. IT IS IMPORTANT TO QUICKLY QUENCH THE HOT FEEDSTOCK MIXTURE TO AVOID UNWANTED OTHER PRODUCTS. ....	32
<b>FIGURE 13: CONVENTIONAL STEAM CRACKER DIAGRAM.</b> THIS FIGURE DEPICTS A SIDE VIEW OF A STEAM CRACKER. FROM IT, THE FLOW OF FUEL AND STEAM CAN BE SEEN AS WELL AS THE MAIN COMPONENTS OF THE REACTOR. SOURCE: ROSSI ET AL. (2019).....	33
<b>FIGURE 14: ETHYLENE PLANT.</b> THIS FIGURE CONTAINS A SCHEMATIC OF A TRADITIONAL ETHYLENE CRACKING SITE (VAN GOETHEM, 2010). THE FEEDSTOCK ENTERS ON THE LEFT ARE CRACKED AND CONTINUE ONWARDS FOR FURTHER PROCESSING. AFTER QUENCHING, THE PRIMARY FRACTIONATOR SEPARATES OUT CERTAIN PRODUCTS. THEN, THE PRODUCTS CONTINUE ONWARDS TO THE COLD SECTION TO BE COOLED AND SEPARATED INTO THE INDIVIDUAL PRODUCT STREAMS. ....	34
<b>FIGURE 15: SHOCKWAVE PYROLYSIS DIAGRAM.</b> THIS FIGURE IS A POSITION TIME GRAPH, REPRESENTING A SHOCK TUBE OR A REACTOR USING SHOCKWAVES. ON THE X-AXIS, THE LENGTH OF THE TEST REACTOR IS SHOWN, WHILE TIME IS PLOTTED ON	

THE Y-AXIS. A SHOCK WAVE TRAVELS ACROSS THE TEST SECTION, AS DOES A RAREFACTION WAVE. THESE SHOCK WAVES CAUSE A JUMP IN TEMPERATURE AND PRESSURE WITHIN THE REACTOR (BHASKARAN & ROTH, 2002). ..... 35

**FIGURE 16: SHOCKWAVE PYROLYSIS PATENT 1993:** THESE TWO PANELS DEPICT A PATENT FILING OF THE SHOCKWAVE PYROLYSIS (HERTZBERG ET. AL., 1993). ..... 36

**FIGURE 17: ROTO DYNAMIC REACTOR.** THE TOP FIGURE SHOWS THE ROTODYNAMIC REACTOR FROM COOLBROOK, FEATURING THE INNOVATIVE CURVED BLADES ALLOWING FOR HIGH LEVELS OF CONTROL (SEPPALA, J. ET AL., 2016) THE BOTTOM FIGURE SHOWS THE DIFFERENCE IN SIZE BETWEEN THE RDR AND A CONVENTIONAL FURNACE (RUBINI ET AL., 2022)..... 37

**FIGURE 18: SABIC ELECTRICALLY POWERED FURNACE.** THIS SHOWS THE DIAGRAM FOR AN ELECTRICALLY POWERED FURNACE. THE FEED COMES IN FROM THE LEFTHAND SIDE AND INTO THE TUBING. BOTH FIGURES COME FROM THE PATENT (CITE). THE SERIES OF TUBES HAVE AN ALTERNATING PATTERN OF TUBE BEING A HEATING ELEMENT (RE) AND THE TUBES FILLED WITH FEEDSTOCK (RT) (STEVENSON, S. ET AL., 2023). ..... 38

**FIGURE 19: INDUCTION HEATING PATENT.** THESE TWO PANELS DEPICT THE PATENT DIAGRAM FROM A PATENT (MORTENSEN ET AL., 2017). ..... 39

**FIGURE 20: ACTORS TIMELINE.** THIS FIGURE CONTAINS THE INFORMATION PUBLISHED BY COMPANIES AND RESEARCH ORGANIZATIONS ON JOINT VENTURES, AGREEMENTS, AND SOME PATENTS. THIS AIMS TO HELP CHARACTERIZE THE NETWORK TYPOLOGY CHRONOLOGICALLY IN THE ARRA REGION. .... 42



## List of Tables

<b>TABLE 1: THESIS REPORT OUTLINE.</b> THIS TABLE CONTAINS THE OUTLINE OF THE THESIS REPORT. ....	5
<b>TABLE 2: PRISONER’S DILEMMA MATRIX.</b> THIS TABLE COMES FROM THE (KUH, 2019). THE MATRIX ABOVE REPRESENTS THE PAYOFF OF TWO ACTORS CONSIDERING BOTH OF THEIR CHOICES. T>R>P>S IS THE PREFERENCE RANKING OF THE OUTCOMES.....	11
<b>TABLE 3: SNM ARTEFACTS OF 3 PILLARS.</b> THIS TABLE FROM VERHEES ET AL. (2013A) DETAILS THE THREE CATEGORIES OF STRATEGIC NICHE MANAGEMENT BY PROVIDING TYPES OF EVIDENCE THAT DEMONSTRATE THE DYNAMICS OF THE SYSTEM .....	13
<b>TABLE 4: SUB-QUESTION PER CHAPTER.</b> THIS TABLE CONTAINS HOW EACH SUB QUESTION WAS ADDRESSED, SHOWING THE METHOD OF DATA COLLECTION AND ANALYSIS. ....	22
<b>TABLE 5: PARTICIPANT INFORMATION.</b> THE TABLE PROVIDES INFORMATION ON THE PARTICIPANTS OF THE STUDY, LIKE THEIR EXPERIENCE AND HOW LONG THE INTERVIEW LASTED.....	23
<b>TABLE 6: LIST OF ACTORS.</b> THIS TABLE CONTAINS THE ACTORS MENTIONED IN INTERVIEWS ACCORDING TO THEIR CATEGORY AND ROLE IN THE SYSTEM.....	43
<b>TABLE 7: EMPOWERMENT STRATEGIES: RECOMMENDATIONS FOR ‘FIT AND CONFORM’ OR ‘STRETCH AND TRANSFORM’,</b> THE STRATEGIES COLUMN IS BASED ON RAVEN AND SMITH (2012) AND LEVIDOW ET AL. (2014) AS THE RECOMMENDATIONS INFORMED BY THE STUDIES. ....	58
<b>TABLE 8: CODEBOOK FOR DATA ANALYSIS.</b> THIS TABLE CONTAINS INFORMATION ON THE CODE USED TO ANALYZE THE COLLECTED DATA.....	81

## Contents

<b>Abstract.....</b>	<b><i>i</i></b>
<b>Executive Summary.....</b>	<b><i>ii</i></b>
<b>Acknowledgements.....</b>	<b><i>v</i></b>
<b>List of Figures.....</b>	<b><i>vi</i></b>
<b>List of Tables.....</b>	<b><i>viii</i></b>
<b>1. Chapter 1: Introduction .....</b>	<b><i>1</i></b>
<b>1.1 Background.....</b>	<b><i>1</i></b>
<b>1.2 Research Problem and Gap.....</b>	<b><i>4</i></b>
<b>1.3 Research Questions.....</b>	<b><i>5</i></b>
<b>1.4 Reading Guide.....</b>	<b><i>5</i></b>
<b>2 Chapter 2: Theoretical Framework.....</b>	<b><i>7</i></b>
<b>2.1 Multi-level Perspective.....</b>	<b><i>7</i></b>
<b>2.2 Strategic Niche Management.....</b>	<b><i>11</i></b>
<b>3 Chapter 3: Methodology .....</b>	<b><i>20</i></b>
<b>3.1 Case Description.....</b>	<b><i>20</i></b>
<b>3.2 Research approach.....</b>	<b><i>21</i></b>
<b>3.3 Overview of Methods Used .....</b>	<b><i>22</i></b>
3.3.1 Semi-structured interviews .....	<i>22</i>
3.3.2 Literature Review.....	<i>24</i>
3.3.3 Coding.....	<i>25</i>
<b>4 Chapter 4: Petrochemical Industry &amp; Steam Cracking Technologies.....</b>	<b><i>26</i></b>
<b>4.1 Industry Composition .....</b>	<b><i>26</i></b>
<b>4.2 Technologies Available .....</b>	<b><i>29</i></b>
4.2.1 Conventional technology.....	<i>31</i>
4.2.2 Shockwave .....	<i>35</i>
4.2.3 Direct & Indirect heating .....	<i>38</i>
4.2.4 Oxyfuel & Improved TLE / system improvements.....	<i>39</i>
<b>4.3 Policy.....</b>	<b><i>40</i></b>
<b>5 Chapter 5: Steam Cracking: Protective Space Analysis.....</b>	<b><i>42</i></b>

<b>5.1</b>	<b>Actors</b> .....	<b>42</b>
<b>5.2</b>	<b>Shielding</b> .....	<b>46</b>
<b>5.3</b>	<b>Nurturing</b> .....	<b>50</b>
5.3.1	Expectations.....	50
5.3.2	Actor Networks.....	54
<b>5.4</b>	<b>Empowerment</b> .....	<b>55</b>
5.4.1	Main Challenges.....	55
5.4.2	Fit and Conform.....	57
5.4.3	Stretch and Transform.....	59
<b>6</b>	<b>Chapter 6: Conclusion</b> .....	<b>60</b>
<b>6.1</b>	<b>Main findings</b> .....	<b>60</b>
<b>6.2</b>	<b>Recommendations</b> .....	<b>62</b>
6.2.1	Optimal Use of Thesis Results.....	62
6.2.2	Key Findings and Recommendations.....	63
<b>7</b>	<b>Chapter 7: Discussion</b> .....	<b>65</b>
<b>7.1</b>	<b>Practical Implications</b> .....	<b>65</b>
<b>7.2</b>	<b>Theoretical Implications</b> .....	<b>67</b>
<b>7.3</b>	<b>Limitations</b> .....	<b>69</b>
<b>7.4</b>	<b>Further research</b> .....	<b>69</b>
	<b>Bibliography</b> .....	<b>70</b>
	<b>Appendix</b> .....	<b>79</b>
	<b>A.1 Topic guide</b> .....	<b>79</b>
	<b>A.2 Codebook</b> .....	<b>81</b>

# 1. Chapter 1: Introduction

## 1.1 Background

As climate change puts increasing pressure on our ecosystems, global efforts to reach net zero emissions are underway. The landmark adoption of the 1992 United Nation Framework Convention on Climate Change (1992) represented a united front to limit greenhouse gas (GHG) emissions of industrialized nations. Since then, the Paris Agreement in 2015 was adopted and predicated on reports by the Intergovernmental Panel on Climate Change (IPCC). These reports underscore the importance of remaining below 1.5°C change in average temperature (Allen et al., 2018), and the Paris Agreement consisted of a binding agreement from nationally proposed plans by its participants, regarding climate policy. Most recently, the European Union's (EU) 'Fit for 55' implementation package lays the foundation for member states to envision a 55% reduction in emissions compared to 1990 levels. With this goal, combined with pre-existing mechanisms like carbon emission trading systems are presently being used to implement this transition. Industries like steel, cement, and chemicals face a long road to decarbonization. To comply with the EU targets, the chemical industry needs to decarbonize downstream processes by 2040.

The chemical industry is heavily reliant on fossil fuels across the value chain, from feedstocks to heat generation and to products themselves. While it supports 1.2 million workers directly and 3.6 million indirectly in Europe (Cefic, 2023), it faces fierce competition in the international market, where fluctuations in gas and electricity prices have large effects on the capacity factor of plants (Cefic, 2023). The chemical industry is globally responsible for an upwards of 1,257 MtCO<sub>2</sub>-eq/yr of scope 1 emissions in 2019, which balloons to 2,520 MtCO<sub>2</sub>-eq/yr considering scope 3 emissions (Teske et al., 2022). Ethylene is a driving force behind this number, having more than 205 million tonnes of annual production capacity in 2020 with an emission intensity of 1.44 kg CO<sub>2</sub>-eq per kg of ethylene (Statistica, 2022 and Negri & Lighthart, 2021). Ethylene is a bulk chemical and a base material for "polymers, synthetic fibers, rubber and plastic material" (Gholami et al., 2021). It is also used to synthesize polyethylene, ethylene oxide, ethylene glycol and ethanol; all of these account for 90% of production use (Rossetti et al., 2020). Moreover, various other light olefins are synthesized along with ethylene in its production, such as propylene. These chemicals are predominantly produced via a type of thermal pyrolysis, commonly referred to as steam cracking. Steam cracking is the process of heating longer hydrocarbons in the presents of hot steam to break the longer hydrocarbons into smaller products.

Steam Cracking is the process used to produce light olefins and has been around since the 1920s (Amghiziar et al., 2017). It's a highly endothermic reaction and thus, requires large amounts of heat to drive the reaction creating a large carbon footprint. While its exergetic efficiency is about 40%, the overall system efficiency ranges in the upwards of 90% range (Yuan et al., 2019). As such, the global emissions associated with steam cracking are large on the order of 366Mt CO<sub>2</sub>-eq/yr (Tijani et al., 2022), nearly a fourth of the chemical industries emissions.

Since the 2008 shale gas revolution in North America, steam cracking has undergone a feedstock transition, resulting in a more pronounced geographical dependence on operational choices. In the United States, lighter shale condensates, like ethane, are abundant and more readily substituted as a feedstock in steam cracking (Wu et al., 2021; and Amghizar et al., 2017). In contrast, Europe typically relies on naphtha which comes from the first distillation of crude oil. Moreover, depending on the feedstocks, certain products are favored. For example, with naphtha, a larger quantity of high value chemicals is synthesized than when a predominantly ethane feedstock used.

Figure 1 illustrates the targeted chemical reaction. The presence of the steam within the reactor decreases the partial pressure of the ethane, allowing for the synthesis of ethylene.

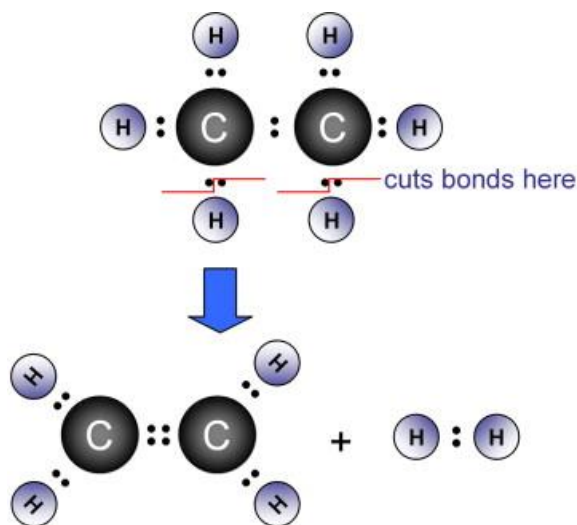
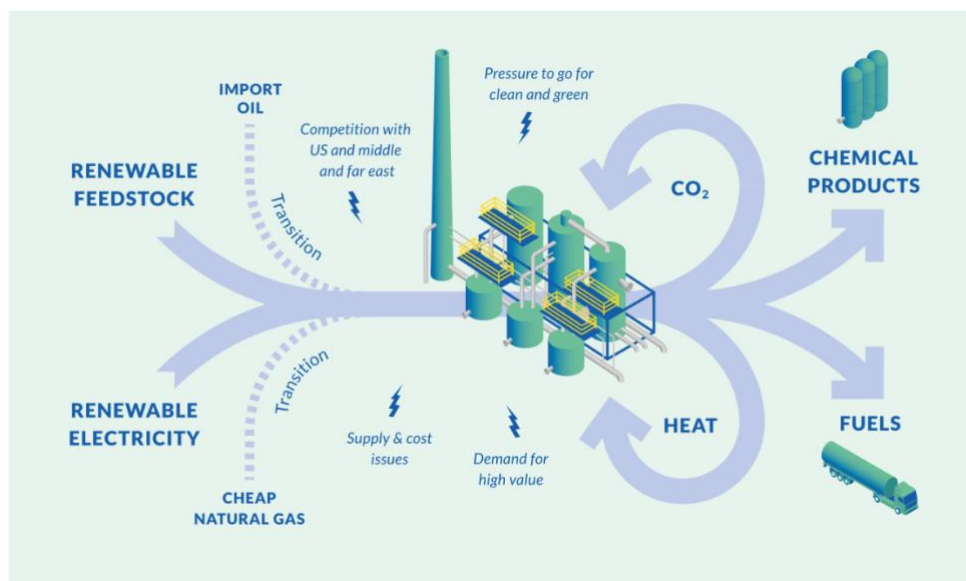

**Figure 1: Ethane to Ethene Conversion.** This illustration depicts the reaction of ethane, C<sub>2</sub>H<sub>6</sub>, a saturated hydrocarbons in a steam cracker breaking down into ethylene (ethene). The result is the

carbon-carbon bonds breaking, releasing the hydrogen atoms and thus, becoming unsaturated (Posch, 2011).

This cracking process is energy intensive: per kilogram of ethylene, 22.4MJ of primary energy is required (Negri & Ligthart, 2021). These emissions and energy requirements begin to grow quickly when considering the scale of production. Within the Benelux region, there is nearly 5MT/yr of ethylene capacity (Cefic, 2023). Moreover, a consequence of this heat demand highlights the importance and struggle of substituting fossil fuels for equally performing alternatives. Due to the liquid states and high energy densities, fossil fuels provide a stable and well-known route to create high temperature environments. Consequently, hydrocarbon cracking can be classified as a hard-to-abate industrial process, and the scientific community and industry alike are searching for ways to decrease emissions to achieve net zero emissions by 2050 while maintaining economic feasibility.

A key alternative to the fossil intense product route is the electrification of the cracking process. Electrification is aimed at replacing the feedstock used for heating purposes. And if the used electricity is generated through renewable sources, then it will reduce the GHG emissions. Figure 2 presents a vision of a decarbonized chemical plant. It shows how renewable feedstocks and renewable electricity are inputs replacing oil imports and natural gas. The by-products of CO<sub>2</sub> and heat can be reutilized while the value products, such as chemicals and fuels are passed along down the supply chain.



**Figure 2: Vision of Chemical Industry.** This figure shows the vision of a chemical industry presented by VoltaChem. This is an example of how a decarbonized chemical site could look like. (van Delft & de Kler, 2017).

Such a vision is an important learning tool in advancing a system transition, according to innovation studies. Forecasting is imagining what the future would look like given a transition which allows actors within a system to potentially share a more similar expectation for the future. An analytical framework called the Strategic Niche Management (SNM) describes criteria to assess a subsystem of actors working on a socio-technological system that is radically different from the current status quo. Additionally, in conducting an SNM study, the internal niche dynamics of actors are considered on three parameters: shielding, nurturing, and empowerment. An SNM study can be performed for ex-ante analysis or for advisor analysis which means looking at how a niche emerged (or failed to) and entered the regime or what actors could do to increase the uptake of the niche. This is explained in Chapter 2.

## 1.2 Research Problem and Gap

Steam cracking has been around since the 19<sup>th</sup> century. The underlying mechanics and requirements are well understood by the chemical industry and steam crackers are used globally every day. The advent of the decarbonization movement has made clear that the traditional approach to steam cracking is in stark contrast to societal and environmental demands. Yet, its alternatives are not well understood by the public and even actors within the field. Publicly accessible information on how the electrification of steam cracking is progressing is limited, and is understood even less, by both industrial actors and climate activists. An initial literature search with key words, “electrification of steam cracking” yields technical papers on kinetics modelling, two relevant review articles of the electrification of steam cracking, and one relevant industry conference paper, conducted in January 2023. One review article is by Tijani et al. (2022) and gives a comprehensive literature overview of different available technologies but fails to address a social component of the innovation, such as involved actors, shared expectations, and more.

According to the International Energy Agency (IEA, 2022), electrification of naphtha steam cracking is at a technological readiness of 3 which means the concepts need validation, and that solutions need to be prototyped and applied. Across Europe, there are consortia of researchers, companies, and universities coming together, patenting innovative technology and publishing press releases. In fact, there are few scientific articles addressing this (public) knowledge gap, yet the evidence of technological development indicates there is a need for more research, in order to close the empirical gap between private operations and public understandings.

Since steam cracking is heavily polluting and is a pillar of the chemical industry within the Netherlands, research on the niche allows for a deeper understanding of the challenge in

transitioning the chemical industry. Providing details on internal niche dynamics and description of actors could allow for better decision making in undertaking this transition. Likewise, the threat of climate change and economic challenges facing the chemical industry only underscores the importance of this more. Moreover, a secondary goal of the study is to reflect on the SNM framework itself and provide feedback into the research domain. Overall, this is an important step as it can serve as a historical timestamp of how a transition is occurring (or failed to), which could be used to inform future transitions and transition studies.

### 1.3 Research Questions

Given the challenges and lasting effects of industrial decarbonization, it is imperative that there are studies aimed at explaining the innerworkings of the chemical industry.

***How has the electrified steam cracking niche developed within the Netherlands, and what are its strengths and weaknesses? And how does using SNM to approach and analyze the electrified steam cracking niche diverge from or reinforce the credibility of the method?***

1. How has the electrified cracking niche emerged and evolved over time?
2. What actors are prominent within the socio-technical innovation system?
3. What patterns (or strategies) exhibited by the actors can be identified in terms of shielding, nurturing, and empowerment?
4. Considering Strategic Niche Management, what strategies could be recommended to actors and why?
5. *Does the Strategic Niche Management framework effectively address the electrified steam cracking niche?*

By answering the questions and sub-questions above, this research addresses the problems of the limited socio-technical studies on the petrochemical industry, specifically on the high heat requirement concerns. Secondly, it focuses on an alternative socio-technical pathway in a heavily polluting industry which could contribute to further studies and solutions to mitigate emissions.

### 1.4 Reading Guide

**Table 1: Thesis Report Outline.** This table contains the outline of the thesis report.

SQ	Outline
-	Chapter 1: Introduction
-	Chapter 2: Theoretical framework



-	Chapter 3: Methodology
1,2,3	Chapter 4: Steam Cracking Technologies & Industry
1,2,3,4	Chapter 5: Steam Cracking Niche: Protective space analysis
4,5	Chapter 6: Conclusion
-	Chapter 7: Discussion

## 2 Chapter 2: Theoretical Framework

This chapter explains the theoretical framework which is taken as a starting point for the analysis, and which informs the methods by means of the interview guide found in the Appendix and elaborated on in Chapter 3. The aim of this chapter is to explain the Multi-level perspective analysis and Strategic Niche Management.

### 2.1 Multi-level Perspective

The Multi-level perspective (MLP) is a theory which is accompanied by a standardized analytical framework where socio-technical systems are studied to identify and understand patterns exhibited in system transitions. Geels (2002) explains that MLP is not an “ontological description of reality but an analytical and heuristic framework to understand [it].” The focus of study in this framework is the socio-technical system and is referred to as such because it considers the use of a technology, the actors, governance, and laws embedded in the system; hence, “socio-technical” aptly refers to all of these. A transition requires disruption and substitution of technologies, and often affects how users interact with such a technology.

The theory of MLP comes from a combination of “evolutionary economics” (trajectories, regimes, niches, speciation, path dependence, routines); science and technology studies (sense making, social networks, innovation as a social process shaped by broader societal contexts); structuration theory, and neo-institutional theory (rules and institutions as ‘deep structures’ from which knowledgeable actors base their actions; duality of structure, i.e. structures are both context and outcome of actions; and ‘rules of the game’ (that structure actions)” (Geels 2011). Therefore, by its nature, MLP can address multiple actors’ perspectives in terms of “technology, policy/power/politics, economics/business/ markets, and culture/discourse/public opinion” (Geels, 2011).

This means that the underlying system dynamics can be demarcated, thus allowing societal transitions between socio-technical systems to be studied. A few examples of the transitions are transformation, reconfiguration, technological substitution, de-alignment, and re-alignment (Geels, 2011). There are a number of MLP studies (Verbong & Geels, 2010; Elzen et al., 2011; Walrave et al., 2018). All of the many iterations of MLP theory are subject to a common criticism due to its very nature: since it is a middle-range process theory, MLP focuses on inherently complex subjects. For this reason, its methodology is less-straight forward and therefore, less reproducible compared to non-empirical studies. Geels (2011) counters this by arguing that an intricate system cannot be studied in the same manner as a variance theory, since by doing so, the study itself constrains the complex subject and risks losing information.

In short, the multi-level perspective identifies three levels at which seemingly independent socio-technical systems can be pierced and impact one another. Beginning with the central layer, known as the “pathways of regimes,” socio-technical systems contain the norms of technology, policy, industry, science, and market preferences. These regimes have incumbent actors and standards for how they conduct business. An example of a socio-technical system is the energy system within the Netherlands. In this socio-technical system, rules and logic guide the actions of actors within the regime. The traditional fuel source in the Netherlands’ energy system is natural gas. However, the Dutch energy system is in the process of transitioning to sustainable energy technologies, such as wind (Verhees et al., 2013).

Above the central layer is the socio-technical landscape. This is where larger, overarching pressures are found, which pressures can function as actors of change, providing either stability to a regime or destabilizing it. Interestingly, these pressures are often beyond the control of those operating the regime. This phenomenon is referred to as “developments in the exogenous environment” (Raven, 2007). The current climate crisis is an example of a “development in the exogenous environment,” in that the climate crisis itself is exerting pressure on the pathway of regimes, externally forcing it to become cleaner, reducing its greenhouse emissions. This interaction between landscape pressures and regimes can be further studied with a multi-level perspective analysis. The lowest level is where niche innovations live and develop. Here, new innovations are given space to begin developing their social network around an innovation while improving the actual technology. This tiered system is illustrated in Figure 3.

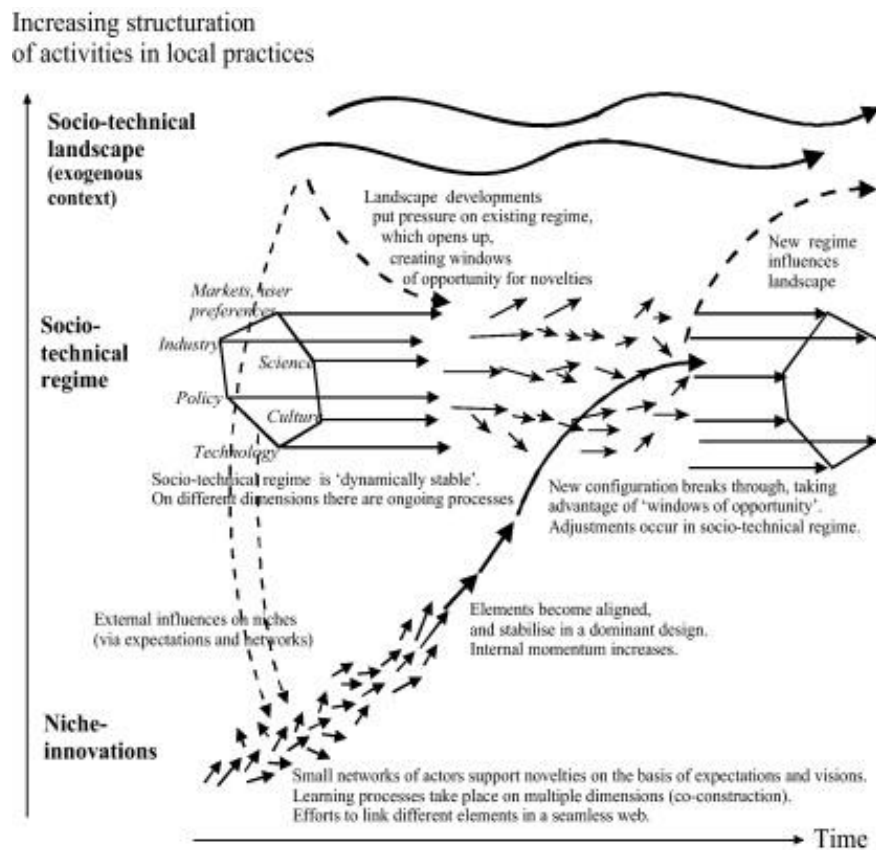

**Figure 3: Multi-level Perspective Structure.** This figure is a graphical description of the transition of socio-technical systems. There are three levels: socio-technical landscape, socio-technical regime, and niche innovations. The landscape pressures exert pressures to shift or maintain the regime while Niche-spaces allow for radial innovation development which aims to change the composition of a regime. The regime itself has different functional aspects as can be seen, policy, technology, etc. (Geels, 2011).

Multilevel perspective analysis aims to understand socio-technical transitions, and this field of research is a mix between complex systems and transition management. Complex systems (CS) have vocabulary to describe the system itself which includes nonlinear interactions, feedback loops, co-evolution, self-organization. This kind of behavior leads to emergent properties and patterns which create a path dependency in the systems transitions. Rotmans and Loorbach (2009) explain how transition arenas should have reflexive learning, having made their point by contrasting CS to industrial ecology in which the focus is on optimizing material flows, rather than questioning if flows should be optimized or even whether they exist in the first place. This reflection gains more value, especially when considering niches in the chemical industry, which can have profound societal impacts and exhibit high levels of lock-in due to the large investments and polluting nature of chemical sites themselves. The overarching landscape pressures weigh heavily

towards a sustainable future from a societal perspective, while at the same time being at odds with current business models.

Another prominent analytical framework within transition literature is the technological innovation system (TIS) analysis. A TIS analysis examines the structural and systemic functional units of an innovation system separated into seven categories. The seven categories are entrepreneurial activities, knowledge development, knowledge diffusion, guidance of the search, market formation, resource mobilization, and advocacy coalition (Kao et al., 2019). Like MLP, it has regimes, a corollary pathway of regimes which compete, and a level for landscapes (Markard, J., & Truffer, B. (2008). However, a TIS is more comprehensive approach than MLP and SNM alone. SNM focuses on radical innovation which is why it is chosen as implementing electric steam cracking requires permanent system alteration.

The MLP theory is often applied to sustainable transitions. Geels (2011) addresses common criticisms of MLP. In doing so, he singles out the difficulty faced in a sustainable transition. An actor within the socio-technical system has conflicting motives as sustainable choices often have less economic incentives. This issue has been addressed by many academic researchers and falls into two prototypical dilemmas: “Tragedy of the Commons” and the “Prisoner’s dilemma.” The former is the situation in which a common good is used with non-excludability and competition, and the logic that flows from this is that actors will benefit themselves to the detriment of the others, since they do not feel the full effect of the repercussions of their actions.

For example, farmers feeding their own cattle from a public trough (more so than they would if it were their own since they have free access to it). Such an act ultimately reduces the total amount of grain available for the public to consume but benefits the farmers since they solely receive the benefit of the additional cattle (Lloyd, 1980). This demonstrates a feature of unfettered capitalism wherein there is no effective mechanism to represent the common good (Brook, 2001). Moreover, another complication in the decision making of an actor in a sustainable transition, can be seen in The Prisoner’s Dilemma (see table 2). Here, two parties have an option whereby cooperation benefits them both, while without cooperation, both are worse off. Paradoxically, however, a complication in this situation is that one party is better off if the other acts as if they were cooperating (Kuhn, 2019). This decision matrix can be seen in Table 2.

**Table 2: Prisoner’s Dilemma Matrix.** This table comes from the (Kuhn, 2019). The matrix above represents the payoff of two actors considering both of their choices. T>R>P>S is the preference ranking of the outcomes.

	<i>C</i>	<i>D</i>
<i>C</i>	R,R	S,T
<i>D</i>	T,S	P,P

This is a simplistic model illustrating that cooperation could benefit a system while also showing that a party acting in their own interest can result in an overall worse situation for everyone. While a recent study argues that the Tragedy of the Commons dilemma can be considered as an extended case of the Prisoner’s dilemma with finitely large parties (Carrozzo Magli et al., 2021), it is still applicable here. Furthermore, they argue that with more players, each actor’s share of culpability felt diminished. This correlates to a central problem in sustainability - that each person is contributing to climate destruction, for example, by emitting greenhouse gases into a collective atmosphere. This issue of increasing actors gains special importance in climate transitions because nearly the entire system must undergo radical changes. With so many actors and agents, the inherent asymmetry in knowledge and information available, and communication difficulties within socio-technical systems are persistent. Meaning, that if a sustainable transition necessitates that actors must work in collaboration, then coming to agreements on the proper steps to mitigate climate change is a long and complicated process.

The action by governments like the European Union to enact caps on carbon emissions mitigates these previously mentioned dilemmas by providing accountability and penalties for polluting public goods, in this case, the atmosphere. Moreover, from an MLP perspective, such regulation provides landscape pressures onto regimes to change their traditional modus operandi. Likewise, policies like ‘Fit for 55’ and ‘REPowerEU’ strongly raise these pressures since in many cases, compliance is required from industries if they wish to remain part of the socio-technical regime. A strength of these policies is that they earmark large amounts of funds to continue the development of innovative technologies. This means the policy is working at multiple levels in the eyes of MLP. By recognizing the importance of funding and setting hard goals for regimes, niches are given priority to help steer the pathway of regimes towards a more sustainable future. The study of this interaction from a niche perspective is called Strategic Niche Management (SNM).

## 2.2 Strategic Niche Management

Strategic Niche Management (SNM) focuses on the internal process of niche formation and how a niche is influenced by the regime, relying on the theoretical and analytical structures laid out in MLP. The definition of a niche is significant to the focus of this research. A niche

is a protected space where an innovation is shielded from the selection pressures of the regime. Hence, SNM allows for researchers and advisors to examine how innovations can challenge existing systems and most importantly, and to determine if it is possible to implement a particular innovation, and if so, how to implement and upscale it (Bruno, 2022). The SNM analytical framework provides three processes which all niches must undergo.

The first is shielding. Shielding is the process a niche undergoes where it receives either active or passive protection from the selection environments of the regime (Smith & Raven, 2012). Shielding can be geographical, for example, the niche may be granted an exemption from a specific law or laws or is provided subsidies by the regime or government of the jurisdiction. This relief from the regime's selection gives it space to continue to be fostered. Another process that may help the niche innovation takes the form of various kinds of nurturing. Nurturing is where the niche can build and strengthen its network, learning processes, and shared expectations (Schot & Geels, 2008; Smith & Raven, 2012). Lastly, a niche management calls for empowerment. Empowerment is where a niche advisor looks critically at the regime and itself, and then determines how the niche should act: should it try to stretch and transform the regime, or should it fit and thus conform to it? (Vergees et al., 2013).

Niches do not proceed consecutively through these three processes, but rather can experience varying degrees of all three processes simultaneously. Hence, understanding the processes a niche is undergoing provides valuable insight into developing the technology and increasing the odds of proliferation into the regime. This is the key to the success or failure of SNM regarding any given innovation: niche management is the central tenant of SNM. Barriers of a niche are assessed and considered in unison and a successful SNM would indicate a solution to such barriers which can be used to inform policy makers, industry actors, and other agents (Kemp et al., 1998). There is a large degree of complexity and variety in performing an SNM analysis, but what continues to drive its practice is that furthering innovations are essential in progressing our collective pathway of socio-technical regimes.

In the early works on SNM, the core question was “how does one create technological niches and manage them?” (Kemp et al., 1998). This idea has been examined by much research over the past three decades, and now SNM asks more than just “how,” but also “why does one succeed and why does one fail”? The goal is to truly understand the internal dynamics of success through SNM analysis. It has grown beyond what is laid out in the early works and now describes ways to assess a niche in terms of its shielding, nurturing, and empowerment, with Smith and Raven (2012) coining the term ‘empowerment’.

Smith and Raven (2012) outline the need for protective spaces and argue that the different logics of regimes exert (or create) different selection pressures. Each different regime dimension-logic contributes to the need for protective spaces in its own right. For example, the selection pressure of a regime’s industry dimension is described as “organizational networks, industry platforms, user-producer networks, shared industry routines, labor force, capabilities, etc.” — all of which are built on the logic of industrial protection. The need for protective space, in terms of a regime’s industry, is because path-breaking innovations often cannot directly integrate into the regime as the inherent path-dependency prohibits the innovation’s uptake (Smith & Raven, 2012). This highlights the importance of the mutual understanding, as well as the dynamic relationship between the regime and the developing innovation system.

**Table 3: SNM Artefacts of 3 Pillars.** This table from Verhees et al. (2013a) details the three categories of Strategic Niche Management by providing types of evidence that demonstrate the dynamics of the system

<b>Theoretical category</b>	<b>Evidence</b>
Shielding	Suitable geographic location
	Financial support
	Temporary rule exemptions for innovation
	Tolerating ‘poor’ economic/technological performance
Nurturing	Broad and reflexive learning
	Articulating specific and shared expectations
	Building broad and deep networks
Empowering	Arguing and promoting that innovation will be competitive under conventional criteria
	Arguing that no radical changes are required
	Framing shielding as temporary
	Framing nurturing as targeting performance improvement
	Arguing for and achieving institutional reforms
	Framing shielding as manifestation of sustainable values
	Framing nurturing as learning process towards sustainability

Shielding is one of the three pillars in SNM. Within literature, shielding has been identified in various ways. In an early paper on SNM, Kemp et al., (1998) do not explicitly refer to shielding, but do indeed discuss the concepts which are now referred to as shielding and the effect it can have on a niche. Moreover, at first, Kemp et al. (1998) touched on the importance of finding an appropriate location for a niche experiment, providing an example of electric vehicles used in a city as people benefit directly from its decreased emissions.



This experiment's location would be an example of passive shielding which Smith and Raven (2012) define as "generic spaces that pre-exist deliberate mobilization by advocates of specific innovations, but who exploit the shielding opportunities they provide." The influences of geographical proximities in niche experimentations have been discussed in literature and is considered later in the chapter.

On the other hand, active shielding requires intentional effort by actors and agents. These can be financial or social, such as funding R&D, lobbying, or NGO activism. The effect of different types of shielding and the amount or intensity of it, can be drastic. If there is too much shielding, too many resources can be attributed to an innovation which is a poor fit for a specific socio-technical system, resulting in a loss. Meanwhile, if there is too little shielding, a niche may be susceptible to the selection environment pressures of the regime and thus be prevented from fully developing. An example would be increasing the technological readiness or creating the proper networks to facilitate learning. For more details on the seven functions of a regime, see Smith and Raven (2012).

The second key attribute of SNM and MLP is to focus on the technology's network, the shared expectations, visions for the future, and learning feedback mechanisms. These are all encompassed in the nurturing process. Evidence of nurturing can be academic and industry networks forming, increased research output on improving efficiencies, or reducing cost (Verhees et al., 2013). Furthermore, trade organizations acting as liaisons between industry and research, or consortiums sponsoring experimentation, are examples of network development, that serve to both broaden and deepen the network.

Additionally, projects that focus on collaboration can help facilitate the learning processes, thereby nurturing the niche. It has also been argued that broad networks increase the second-order learning, if outsiders are included (Schot & Geels, 2008). The niche is considered deep if the actors and agents in the network have access to substantial resources (Smith & Raven, 2012). Shared expectations are an influential metric but can prove to be elusive and difficult to document when subjected to SNM analysis. A basic or dominant design for a technology can serve to guide a niche by providing a frame of reference for actors and agents (Kemp et al., 1998). From the beginning of SNM, the importance of developing a network and articulating shared expectations has been understood, and in tandem with the development of the theory itself, further examples of nurturing have been identified and illustrated.

The final process of SNM is empowerment. This process has been elaborated on and debated in recent publications (Hoogma et al., 2002; Smith & Raven, 2012; van Summeren et al., 2022). If the niche is slated to enter the regime, it is bound to either fit & conform or

stretch & transform the regime. Yet, the underlying methodology here is being re-evaluated in current literature because niche dynamics are complicated and sometimes operate in multiple dimensions (van Summeren et al., 2022). Niche hybridization is very similar to the strategy of “fit & conform” where a niche is already very well aligned with the regime in many ways, such as market or infrastructure (Raven, 2007). Whereas, for niche accumulation, niche hybridization is defined as the practice of applying a technology into different market niches (Raven, 2007). This allows the innovation to be replicated across different applications and can provide additional learning opportunities for the actors and agents. However, this aspect causes the niche to “stray” from the regime’s control. The notion of fit & conform can occur within a niche at different functional levels of the niche, e.g., in terms of actors and agents or technology. Questions needed to assess a regime’s attributes are given in the table below (van Summeren et al., 2022).

**Table 1:** This table is a proposed question list to analyze the niche hybridization strategies of a niche (van Summeren et al., 2022).

	<i>Elements</i>	<i>Description</i>
<i>Institutional logic</i>	Institutional orders	family, community, religion, market, state, profession, and corporation
	Goals	High-order goals of the field (embedded in institutional order(s))
	Means	What is the appropriate goal for an organization?
	Mission	Is the organization aiming to create economic, social, and/or environmental value for customers, shareholders, specific groups, and/or society as a whole?
<i>Organizations</i>	Organizational form	What is the appropriate organizational form to achieve that goal?  Examples of legal forms of organizations include corporations, organizations, cooperation, and non-governmental organization?
	Governance and ownership	How is control legitimately exerted in an organization? Who owns the organization?

<i>Technology</i>	Source of legitimacy	What are the sources of professional legitimacy in an organization (e.g. expertise, contribution to mission)?
	Favored technology	What technologies are favored by or constructed in line with different institutional logics? How are technologies (favored by different institutional logics) combined into new socio-technical configurations?
	infrastructure	Do socio-technical configurations rely on existing infrastructures for their functioning?

The point of the above table is to be able to assess the logics of an actor within the socio-technical regime or niche, thus, understanding the expectations and alignment of the actors. Moreover, it gives insights into the use and performance of the technology itself, in comparison to the regime. By further understanding the direction and logic of the regime, advisors to the niche are able to create a more informed strategy. The significance of this is that this analysis is the essence of empowerment as it enters regime and niche begin to merge.

### **Local & Global Niches**

The distinction between global and local niche does not follow logically from the geographical definition of the word global. The term global refers to a socio-cognitive set of rules and knowledge stored within the actors and agents of the individual local niches. A study by Raven and Geels (2010) discusses how the aggregation of local experiments evolves into a global socio-technical regime. In this article, they introduce “socio-cognitive additions” to SNM, arguing that socio-cognitive evolution occurs and is rooted in a recursive learning process. In figure 4, the structure of the local level to regime level, is laid out, while the arrows indicate the mutual influence that levels have on each other. The core of this argument is the interaction between local actors and the formation of global cognitive rules.

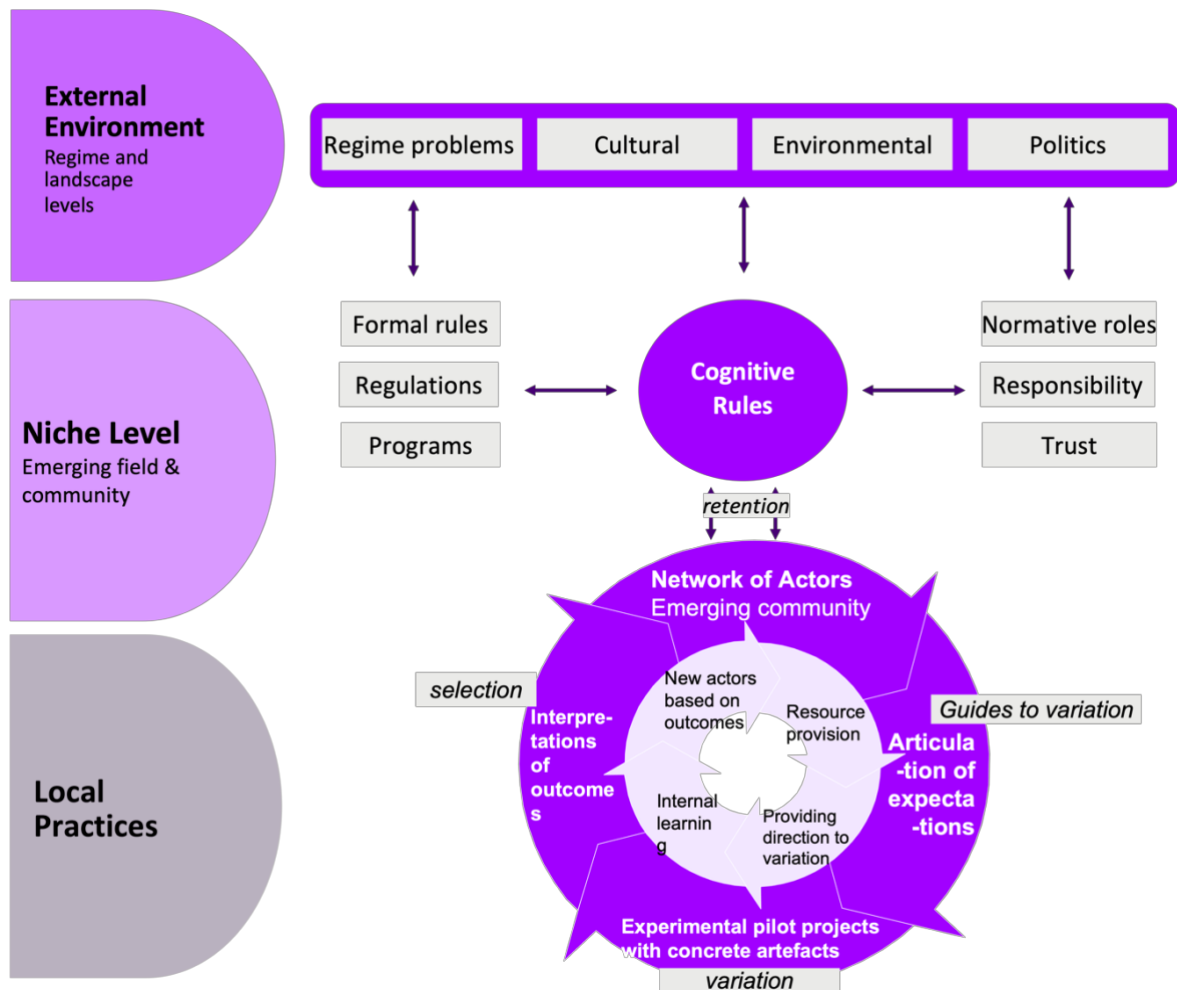

**Figure 4: Local Niche Emerging to Global.** This figure exemplifies how socio-cognitive processes occur internally during niche formation and how it eventually grows into a regime. Adapted from (Raven & Geels, 2010).

The concept that with experimental pilot projects, concrete artefacts are created and can be subsequently interpreted, is referred to as “*selection*.” Selection forms the basis of development for an emerging field. During selection, local actors have the chance to “make sense of experiences [or make a] construction of interpretations” (Raven & Geels, 2010). The chief objective of selection is to provide information back to the local experiment itself but also to provide general lessons at the niche level, through collective learning. Collective learning is where knowledge is exchanged at a level greater than the local experimentation. Examples where this occurs are “workshops, conferences, journals, and research grants” (2010). Collective learning helps shape the regime logic and expectations among actors — both within and outside a local experiment.

Another tenet of the socio-cognitive evolution is retention of knowledge at the global level. This requires actors and change agents to focus on how this information is stored within both local and global networks of actors. Retention at a global level emerges from the shared local interpretations. Moreover, the knowledge at the global level is argued to be more abstract than at the local level with cognitive rule formation prevailing. This can be seen in Figure 4 with how cognitive rules interact with the left and right boxes containing specific examples of what knowledge is retained. This pathway can be seen in Figure 5: Dynamic Global Niche Formation, wherein a global niche begins to form once the local niche experimentation undergoes this cyclical knowledge development and exchange.

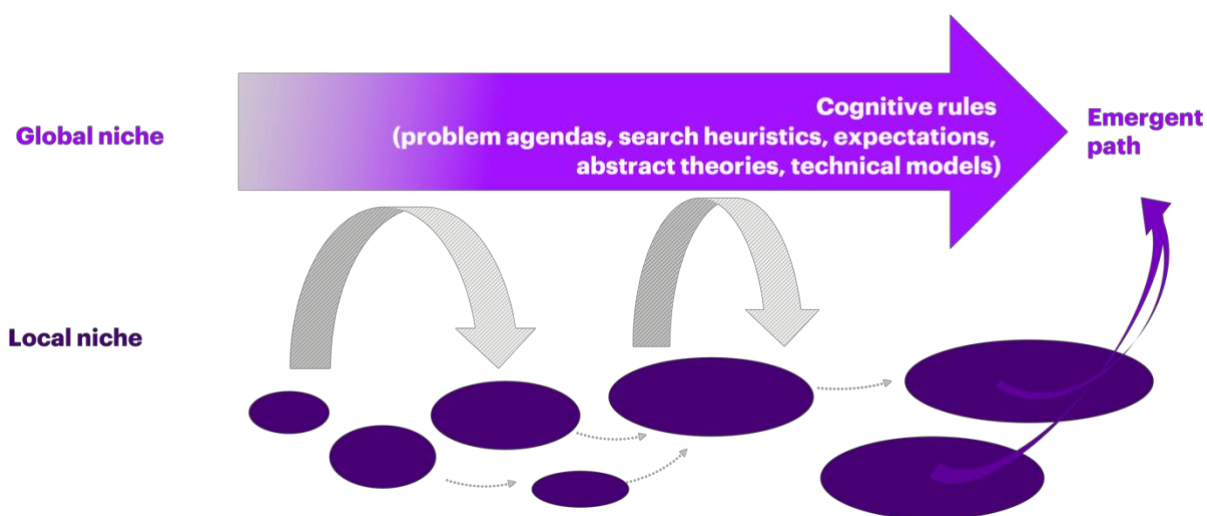

**Figure 5: Dynamic Global Niche Formation.** A graphic depiction of how the relation of how a global niche-level emerges from local experimentations. This is a remake of the original figure from Raven and Geels (2010).

Following the cycle in Figure 5, the “articulation of expectations” step allows the local experiments some space as they consider newly formed cognitive rules, assess the influence of new actors, and examine potential influences of the regime and landscape factors, all of which provides a direction for them to go in the next steps. Such an action creates a guide or indicates general direction on how to conduct the following pilot projects. This leads to variation within the subsequent pilot projects, which in itself, then closes the cycle, paving the way for further evolution and niche development.

Furthermore, the development of local experimentations and global niches has unique spatial qualities and dependencies, that affect its internal processes. As noted above, the geographical sense which the words “global” and “local” connote in everyday use, does not always hold true in the SNM context (Coenen et al., 2010). Here it is important to look at

the five functions of proximity laid out by Boschma, R. (2005) from a Strategic Niche management perspective. In their article, Coenen et al. (2010) argue for different combinations of proximities that benefit niches; however, the reasoning behind that is not empirical.

Wieczorek et al. (2015) investigated 65 sustainable experiments of PV systems in India to test their transnational links. They created a framework of five functional categories: Actors, Knowledge, Capital, Institutions, and Technology. Within each category, evidence of international linkages was tallied in order to characterize the degree of transnationalism. The results suggest a strong level of transnational presence within the sustainable experiments. Foreign investors, international research, international norms and regulations, foreign parts or technologies, are all indications of transnationalism.

### 3 Chapter 3: Methodology

In this chapter, first, the case description of electric steam cracking is given. This is followed by a statement of the research approach and explains how the answer to each sub-question was reached. Lastly, a detailed explanation of the employed methods is presented.

#### 3.1 Case Description

The case of electrification of the steam cracking niche within the Netherlands is examined in this study. This is a global niche analysis localized to the Netherlands, probing the individual local experiment actors. The technology of electrified steam cracking (referred to as e-cracking for short) does not have a set design, as described in Chapter 4. Since there are different electrification routes possible, there is more than one correct way as to how to implement the technology. Regardless, the use of innovative technologies demands feedstocks naphtha, ethane, and LPG to produce products and heat. It has a large radiant duty which is conventionally met with fuel gas and high-pressure steam. See Chapter 4.2. This creates a dependence of the socio-technical niche on market conditions of electricity and fuel prices, as well as exposing it to emission legislation caps. By implementing e-cracking, scope 1 emissions of cracking sites would drop sharply, and depending on the emission factor of the nation's grid, scope 2 and 3 emissions also decline.

As these cracking sites are large and produce a continuous flow of products, they are closely linked with other industries. Often both feedstocks and products are piped directly to surrounding industry, as in Chemelot, for example. These ties mean that any change to operations could create a ripple effect across the value chain, thereby putting revenues at risk. There are examples of experimentations by companies, such as DOW, Shell, Sabic, BASF, Linde, and Coolbrook in Germany, Belgium, and the Netherlands. Furthermore, e-cracking's high energy demand necessitates close operation with the TSO to ensure generation and transmission of electricity. In terms of university-industry partnerships, the aforementioned companies have close ties to the following universities: TU Delft, University of Ghent, and University of Oxford and more as described in Chapter 5.1.

The scope of this research is limited to the socio-technical system of electric steam cracking within the Netherlands. Though the chemical industry is inherently global, its presence and significance within the Netherlands is made abundantly apparent by the importance of sites like Chemelot, Moerdijk and others, especially, as these sites dominate the local industry. The tristate area of the Netherlands, Germany, and Belgium constitute the ARRA region, more specifically, Antwerp-Rotterdam-Rhein-Ruhr-Area, and contributes to 40% of EU petrochemical production (Cefic, 2023). It has strong ties to universities, governments, and institution going back decades.

The niche operates within a large regime of the chemical industry, specifically the regime which produces, distributes, and consumes ethylene and similar products to refineries and manufactures downstream. The regime is composed of large multinational companies that “operate under a highly stable, global, and rather unsustainable socio-technical regime”(Bauer & Fuenfschilling, 2019).

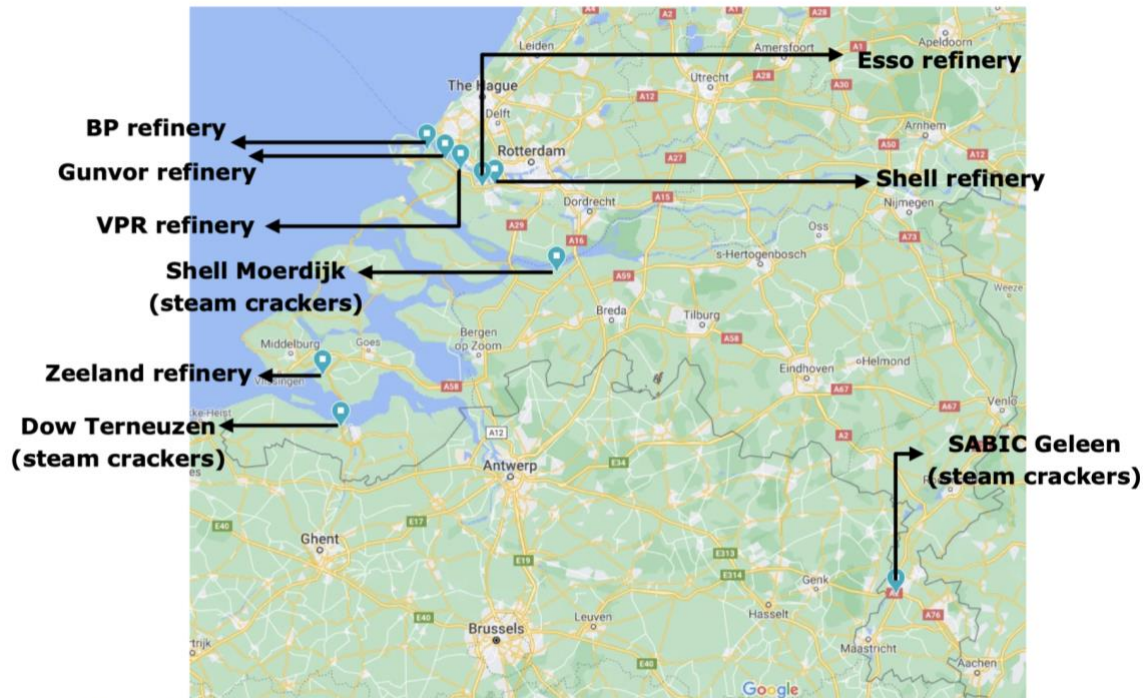

**Figure 1 - Locations of refineries and steam crackers in The Netherlands**

**Figure 6: ARRA Region Industry Map:** This map shows where all the steam crackers are in the ARRR region. (Oliveira & van Dril, 2021).

In Figure 6, the Dutch refineries and steam crackers are shown. There are three sites where the units are situated: Terneuzen with DOW, Geleen with SABIC, and Moerdijk with Shell. Further description of the Dutch system is given in Section 4.1.

### 3.2 Research approach

The first sub-question was addressed by an historical analysis of events in society, specifically with policy and economic reasoning. This was done based on a literature review and responses of interviewees. Similar to sub-question 1, sub-question 2 relies on existing literature and on the results of interviewees. Sub-question 3 relies heavily on the Strategic Niche Management framework described in Chapter 3. The semi-structured interview format allowed participants to expound upon their view of how to operate within the socio-technological system and describe what they saw occurring within the socio-technical



system from their perspective. Sub-question 4 requires a perspective change from an historical employment of SNM to an ex-ante analysis. This was based on the semi-structure interview code and motivated by scientific literature. Sub-question 5 was addressed based on an analysis of how well equipped the methodological framework was in characterizing the actions of the socio-technical system.

**Table 4: Sub-question per Chapter.** This table contains how each sub question was addressed, showing the method of data collection and analysis.

	<i>Research Question</i>	<i>Method and data Collection</i>	<i>Data Analysis</i>
<i>SQ1</i>	How have the electrified cracking niches emerged evolved over time?	Literature study (scientific + nonscientific literature) & Semi-structured qualitative interviews	Primary and Secondary data analysis + codification in NVivo
<i>SQ2</i>	What actors are prominent within the socio-technical innovation system?	Literature study (scientific + nonscientific literature) & Semi-structured qualitative interviews	Primary and Secondary data analysis + codification in NVivo
<i>SQ3</i>	What patterns (or strategies) exhibited by the actors can be identified in terms of shielding, nurturing, and empowerment?	Literature study (scientific + nonscientific literature) & Semi-structured qualitative interviews	Primary and Secondary analysis + codification in NVivo
<i>SQ4</i>	Considering Strategic Niche Management, what strategies could be recommended to actors and why?	Literature study (scientific + nonscientific literature) & Semi-structured qualitative interviews	Primary and Secondary analysis + codification in NVivo
<i>SQ5</i>	Does the Strategic Niche Management framework effectively address the electrified steam cracking niche?	Literature study (scientific + nonscientific literature)	Secondary analysis

### 3.3 Overview of Methods Used

Data collection in this study was done via two routes: semi-structured interviews and literature reviews.

#### 3.3.1 Semi-structured interviews

The main form of data collection was through semi-structured interviews. The participants were either found through the network of the supervisor or researcher, from a seminar on

electric cracking by SPIN-NL, and by snowballing. The participants were invited because they were actively involved in the technological development and/or system integration of electric cracking. Likewise, they held knowledge on the use of electric cracking, were in positions of responsibility for its implementation or were knowledge about the system needed for implementing the technology.

In total, ten interviews were held with eleven participants. The interviews lasted on average 60 minutes with 10-15 minutes going towards reviewing the consent form and conducting introductions. After the interview, a transcript was produced, pseudonymized, and then confirmed by the participant. This allowed for member checking to ensure the interview data is in line with the intention of the participant. If there was uncertainty within the meaning of the text, it was clarified with the participant.

A topic guide, attached in Appendix A.2, was used as reference throughout the interviews. The topic guide was created with the methodological framework in mind which is used to answer the sub-questions and in turn, the main research question as well as lends itself to the codebook. Due to the nature of the study, depending on the actor interviewed, certain questions were more pertinent for specific participants than to others. Likewise, the topic guide leaves room for exploratory questions on the development of different technologies and influences to give the chance for the participants to highlight a topic or issue that may not have been identified prior to the interview.

Below in Table x, a table presents a description of the participants.

**Table 5: Participant Information.** The table provides information on the participants of the study, like their experience and how long the interview lasted.

Participant	Area of Expertise	Duration of interview	Date
Participant 1	Design of ethylene crackers expert	65 minutes	11/4/2023
Participant 2	System Integration Expert	50 minutes	14/4/2023
Participant 3	System Integration Expert Chemical Company	50 minutes	18/4/2023
Participant 4	Design of electric cracker  Product development	55 minutes	19/4/2023
Participant 5	Industry expert  Chemical company	55 minutes	19/4/2023

Participant 6	Researcher electric cracking	60 minutes	21/4/2023
Participant 7	Operation steam cracking Site integration expert	50 minutes	15/5/2023
Participant 8	System Expert Non-governmental organization	50 minutes	16/5/2023
Participant 9	Decarbonizing chemicals researcher	45 minutes	17/5/2023
Participant 10	Electricity grid New connection expert	50 minutes	19/5/2023
Participant 11	Chemical site & integration expert	50 minutes	23/5/2023

### Reflexivity and positionality

The obtained results like in all qualitative research is influenced by the environment of the participant and researcher. Considering the interpersonal nature of interviews, the answers of participants could be affected by the gender, age gap, nationality, and educational background differences between the research and the participant, as typically there was a gender difference, large age gap, and educational background difference.

Moreover, in attempt to support the validity of the results, triangulation of methods was used basing data on the interviews and literature review. To mitigate bias, questions were made to be open ended and while interviewing attempted to minimize the prescriptiveness in posing questions.

#### 3.3.2 Literature Review

Another method of data collection and analysis employed was through literature review. To answer each sub question, a literature review was performed. The literature was found through keyword search: 'SNM', 'Strategic Niche Management', 'chemical industry', 'chemicals', 'steam cracking' and more. The keywords were used on science direct and Scopus and searched in different combinations. This was also combined with going through citations and references from the studies themselves, leading to a snowballing effect of academic literature. Additionally, grey literature was also considered and operationalized.

The was policy papers, company press releases, patent filings, and industry convention papers.

A patent search using Espacenet and Google patent search engines for the key terms: “Coolbrook”, “BASF”, “SABIC TECHNOLOGIES BV”, “Shell”, “Electric olefin”, and more were used. As there are many patents by these companies, these terms were combined with “naphtha cracking”, “ethylene production”, “electric boiling”, etc. Another method was looking at the references within the patent themselves where they mention other relevant patterns, hence, the snowballing effect was also used in this method.

Lastly, another channel of literature review and data acquisition was through participants and industry experts who recommended or sent industry reports, literature, or policy to the researcher.

### 3.3.3 Coding

The interview data collected was analyzed in NVivo according to the Codebook found in Table 7. The table was created first deductively by using the Strategic Niche management framework, see Chapter 2 for more details on the theory. A deductive coding strategy differs from an inductive one since deductive code is derived from a theory while inductive is inferred from the data itself. The selection of category labels and coding units come from Verhees et al. (2013) where evidence of shielding, nurturing, and empowerment are provided. The inductive code comes from the data but also follows from the individual articulation of the socio-technical niche given by the participant. These topics were selected as they were influential in participants perspective and serve to highlight the differences in opinions of the participants.

The methodology section explains the research approach of this project. Starting with the case description, the system and its boundaries are explained. Next, the sub questions are addressed, and methods are presented. The semi-structured interviews were combined with a literature review of both academic and grey literature to provide a strong basis of analysis to the research. Finally, the coding of the interview transcripts is presented alongside the code book and code examples. This granularity allows for a thick description of data.

## 4 Chapter 4: Petrochemical Industry & Steam Cracking Technologies

This chapter addresses the first research sub-question on the developmental factors of the socio-technical system, starting with the industry composition and then continuing to the technical evolutions of the system. The different innovations are explained and presented with patents to indicate the similarities and differences in technological approaches. This chapter serves to address the first sub-question and as a basis to address the second and third.

### 4.1 Industry Composition

The chemical industry is a network of large multinational corporations. Leading companies compete in stiff competition for market share. This competition goes back many decades. Within the ARRA region, there are hundreds of companies working in cooperation to produce chemicals.

The industrial complex in the ARRA region has strong ties to each other. The pipelines show the deep-seated and structural interconnectedness of the area. The naphtha pipeline runs from Antwerp, BE to Geleen, NL. There are ethylene pipelines connecting Terneuzen to Geleen to Germany.

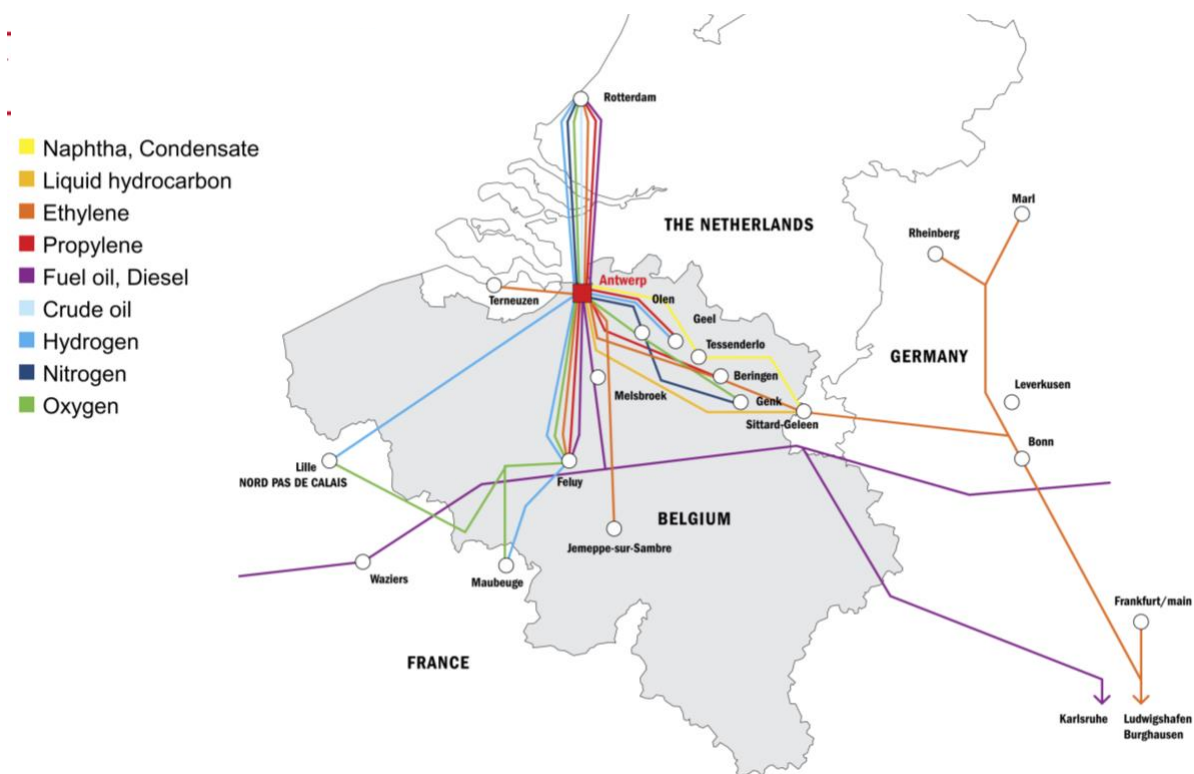

**Figure 7: Western European Pipeline Network.** This map displays pipelines linking different industrial clusters across the ARR region (Port of Antwerp, 2023).

This infrastructure is crucial for efficient and continuous transport of products between industrial sites. As shown in Figure 7, the transport of naphtha and liquid hydrocarbon are especially important as they are the prime feedstocks used in steam cracking in Europe, as noted above.

Janipour et al. (2022) recently studied the clustered nature of chemical sites and its effects on deep emission reduction. They used Chemelot, the chemical site in Geleen, NL, as their case study, where 150 companies are located (2022). The results of the study suggest that “clustering may hinder reaching deep emission reductions by three reinforcing feedback mechanisms, or ‘traps’, related to: incremental changes; short-term focus; and companies acting alone” (2022). Not only inter-sites but intra-sites, chemical sites maintain a large degree of interdependencies. A good example of this is the steam network found at Chemelot, as seen in Figure 8.

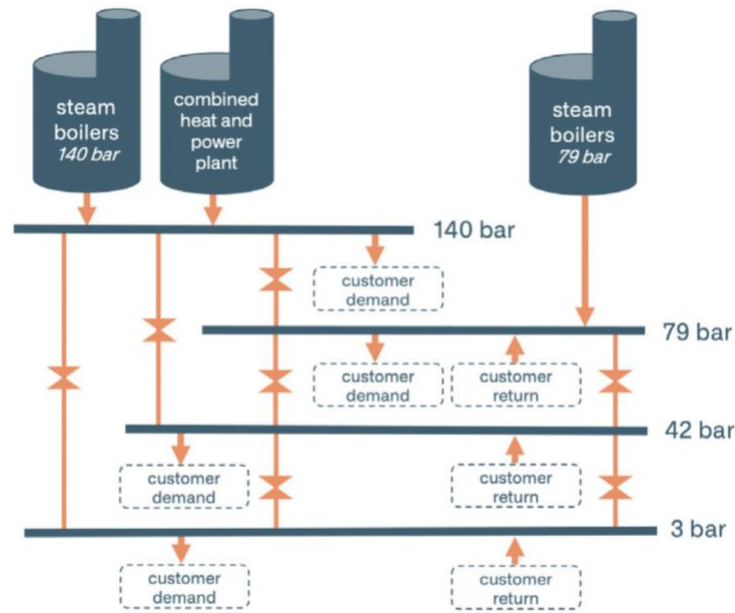

*Figure 1: Impression of the steam system Chemelot (simplified view)*

**Figure 8: Chemelot Shared Steam.** This figure shows how a chemical site, here, Chemelot, increases efficiency by acting collectively, contributing to and using a shared steam network (Brightsite, 2020).

Within the site, while some companies produce more steam than consumed, the inverse is also true allowing steam generation to be managed at a site level instead of by company.

Thus, at the site level, the lesson learned from Janipour et al. (2022) suggest that efficiency can be improved, if managed systematically. This could also be supported by the Prisoner’s Dilemma which is exaggerated by the existing infrastructure and interdependencies.

### European Market Trends

The challenges facing the European chemical market require serious coordination and planning to ensure a future proof industry. The global market share of the EU chemicals has nearly halved over the last two decades as seen in Figure 9. While the overall sales have increased through the years, the heightened electricity and gas prices have persisted causing concerns for producers and the overall performance of the industry.

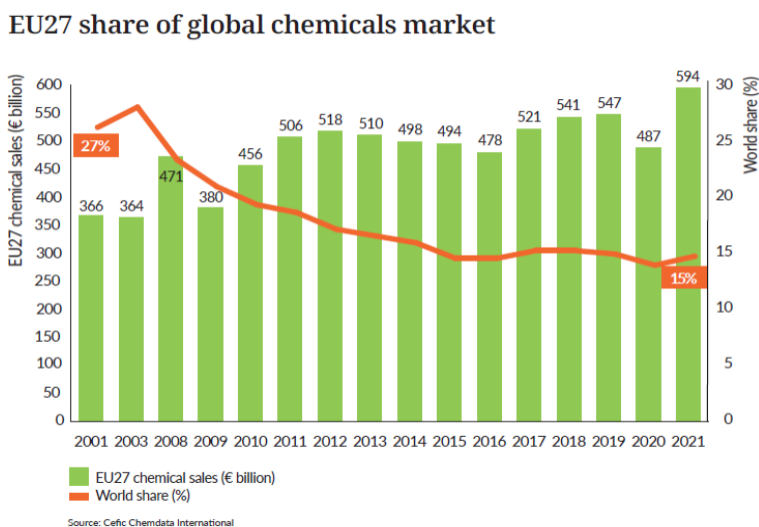

**Figure 9: EU27 Global Market Share.** This figure shows gives an overview of the chemical sales over the past two decades in pure quantity and percent of market share. The market share of Europe has halved while still growing overall. (Cefic, 2023).

It has been more than 25 years since new steam cracker sites were built within Europe but with expected demand of ethylene to increase in the future even in light of environmental goals, there is a new push for carbon efficient crackers. A new cracking site drive by Project One in Antwerp inaugurates a new commitment to cleaner olefin production. This can help Europe capture more market share and continue production on the continent itself.

With high feedstock costs and electricity prices experienced over the past year, there seems to be a return to a steady price in crude oil. As ethylene depends on naphtha and other crude oil distillates, the feedstock price effects the utilization rates of plants and therefore the production rates which effects the overall market share. Figure 9 depicts the price differences between regions over the last ten years. Europe has consistently

outpriced North America and the middle east with the difference growing more pronounced since 2020. This as explained before is tied heavily to landscape developments and increases in the OPEX.

**Ethylene cash cost of regional steam crackers, US\$/tonne C2**

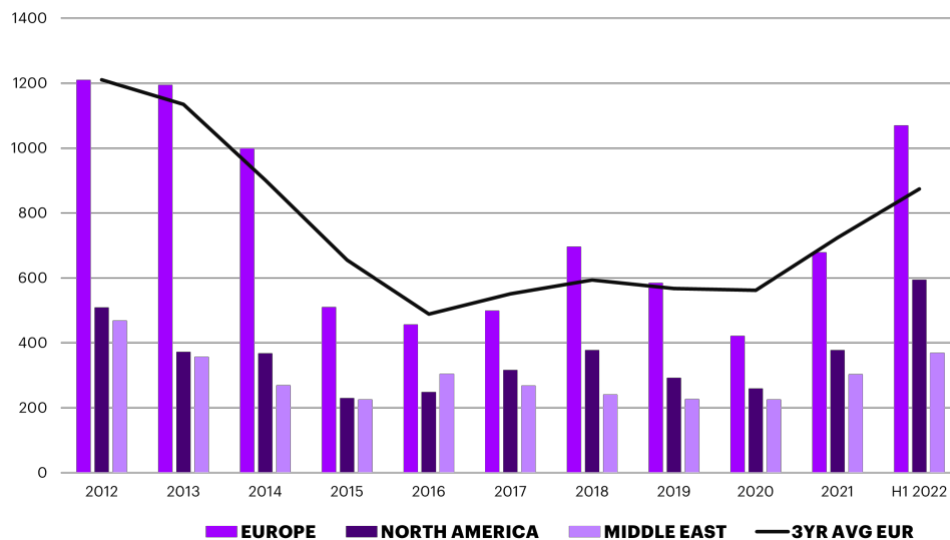

**Figure 10: Ethylene Cost by Region.** This figure compares the regional costs of operating steam crackers between Europe, North America and the Middle East. Europe is always significantly more costly. Adapted from (Cefic, 2023).

As mentioned previously, multinational companies both maintain the status quo to protect the current profitable modus operandi and invest in research and development. Bauer & Fuenfschilling (2019) characterized the chemical company as dominated by incumbent actors aimed to make incremental improvements. The price for new entrants is more often than not inaccessible because of the large capital required, the strong competition, and high knowledge required.

#### 4.2 Technologies Available

This section presents and explains the main different routes to crack feedstock. There are more methods that are under research, such as using plasma. First, the traditional steam cracking is described; after which, three methods to cracking are explained. The most technically innovative, shockwave pyrolysis, comes first, followed by a description of resistive and inductive heating, then a review of oxyfuel, the closest to the conventional technology, and lastly, a look at improving existing equipment. Overall, advancing new methods require an immense amount of research and engineering. The advancement in



kinetic (computer) simulation techniques could lead to greater and quicker understanding of these methods.

Historically, many pathways for improving or alternating steam cracking have been researched. For example, oxidative coupling of methane (OCM) has been studied intensely as an alternative to steam cracking. Instead of naphtha, methane is used as feed; high temperatures and pressures force the thermodynamically stable methane into longer hydrocarbons (Ortiz-Bravo et al., 2021). However, this technology is expensive and not yet cost competitive with steam cracking. This is due, in part, to the fact that its product is thermodynamically limited, meaning it yields less ethylene compared to traditional methods (Cruellas et al., 2019). However, as Europe endures high methane prices, OCM becomes less economically viable, even in light of it producing fewer emissions than steam cracking. Because steam cracking emission and energy intensity is high, it is imperative that the current, well-established technology is substituted with methods which uproot the need for fossil fuels, whenever and wherever possible. A recent study by Tajani et al. (2022) summarizes the alternative electrification routes available to cracking technologies. First, a literature review on Arc/plasma cracking is presented. While it is mainly used to produce Acetylene, it also produces ethylene (Tijani et al., 2022; Ganieva & Timerkaev, 2016). Ongoing research shows promising lab results for production of ethylene, however, thus far, the results have only been achieved in the lab. Overall, there are a handful of alternative dominant routes that have emerged from research. First, that is using shockwave pyrolysis, followed using resistive materials either directly or indirectly, and lastly is altering burners and fuel compositions and adding additional transfer line exchangers (TLE).

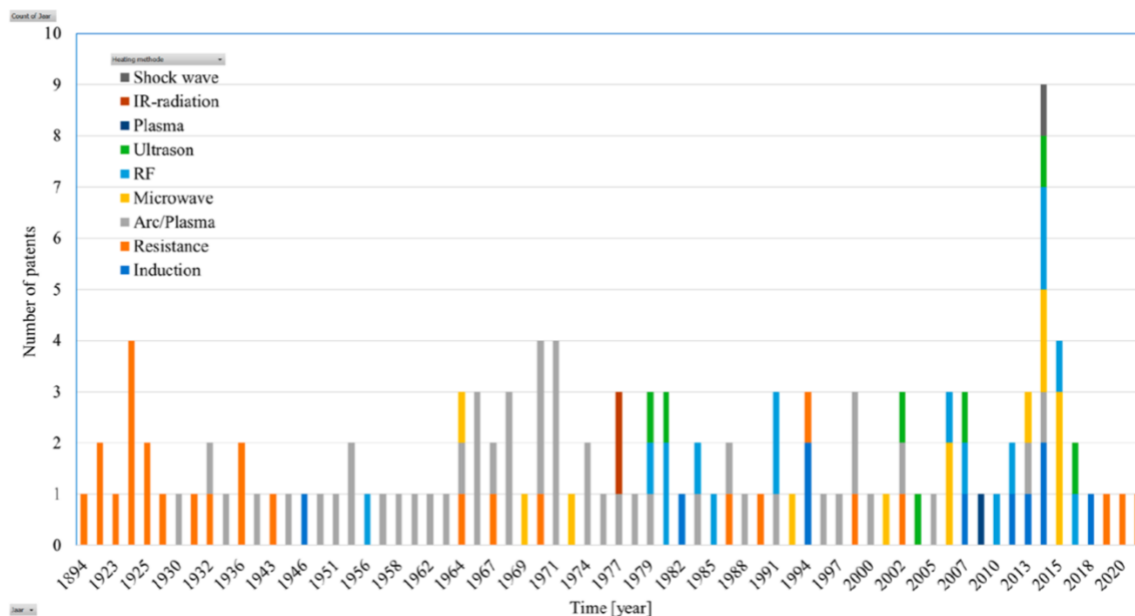

**Figure 11: E-cracking Patent Results.** This figure by Tijani et al. (2022) shows a patent review on cracking technologies, not limited to only steam cracking.

Steam cracking has been in the public domain for nearly 150 years and has been studied by countless researchers in that time. In Figure 12, the patent research performed by Tijani et al. (2022), depicts the different patents published on different technologies (2022). This review also includes the use of arc/plasma and technologies to crack other than just naphtha. However, the parameters for the patent review are not described. According to this figure, shockwave technology first appeared in 2015, however, earlier patents on the fundamentals of the technology, date back to 1999.

#### 4.2.1 Conventional technology

Operating a steam cracker is an extremely complex process, and the traditional cracking method is no exception. There are complex and highly reactive chemical processes taking place simultaneously and considering the scale of the operation, highly flammable materials are heated to temperatures of up to 1100° C degrees. This creates an environment in which safety must be the number one priority and a strict operational understanding and awareness is the only way to ensure this. This section presents a simplified explanation of naphtha steam cracking to provide a bases to understand the innovations offered by new technologies and to understand the inherent difficulty in

altering the conventional ethylene production methods, due to the complexity and sheer magnitude of the operations at these chemical sites.

Figure 13 contains the various reactions that occur within the reactor. They are segmented into four categories: initiation, propagation, termination, and disproportionation. These are the typical processes of a radical chain reaction which occur when the feed is cracked without a catalyst (Ren et al., 2006). As can be seen, hydrogen and methane are products of the propagation reactions. Hydrogen and methane constitute about 10-15% of the by-products created by the process.

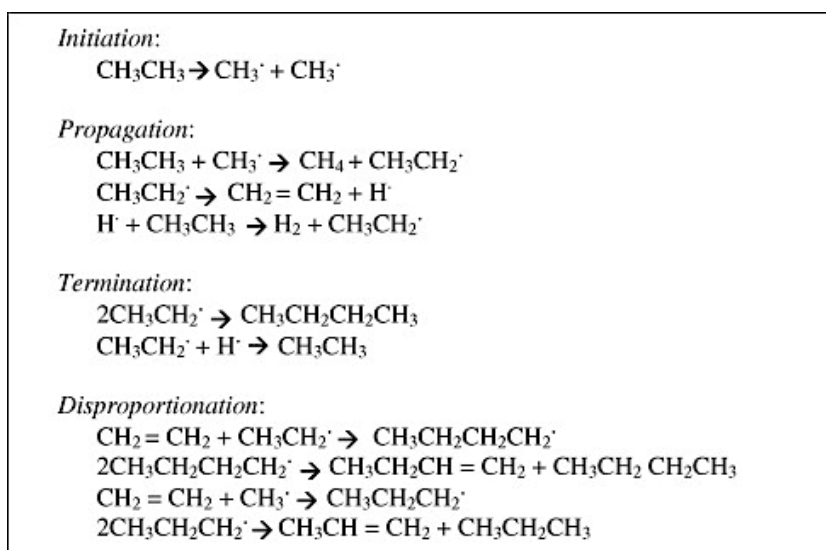

**Figure 12: Steam Cracking Reactions.** This figure lists and characterizes the reactions within the steam cracker's reactor (Le Van Mao, et al. 2013). The main product  $\text{CH}_2 = \text{CH}_2$  occurs in the propagation phase. It is important to quickly quench the hot feedstock mixture to avoid unwanted other products.

Following Figure 13, the feed comes into the reactor and is pre-heated in the convection section, heating it up to temperatures of 650° C (Ren et al., 2006). It then is infused with superheated steam, called dilution steam. The primary function of the dilution steam is to reduce the partial pressure of the feed which lowers the heat required to drive the ethylene. The feed then makes its way to the reactor's radiant section. There, it has an extremely short residence time, on the order of milliseconds (0.2-0.4s), where it is to temperatures between 750°- 900°C (2006). Ethylene synthesis is more likely to happen in high temperatures and with low residence times (Raseev, 2003). The hot effluent leaves the furnace and undergoes a series of quenching steps in transfer line exchanges (TLEs), which reduces the probability of additional undesirable reactions occurring. Typically,

temperatures are between 550°- 650°C, but can be lower as low as 400° C, after the TLE (Ren et al., 2006; and Rossi et al, 2019). In the TLE, heat in the effluent feeds is transferred to steam in order to drive the compressors and preheat the dilution steam.

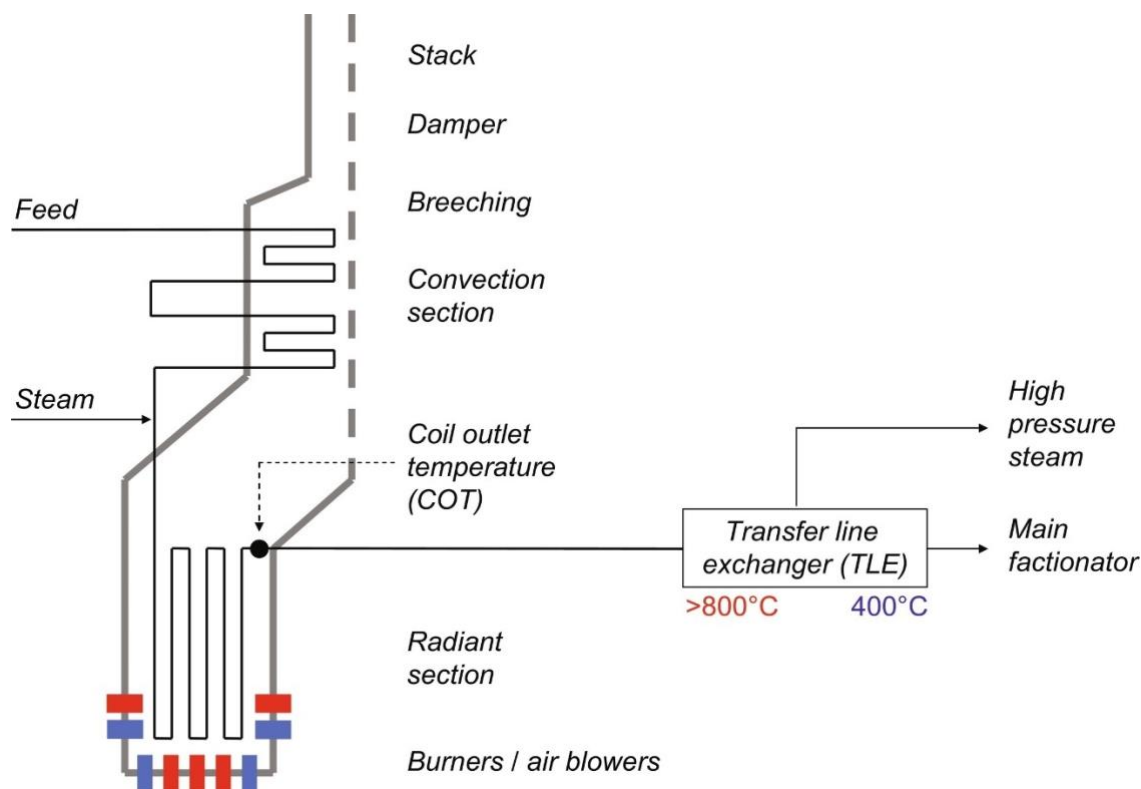

**Figure 13: Conventional Steam Cracker Diagram.** This figure depicts a side view of a steam cracker. From it, the flow of fuel and steam can be seen as well as the main components of the reactor. Source: Rossi et al. (2019).

After quenching, the cracked gas goes to the primary fractionator. Here water and fuel oil are separated out, as well as aromatic gasolines, such as benzene, toluene, and xylene. After this, the feed is handled in low temperature environments, as seen in the name of this area of the plant, appropriately called the “cold section.”

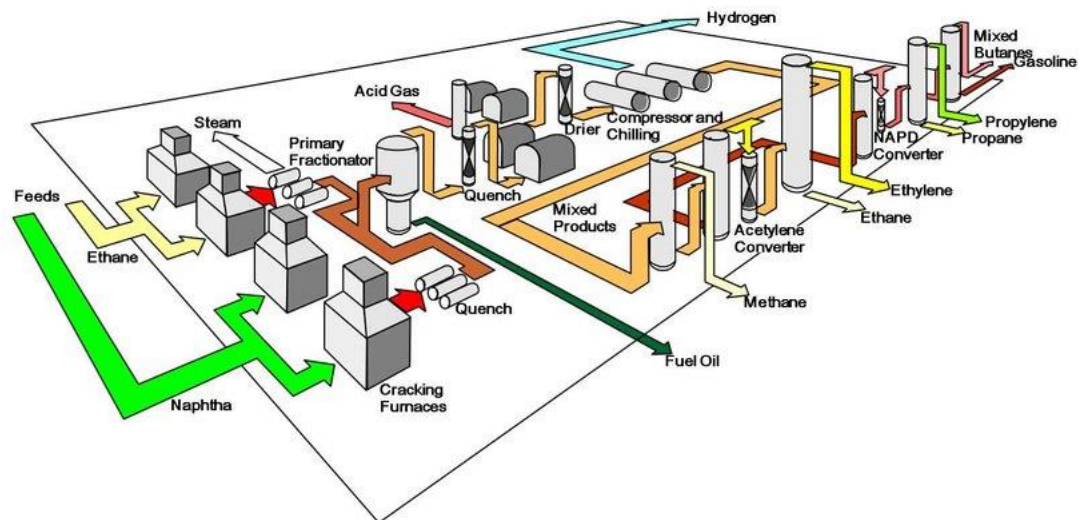

**Figure 14: Ethylene Plant.** This figure contains a schematic of a traditional ethylene cracking site (van Goethem, 2010). The feedstock enters on the left are cracked and continue onwards for further processing. After quenching, the primary fractionator separates out certain products. Then, the products continue onwards to the cold section to be cooled and separated into the individual product streams.

The function of the cold section is important; it is here that the separation and recovery of products takes place. As seen in Figure 14, there are a series of steps to separate out the different products. The “cold section” is not a misnomer: temperatures here are between  $-150^{\circ}\text{C}$  to  $-10^{\circ}\text{C}$ . The pressure requirements in the different steps are also significant: high pressures of 15-30 bars. (Ren et al., 2006).

The process happens continuously, with downtime occurring regularly to decoke both the furnaces and coils. According to Ren et al. (2006), decoking in naphtha crackers takes 20-40 hours and must occur every 14-100 days, typically erring on the side of more frequent decoking, than not. This is a known operational requirement. It results in at least one furnace being out of commission for maintenance at a site, while the others remain in use.

Naphtha crackers produce large quantities of products with the average capacity of a European cracking site producing 533 kilotons of ethylene per year (Cefic, 2021). This production level requires an equally large amount of feedstock with an average volume per furnace rising above 100 kilotons per year (Kusenberget al., 2022). According to a PBL-TNO, the SABIC steam cracker unit in Geleen, NL follows on this demand and uses Naphtha and various recycled feeds of ethane, propane, and others from gasoline production as a feedstock (Oliveira & van Dril, 2021). Moreover, it requires approximately 31.2 PJ/year including pyrolysis, compression, fractionation (Oliveira & van Dril, 2021). Another study

calculated that it takes 22.4MJ of primary energy to produce a kilogram of ethylene and emits 1.44 GHG kg CO<sub>2</sub> equivalent (Negri, A., & Ligthart, T., 2021).

#### 4.2.2 Shockwave

This section presents the older version of shockwave pyrolysis and the newer, turbo-reactor based. Fundamentally, shock waves occur when there is a switch from a Mach below one to a Mach above one, through a fluid. This means that there is a switch in a fluid's velocity, from subsonic to supersonic, thus creating a series of pressure waves which merge into a shock wave front, where a near instantaneous change in thermodynamic parameters occurs. This could be induced by a nozzle injecting streams into a mixing chamber at supersonic speeds, which then causes disturbances to the flow, thereby creating shock waves. Shock waves can heat reactants to temperatures >800 °C on the order of milli seconds (Tijani et al., 2022). Traditionally, this process makes use of a reactor called a shock tube in which a driver and test section are separated by a diaphragm, as can be seen in Figure 15 (Bhaskaran & Roth, 2002). The diaphragm ruptures, releasing a propagating shock wave through the test section and a rarefaction wave through the driver section. The pressure and temperature jump with each crossing of a wave front, thus creating the thermodynamic conditions to crack the feedstock.

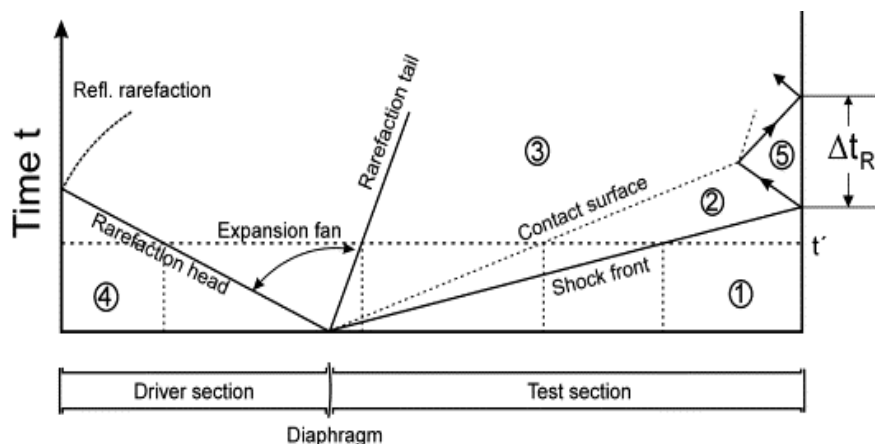

**Figure 15: Shockwave Pyrolysis Diagram.** This figure is a position time graph, representing a shock tube or a reactor using shockwaves. On the x-axis, the length of the test reactor is shown, while time is plotted on the y-axis. A shock wave travels across the test section, as does a rarefaction wave. These shock waves cause a jump in temperature and pressure within the reactor (Bhaskaran & Roth, 2002).

This linear reactor design is the conventional approach to this type of pyrolysis. There are academic studies dating back to the 1970s (Fussey et al., 1978); (Treanor et al., 1982), and patents from the 1990s on the mechanics of shockwave pyrolysis (Hertzberg et al., 1993). In Figure 16, the supersonic mixing chamber can be seen in the patent diagram. The hot

carrier gas enters the supersonic mixing area where the feedstock and carrier gas are then brought up to similar temperature conditions. Label 42 shows the location of the shockwave emergence which propagates into the area labeled 40. This provides the pressure needed to drive the increase in temperature. It is at this stage that the conditions are reached that are required to crack the feedstock from ethane to ethylene.

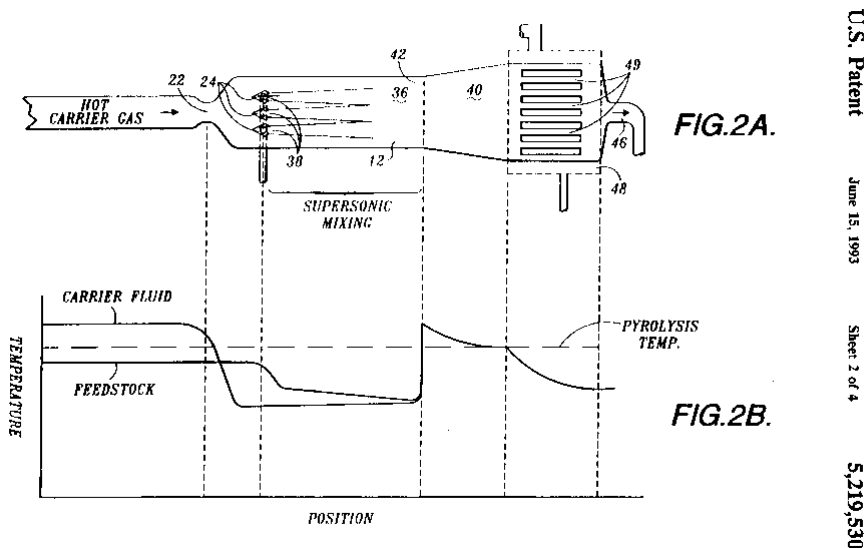

U.S. Patent  
June 15, 1993  
Sheet 2 of 4  
5,219,530

**Figure 16: Shockwave Pyrolysis Patent 1993:** These two panels depict a patent filing of the shockwave pyrolysis (Hertzberg et. Al., 1993).

Despite the longevity of the research domain, there are few commercial operations available making use of this pyrolysis method for ethylene production. However, a novel design has been introduced most notably from Coolbrook, with the aid of various universities and partners, called the Roto-dynamic Reactor (RDR).

The Rotodynamic reactor is an innovative turbomachine that offers a route to electrification for steam cracking. However, this route is dependent on the infrastructure being present at the site to provide the required electricity for correct operating conditions. Unlike the linear (and cylindrical) pyrolysis described above, the RDR is turbomachine, resembling a toroidal reactor. It can reach temperatures as high as 1100 °C (Rubini et al., 2021). Powered by electricity, it aims to revolutionize steam cracking without using fossil fuels as a direct heat source. The significance of the turbomachine approach is that the electricity consumed by the RDR, if coming from renewable sources, would have no associated emissions in the heating process, and in fact, it would create a surplus of fuel gas and methane. The surplus would occur because the RDR no longer consumes fuel gas

or methane to reach pyrolysis temperatures. At the same time, beyond the reduction in emissions, the reactor allows for additional benefits like diminished coke depositions, increased ethylene yield, and more control over the reaction mechanics while in operation (Rubini et al., 2022).

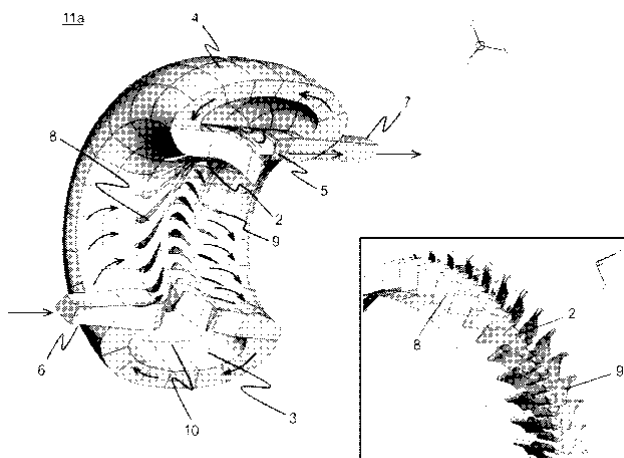
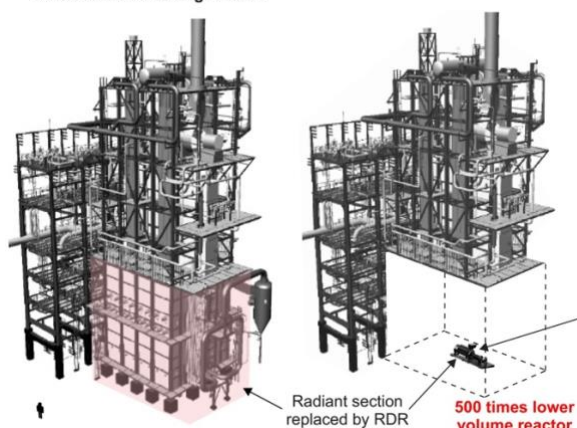

Figure 2A  
Conventional cracking furnace



**Figure 17: Roto Dynamic Reactor.** The top figure shows the Rotodynamic reactor from Coolbrook, featuring the innovative curved blades allowing for high levels of control (Seppala, J. et al., 2016) The bottom figure shows the difference in size between the RDR and a conventional furnace (Rubini et al., 2022).

As mentioned before, the endothermicity of the feedstocks dictates the energy requirements of a furnace. However, the key to electrifying this process is the presence of a reliable source of electricity on the order of hundreds of MW. That is a substantial requirement. According to the cluster energy strategy of Chemelot (Chemelottaffel Klimaatakkoord, 2022), there is an expected power requirement of 800MWe for electric



cracking. Moreover, a publication from Shell and ISPT (2021) indicates that the Netherlands has 4000kta of ethylene crackers which requires an annual energy consumption of 28 TWh.

Besides Coolbrook, Technip Energies and Siemens Energy are working together on a rotating olefin cracker, called an eFurnace. As recently announced in June 2023, it will be demonstrated at a plant in Texas (Technip Energies, 2023).

#### 4.2.3 Direct & Indirect heating

This section explains another alternative to conventional steam cracking. In this method, electricity is used either directly or indirectly, typically via the joule effect. The direct method applies electricity to the pipes directly which begins heating. The hot pipes heat the feedstocks. Meanwhile, the indirect heating makes use of an intermediary material to transfer heat to the pipes with feedstock flows or uses induction to heat the feedstock.

In Figure 19, an electrically powered furnace is shown. This represents an indirect, resistive heating method. The set-up of the furnace could be as follows. The row of tubing forms a matrix with every row alternating between heating elements (RE) and feedstock tubes (RT).

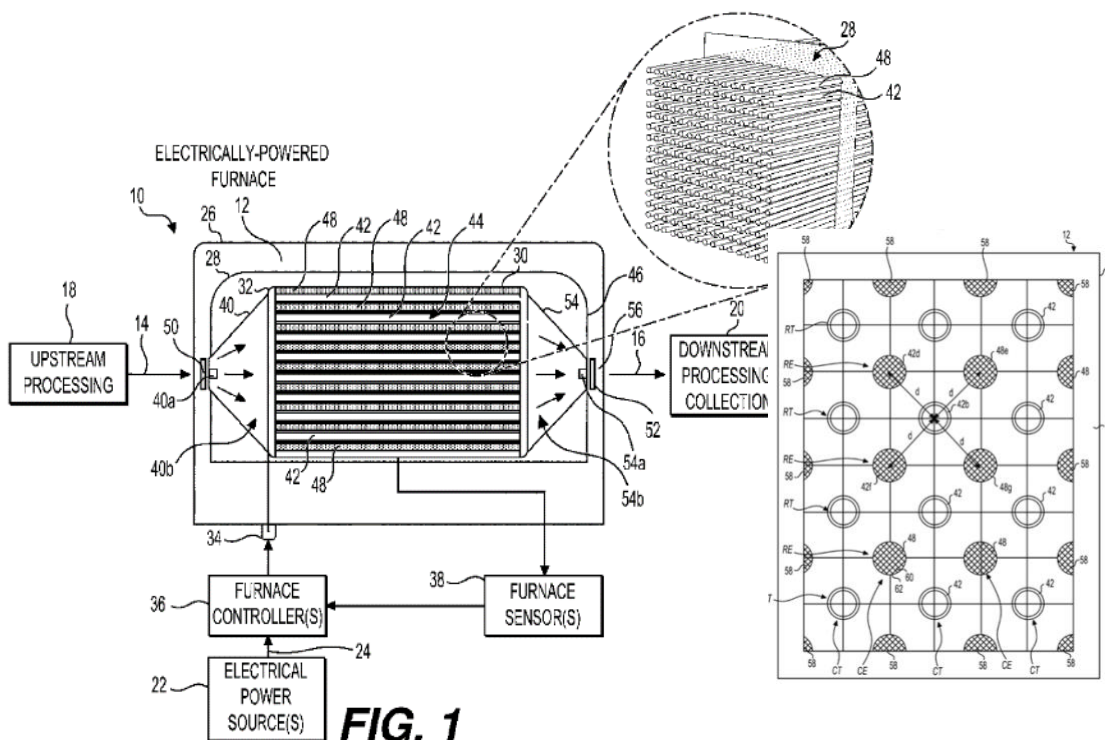

**Figure 18: SABIC Electrically Powered Furnace.** This shows the diagram for an electrically powered furnace. The feed comes in from the lefthand side and into the tubing. Both figures come from the patent (cite). The

series of tubes have an alternating pattern of tube being a heating element (RE) and the tubes filled with feedstock (RT) (Stevenson, S. et al., 2023).

Figure 20 depicts an inductive heating method. The wire wrapped around the tube, aka the induction coil, has a large current high frequency alternating current, on the order of a 1000 Amperes, running through it, inducing an alternating magnetic field and eddy currents to generate heat. Moreover, the insulation (117) reduces heat losses.

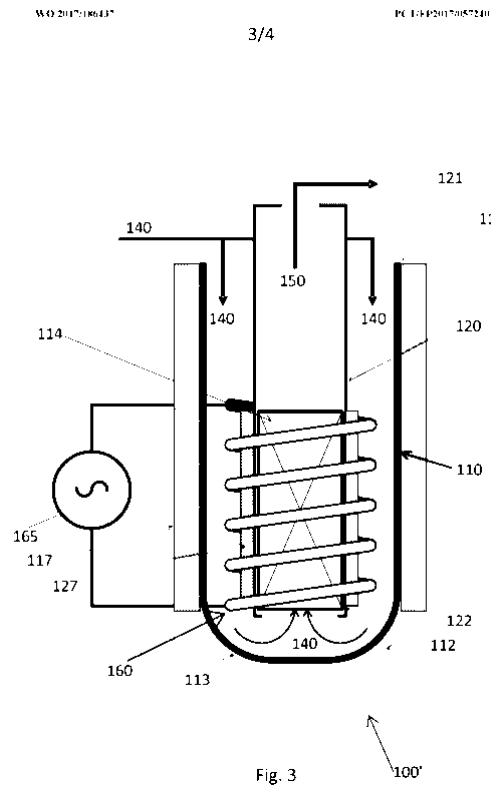

**Figure 19: Induction Heating Patent.** These two panels depict the patent diagram from a patent (Mortensen et al., 2017).

#### 4.2.4 Oxyfuel & Improved TLE / system improvements

In 2022, Technip Energies published their “Novel Low-emission Ethylene Plant”. In the publication, they detail three steps towards low emission cracking, taking a series of steps of replacing fuel gas with green hydrogen and partial electrification. This was developed partially under the IMPROOF project from the EU in collaboration with other partners. The novel furnace provides a route to reduce emissions by 30%.

In the first stage, the plant aims to make better use of the excess fuel by firing it to generate additional electricity to cover the consumption of newly installed electro-motors in place

of steam condensing turbines. The following step details installing a storage for the excess fuel to use when renewable power is not available. Lastly, the third step is to run the crackers on green hydrogen allowing for the export or use of the fuel gas.

The low-emission principles behind the new furnace are to reduce the scope 1 emissions by directly integrating hydrogen and optimizing material flow streams. The feed-effluent type primary transfer line exchanger is Technip Energy's innovation to keep radiant coils at the required temperatures. The power generation of a conventional ethylene plant is 18.5MW and considering a stage 3 configuration, has a power generation of 39.2MW (van Boekel and Oud, 2021). This creates another branch of possibility for flexible operation. Moreover, the use of a low carbon emission furnace will use the extra fuel gas saved and require a steam methane reformer plus a carbon capture unit.

All these pathways are possible and being actively explored. Another notable route to produce ethylene is using a plasma conversion technique. This is still under research but at the moment, seems to be a promising lead. However, it is estimated to be ready around 2040 and is beyond the scope of this report.

#### 4.3 Policy

This section aims to give a concise overview of the policies mentioned as influential during interviews. These policies have influenced the chemical industry and the research, development, and innovation that it has been able to produce. Such efforts have a shielding, nurturing, and empowering effect.

First, the Dutch National Climate Agreement (KIA) has set out for the Netherlands by the end of the decade (by 2030) to nearly half emissions compared to 1990 levels. It predicts "70% of electricity production" to be based on weather. This is likely to create seasonal and daily production patterns that could affect the pricing and the integration of electricity consuming technologies. Furthermore, this climate legislation sets out detailed mechanisms to spur research and development of innovative technologies, specifically dedicating public funds for roadmap development, hydrogen use, and CCS & CCU and more.

Miek (Meerjarenprogramma Infrastructuur Energie en Klimaat, in English - Multi-year program of Infrastructure, Energy and Climate). The MIEK is based on the CES (cluster energy strategy). MIEK focuses on industry and claims to be in line for the largest reduction of CO<sub>2</sub>.

## **Subsidies**

The MOOI subsidy is aimed to fund projects to reach the Dutch Climate Agreement and stands for Mission driven Research Innovation and Development. The terms to be eligible stipulate that more than 3 parties must be involved, and it must have a max budget of €4 million (RVO, nd). Likewise, the DEI+ stands for Demonstration of Energy and Climate Innovation. This covers cost for demonstration and pilots for technologies to reduce CO2 emission and can be requested until August 31, 2023 (RVO, nd.). There are multiple categories that are eligible from local infrastructure to circular economy. The NIKI is aimed specifically for Industrial investment projects to again reduce CO2 emissions. It provides funds specifically to facilitate the industrial transition. SDE++ is a subsidy package targeted at stimulating Sustainable Energy production and climate transition. It is another package which allows for government funds to focus on development and implementation of sustainable energy technologies. WBSO is a subsidy based on tax credits for the research and development which is not limited to sustainable energy and has been in effect since 2015. These act as pre-existing policies which protect the niche, allowing it space to continue learning.

Another subsidy available that was not mentioned during interviews was the MIT subsidy which stands for Mkb-innovatiestimulerend Regio en Topsectoren. This focuses on stimulating innovation for medium and small companies. It can be for actually technology research but also for network building activities which is beneficial.

## 5 Chapter 5: Steam Cracking: Protective Space Analysis

This chapter aims to do three things. First, beginning with actors that are prevalent within the socio-technical regime and niche, it illustrates who is active within it and who historically has been. Secondly, the processes of shielding and nurturing are addressed considering the data collection and the articulation of the niche is presented according to the actors. Lastly, empowerment strategies are provided based on interview results. This addresses up to the fourth research question.

### 5.1 Actors

Actors were an important theme throughout the data analysis portion of the study. In table 7, the actors mentioned during interviews are listed and categorized based on their role. The story of how electrified steam cracking has evolved within the Netherlands will be partially told here while addressing research sub-question #2 in this section.

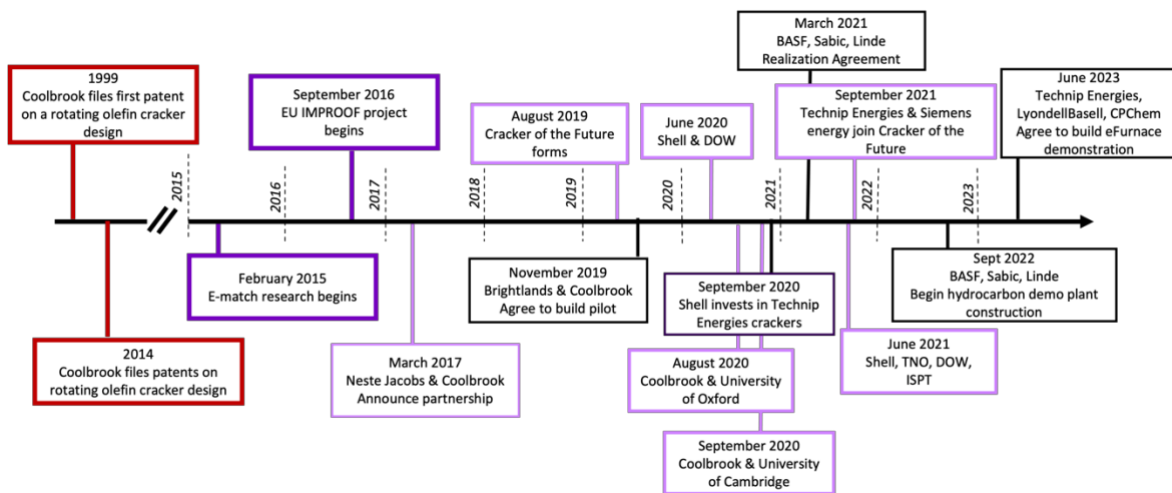

**Figure 20: Actors Timeline.** This figure contains the information published by companies and research organizations on joint ventures, agreements, and some patents. This aims to help characterize the network typology chronologically in the ARRA region.

In Figure 20, the public announcements of partnerships is shown. The patent landscape is not fully shown as the focus is on the network collaborations. Throughout this figure, the role of universities is to provide support in modeling and research. This is most strongly shown by Coolbrook's routine partnering with university labs like with University of Oxford and University of Ghent.

**Table 6: List of Actors.** This table contains the actors mentioned in interviews according to their category and role in the system.

<b>Actors</b>	<b>More specific</b>	<b>Name of organization</b>
Industry	Chemical companies	Shell
		Dow
		Sabic
		Braksem
		Air products
		SNOOC
	Technology Developer	BASF
Technip Energies		
System Managers	Electricity grid	Coolbrook
		TenneT
	Material Provider	Stedin
		Port of Rotterdam
	Gas grid	GasUnie
Site Facilitator	Brightsite	
Governmental Agency	Dutch Level	Authority for Consumers and Markets
		Ministry of Infrastructure and Water
		Ministry of Economic Affairs
	EU Level	EU Commission
		EU Parliament
Research	Universities	Utrecht University
		University of Oxford
		University of Ghent
		Aachen University
	Institutes	TNO
		ECN
		Voltachem
Non-governmental agency	Dutch	Natuur & Milieu

Next, there are a handful of local niches identified within the Netherlands. They are described below. The project or company is given as a subtitle and a description of actors involved and context is provided. This helps to contextualize which actors are prominent in experimentations.

### **E-Match Project**

The earliest collaborative effort found during the (grey) literature review is on the E-match project from Voltachem which is a spin off focused on electrifying chemicals from TNO. Starting in early 2015 and ending in 2018, it researched the potentials to implement Power to X: heat, hydrogen, and chemicals within the Netherlands. Partners in the E-match program included: Voltachem, OCI Nitrogen, DOW, AkzoNobel, Stedin, and Arkema. As an end deliverable, it provided a report on the readiness and fit for multiple domains of technologies as well as providing a roadmap and an innovation sciences traditional “forecasting” providing a vision for the future, as seen in Figure 2. Likewise, working with the main stakes holders, the project was able to provide an in-depth (confidential) report on electric cracking.

### **IMPROOF:**

This project aim was to reduce the environmental impact of steam cracking. This was a research fund granted by the EU and allotted 7 million euros to facilitate the studies and interactions between participants. The goal was to help sponsor new furnace designs that achieve the GHG reduction and especially a NO<sub>x</sub> reduction. The actors involved include University of Ghent, Technip energies, and more. A new furnace design was brought to market by Technip Energies because of it.

### **Coolbrook**

Coolbrook, based in Finland and the Netherlands, is developing a rotational olefin cracker as detailed in section 4.2.2. The founders first registered patent dates back to 1999 and more recently, in 2014, it began patenting the rotational olefin cracker that became the design prototyped today, the RotoDynamicReactor. The company aims to commercialize its novel reactor by 2024 which could result in “500 Mt of reduction potential in chemicals and petrochemical industries” (Coolbrook, n.d.). Since Coolbrook was a startup experiencing intense regime selection pressure, it chose to forge numerous partners both industrial and research based. Coolbrook’s website details the company’s plans to develop the network around its technology, including “partnering with industrial actors, EPC partners, and universities for successful piloting,” as well as engaging with customers (Coolbrook, n.d.). Likewise, the multiple partnerships can be seen in Figure 20.

### **Technip Energies:**

Technip Energies' specialty is the design and manufacture of complex machinery and systems for industrial processes. They offer two routes to (partially) decarbonize the ethylene production. First and closely tied to the final deliverables from the IMPROOF project, they designed a very low carbon furnace that provides up to 30% decrease in carbon emissions, though this research and development predates the IMPROOF project. Additionally, Technip Energies is partnered with Siemens Energy in its product offering, the rotating olefin cracker, or e-Furnace for short. This furnace is very similar to that of Coolbrook and provides a similarly (near) path breaking innovation. The benefit of the low carbon emission furnace over the eFurnace is that it has been on the market longer and requires less risk as the eFurnace creates a large dependency on system infrastructure like access to high quantities of electricity.

### **Crackers of the Future Consortium:**

This consortium emerged officially in 2019 and was composed of regime actors. A large industrial partnership consortium came together, focused on creating a new steam cracker. Borealis, BP, Total Energies, LyondellBasell, Repsol, and Versalis joined forces to create the "cracker of the future." Together, they want to electrify a steam cracking furnace and should have a demonstration plant constructed sometime in 2023 (Cefic, 2022). BASF, Sabic, and Linde have also come together on a joint project. Theirs is at the Ludwigshafen Verbund site in Germany, where a 6MW electric cracker will enter the demonstration stage in 2023 (Sabic, 2022).

### **E-mission MOOI**

Another consortium is the E-mission MOOI Project, which is a collaboration of the Dutch research institute TNO, DOW, Shell, and ISPT (Institute of Sustainable Process Technologies). This is a four-year long project and aims to investigate both short term and long-term solutions to reach CO<sub>2</sub> neutrality in 2050 (TNO, 2022). Finally, a patent search revealed that Technip Energies is also working towards electrifying a steam cracker and even hopes to use hydrogen in its steam cracker. Interestingly, in one of their reports, Technip Energies claims that they are working to electrify machinery, as opposed to simply using additional steam to drive furnaces (Technip Energies, 2022). All of these partnerships represent emerging systems around novel technologies, each with a large potential to eliminate the use of fossil fuels to meet the enormous heating requirements of the cracking process. To understand how these systems are developing within Europe, an innovation sciences investigation into the niche management should be performed.



**Shell:**

Shell is a strong regime player of the chemical industry and is certainly active within the niche as well in the Netherlands. The Energy transition Campus in Amsterdam allows for key proximities to be achieved in terms of cognitive, geographical, and more with the other actors. Importantly, in 2018 Shell committed to improving their furnaces in an agreement with Technip energies where 8 furnaces will be added and substituted in at the Moerdijk site though these are not stated to be electric crackers. While this is scheduled to finish in 2025, it could mean additional lock-in to conventional fuel-based approach to steam cracking. The aim of the upgrade is to reduce scope one emissions by 10%.

**Chemical Clusters:***Port of Rotterdam (Moerdijk, Terneuzen)*

In the Port of Rotterdam's industrial cluster report from 2021, it mentions the use of electric cracking at the site. It mentions that TenneT is conducting an exploratory research phase, referred to as "quick scan." The timeline from when a scan is request to when the actual upgrade or implementation is made as explained by an interviewee, can take up to 7 years. This means increasing the access to the systems grid via 150kV extensions and a new 380kV substation at Moerdijk (Port of Moerdijk, 2021). In 2022, it aims to via direct electrification the Port of Rotterdam aims to reduce emissions by 1 Mton (assuming CO<sub>2</sub>-eq, since its not mentioned). Moreover, it plans on connecting an additional 5.7 GW of capacity from the North Sea until 2030.

*Chemelot*

Like the Port of Rotterdam, Chemelot must also transition. It faces similar electricity constraints but has less of a focus on electrolyzers than the port of Rotterdam. SABIC is situated on the Chemelot campus and within the cluster energy strategy of 2022. A timeline is not assigned to the electric naphtha crackers. Though a total amount of 800 MWe is, in steps of 400MWe. Only 2 naphtha crackers were mentioned in the CES. The effect of electrification on medium and high-pressure steam is being sorted by Brightlands now.

## 5.2 Shielding

Under the shielding category, there were a variety of codes used to identify artefacts of this form of niche protection. A significant factor in electric steam cracking's development

has been due, in no small part, to the government's interest in innovation. Favorable policies and subsidies for technological development have contributed to the fostering of the socio-cognitive evolution process within the Netherlands.

The pre-existing support, as mentioned in Chapter 2, is a form of shielding which provides protection and allows the niche to develop. In the Netherlands, there have been subsidy schemes that support research and development of new technologies in general. Moreover, the push for technologies to be demonstrated is also supported financially by a subsidy scheme. The pre-existing support can be considered on different levels from subsidy to geographical protections. Thus, in asking participants to consider why the Netherlands has more research and development of this technology than other countries, the participants were given the chance to interpret the question broadly to share insights into how the Dutch support system has aided development and what is valued in it. Notably, participants were also given the chance to explain what else is needed in terms of support and often, more subsidies were mentioned. Nonetheless, previous support schemes have played a role in creating a protective space for development.

### **Subsidies**

While participants mentioned the need for additional subsidy and governmental support, participants also outlined how their technology system has benefited from the Dutch support system. Subsidies are available for general (and innovative) research and development (WBSO). These are tax credit-based subsidies. As such, they have proven effective at providing funding for the research and development of new technologies. As a passive form of shielding (Verhees et al., 2013b), it is of particular help to actors with less access to resources, giving them the support, they need in the socio-cognitive process of continued variation. Thus, it also supports the retention of global niches and collective learning. Similarly, it gives actors and agents the financial incentive to make their ideas a reality and develops the technology further. This is exemplified from a comment of a participant who works in the technology development and mentioned that WBSO where the hours spent on a topic are funded if you ask upfront. This allowed for additional funding and tax deductions to be granted for those hours spent researching and developing.

Moreover, the utility of this support is explained by a less powerful actor who is a technology developer:

*The Netherlands has a good, let's say, subsidy climate. So that means that we from the government, we have received almost 50% of the of the construction costs as a a subsidy. And that is, of course, a very important reason, because usually these small startups, they have limited financial means so funding is very important for these startups.*

As the price of development is high, the support for the government was stated as a contributing factor as to why the Netherlands was chosen for a testing site and why it is important to them.

Moreover, there are examples of active shielding by the government's efforts to create partnerships with industry that facilitate development needed for the transition. Smith and Raven (2012) define "active protective spaces as those spaces that are the result of deliberate and strategic creation by advocates of specific path-breaking innovations to shield regime selection pressures (Smith & Raven, 2012)". The Dutch government's establishment of partnerships through MIEK is a good example of the efforts of policy makers and industrial actors to come together to minimize the impact of infrastructural and financial considerations.

*We have PDI. We have MIEK.... So, there are processes where we make excesses, consortium energy plans, the PDI as a Program Infrastructure for Dutch industry. Then we have the MIEK. It's the Meerjaren infrastructure for climate. ... All those those processes are in place already.*

MIEK is an instrument for the government to manage the different demands for assistance and emission mitigation across the six industrial clusters within the Netherlands. This is an example of active shielding whereby the Netherlands attracts and protects the development of the socio-technical system by providing financial support.

### **Existing Industry & Access to Resources**

Because of the complexity in the chemical industry, the testing of these new cracking technologies requires experts within the chemical field as well as industrial processes. This type of knowledge and learning development requires the proper resources to create valuable selection experiments. An example of the necessary requirements for such development is access to different feedstocks and industrial gases like steam, Nitrogen, methane, etc. Another contributing factor of how the Netherlands goes beyond financial support for developing the technology is the need for material resources. The participant mentioned the need for different industrial resources which is available at Chemelot, for example.

*There are actually not too many locations in Europe where you can build a pilot plant. In order to build a pilot plant, you need a lot of things. One of the important things is of course all the utilities you need to have the infrastructure available. While plants, they usually need nitrogen, steam, natural gas, lots of electricity. And that is all available here on on Brightlands. Because Brightlands is located on, on Chemelot and all these utilities are actually coming from the industrial area, so from Chemelot.*

It is important to note that resources can take different forms. One significant resource the Netherlands offers is its infrastructure. Dutch infrastructure sits in the middle of the ARRA region. The chemical technology requires so much electricity, it can only be located in a place with access to large power resources.

### **Public Policies and political power**

While there are subsidy schemes in place and active participation between the industry and government to work together on a common future vision for industrial decarbonization, there are also criticisms of the system.

*Companies that are that are at the front row, yet they are facing all the insecurities from from the EU, from from the national governments, but also from raw material electricity availability. Subsidies that are changing from day-to-day. So it becomes*

Companies need a stable and predictable political and regulatory environment in order for them to be able to make sound long-term decisions about implementing their technology.

*I don't think that the carbon dioxide tax in the Netherlands is going to help. Because it it puts the industry in, in the Netherlands, in the disadvantage to. To other industry in in Western Europe.*

### **Cultural Motivation**

Lastly, one participant gave an example of an important cultural reason for success in the Netherlands: there is more room for failure.

*Yeah, by the way I think the way the employment is organized if you speak out, it's not necessarily you... you lose your job next day. So, there's a little bit of liberty in expressing yourself and that creates an environment. I think that is useful also for developing things. It creates a good climate, and also I think we gave a good social service... schooling system so you can also find the professionals to work with and to do the job actually.*

### 5.3 Nurturing

Critical to this study, the nurturing processes are identified. This is the most analytically intensive category, as it identified the learning mechanics within the niche, and how the different actors are aligned in their views of the socio-technical system.

#### 5.3.1 Expectations

The role of expectations is crucial within transition studies. Expectations and visions of the socio-technical system should be shared among actors in the network. This will allow for the right conditions for the diffusion of the technology. Here, the various expectations from participants are explored under different functional titles which were categorized.

#### **Use of Technology:**

Interestingly, when it comes to replacing fossil fuel-based furnaces, while there is no general agreement on the design of such new technology or the choice of such technology, the participants did express a preferred method as to how new technology should be implemented. As laid out in Chapter 4, there are alternative routes, such as using a turbomachine or resistive/inductive heating methods. The purpose of the new technology is to replace the fossil fuels-based furnaces in the production of light olefins.

In terms of implementing the technology, there are different aspects to consider. First, what type of electric steam cracker should be implemented? Second, should the entire fleet of crackers be replaced, or should it be done in a step-by-step process? Answers to these questions can be seen in the following excerpts, though implementation largely depends on local site conditions.

*Do you have to basically do away with everything we have and do and build something completely new? Can you build something that can be retrofitted, or do you end up with something in between? We don't know that yet. Depends also on the technology that is applied to provide the energy to the molecule, and there's about 5 different fundamental principles that can be applied. And all come with pros and cons and that is the the the search that we are obviously going through*

First, should you replace your entire fleet of crackers with an electric one? How does one go about minimizing revenue risks? How do you get reliable electricity? These are all valid questions. One interview produced an interesting solution: the option to first build a furnace next to a current one to minimize the plant's downtime due to construction.

*Well, if you if you do this correctly, yeah, you can build an electric furnace next to the existing furnace if you have the the the room to do that, there's sufficient space around the plant and that usually is the. At least then you can build a new furnace without taking any downtime*

Retrofitting a plant entails specific sequential steps, as well as the need to substitute a low emission furnace for the fossil fuel cracker.

### **Operational Considerations**

There are other concerns when implementing the socio-technical system, such as how one operates it. This leads naturally to a discussion of the environmental effects of implementing an all-electric cracker and what effects it may have on the business case.

A number of the participants identified the electricity requirement for steam crackers as being a large and important consideration: How does one handle the intermittent nature of sustainable energy? (Especially when considering a 400GW baseload) Moreover, when switching to the electric cracker, the availability of methane creates another branch of a potential business case. Should the methane be stored for intermittency? Should it be put into the gas grid? Should it be used for local power production and then electricity sold? Should it be used for steam methane reforming to produce grey hydrogen? Should it be used for power generation for the site? The answers to these questions are not straightforward and depend on a changing political, financial, and technical landscape.

*Naphtha cracker cracks naphtha into olefins, but also the naphtha cracker produces a lot of methane. And usually that methane is used to fire the ovens. So, if you replace an oven by a [company] naphtha cracker, which is electrically driven, where's the methane going to? So, these things, all these questions and that is just one of one of the questions that must be solved and there are many questions: the composition of the cracked gas be the same? There are many questions are said and. All these questions must be answered and must be there must be a positive balance in the answer before an end user decides to implement the technology. That that counts for our technology and that and exactly the same counts for all the other technology which are under development*

*15 or 16% of the, the, the naphtha that's being cracked for is cracked into methane and some hydrogen. And you use that to heat the furnaces. So that means that if you heat the furnaces with electricity, you're left with, in our case 600 kilotons of methane. That's a lot.*

There are technical questions that have yet to be addressed in order to improve the techno-economic performance. To put this into context, 600 kilotons of methane, is approximately 0.77 bcm of natural gas or 7.5 TWh. Taking an average of the TTF neutral natural gas price the past 60 days (from 21/6/2023) of 31.9 euro/MWh results in 240 million euros of additional revenue. Though this revenue depends on market conditions, one reason to decide not to inject the methane into the grid, would be to use it on-site in order to the generate the vast amount of power needed in steam cracking. Moreover, using this methane as an input into steam methane reforming could produce a large amount of grey hydrogen to be used in other industrial locations. These possibilities ought to be considered at a site level to improve the overall environmental effect of Dutch industry. However, this may be more difficult to accomplish considering the individual choice of how a cracker is run by the operators.

*But if you make a product that saves you too. And at the same time makes you money, because you sell your... your LNG and you get money for that. That money is quite substantial and certainly at the price that you get nowadays*

## Timeline

The “timing” question on implementation hangs over all decisions made in regard to new technologies. Simply put, the issue is: When is the best time to implement the new technology upgrades or is it better to build a new plant? One should also ask is the regime aligned with the niche?

These are large questions with no easy answers; because the answers depend on a series of system wide factors, as well as the personal and business agenda of individual actors. Technip Energies has one answer for retrofitting projects: their low emission furnace ready for implementation and it can be implemented in the short term, within 5 years.

## Infrastructure Requirements

The electrical demand placed on the grid is at an unprecedented scale. How to manage this implementation will be a careful juggling act by the site operator, the grid manager, as they strive to keep a balance between electrical demand, environmental conditions, and the day to day needs of transition and implementation. Maintaining the grid at a safe operating level will require further partnerships between the TSO, DSOs, and end users.

*Just to... just to supply to this to this system and that infrastructure is, at the moment, simply not there. And say if I have 600 MW of power that I need 24/7, I would have to install a lot of overdesign in my system... solar power and the wind power and the right combination of that to fulfill that demand so there will be quite a task for the grid manager to do.*

The flexibility, reliability, and safety of the system is important when considering these factors. First, the process is not made to be module or ramp up or down quickly. One participant mentioned that seasonality could be considered in the total electricity requirement, but overall, it is not yet flexible. With less than a second to respond to commands by the TSO, implementing an electric cracker with no buffer would expose the plant operator to risk, and not only the plant operator, but also the downstream processes which rely on the continuous production of ethylene and propylene.



*They come into problems when you shut down suddenly. Sometimes the the equipment. Yeah, cannot help handle it. Or there are liquids or yeah, products in in the process which need to be heated. So a lot of the processes are not designed. To be flexible. So if you look at at electric cracking, that's the the the first part of the process. But there is also a lot of downstream processes behind it. And and those are now designed for continuous processing the the, the, the, the, the product to a final product. So you have to look at the whole process if you want to make it a flexible. Process not only to the the electric cracking itself, but also to the downstream process. And what's also important is that a lot of of processes in the. In, in the chemical industry are connected, so if you make the the the Naphtha cracking flexible and the the the product. The product will be propylene and ethylene and things like that. These products will be directly used by other plants on the side. So, they have to be flexible also or you need storage.*

### 5.3.2 Actor Networks

The role of the actor network is important in the development of a niche. Intricate relationships need to be balanced with the demands of the niche from the very start of the process, while at the same time keeping a developmental eye on the needs for the future use of the technology.

The participants' discussion of actors and agents was less conclusive than anticipated. Since this socio-technical system requires very specific knowledge and is protected by actors in order to preserve their competitive edge, people are not likely to be informed on what is happening with other actors. Though there is much corporate focus on sharing and collaboration of research, in reality, there appeared to be less awareness of other actor's intentions than originally expected, given the amount of development, or at least from what the participants responded. Hence, this suggests an asymmetry in knowledge, or, taken from the other side, there is no evidence supporting strong symmetry on the specific issues of who is involved in the decision-making process and at what stage they are brought into it; However, this is not inherently disadvantageous to development. The socio-technical system is large and involves many actors. Reasons to keep all actors up to date on each other's work and progress are not strong or always legal. That said, there must be some degree of collaboration between actors and agents to increase uptake. A prime example is the relationship between the site operator, grid manager, and the technology developer. These vital three rolls must have a certain level of communication in order to ensure that infrastructure needs are planned for and actually met in a timely fashion.

*So do you think that all the actors who should be involved are involved to make this happen? P1: Yeah, yeah, absolutely.*

*I: Are there discussions right now with the grid managers and maybe the government or who are the discussions with to try to make this happen?*

*P: I don't see it... I don't... We're not involved... [redacted] spoke with... [redacted] asked the question during the meeting to the people of [chemical company]: "are you involved with the grid managers to arrange for this."*

*P: They said they were... they were involved*

## 5.4 Empowerment

In this subsection, key themes of empowerment will be presented that were found within the data. First, the main challenges facing the niche are identified as given by participants. Then, these are considered by reviewing what participants offered in terms of system requirements and temporary protections. Specific themes emerged throughout the analyzing process which are detailed below.

The operationalized form of empowerment in this study is the perspective of fit and conform vs stretch and transform. This distinction is brought out by the answers of the participants. Such data is then considered and a recommendation for further strategies for actors is given.

### 5.4.1 Main Challenges

From the interviews, there were 33 instances in which 'main challenges' were coded. Across the different codes, several themes emerged on the role of policy and its accountability; specifically: a looming threat of international competition, technical challenges, such as implementation and operation, and system requirements such as the difficulty in meeting future demand.

#### **Domestic and Global Market challenges**

Another challenge to which participants alluded, is the difficulty in maintaining a competitive industry within the Netherlands and even within the EU as a whole. The participants perceived a competitive threat from regions that are not required to switch to less emitting processes or required to adhere to stricter European policy requirements. There are competing themes here, but they can be summed up in basic market

fundamentals: supply vs demand. The future of European supply is set to rely partially on using valorized recycled plastic.

*“There is still a very good reason to think that in 2050, we will need steam cracking. And so, perhaps not in the amount of the volumes that it is today, because today we have 30 steam crackers or so in Europe. So that's that's producing much more than the than the homebound use of plastics. That may change of course, but nevertheless for the lucky survivors, there will be a good future.”*

This could represent a reason for a strategic pause by the chemical companies in implementing this technology within the NL and within the EU. There are more suitable markets and potentially future markets that will have a higher profitability compared to the Netherlands. Moreover, though the future seems to be growth oriented, the current market is experiencing contractions as demonstrated in Chapter 4.

*It's not that the companies don't wanna go greener. It is they want to survive in this transition because the shop needs to be open constantly and like you see, you've seen last year with the excessive gas price development in Europe. Companies have basically closed down plants. Some will be restarted, but some will basically not be started at all again*

### **Complexity**

Another recurring theme is the complexity of aligning all actors into a cohesive timeline in order to implement the technology. Especially within the Netherlands, there are significant expansions to the grid expected. There will be a new hydrogen backbone that will allow for hydrogen to be transported between chemical sites. There is also a push towards a circular use of plastics reducing plastics destined for landfilling or incineration.

*It's really complex system where the integration between power supply and all the power supply issues and all the ethylene plant operating issues, they have to come together.*

These new developments all have different strengths and weakness and implications on the operational concerns of a chemical site in terms of logistics but more importantly in terms of financial effects. Though there are more factors than referenced here, but the point is to illustrate how there are more concerns for the regime than only implementing the technology: not only must it be optimized for its own use, but for the operation and

success of the future system. Such a complex system requires a (quasi)-stable environment in which to make sound decisions.

### **Stable Policy Landscape**

One significant takeaway from the interviews was the impression that there is a distinct lack of certainty in the policy environment in which companies must operate. On one hand, there is a call for more direction, in the favor of chemical companies, while at the same time, there is an inherently high level of financial risk due to the changing subsidy landscape.

From the perspective of the Netherlands, the significance of the policy environment varied among actors as to what each participant chose to highlight. For example, the quote below calls for more direction in terms of material transition.

*The Commission is very powerful, and they can state very clearly, we have to work on this and this is more or less the way we have to go. Dear, dear Council, dear Parliament, you can adapt to your liking. But this is the road we're going. And that's what we're missing in the Netherlands.*

Complications appear at the EU level too. There are intergovernmental restrictions to enforce a level playing field across EU countries. One participant mentioned this as a counter example of how the Netherlands still wouldn't be able to favor the chemical industry.

*The same time, the rules and regulations from both the EU and the and the national government are not clear. There are plans and there are policies, but they change from now. /.../ From now, from now. And that and that sometimes they're also not concrete enough for companies to make decisions now. So, in that area of insecurity, it's very difficult for companies to decide what to do.*

#### 5.4.2 Fit and Conform

As explained in Chapter 2, “fit and conform” is when the niche tries to enter the regime by adapting to the institutional logic and expectations from the regime. Recommendation strategies are often difficult to implement considering the intricacies of the real world (Raven and Smith, 2012).

Fit and conform can also be considered when shielding is considered as temporary. In the interviews, policy suggestions by participants were for contract for difference which would

allow for the implementation of the niche system while the techno-economic factors or overall costs are decreasing.

Overall, there are more incidences of fit and conform than stretch and transform. The active shielding areas are framed as being temporary with specific end points and objectives agreed on. For example, the IMPROOF project aimed to reduce the process emissions by 25%. This was given as a task and is in line with Table 4, where the specific criterion of empowerment is given.

Because the niche already has a deep and broad network, it is recommended to continue nurturing the technology to increase its TRL. This will allow it to progress along the traditional method of technological development that the pathway of regimes is accustomed to. This can be achieved through further activities facilitated by both local and global actors to create a stronger sharing environment on the expectations of technologies and how best to work with electricity system operators as a guideline, given the current constraints of grids. This allows for the niche’s marketability and short-term implementation to be considered.

**Table 7: Empowerment Strategies:** Recommendations for ‘Fit and Conform’ or ‘Stretch and Transform’, the strategies column is based on Raven and Smith (2012) and Levidow et al. (2014) as the recommendations informed by the studies.

Strategies	Fit & Conform	Stretch & Transform
Local-global agency, empowerment of protective spaces	Local agents can facilitate additional ‘outward-orientated’ activities to emphasize the similarities between the niche and the conventional approach.	Agents advocate for the relearning of operations and instruction of workers to understand how to safely operate the e-crackers at a site level.
Discursive process to enable institutional reforms	Agents demonstrate the viability of the niche to policy makers and aim to standardize the process of electric cracking.	Stakeholder action-networks advocate for measures to ensure a comprehensive approach for counting carbon emissions considering the reduced emissions.
Narrative: Stories linking the present with a desirable future	The narrative that the diffusion of the niche allows for current consumption to remain while decreasing emissions.	The niche is compatible with a broader sustainable future where fossil fuel is not the dominant source of a carbon stream and enables a circular economy.

### 5.4.3 Stretch and Transform

Stretch and transform is a method to advocate for systemic regime changes rather than adapting from within the niche itself. Thus, with recommended strategies, the niche ought to advocate for itself by stretching and transforming the regime's logic, culture, and more. As seen in Table 7, the local-global niche agency could promote, for example, the standardization of knowledge needed for the socio-technical niche to be expanded. With an innovation, there must be a new manual on how to operate this machinery and the workers must be trained. This results in learning required at the local niche level to contribute to a relevant global niche retention.

One of the participants mentioned how there is lobby occurring both with the Dutch government but also within the large multi-national company itself, advocating for the continuance of the resources and attention to continuing the local niche development. In the latter case, this goes against market principles, and does not advocate for a change from the government but from a decision-making process within the company.

Moreover, a specific example of stretch and transform is the new relationship between a future oriented grid operator and the site operator. There may not be a concise and specific manner articulated given currently but with continued nurturing and learning, a new institutional dynamic between operators can be established which not only promotes this niche but also optimizes other sustainable innovations.

In Table 7, the niche actors have focused on how to expand the technical boundaries of the innovation to ensure it can play a role in a future chemical system. This is a form of stretch and transform where other factors are influencing the regime and the niche is well suited to address these concerns.

## 6 Chapter 6: Conclusion

### 6.1 Main findings

This thesis focused on the development of the electric steam cracking niche and aimed to answer the main research question: “How has the electrified steam cracking niche developed within the Netherlands, and what are its strengths and weaknesses? And how does using SNM to approach and analyze the electrified steam cracking niche diverge from or reinforce the credibility of the method?”

Through semi-structured interviews and literature reviews, a description of how the niche developed and has been shielded, nurtured, and empowered is provided. While the main research question was answered based on the five sub-questions, the response to the main research question is summarized in this paragraph and the sub-questions addressed in the following paragraphs. Both government sponsored research as well as private research from companies like Technip Energies served to initialize the social and technological development of the niche. Collaborative efforts from actors through publicly funded projects as well as pre-existing subsidies further spurred development. Strengths of the niche are that notable chemical actors with access to large resources have joined to invest in research and develop the socio-technical system and have started advocating for its substitution. Weaknesses include the high electricity demand needed to use an electric cracker and the needed infrastructure to meet this, the site complications from implementing it like with steam generation, and the uncertain policy landscape facing actors. Using SNM to study electric cracking in this study was suitable to describe and understand the protective space around the innovation, and to identify what type of support and development was influential. Even though the niche is complex and as time goes on arguably less radical, the application of the framework reinforces its ability to yield valuable results. The framework could be improved for this application by considering a more structured approach to the changing relationship between niche and regime actors.

For the first sub-question on how the niche emerged and evolved over time, participants explained how subsidies helped contribute to active research areas like direct electrification of the technology through an eFurnace using a resistive material, or directly electrifying the pipes, or making use of turbomachinery for pyrolysis. For example, the EU Horizon funding allowed for the IMPROOF project to study methods to reduce emissions which also lead to studying directly electrifying steam crackers while involving industry actors. The former E-match project, a local niche project, was a study where different technologies were compared and assessed and provided baseline recommendations to the Dutch industry and policy makers. Actors like Coolbrook, DOW, Sabic, and Technip Energies

were very active and prominent in the niche, addressing the second sub-question. Overall, the actor network was found to be both strong and deep but still has room for improvement.

To address the third research sub question, the three processes of SNM were addressed, starting with shielding. Passive shielding has taken place by pre-existing funds for development as well as active shielding brought by organized projects. The technology's readiness level is being tested and there is adequate funding to test at demonstration scale, though there are often calls for additional external funding. For nurturing, aligning the interests of the actors is a key priority, especially to include politicians to create a stable policy environment for investment decisions to be made. Likewise, there was a call for additional subsidies to eliminate the cost difference between electrically produced ethylene and conventionally produced ethylene to minimize market share losses incurred during lower capacity due to construction and potential cost differences due to other factors. Though high CO<sub>2</sub> prices work to encourage electricity-based production, other factors like electricity prices, its availability, and new capex costs stand as complications going forward.

For empowerment, the main challenges revolve around further development of the technology itself and creating the appropriate partnership between policy and private actors to facilitate implementation. In the coming years, the substitution of steam crackers with electrification is expected to occur. The expected timeline and implementation process is not yet agreed upon; however, it is likely companies start with one cracker first and test its viability before completely converting all crackers. As the emission intensities and hopefully costs of electricity drop, the viability of using electricity as opposed to oil-based heat sources increases. For the Dutch steam cracking niche, there seems to be adequate knowledge within the industrial regime on the niche but no strong guidance on implementing it at a site level; aligning on this is the next key step. This would allow for the saving of thousands of megatons of carbon emissions, taking a step in the right direction to securing the future of Dutch chemical industry.

The fourth research sub-question was address in the empowerment analysis where fit and conform and stretch and transform strategies were provided. For the local-global agency strengthening, it was suggested to conform to the current regime and demonstrate the minimal differences between the niche and conventional approach to steam cracking for example in downstream processing, both approaches produce ethylene. Likewise, the narratives around the niche could be more greatly amplified and it could better demonstrate how the innovation provides a practical route to a more desirable future; actors are encouraged to work with policy makers to incorporate the use of the technology



into future subsidy schemes. Lastly, a suggested stretch and transform strategy is to re-educate site workers on how to operate the innovation efficiently and effectively.

Since the focus of the study was an innovation system, the use of Strategic Niche Management as an analytical approach allowed for the three developmental processes occurring within the niche to be described and considered. For the fifth sub-question on the effectiveness of SNM, the defined processes did provide a structured approach in analyzing the niche which supports the credibility and reproducibility of the results. While at the same time, understanding and justifying what type and scale of innovation system is best fit for a SNM study is less clear from literature. Employing it here was adequate, however, using a technological innovation system analysis (TIS) would also have been possible and perhaps lead to more conclusive results surrounding market dynamics and entrepreneurial activities.

As with qualitative research, the study could be biased by the collection methods. The small sample size of participants makes it difficult to ensure generalizability of the data, considering that the niche is influenced by international factors. Likewise, the coding procedure differs between researchers. It is recommended for further research to continue the line of thinking on industrial transition from a subsystem process. Further research could be conducted on stakeholder involvement in implementing the site changes needed to run the electric steam cracker.

## 6.2 Recommendations

This section discusses first how to best use this thesis and secondly the most important takeaways and recommendations for actors within the Netherlands.

### 6.2.1 Optimal Use of Thesis Results

The results of this thesis focused on providing a strategic niche management study on the niche of electric steam cracking. The results can be used to inform actors within the niche as well as external actors who may be influenced by second order effects of the integration or lack thereof. Importantly, the results can be used as roadmap for challenges facing the niche and where the niche has had success, especially recommendations of the empowerment strategies surrounding narrative generation and advocating for further worker learning.

Furthermore, this thesis could be used as a reference for what a strategic niche management study is like for a geographically constrained niche and niche fighting to function within a large complex industry.

## 6.2.2 Key Findings and Recommendations

This section lists five recommendations based on the results of the study.

1. **Further development is required to understand which method has the optimal techno-economic performance.** There are different technological routes available to decarbonizing steam cracking and within the electrification niche, there are two main routes available. Regime actors are investing in all solutions but may make different decisions on when and how to implement the technology system.
2. **Continued support is crucial to continue learning which helps the niche further establish how an electric cracker should be implemented and what that means for a site operator.** Policy support has aided in advancing the technological readiness of the socio-technical system. Likewise, initiatives at Chemelot with Brightsite have increased the learning activities of the niche and increased network activities. Such learning activities have contributed to the development and empowerment of the innovation.
3. **The stakeholder network must demonstrate how the electric cracking can be used to reach climate goals while maintaining industry standards to underscore the importance of having access to future electricity generation.** Expectations amongst actors on the need and purpose of the technology is aligned; however, the timeline for when to integrate it is less clear with technological readiness levels and financial reasons obscuring it. There are key developments needed in the infrastructure to support the integration of the innovation.
4. **Encourage discussion between site and grid operators on how to prepare the electricity grid in time for electric cracking.** In the Netherlands, the electricity grid operators are already working with site operators. At the same time, participants expressed the need for the grid operators to prepare now for the future integration of the technology despite not having all the information the operators traditionally need to do so. Solutions could be that additional risk is born by the grid operators or sites must work to provide their own electricity generation in the interim.
5. **Actors advocate for the consideration of further subsidies like Contract for Difference.** The electric cracking niche faces tough domestic challenges like the cost of electricity and carbon emissions and an even more complex and stringent international market. The threat of a reduced chemical industry is serious as participants mentioned the lack of incentive for large foreign chemical companies to continue investment in an expensive landscape. Ethylene prices are already higher in Europe and could continue to increase given the uncertainty in electricity and oil prices, reducing the appeal of investing. Such subsidies could be used to mitigate these risks and additional costs for chemical companies, which could create a more stable investment environment for

these new generation of crackers to stay within the Netherlands and importantly within Europe.

## 7 Chapter 7: Discussion

### 7.1 Practical Implications

There is strong evidence showing that both passive and active shielding have served to develop the socio-technical system. The Dutch landscape is geared towards protecting the innovation and has proved to have done so thus far. As such, the international actors involved within the network have the resources and capacity to continue research and development in other regions, yet it has been most prominent in the Netherlands and in ARRA. This is good for the economic region but with a forward-looking perspective, one would hope that this indicates the technology will be substituted here. However, there is evidence of it being substituted first in other regions. This could be attributed to the work that still must be done to the system to integrate this. Setting up necessary infrastructure and access to green energy will allow the socio-technical innovation to improve the scope one emission of plastic production.

Considering both Figure 20 and the SNM perspective, it can be posited that the shielding provided by subsidies in the 2010s created a protective space which lay the foundation for sufficient protection from the regime selection pressures to facilitate the network's growth that is seen in the 2020 and 2021. Though, the results do support the role of subsidies and interest of certain actors like TNO in the technology. A dominant player in the development of the niche is Coolbrook, which contributed to the early innovation for this which began outside of the Netherlands in Finland. The network development illustrated in Figure 22 goes beyond just the published memorandums. It signals an intent to continue the development and target the diffusion of the technology.

Moreover, the nurturing aspect of SNM is itself a complex collection of interdependent decisions and actions that are if done correctly on average guiding the socio-technical system towards a collective agreement on the design and use of the innovation. From the results gathered in this study, the expectations are similar on why the technology is needed, that it must be implemented, though they deviate in regard to exactly how. The 'how' can deviate between sites but in general should look very similar.

Overall, the actors rely on one another to create the necessary infrastructure and market conditions to properly implement the technology. Of all the networks within the Netherlands, there's arguably the large pressure on TenneT as the transmission operator to expand the grid to allow for this path breaking innovation to be used. The expectation is on TenneT that it can actually create the conditions where the system provides financial and environmental benefits. Thus, the results from interviews strongly suggest that TenneT's responsibilities and therefore, role within the system, are to manage a timely

integration of both the demand and supply side of the green electricity. If the Dutch system is to learn from the global niche, the recently announced plans in Port Author, USA to implement the eFurnace include provisions to have a small nuclear reactor to power it; however, this is in a different country and site level circumstances which could prevent it from being implemented here within this local niche. All in all, the largest “weakness” or better put, the largest concern for the niche seems to be the access to reliable electricity.

Another concern within the niche is its techno-economic performance. It is now reaching demonstration level testing where actual hydrocarbon testing can occur. This shows that the nurturing is still continuing and ideally should reduce risk, allowing for better known variables on its technical performances. These developments are expected to come in late 2023 and into 2024.

There are too many unknowns to motivate a proper FID into this technology. The political climate is not sturdy; the prices of gas, electricity and CO<sub>2</sub> emissions are not stable; and lastly, the technology has not been proven using hydrocarbons. This means that there is still progressed to be had in terms of TRL and this progress is expected to come this year, at least at Ludwigshafen site and at Geleen, and to another extent at Port Author, USA.

The empowerment strategies advisable to actors within the system overall is to continue to stretch and transform the regime towards the use and implementation of this technology. In terms of infrastructure, this would mean exploring and testing energy storage technologies that are implementable on the scale required by a minimally run cracker (including downstream processing). The technology utilized depends heavily on the time response required, the capacity, and power demands, besides the business case, could be like a series of fly wheels, compressed air storage, or flexibly run hydrogen storage as suggested by participants. Moreover, this means working directly with the grid managers to balance the operational effects of a large-scale system like this.

Moreover, the safety concern of operating the innovation is an important factor. The technology developers like Technip Energies, Siemens energy, Coolbrook, ABB, Linde and more need to ensure there is adequate training for workers at the demonstration sites and sites where it will be implemented ultimately. Understanding what to do in emergency scenarios due to severe weather or power outages is important to avoid catastrophic events and to avoid burning all feedstock and releasing it to the air. Competition and market concerns were identified in the results and suggest the need for fit and conforming to the regime and even stretching and transforming it. The products from this socio-technical system must be comparable on a global scale so that regime actors are willing to implement it. This means reducing costs as often as possible and utilizing subsidies.

Moreover, the S&T requires pushing all actors into using this socio-technical innovation, in attempt to make the market equitable. However, this is unlikely and could only be realizable through government action which could also have unintended consequences.

### **Decarbonization vs Electrification**

In conducting the interviews, there were discussions on what is expected of the socio-technical system and to why this transition is happening. An important and related topic is how to decarbonize the process of producing ethylene in line with landscape pressures. First, if electrification is not only integral but realizable, what does that leave - the feedstock used within the e-crackers.

Valorizing plastic waste streams into a useable feedstock for the e-crackers is an important development which requires an additional broader and deeper network than that of electric cracking. This is so, because not only do technology developments need to be realized, but the participation of consumers and producers in the system is changing. For the proper development of e-cracking, as recommended by the stretch and transform strategies, the innovation should not create a lock-in that allows for electrification but is incompatible with the future uses as the system feedstock demands. By electrifying the system, a large step towards decarbonization is achieved; however, the system must be prepared to incorporate further technologies and responsibilities to achieve deep decarbonization.

An alternative to electrification is burning hydrogen. This is an alternative socio-technical development and was argued to reduce emission only partially, depending on the hydrogen production method, and is less energy efficient. The pull between reducing emissions as soon as possible or reducing emission permanently for the long term hangs heavily on certain companies compared to others. There are many factors going into this decision that are not publicly available and therefore, actions may not always follow logically. This contends with the natural inertia of the large regime players who would prefer to maintain their current profit structure for as long as possible. In that regard, the Dutch political action has worked one on one with clusters to facilitate this type of planning.

### **7.2 Theoretical Implications**

Throughout the study, the socio-technical innovation system also kept developing. The local niches in the Netherlands and ARRA continued interacting with the global niche: for example, as developments in China and the US were announced since the research and thinking process was conducted here in the Netherlands. Perhaps, the fact that the actors are globally well-situated, the learning process is less dependent on geography and is able

to select the best location to maximize the shielding process. Since the chemical industry faces significant pressure on its process pollution, the substitution of technology may emerge in a political landscape where there is less economic pressure.

The fact that the actors within the niche are regime actors is very interesting. Moreover, the incumbent actors ended up partnering with Coolbrook, a new entrant. Because Sabic ventures now owns part of Coolbrook, it has shown that the once path breaking technology has through both fit and conform and stretch and transform strategies, has managed to break through into a global niche, and demonstrated the ability to properly establish the extent of which it now composes the regime (and contributes to the pathway of regime) must be further explored in another study, potentially using the multi-level perspective.

The question of whether this socio-technical system is still a niche is difficult to approach, but there are strong arguments to be made in favor of it being already adapted into the regime by having high degrees of alignment and institutional logic supporting it, but it also is still a niche in that it still needs protective space and subsidies. The framework did allow the electrified steam cracking niche to be studied and understood. It permitted the protective space analysis to occur which was the original intention. It could be improved if more detailed results are the goal and that is explained further below. However, it was an effective tool to understand the niche, whereby addressing sub-question 5.

This process of conducting an SNM on a subject like electric steam cracking is a first as far as the literature search revealed. Typically, SNM works well within grassroot subjects like mentioned before with elect or over long-term transition of a large system. To do an exhaustive SNM on a subject like this, it would be necessary to conduct interviews and even hold workshops without breaching confidentiality and anti-competition laws due to the few dominant actors in Europe. While navigating confidentiality restrictions would be difficult, performing a study of a socio-technical system within this industry is enlightening on how and when smaller innovative companies, like Coolbrook, become backed and eventually owned by incumbent actors. Additionally, it is also challenging because of the specific knowledge needed to enter and rise to a level of an advisor. These two complications lend Strategic Niche Management to be a tool well suited for grass root-based studies as an advisor where the level of access is lower and there is a linked interest in non-corporations and money. Thus, in the case of this study, there could be additional benefits from using a TIS analysis. For example, the functional unit for Advocacy Coalition in TIS could permit a more fine-grained analysis on the type of advocacy the niche receives concerning Lobbying and competition lobbyists of other technologies. Moreover, the entrepreneurial activities of the niche could be detailed.

### 7.3 Limitations

This study was influenced by limitations due to the qualitative nature and the subject material as well as the inherent biases of the researcher. First, in selecting participants, there could be a bias in those willing to be interviewed since they are already open to discuss electrification and what that means for the chemical industry. This is explained as already being influenced by sustainability goals. This could be affecting data in that there could be a strong bias towards its integration and the minimizing of the weaknesses of the niche. Moreover, the chemical industry and the development of this socio-technical system is global, maintains intricate relationships, and is based on complex processes. This results in a large network of actors that may not speak with each other, and even more so, actively try not to in order to protect their commercial interests. The sample size of 10 interviews could mean that there is a bias towards the Netherlands role (though one was based in Belgium) and not accurately represent the international effects of the global niche on the local niche. Additionally, how partners within the system work together and what they worked on was difficult to ascertain because of non-disclosure agreements of the actors. Lastly, the quotes and data bits were chosen that best represent the data gathered; however, this could look different depending on the researcher.

### 7.4 Further research

This research could be extended to include speaking more in depth with all chemical sites within the ARRA region as well as holding workshops to gather more data and provide additional guidance to the actors within the system. This type of research would be recommended to gather larger and more detailed data about learning processes, interactions, and the effects of policy across the region. This could be done by conducting more sessions but also establishing a stronger rapport with the actors. This data would be valuable in a multi-level perspective analysis on the chemical industry. This could build on the theories within strategic niche management by detailing the relationship between the regime and the niche and attempting to identify niche hybridization strategies for industrial players who will likely begin relying more heavily on other partners for key resources like recycling streams and carbon capture storage and utilization.



## Bibliography

- Allen, M.R., O.P. Dube, W. Solecki, F. Aragón-Durand, W. Cramer, S. Humphreys, M. Kainuma, J. Kala, N. Mahowald, Y. Mulugetta, R. Perez, M. Wairiu, and K. Zickfeld, (2018). Framing and Context. In: Global Warming of 1.5°C. An IPCC Special Report on the impacts of global warming of 1.5°C above pre-industrial levels and related global greenhouse gas emission pathways, in the context of strengthening the global response to the threat of climate change, sustainable development, and efforts to eradicate poverty [Masson-Delmotte, V., P. Zhai, H.-O. Pörtner, D. Roberts, J. Skea, P.R. Shukla, A. Pirani, W. Moufouma-Okia, C. Péan, R. Pidcock, S. Connors, J.B.R. Matthews, Y. Chen, X. Zhou, M.I. Gomis, E. Lonnoy, T. Maycock, M. Tignor, and T. Waterfield (eds.)]. Cambridge University Press, Cambridge, UK and New York, NY, USA, pp. 49-92. <https://doi.org/10.1017/9781009157940.003>.
- Amghizar, I., Vandewalle, L. A., van Geem, K. M., & Marin, G. B. (2017). New Trends in Olefin Production. *Engineering*, 3(2), 171–178. <https://doi.org/10.1016/J.ENG.2017.02.006>
- Bauer, F., & Fuenfschilling, L. (2019). Local initiatives and global regimes – Multi-scalar transition dynamics in the chemical industry. *Journal of Cleaner Production*, 216, 172–183. <https://doi.org/10.1016/j.jclepro.2019.01.140>
- Bhaskaran, K. A., & Roth, P. (2002). The shock tube as wave reactor for kinetic studies and material systems. *Annu Rev Phys Chem*, 269. [www.elsevier.com/locate/peccs](http://www.elsevier.com/locate/peccs)
- van Boekel, T., & Oud, P. (2021). AIChE Spring Meeting and Global Congress on Process Safety. In *2021 Aiche Spring Meeting & 17th Global Congress on process safety 18-23 April 2021, online: Conference proceedings*. New York, NY, USA; American Institute of Chemical Engineers.
- Bos, H. L., Slingerland, M. A., Elbersen, W., & Rabbinge, R. (2008). Beyond agrification: Twenty five years of policy and innovation for non-food application of renewable resources in the Netherlands. In *Biofuels, Bioproducts and Biorefining* (Vol. 2, Issue 4, pp. 343–357). <https://doi.org/10.1002/bbb.84>
- Brightsite. (2020). Brightsite Steam Study. Retrieved from <https://brightsitecenter.com/wp-content/uploads/2020/11/2020-11-09-Brightsite-Steam-study.pdf>
- Brook, D. (2001). The ongoing tragedy of the commons. In *The Social Science Journal* (Vol. 38, Issue 4, pp. 611–616). Informa UK Limited. [https://doi.org/10.1016/s0362-3319\(01\)00158-6](https://doi.org/10.1016/s0362-3319(01)00158-6)

- Bruno, M. (2022). Cycling and transitions theories: A conceptual framework to assess the relationship between cycling innovations and sustainability goals. *Transportation Research Interdisciplinary Perspectives*, 15. <https://doi.org/10.1016/j.trip.2022.100642>
- Carrozzo Magli, A., Della Posta, P., & Manfredi, P. (2021). The Tragedy of the Commons as a Prisoner's Dilemma. Its Relevance for Sustainability Games. In *Sustainability* (Vol. 13, Issue 15, p. 8125). MDPI AG. <https://doi.org/10.3390/su13158125>
- Cefic, (2022, December 20). *Developing The Cracker of the Future*. <https://cefic.org/a-solution-provider-for-sustainability/chemistrycan/going-climate-neutral/developing-the-cracker-of-the-future/>
- Cefic. (2023, February 27). 2023 Facts And Figures Of The European Chemical Industry. <https://cefic.org/a-pillar-of-the-european-economy/facts-and-figures-of-the-european-chemical-industry/>
- Chemelottafel Klimaatakkoord (2022). Cluster Energie Strategie 2022 Chemelot 2030-2050. Chemelot. <https://www.chemelot.nl/IManager/MediaLink/915/77559/32791/2271493/>
- Coenen, L., Raven, R., & Verbong, G. (2010). Local niche experimentation in energy transitions: A theoretical and empirical exploration of proximity advantages and disadvantages. *Technology in Society*, 32(4), 295–302. <https://doi.org/10.1016/j.techsoc.2010.10.006>
- Coolbrook (N.D.) Piloting a Clean New Industrial Era <https://coolbrook.com/the-pilot/>. Accessed 09 January 2023.
- Elzen, B., Geels, F. W., Leeuwis, C., & van Mierlo, B. (2011). Normative contestation in transitions 'in the making': Animal welfare concerns and system innovation in pig husbandry. In *Research Policy* (Vol. 40, Issue 2, pp. 263–275). Elsevier BV. <https://doi.org/10.1016/j.respol.2010.09.018>
- Fussey, D. E., Gosling, A. J., & Lampard, D. (1978). A shock-tube study of induction times in the formation of carbon particles by pyrolysis of the C2 hydrocarbons. *Combustion and Flame*, 32(C), 181–192. [https://doi.org/10.1016/0010-2180\(78\)90092-5](https://doi.org/10.1016/0010-2180(78)90092-5)
- Ganieva, G.R., Timerkaev, B.A. Plasma-induced decomposition of heavy hydrocarbons. *Pet. Chem.* 56, 869–872 (2016). <https://doi.org/10.1134/S0965544116090048>
- Van Goethem, M.W.M. Next Generation Steam Cracking Reactor Concept. Ph.D. Thesis, Technical University of Delft, Delft, The Netherlands, 2010.

- Geels, F. W. (2002). Technological transitions as Evolutionary Reconfiguration Processes: A multilevel perspective and a case-study. *Research Policy*, 31(8-9), 1257–1274. [https://doi.org/10.1016/s0048-7333\(02\)00062-8](https://doi.org/10.1016/s0048-7333(02)00062-8)
- Geels, F. W. (2011). The multi-level perspective on sustainability transitions: Responses to seven criticisms. *Environmental Innovation and Societal Transitions*, 1(1), 24–40. <https://doi.org/10.1016/j.eist.2011.02.00>
- Gerres, T., Chaves Ávila, J. P., Llamas, P. L., & San Román, T. G. (2019). A review of cross-sector decarbonization potentials in the European energy intensive industry. In *Journal of Cleaner Production* (Vol. 210, pp. 585–601). Elsevier BV. <https://doi.org/10.1016/j.jclepro.2018.11.036>
- Gholami, Z., Gholami, F., Tišler, Z., & Vakili, M. (2021). A review on the production of light olefins using steam cracking of hydrocarbons. *Energies*, 14(23), 1–24. <https://doi.org/10.3390/en14238190>
- Hertzberg, A., Mattick, A., and Russel, D., (1993). *Apparatus for initiating pyrolysis using a shock wave*. (U.S. Patent No. 5219530A). U.S. Patent and Trademark Office. <https://worldwide.espacenet.com/patent/search?q=pn%3DUS5219530A>
- Hoogma, R., Kemp, R., Schot, J., & Truffer, B. (2002). *Experimenting for Sustainable Transport: The approach of Strategic Niche Management*. Spon Press. <https://doi.org/10.4324/9780203994061>
- IEA (2022), *ETP Clean Energy Technology Guide*, IEA, Paris <https://www.iea.org/data-and-statistics/data-tools/etp-clean-energy-technology-guide>
- Janipour, Z., de Gooyert, V., Huijbregts, M., & de Coninck, H. (2022). Industrial clustering as a barrier and an enabler for deep emission reduction: a case study of a Dutch chemical cluster. *Climate Policy*, 22(3), 320–338. <https://doi.org/10.1080/14693062.2022.2025755>
- Kao, Nawata, & Huang. (2019). Systemic Functions Evaluation based Technological Innovation System for the Sustainability of IoT in the Manufacturing Industry. In *Sustainability* (Vol. 11, Issue 8, p. 2342). MDPI AG. <https://doi.org/10.3390/su11082342>
- Kemp, R., Schot, J., & Hoogma, R. (1998). Regime shifts to sustainability through processes of niche formation: The approach of strategic niche management. *Technology Analysis and Strategic Management*, 10(2), 175–198. <https://doi.org/10.1080/09537329808524310>

- Kuhn, S. (2019). Prisoner's Dilemma. Retrieved from The Stanford Encyclopedia of Philosophy website: <https://plato.stanford.edu/archives/win2019/entries/prisoner-dilemma/>
- Kusenbergh, M., Eschenbacher, A., Djokic, M. R., Zayoud, A., Ragaert, K., De Meester, S., & Van Geem, K. M. (2022). Opportunities and challenges for the application of post-consumer plastic waste pyrolysis oils as steam cracker feedstocks: To decontaminate or not to decontaminate?. *Waste management (New York, N.Y.)*, 138, 83–115. <https://doi.org/10.1016/j.wasman.2021.11.009>
- Le Van Mao, R., Yan, H. T., Muntasar, A., & Al-Yassir, N. (2013). Blending of Non-Petroleum Compounds with Current Hydrocarbon Feeds to Use in the Thermo-Catalytic Steam-Cracking Process for the Selective Production of Light Olefins. In *New and Future Developments in Catalysis: Hybrid Materials, Composites, and Organocatalysts* (pp. 143–173). Elsevier B.V. <https://doi.org/10.1016/B978-0-444-53876-5.00007-6>
- Levidow, L., Pimbert, M., & Vanloqueren, G. (2014). Agroecological Research: Conforming—or Transforming the Dominant Agro-Food Regime? In *Agroecology and Sustainable Food Systems* (Vol. 38, Issue 10, pp. 1127–1155). Informa UK Limited. <https://doi.org/10.1080/21683565.2014.951459>
- Lloyd], [William Foster. (1980). W. F. Lloyd on the Checks to Population. In *Population and Development Review* (Vol. 6, Issue 3, p. 473). JSTOR. <https://doi.org/10.2307/1972412>
- Markard, J., & Truffer, B. (2008). Technological innovation systems and the multi-level perspective: Towards an integrated framework. In *Research Policy* (Vol. 37, Issue 4, pp. 596–615). Elsevier BV. <https://doi.org/10.1016/j.respol.2008.01.004>
- Mortensen, P., Højlund Nielsen, P. E., Aasberg-Petersen, K., & østberg, M. (2017, November 2). Induction heated reactor. (Patent No. WO2017186437A1). Europe: European Patent Office. <https://worldwide.espacenet.com/patent/search?q=pn%3DWO2017186437A1>
- Negri, A., & Ligthart, T. (2021). Decarbonisation options for the Dutch polyolefins industry. *PBL Netherlands Environmental Assessment Agency* <https://www.pbl.nl/en/publications/decarbonisation-options-for-the-dutch-polyolefins-industry>,(accessed: May 2022).
- Oliveira, C. & van Dril, A.W.N. (2021), Decarbonisation options for large volume organic chemicals production, SABIC Geleen. PBL Netherlands Environmental Assessment Agency and TNO EnergieTransitie, The Hague.

- Ortiz-Bravo, C. A., Chagas, C. A., & Toniolo, F. S. (2021). Oxidative coupling of methane (OCM): An overview of the challenges and opportunities for developing new technologies. In *Journal of Natural Gas Science and Engineering* (Vol. 96). Elsevier B.V. <https://doi.org/10.1016/j.jngse.2021.104254>
- Port of Antwerp. (2023) "Pipelines | Port of Antwerp-Bruges," *De Hele Haven in Een Klik | Port of Antwerp-Bruges*, <https://www.portofantwerpbruges.com/en/business/transport/pipelines>. Accessed 10 July. 2023
- Port of Moerdijk. (2021, September 15). Cluster Energie Strategie 2021. <https://www.portofmoerdijk.nl/media/2252/ces-rotterdam-moerdijk-final-15092021.pdf>
- Port of Moerdijk. (2022). Cluster Energie Strategie 2022. <https://www.portofmoerdijk.nl/media/2375/cluster-energie-strategie-rotterdam-moerdijk-2022.pdf>
- Posch, W. (2011). 3 Polyolefins 3.1 Industrial Processes for Polyolefin Production. *Applied Plastics Engineering Handbook*, 23–48. <https://doi.org/https://doi.org/10.1016/B978-1-4377-3514-7.10003-0>
- Raven, R. (2007). Niche accumulation and hybridisation strategies in transition processes towards a sustainable energy system: An assessment of differences and pitfalls. In *Energy Policy* (Vol. 35, Issue 4, pp. 2390–2400). Elsevier BV. <https://doi.org/10.1016/j.enpol.2006.09.003>
- Raven, R. P. J. M., & Geels, F. W. (2010). Socio-cognitive evolution in niche development: Comparative analysis of biogas development in Denmark and the Netherlands (1973-2004). *Technovation*, 30(2), 87–99. <https://doi.org/10.1016/j.technovation.2009.08.006>
- Raven, R., Kern, F., Verhees, B., & Smith, A. (2016). Niche construction and empowerment through socio-political work. A meta-analysis of six low-carbon technology cases. *Environmental Innovation and Societal Transitions*, 18, 164–180. <https://doi.org/10.1016/j.eist.2015.02.002>
- Raseev, S. (2003). Thermal and Catalytic Processes in Petroleum Refining. In *Thermal and Catalytic Processes in Petroleum Refining*. CRC Press. <https://doi.org/10.1201/9780203912300.ax1>

- Ren, T., Patel, M., & Blok, K. (2006). Olefins from conventional and heavy feedstocks: Energy use in steam cracking and alternative processes. *Energy*, 31(4), 425–451. <https://doi.org/10.1016/j.energy.2005.04.001>
- Rossetti, I., Tripodi, A., & Ramis, G. (2020). Hydrogen, ethylene and power production from bioethanol: Ready for the renewable market? *International Journal of Hydrogen Energy*, 45(17), 10292–10303. <https://doi.org/10.1016/j.ijhydene.2019.07.201>
- Rossi, F., Rovaglio, M., & Manenti, F. (2019). Model predictive control and dynamic real-time optimization of steam cracking units. In *Computer Aided Chemical Engineering* (pp. 873–897). Elsevier. <https://doi.org/10.1016/b978-0-444-64087-1.00018-8>
- Rotmans, J., & Loorbach, D. (2009). Complexity and transition management. *Journal of Industrial Ecology*, 13(2), 184–196. <https://doi.org/10.1111/j.1530-9290.2009.00116.x>
- RVO. (n.d.). Subsidy mission-driven research, development and innovation (MOOI). [business.gov.nl. https://business.gov.nl/subsidy/subsidy-mission-driven-research-development-and-innovation-mooi/](https://business.gov.nl/subsidy/subsidy-mission-driven-research-development-and-innovation-mooi/)
- RVO. (2019, July 19). *Demonstratie Energie- en Klimaatinnovatie (DEI+)*. [rvo.gov.nl. https://www.rvo.nl/subsidies-financiering/dei](https://www.rvo.nl/subsidies-financiering/dei)
- Rubini, D., Karefyllidis, N., Xu, L., Rosic, B., & Johannesdahl, H. (2022). A new robust regenerative turbo-reactor concept for clean hydrocarbon cracking. *Journal of the Global Power and Propulsion Society*, 6, 135–150. <https://doi.org/10.33737/jgpps/150550>
- Rubini, D., Rosnic, B. and Coolbrook Oy. (2021). The Technological Revolution Towards A Novel Turbomachine: Clean and Sustainable Hydrocarbon Cracking. <https://projectsites.eng.ox.ac.uk/media/1357/dylan-rubini-poster.pdf> [Poster presentation]
- Sabic (2022, September 1). BASF, SABIC and Linde start construction of the world's first large scale electrically heated steam cracker furnaces. <https://www.sabic.com/en/news/36814-basf-sabic-and-linde-start-construction-of-the-worlds-first-large-scale-electrically-heated-steam-cracker-furnaces>
- Schiffer, Z. J., & Manthiram, K. (2017). Electrification and Decarbonization of the Chemical Industry. In *Joule* (Vol. 1, Issue 1, pp. 10–14). Elsevier BV. <https://doi.org/10.1016/j.joule.2017.07.008>

- Schot, J., & Geels, F. W. (2008). Strategic niche management and sustainable innovation journeys: theory, findings, research agenda, and policy. *Technology Analysis and Strategic Management*, 537–554. <https://doi.org/10.1080/09537320802292651>
- Statista (2022, March 22), Ethylene Demand Capacity Forecast World Wide. <https://www.statista.com/statistics/1246694/ethylene-demand-capacity-forecast-worldwide/>
- Stevenson, S. A., HUCKMAN, M., & JIAN, H. (2023, February 16). Furnace including electrically powered heating elements arranged for uniform heating and related methods. (Patent No. WO2023016968A1). Europe: European Patent Office. <https://worldwide.espacenet.com/patent/search?q=pn%3DWO2023016968A1>
- Seppala, J., Hiltunen, J., & Purola, B.-M. (2016). Process and rotary machine type reactor. Patent NO. US2014243569A1) United States: U.S Patent and Trademark Office. <https://worldwide.espacenet.com/patent/search?q=pn%3DUS2014243569A1>
- Smith, A., & Raven, R. (2012). What is protective space? Reconsidering niches in transitions to sustainability. *Research Policy*, 41(6), 1025–1036. <https://doi.org/10.1016/j.respol.2011.12.012>
- Son, H., Kim, M., & Kim, J. K. (2022). Sustainable process integration of electrification technologies with industrial energy systems. *Energy*, 239. <https://doi.org/10.1016/j.energy.2021.122060>
- van Summeren, Luc F.M. and Wieczorek, Anna J. and Verbong, Geert and Bombaerts, Gunter J.T., Blending in, to Transform the Regime from within: Niche Hybridisation Strategies of Irish Energy Communities. Available at SSRN: <https://ssrn.com/abstract=4203646> or <http://dx.doi.org/10.2139/ssrn.4203646>
- Susur, E., Hidalgo, A., & Chiaroni, D. (2019). The emergence of regional industrial ecosystem niches: A conceptual framework and a case study. In *Journal of Cleaner Production* (Vol. 208, pp. 1642–1657). Elsevier BV. <https://doi.org/10.1016/j.jclepro.2018.10.163>
- Technip Energies. (2021). *Ethylene: A world leader in the design and construction of ethylene facilities*. <https://www.technipenergies.com/sites/energies/files/2021-03/Ethylene.pdf>
- Technip Energies. (2023 June 1). *Technip Energies, LyondellBasell and Chevron Phillips Chemical Sign MOU for Electric Cracking Ethylene Furnace*. [Press release].

<https://www.technipenergies.com/en/media/news/technip-energies-lyondellbasell-and-chevron-phillips-chemical-sign-mou-electric-cracking>

- Teske, S. *et al.* (2022). *Scopes 1, 2, and 3 Industry Emissions and Future Pathways*. In: Teske, S. (eds) *Achieving the Paris Climate Agreement Goals*. Springer, Cham. [https://doi.org/10.1007/978-3-030-99177-7\\_13](https://doi.org/10.1007/978-3-030-99177-7_13)
- Tijani, M. E. H., Zondag, H., & Van Delft, Y. (2022). Review of Electric Cracking of Hydrocarbons. In *ACS Sustainable Chemistry & Engineering* (Vol. 10, Issue 49, pp. 16070–16089). American Chemical Society (ACS). <https://doi.org/10.1021/acssuschemeng.2c03427>
- Tijani, M. E. H., Zondag, H., & Van Delft, Y. (2022). Review of Electric Cracking of Hydrocarbons. In *ACS Sustainable Chemistry and Engineering*. American Chemical Society. <https://doi.org/10.1021/acssuschemeng.2c03427>
- TNO (2022, October 25) E-mission MOOI: TNO steunt Dow en Shell bij elektrisch kraken. <https://www.tno.nl/nl/duurzaam/co2-neutrale-industrie/co2-uitstoot-industrie-afvangen/elektrisch-kraken/>
- Treanor, C. E., Hall, J. G., Center, C. C. A. T., Sciences, S. U. N. Y. B. F. E. A., & Research, U. S. A. F. O. S. (1982). *Shock Tubes and Waves: Proceedings of the Thirteenth International Symposium on Shock Tubes and Waves*. State University of New York Press. <https://books.google.co.uk/books?id=lzsbBgOzPo0C>
- Verbong, G. P. J., & Geels, F. W. (2010). Exploring sustainability transitions in the electricity sector with socio-technical pathways. In *Technological Forecasting and Social Change* (Vol. 77, Issue 8, pp. 1214–1221). Elsevier BV. <https://doi.org/10.1016/j.techfore.2010.04.008>
- Verhees, B., Raven, R., Veraart, F., Smith, A., & Kern, F. (2013). The development of solar PV in The Netherlands: A case of survival in unfriendly contexts. In *Renewable and Sustainable Energy Reviews* (Vol. 19, pp. 275–289). Elsevier BV. <https://doi.org/10.1016/j.rser.2012.11.011>
- Walrave, B., Talmar, M., Podoyntsyna, K. S., Romme, A. G. L., & Verbong, G. P. J. (2018). A multi-level perspective on innovation ecosystems for path-breaking innovation. In *Technological Forecasting and Social Change* (Vol. 136, pp. 103–113). Elsevier BV. <https://doi.org/10.1016/j.techfore.2017.04.011>
- Wieczorek, A. J., Raven, R., & Berkhout, F. (2015). Transnational linkages in sustainability experiments: A typology and the case of solar photovoltaic energy in India.



*Environmental Innovation and Societal Transitions*, 17, 149–165.  
<https://doi.org/10.1016/j.eist.2015.01.001>

Wu, W., Hu, H., & Ding, D. (2021). Low-temperature ethylene production for indirect electrification in chemical production. In *Cell Reports Physical Science* (Vol. 2, Issue 4). Cell Press. <https://doi.org/10.1016/j.xcrp.2021.100405>

Yuan, B., Zhang, Y., Du, W., Wang, M., & Qian, F. (2019). Assessment of energy saving potential of an industrial ethylene cracking furnace using advanced exergy analysis. *Applied Energy*, 254(July), 113583.  
<https://doi.org/10.1016/j.apenergy.2019.113583>

## Appendix

### A.1 Topic guide

---

#### **Intro:**

---

- Go through consent form again.
  - Introduction
  - ask light questions first – why is the Netherlands where the research is happening?
- 

#### **Shielding:**

---

- In your experience, what EU country has the most e-crackers/ e-cracking research?
  - How come?
  - Why do you believe it was chosen as the site of the various e-cracker research locations?
    - Do you believe there is enough support from the government in terms of policies for e-cracking to continue to develop?
  - How was it when you first became involved with e-cracking?
    - How difficult has accessing funding been in your experience?
    - Is there enough funding available to keep performing research and testing in the coming years in your opinion?
    - Who do you believe has contributed most greatly to the development of e-cracking behind the scenes?
  - Why?
- 

#### **Nurturing:**

---

- Could you list actors and agents that you think are important for developing and implementing e-crackers?
    - How many other actors/stakeholders are on the project your involved in?
    - Are there any meetings with different stake holders? And what are they like? What kind of topics are usually discussed?
  - What kind of questions are usually posed in these meetings?
    - How do you all come to an agreement for what the next steps should be?
  - Considering everyone involved in making e-cracking across Europe, have you seen examples of collaboration (e.g. conferences, consortiums etc.) where people come together and share the knowledge they've learned?
    - Are there any examples that stand out to you?
  - Do you believe there is enough collaboration between actors?
  - Are there more actors/agents you believe could join the efforts to make e-cracking more prominent?
  - Could you give examples and why?
  - What have been the largest hurdles in developing the technology? E.g. pure science behind it, engineering, etc.
- 

#### **Visioning:**

---

- What are you views in the future use of e-cracking (for light olefin production)?
  - Do stake holder groups meet routinely?
    - If so, what is a typical meeting like?
-

- 
- Do you ever discuss how you aim to use the crackers? As in how to implement them.
  - Are there technologies that must be used with e-crackers like CCS/CCU?
- 

**Empowerment:**

---

- Do you think e-cracking would solve the environmental concerns the chemical industry is facing?
    - Do you believe it's pushing the industry towards sustainability?
    - Do you believe it's keeping a non-sustainable industry alive?
  - Do you believe e-cracking is the future? How long do you expect it to take until it becomes standard practice?
- 

**Technology uses:**

---

- What are the most important factors in implementing the technology from your perspective?
  - What has been the most challenging aspect of developing the tech behind e-cracking?
  - Are there foreseeable supply chain issues, staffing issues, etc.?
  - Barriers: (if applicable)?
  - How has the Russian war and subsequent price hike for gas and electricity affected the discussions of e-crackers?
  - Are people concerned about this?
  - In your opinion, are people discussing how to meet the high-power demand enough?
  - How is that conversion going? Are there future to build more parks for example, or will it rely mostly on another source? Or has it not been discussed at all?
  - Is this being discussed?
  - How do you expect feedstocks to look in European steam crackers in the near future and in the next 10-15 years?
  - Let's talk more about the larger picture and the push for circular economy, is it feasible for e-crackers to have a majority of biobased fuels like bio-naphtha or bio-pyrolysis?
    - Are the feedstock discussion produces effect mitigation strategies?
  - How they see the interaction between fossil free chemical feedstocks and current feedstock... thoughts on 2050 ff free?
  - How they see their tech related to ETS carbon scheme/net zero goals? And in practice / how many steam crackers in NL/EU
- 

**End:**

---

- Is there anything else you'd like to add to the topic?
  - How do you feel the interview went?
  - Remind them of end procedure
  - Thank you for your time.
-

## A.2 Codebook

**Table 8: Codebook for Data Analysis.** This table contains information on the code used to analyze the collected data.

Category Label	Code	Strategy used	Description	Example from Data
Shielding	Pre-existing support	Deductive	Evidence of geographic protection like subsidy, research grants, industry	“There are processes where we make excesses, consortium energy plans the PDI as a Program Infrastructure for Dutch industry. Then we have the MIEK. It's the Meerjaren infrastructure for climate. So, there you have to look up the abbreviations, but. All those those processes are in place already”
	Subsidy	Deductive	Mentioning of subsidy schemes and criticism of subsidy	“I think that the stimulation of innovation is a national thing, but also European thing, because of European programs and also for demonstrators, you have innovation funds and stuff like that. So there's support mechanisms from Europe as well for major developments.”
	Tolerance of poor techno-economic performance	Deductive	Evidence of belief in low TRL and evidence of employed business case	“if you can modify and then I'm again thinking very big and going from from those big furnaces which are like 10 and 20 meters to those very compact designs of of Siemens and Coolbrook. That will cost money and if you can gradually do it by for example, taking one out at a 3me. Yeah, you are. First of all, distribu3ng a bit the risks but also the costs. It it it... Int: So, it's viable. P1: Yeah, I I think it's it's. Just a very I think the stepway is approach approach is the best approach as long as the technology is not fully

				developed, and it won't be by 2050."
	Further experimentations	Deductive	E-cracking expansion in terms of projects/ additional research	"Sabic is developing that resistive E-cracker, they are going to start it up this year."
	Knowledge exchange	Deductive	Evidence of knowledge exchange. For example, partnerships, collaborations, conventions, publications, and joint developments	"Also, Coolbrook already worked together with Cambridge and Oxford and they do still work with them"
Nurturing	Learning processes	Deductive	Evidence of learning process: 1 <sup>st</sup> and 2 <sup>nd</sup> order, doing, systemic, etc.	"That's why we, we are trying to test the new equipment, and we basically did. To convince the oil companies that indeed, there is something that has been tested, and we want to bring it to a higher technology readiness level such that there's risk they're taking is very limited."
	Shared expectations	Deductive	Evidence of shared expectation (explicitly mentioned by participant)	"Dow has some. Different perspective than than SABIC has. SABIC is going directly to electrification and doesn't want to go towards steam, reforming and then the. This yes option and now is going first to a CCS option and and later on and firing with hydrogen and later on going to electrification. So here you. See that both companies follow different development paths."

	Broad network	Deductive	Evidence (or lack of) numerous actors and agents involved	<p>“So do you think that all the actors who should be involved are involved to make this happen?”</p> <p>P1: Yeah, yeah, absolutely.”</p>
	Deep network	Deductive	Evidence (or lack of) resource-heavy actors and agents involved	<p>“Europe really provides the funds. To do the research, for example, like also the university is involved in European projects like horizon projects, also in Flanders. The university got or my professor got some money to do innovation or to do research focusing on electrification or or plastic wastes, recirculation or chemical recirculation. So yeah, there is indeed a lot of money that is flowing through industry towards research.”</p>
Articulation of socio-technical system	Feedstock use	Deductive	Mentioning of feedstock for ethylene cracking	<p>“It doesn't work like that, but yeah, and that's one of the projects the UGent is working on together with Coolbrook is modifying their reactor or or investigating the impacts of using mixed plastic waste pyrolysis oils in their reactor, be it in combination with traditional naphtha or with with ethane or something. Well, it is not only with Coolbrook, but also other players like Engie, Borealis, etc. Showing the multi-disciplinarity of this entire issue”</p>
	Technical considerations	Inductive	Influential (technical) factors in operational strategy	<p>“if you take the electric route, the direct electric route, you have no off gas anymore, so no losses. You could electrify instead, all the pumps, all the compressors, so the energy savings of electric cracking amount up to 25 or 30%</p>

---

			compared with conventional. So, with hydrogen you see the opposite you have in the energy chain huge losses. While with electricity you see that you have huge savings. Well, then the picture is clear to me.”
Environmental effects	Inductive	Expressed concerns or perspectives on environmental effects of substitution (or lack of)	“Well, you don't need to burn it anymore. But that CO2 emission reduction is not taking place at [cracker company]. It's taking place at an incinerator. Or we work on green feedstock, green naphtha. We did it already. We can do it. It's it's it's the simplest, but the CO2 emission reduction is only partly taking place at the cracker of [cracking company]. The rest, the green carbon molecules, and that's a pretty big thing. 85% of the products in the cracker is not a fuel, not a fuel that we use directly”
Cost concerns	Inductive	Financial concerns mentioned	“Now, all of a sudden and and we designed the plant to be able to do that and the capacity is fully. Now if you have to cut back on your, the use of the installation, that means that that has to be made-up for later in time. So, then you have to over build your plant from a capacity perspective to be able to absorb. The models that it is not utilized. So that is a CapEx consequence. So the installations become relatively bigger and their base load is relatively smaller. And so that is the economical question.”
Hydrogen	Inductive	Mentioning of hydrogen use	“First we take a lot of effort into producing it and then burning it. Why would it? Why would

---

---

			<p>you want to do that? But if you look at the at the total energy system and you say I wanna use yeah, wind and solar energy, then then there are moments that there is no wind, there is no. Sun and then. Then what do you do then? That case, hydrogen burning is probably a good. A good alternative.”</p>
Risk	Inductive	Factors influencing risk of implementation, development, political or financial risk	<p>“What your unique selling point as a company is that you always make sure you keep the light on. Then I don’t really know if it’s. If it helps to from. Point of view from tenant view to be more risky and. Putting in more capacity when the near future doesn't really ask for it.” – op6</p>
CCS	Inductive	Discussion of the role or use of carbon capture units, storage, and or utilization	<p>“But at this point in time, it’s it’s very difficult. But again, what what we see is indeed companies are account3ng for it. They they make sure, for example, in Ineos is building a new plant here in Antwerp and new steam cracker. They account for the potential use of hydrogen, the potential implementation of electricity, and they even lee sufficient room or sufficient space to build capture units, so they are accounting for it. Also, Technip is cooperating with Shell to build a massive steam cracker in China”</p>
Timeline	Inductive	Mentioning of timeline for development, implementation, use of the technology or the system	<p>“We’re just demonstrating, and then we need to have a business case, and we need some subsidy. Final investment decision, FID, we may take that three years from now”</p>

---



			around the socio-technical system itself	
	Policy	Inductive	Influential Dutch, EU, and global policy.	<p>“I think subsidies will help to take risk. For example, the ethylene market, ethylene and propylene market, so steam cracking again. It's a highly competitive market. If you can increase your yields of light olefins with 0.1 weight percent. We are talking about millions of EUR of additional profit, so if you would want to be your first adopter and changing your technology you take risk of losing millions or even billions of euros. So, if there can be some offset of that by for example, in these subsidies, I think 4 companies will be more willing to take risk. Which makes sense of course, because they have like, OK, we take a risk. Maybe we should be rewarded or incentivized for it, because why would we try to lose our competitive advantage by adopting a new approach, if that will cost us billions over multiple years?”</p>
Network	Actors	Deductive	Mentioning of other actor agents, either their responsibilities, roles, incentives	“GasUnie”
Empowerment	Framing temporary shielding	Deductive	Framing protection as temporary, depending on market conditions or	“Europe really provides the funds. To do the research, for example, like also the university is involved in European projects like horizon projects, also in

		assigned limited duration	Flanders. The university got or my professor got some money to do innovation or to do research focusing on electrification or or plastic wastes, recirculation or chemical recirculation. So yeah, there is indeed a lot of money that is flowing through industry towards research.”
Main challenges	Deductive	Mentioned or suggested challenges facing the socio-technical niche	“One of the the issues that we have of course is the availability of green electricity. Sustainable generated electricity that is still much too limited. So that has that has to be developed, but it is not something that is that is not something in which. Is active and. And also the at least that counts for for the Netherlands, but probably also for other countries. The electricity grid is capacity wise, completely insufficient.”
No radical change required	Deductive	Evidence that the system (regime) is already suited for the adoption of the socio-technical regime	“Oh yeah, we, we as a company are doing that. Yeah, OK. So. It has been decided. [redacted] also investing also in the electric furnace and also we are investing in the electric cracking, the rotating apparatus”
System requirements	Deductive	Elaboration on requirements of the sociotechnical system either what is lacking or what is currently given.	“Sustainable production in the later stage? Not today, but maybe after 5 to 10 years is no longer a a choice for the industry it is. It has become a sort of a must. Sort of a survival strategy because and and that that is something that I I mean”