

Based on Outseal Studio and Haiwell Cloud Scada to Check Parking System Availability using Arduino Nano on The Miniature Parking Lot

Henri Sulistiawan¹, Rini Puji Astutik², Yunani Ristanto³

^{1,2,3}Electrical Engineering, Faculty of Engineering, Muhammadiyah University Gresik
Jl. Sumatra No. 101, Mt. Malang, Randuagung, Gresik Regency 61121

Informasi Makalah

Dikirim, 27 Oktober 2023
Diterima, 17 November 2023
Diterbitkan, 14 Desember 2023

Keyword:

Arduino nano PLC
Outseal studio
SCADA
Slot
Parking area

ABSTRACT

The availability of parking areas is still difficult to monitor effectively. User often encounter messy vehicles in the parking lot. It caused the vehicle to disappear. This research needs to determine the availability of vehicles at the parking location. The field of electronics is in the form of industrial automation systems. This development began with the emergence of several controllers, including microcontrollers and microprocessors. One of the functions of this development was to make human work easier by controlling a system automatically, for example, automated parking. This system works in the area of a parking slot and records the number of vehicles in each slot parking. This system is controlled via Arduino nano PLC which then displays using SCADA, namely Haiwell Cloud SCADA. This parking system proved to connect parking slots, open automatic door latches, and provide information in the form of data reports for each slot to the parking attendant. This research was able to make user easier for parking officers, to control the parking area as well as increase the security of the parking area and minimize the loss of vehicles parked in each slot.

Korespondensi Penulis:

Henri Sulistiawan, Rini Puji Astutik, Yunani Ristanto
Undergraduate Study Program in Electrical Engineering
Faculty of Engineering, Muhammadiyah University Gresik
Jl. Sumatra No. 101, Mt. Malang, Randuagung, Gresik Regency 61121
Email : henri.sulistiawan@gmail.com; astutik_rpa@umg.ac.id

1. INTRODUCTION

In this era of rapid technological development, especially in the electrical sector, one of them is automation. Basically, this development leads to control (processing systems), one of which is PLC. The programmable Logic Controller (PLC) is the central controlling unit in the industry or a process [1]. An example of a PLC type is the Arduino nano PLC. One of the benefits of a PLC is an automatic parking system.

In general, the parking system is an element that aims to provide a place to tidy up the position of the vehicle. In public cases, what often happens is that the vehicle disappears in the parking area and makes the owner less comfortable when leaving the vehicle to carry out activities. Apart from that, parking is often messy due to a lack of real monitoring of parking slots.

Based on previous research, this controlled parking system has been discussed. From [2] with the title "Design and Construction of an Automatic System Trainer Module for Controlling Motorbike Capacity in Parking Areas Based on Outseal PLC," it can be seen that in calculating vehicles using the display of incoming and outgoing vehicles with MAX7129 LED dot matrix, not with SCADA. In the second research discussed in [3] with the title "Design and Construction of an Information System for the Availability of Parking Slots in Malls" here it can be seen that this parking system uses an Arduino Mega 2560 as a processor. In the input device, the researcher uses an infrared sensor, and an ultrasonic sensor, while the output uses a motor. servo in each parking slot and for display using a TFT LCD and using thermal printing as a print of incoming vehicle tickets. This research uses an Arduino idea without using an external PLC and is not equipped with SCADA. The third research is discussed in [4] with the title "Designing a Parking System Design Using Outseal PLC Based on Internet of Things (IoT)". This research creates a tool using Outseal PLC v3.2 and ESP8266 as a wireless communication medium. This research uses RFID and proximity cylinders. The fourth research is discussed in [5] with the title "Miniature determination of 3-story automatic parking availability based on PLC and HMI". This research creates a 3-story parking lot with a PLC and then displays it on the HMI. In [6] with

the title "Designing Automatic Vertical Rotating Car Parking System Control Using Outseal PLC and Android HMI". This research creates a rotating parking system with Mega V1 outseal which is then displayed on the Android HMI. In [7] with the title "prototype of an automatic multi-story parking system based on a programmable logic controller and SCADA-HMI". This research designs and makes a prototype of an automatic multi-story parking system using control based on a Programmable Logic Controller (PLC) and SCADA-Human Machine Interface (HMI). The programming language used is a ladder diagram created using CX-Program 9.0 software. Making a prototype of a multi-story parking lot with 16 spaces in the form of a 4 x 4 matrix column, a lift lifting mechanism with chain transmission, a drive wheel mechanism with straight gears (spurs gears), and a pneumatic tool moving mechanism using a slider. In [8] with the title "Informative parking system model based on a programmable logic controller (PLC)". This research creates an automatic parking system that can provide information on the location of empty parking slots to drivers by using a Programmable Logic Controller (PLC) and LDR sensors as portal openers. In [9] with the title "parking system design with parking location recommendations". This research designs a parking system with recommended parking locations. The motorist will receive a printout of a ticket from a thermal printer that says the recommended parking location, namely the one closest to the entrance to the building or facility, programmed via a microcontroller. In [10] with the title "parking system design with parking location recommendations". This research designs a system to open and close entry and exit portals automatically and provide information on parking slots that are still available to parking service users on a monitor screen placed before the entry portal. This design uses an infrared sensor and LED lights in each parking slot, where the infrared sensor will read obstacles that are right in front of the sensor, and the LED lights function to provide an indication that it will light up if the slot is filled and the lights will not come on if the parking slot is not filled.

From the background above, the author innovated, namely creating a Based on Outseal Studio and Haiwell Cloud Scada to Check Parking System Availability using Arduino Nano on The Miniature Parking Lot. The work process in this system is monitoring workflow in the area of a parking slot and recording the number of vehicles in each parking slot. This system is controlled via Arduino nano PLC which then displays using SCADA, namely Haiwell Cloud SCADA. This parking system is designed to monitor parking slots, open automatic door latches and provide information in the form of report data for each slot to parking officers. From the results of making this tool, this problem can be overcome.

2. METHOD

This research method is divided into three stages to implement the Parking Check Availability System. The first stage is Designing the detail part and the next stage is designing the overall system as a prototype. The third stage the last stage is the implementation

2.1. Designing Detailed Part

This design process uses Arduino Nano[11] as a PLC and the main control system is programmed using Outseal Studio software[12]. Apart from that, to monitor this system, Haiwell Cloud SCADA software is used. Haiwell Cloud SCADA is a SCADA and HMI design software developed by Xiamen Haiwell Technology Co., Ltd based on Net-framework[13]. The design is started by assembling the electronic components and programming them so that the system can work as the desired work plan. The detailed design system can be seen in Figure 1.

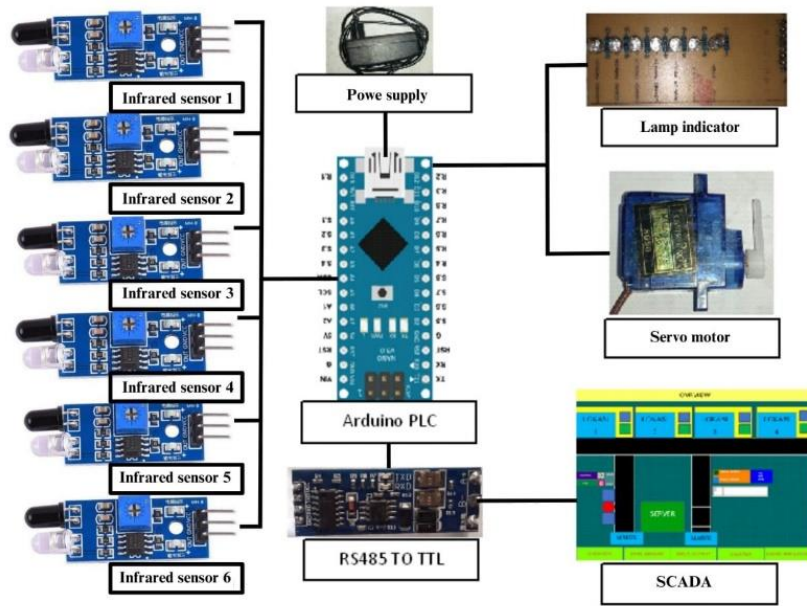

Figure 1. Designing Detailed Part

The following is the location of the system design input and output configuration in Figure 1.

Table 1. Input And Output Configuration

Input Component	Pin Arduino nano PLC	Output Component	Pin Arduino nano PLC
Infrared sensors 1	S1	Lamp Indicator slot 1	R1
Infrared sensors 2	S2	Lamp Indicator slot 2	R2
Infrared sensors 3	S3	Lamp Indicator slot 3	R3
Infrared sensors 4	S4	Lamp Indicator slot 4	R4
Infrared sensors 5	S5	Lamp Indicator slot full	R5
Infrared sensors 6	S6	Lamp Indicator start mode	R6
RS 485 to ttl	Rx,Tx	Lamp Indicator stop mode	R8
Power supply	V.in	Servo motor	R7

The interface design and its features as in SCADA(Supervisory control and data acquisition)[14] which contained input-output device, report, overview design, and counter as shown in Figure 2

2.1.1. Input Output

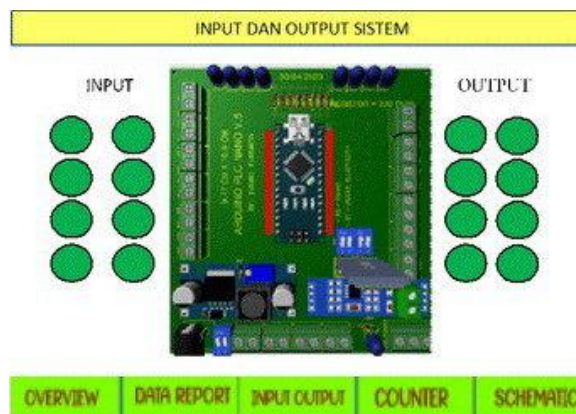

Figure 2. Scada Input-Output Display Design

In the input and output display, it indicates the input-output part used in the both external and internal system.

2.1.2. Data Report



The image shows a software interface for a data report. At the top, there is a yellow header bar with the word "REPORT" in black. Below this is a dark green background. In the center, there is a white rectangular area containing a table titled "REPORT COUNTER SLOT PARKIR". The table has five columns: "START DATE : TIME", "COUNTER 1", "COUNTER 2", "END DATE : COUNTER 3", and "COUNTER 4". The table is currently empty. Below the table, there is a navigation bar with five buttons: "OVERVIEW", "DATA REPORT", "INPUT OUTPUT", "COUNTER", and "SCHEMATIC". The "DATA REPORT" button is highlighted in green.

Figure 3. Scada Data Report Display Design

The report Display part shows system events in real-time from the start until the end of the operation system as seen on Figure 3. In this part, the report can also be saved as a document in PDF, XLS, and CSV formats. The read data contains counter data for each parking slot per day.

2.1.3. Overview

In Figure 4, the overview display is used for monitoring the condition of the parking lot as real. In this part, the server can monitor and find out the location of the parking that is being used. This display is also the main display because the program start button is located here.

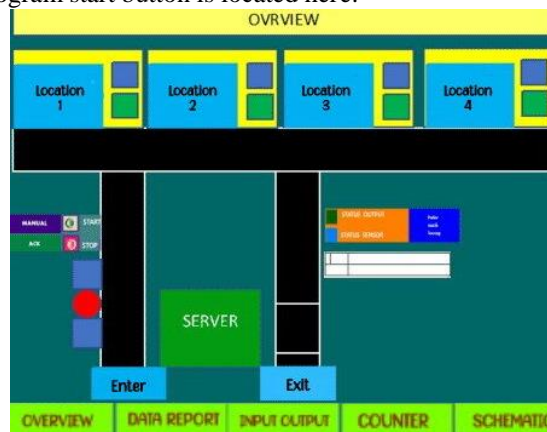

Figure 4. Scada overview display design

2.1.4. Counter

The counter display is to determine the number of vehicles parked in each slot per day as shown in Figure 5. This platform is also equipped with a reset button on each parking slot counter that functions to reset the number of counters per day.

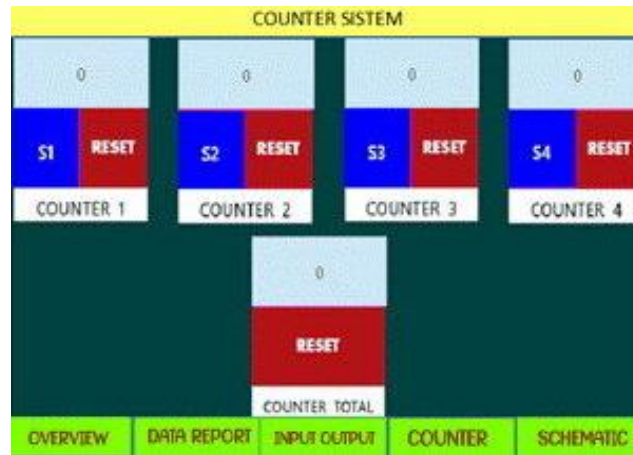

Figure 5. Scada Counter Display Design

2.2. Prototype Design

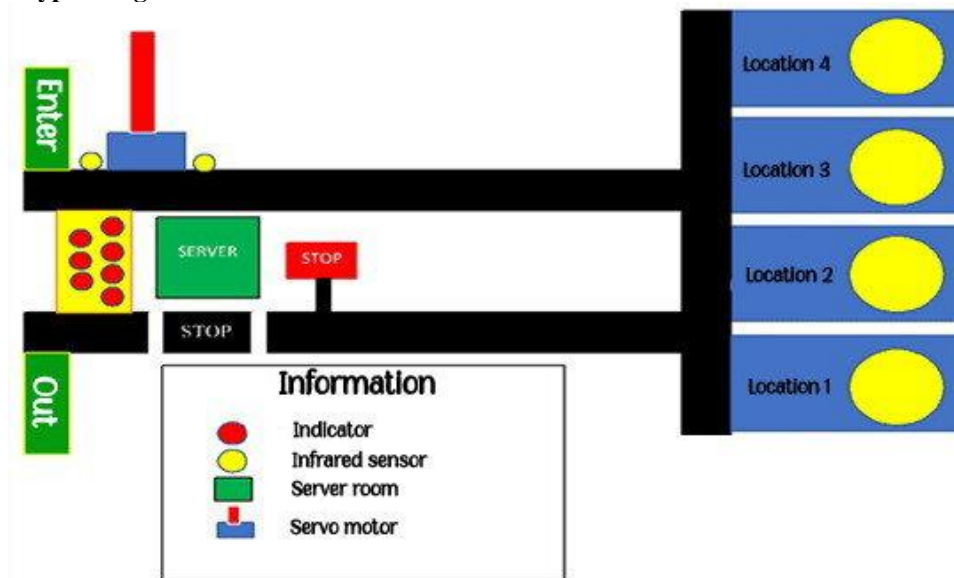

Figure 6. Prototype Design

Figure 6 displays a prototype design plan using 6 infrared sensors, where the 2 sensors are placed to automatically open and close the door bars. In the meantime, the other 4 sensors are for detecting and counting the vehicles in each slot. The SG90 servo motor is used as a controller for opening and closing the door bars. All processes will be controlled and monitored via the SCADA system with running time on a PC or laptop in real-time.

2.3. Function Diagram

The function of diagram of this system is a sequence of instructions for running the system program tool in a design. Functionally, flowcharts can provide a clear picture of the work sequence of the tool system that has been made. The purpose of making flowcharts is to show step-by-step problem-solving in a simple, structured, and clear way. An explanation of the flow of the tool system can be seen in Figure 7.

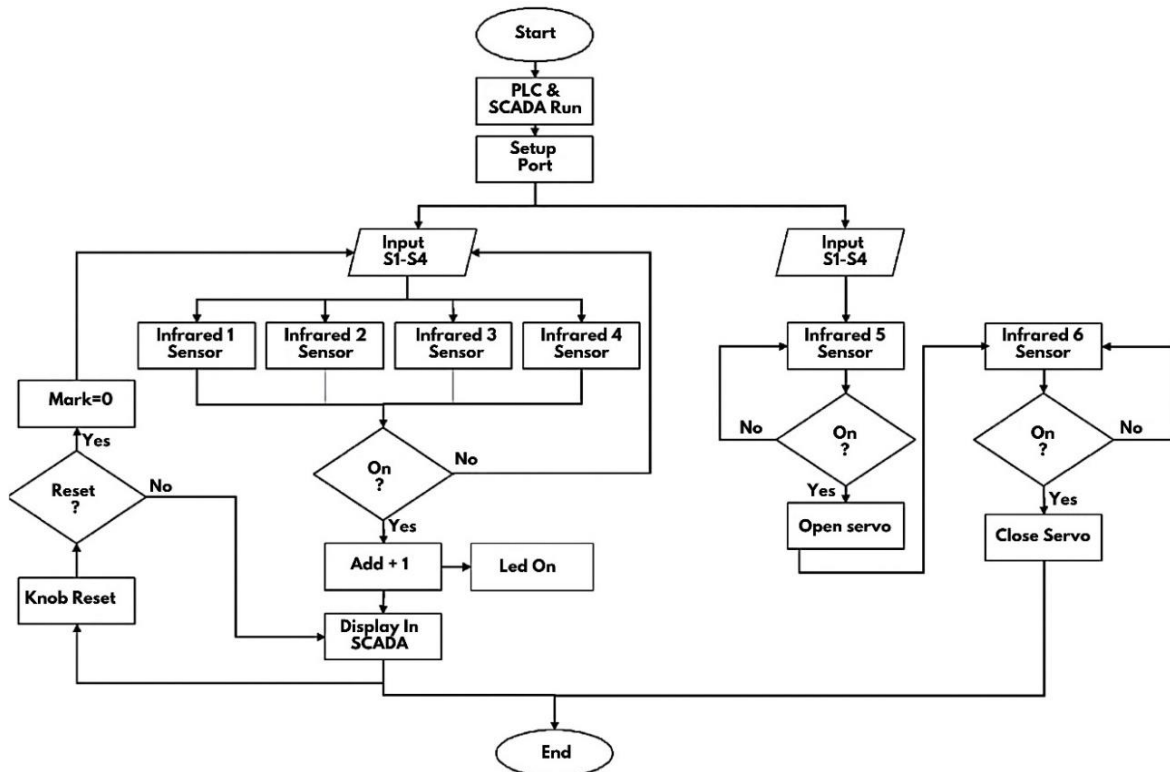

Figure 7. Function Diagram

In accordance with Figure 7, the way this system works is centered on the PLC and SCADA as centralized controllers. The diagram starts from the Arduino PLC and SCADA when on. In its working principle, the infrared sensor works by emitting light from an LED, and the light is received by a photodiode [15]. When the infrared sensor connected to pin S5 turns on, the servo motor will change position to center, meaning the door latch is open, while the infrared sensor connected to pin S6 turns on, the servo motor will change position to right, meaning the door latch will close. Then an infrared sensor connected to pins S1-S4 functions to detect every vehicle that enters the parking slot. At that time the counter value will increase automatically. In the calculations and processes, the input and output will be monitored in real-time

3. RESULTS AND DISCUSSION



Figure 8. Prototype Design Results

After completing the tool that is made, the next step is to test the tool. At the time of testing this tool, there were several analysis including doorstop testing, infrared sensor testing, counter testing, overall testing, and SCADA testing. The following are test data on the based on outseal studio and haiwell cloud SCADA to check parking system availability using Arduino Nano on the miniature parking lot. SCADA systems are generally connected to PLCs via communication protocols [16].

3.1. Doorstop Testing and Analysis

In this doorstop test, it is used to test the feasibility of the doorstop as the entrance to this system.



Figure 9. System Doorstop

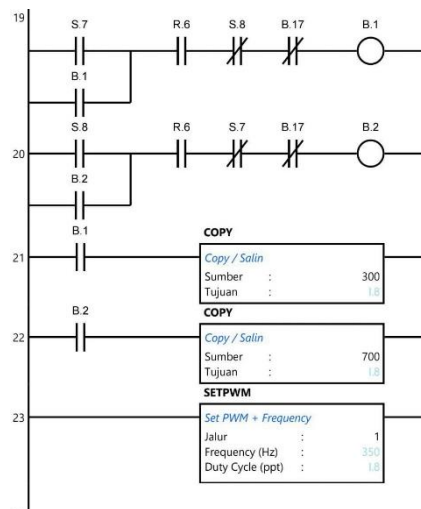

Figure 10. Doorstop ladder

Table 2. Crossbar System Test Results

No	Test type	Compatibility		Information
		Yes	No	
1.	The door latch opens	V		The door bar opens if the sensor is on
2.	The door latch closes	V		The door bar closes if the sensor is on

From the data results, the door latch opens if infrared sensor 5 is detected with a duty cycle of 300 ppt, while the door latch closes if infrared sensor 6 is detected with a duty cycle of 700 ppt. The resulting duty cycle value itself is a scale in the form of a servo motor's degree rotation, namely 0o and 90o [17].

3.2. Infrared Sensor Testing



Figure 11. System Infrared Sensors

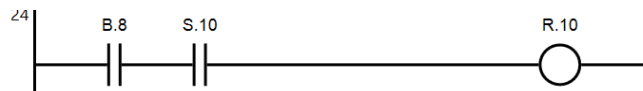

Figure 12. Infrared Sensor Ladder

The results of the infrared sensor was used in this system.

Table 3. Infrared Sensor Test Results

Sensors list	Detection testing			Information
	1 Cm	3 Cm	5 Cm	
Infrared sensors 1	V	V	V	The sensor works according to function
Infrared Sensors 2	V	V	V	The sensor works according to function
Infrared sensors 3	V	V	V	The sensor works according to function
Infrared sensors 4	V	V	V	The sensor works according to function
Infrared sensors 5	V	V	V	The sensor works according to function
Infrared sensors 6	V	V	V	The sensor works according to function

Table 3. shows all 6 infrared sensors can work properly. The sensors can also detect objects up to 5 cm with a voltage of 5 vdc.

3.3. Counter Testing and Analysis

The third test is counter-testing on the system. This test aims to determine the performance of the counter on the sensor according to function or not. This test was carried out 3 times. The following is the counter-test result data as in Table 4.

Table 4. Counter Test Results

No	Counter Test	Output				Counter total	Keterangan
		Counter 1	Counter 2	Counter 3	Counter 4		
1.	2 x	2	2	2	2	8	According To Function
2.	3 x	3	3	3	3	12	According To Function
3.	5 x	5	5	5	5	20	According To Function

From table 4 the counter can work well, namely being able to count the vehicles parked in the parking slot.

3.4. Testing and Analysis of Parking Slots



Figure 13. Testing and Analysis Of Parking Slots

The fourth test is the parking slot test. This test includes testing sensors and counters on this system. The purpose of this overall test is to follow up on previous tests related to the performance of this system and ensure synchronization between the sensor and counter. This test is for an online test between Outseal Studio and the created system. This research is related to displays of fully occupied parking slots [18].

Table 5. Parking Slot Test Results

Time and date	Slots 1		Slots 2		Slots 3		Slots 4	
	Infrared sensors 1	Counter 1	Infrared sensors 2	Counter 2	Infrared sensors 3	Counter 3	Infrared sensors 4	Counter 4
17.22 August 15, 2023	High	1	Low	0	Low	0	Low	0
17.23 August 15, 2023	Low	1	High	1	Low	0	Low	0
17.24 August 15, 2023	Low	1	Low	1	High	1	Low	0

From the results of the data in Table 5, it can be seen that if the condition of the sensor is high then the counter will be counted, on the contrary when the condition of the sensor is Low thus the counter will remain the same at previous counting.

3.5. SCADA Testing and Analysis (Overall Testing)

The last test is SCADA testing where this test is also called overall testing. This test consists of a series of all previous tests. The purpose of this test is to determine the relationship between software and hardware in this system. In this case, it will be tested evenly.

Table 6. Scada Testing(Overall Testing)

SCADA Parts	Figure	Test Result
Input Output		<p>Figure 14 shows the external input and output display. This input means the address S1-S8 while the output address is R1-R8. In this display, if the input is in High condition, the color will change to bright and vice versa.</p>

Figure 14. Input Output Display

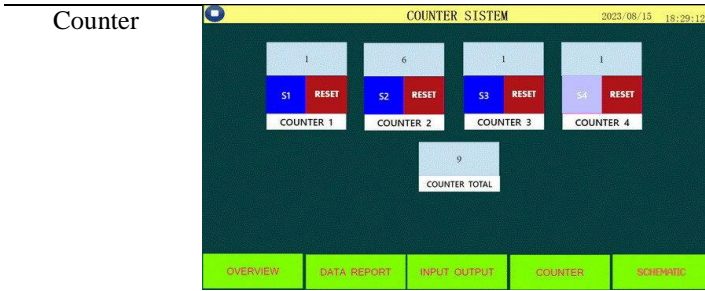

Figure 15. Counter Display

Figure 15 shows the external input and output display. This input means the address S1-S8 while the output address is R1-R8. In this display, if the input is in High condition, the color changes to light and vice versa.



Figure 16. Overview Display

Figure 16 shows a view where if the start button is pressed the Bitlamp will be green. At location 4, the Bitlamp flashes green which means there is a parked vehicle and the light blue Bitlamp indicates the sensor status is High. Meanwhile, in Locations 1 – 3 there are no changes, which means the slots are empty.

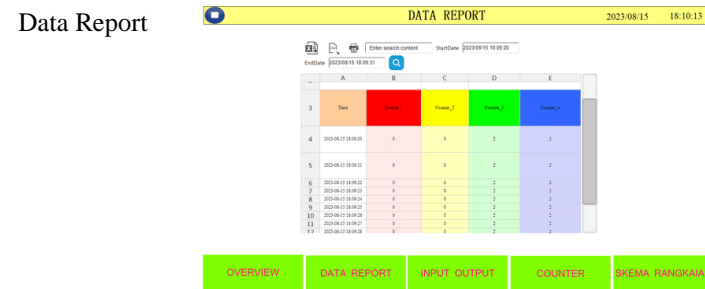

Figure 17. Display Data Reports

Figure 17 shows the data report display. In this display there is a table where this table will record parking location events in real time. The results of this report can be saved in Excel, PDF and CSV format. Figure 18 shows the results of the report data in Excel form. From this test, what is recorded is the counter sensor in parking slots 1 to 4. The time the data is recorded is every second.

Record And Report Counter Location					
Parking					
Time	Counter_1	Counter_2	Counter_3	Counter_4	
10/23/2023 12:34	5	7	1	11	
10/23/2023 12:34	5	7	1	11	
10/23/2023 12:34	5	7	1	11	
10/23/2023 12:34	5	7	1	11	
10/23/2023 12:34	5	7	1	11	
10/23/2023 12:34	5	7	1	11	
10/23/2023 12:34	5	7	1	11	
10/23/2023 12:34	5	7	1	11	
10/23/2023 12:34	5	7	1	11	
10/23/2023 12:34	5	7	1	11	
10/23/2023 12:34	5	7	1	11	
10/23/2023 12:34	5	7	1	11	
10/23/2023 12:34	5	7	1	11	
10/23/2023 12:34	5	7	1	11	
10/23/2023 12:34	5	7	1	11	
10/23/2023 12:34	5	7	1	11	
10/23/2023 12:34	5	7	1	11	
10/23/2023 12:34	5	7	1	11	
10/23/2023 12:34	5	7	1	11	
10/23/2023 12:34	5	7	1	11	
10/23/2023 12:34	5	7	1	11	

Figure 18. Data Report Results in Excel Form

From the test results above, the system we created runs according to its performance. Apart from that, this system is equipped with SCADA which can help officers monitor parking slots. SCADA is simply defined as a system that can supervise, control, and acquire data on plant [18]. This SCADA system is also equipped with data reports that can be used to monitor the use of parking slots and the number of vehicles during the time set by the parking officer. This is an update from the previous one which only focused on the hardware parking slot system, meaning that in terms of security and real-time monitoring, it was still lacking. It related to [19] slot parking provides information on empty parking slots and can search for the drivers parking slot location if the driver forgot where he parked. SCADA system uses a computer to display sensor values, display graphs, store data in a database and display it on a web system [20].

4. CONCLUSION

Based on the results of research on designing a Based on Outseal Studio and Haiwell Cloud Scada to Check Parking System Availability using Arduino Nano on The Miniature Parking Lot were the door latch uses a servo motor and infrared sensor to run normally, the reading of the infrared sensor as a counter for each parking slot was 100% accurate and there were no problems during the 3x tests, SCADA and hardware are very compatible so that when used, it works well. this system based on SCADA can make it easier for parking officers to control and improve security in the parking area. The other advantages of this system make user easy to monitor slots and the number of vehicles.

REFERENCE

- [1] M. G. Hudedmani, R. M. Umayal, S. K. Kabberalli, And R. Hittalamani, "Programmable Logic Controller (Plc) In Automation," *Adv. J. Grad. Res.*, Vol. 2, No. 1, Pp. 37–45, 2017, Doi: 10.21467/Ajgr.2.1.37-45.
- [2] U. M. Area, "Motor Di Area Parkir Berbasis Skripsi Oleh : Imei Iriansyach Perangin-Angin Fakultas Teknik Universitas Medan Area Medan Skripsi Diajukan Sebagai Salah Satu Syarat Untuk Memperoleh Gelar Sarjana Di Fakultas Teknik Universitas Medan Area Oleh : Imei Irians," 2023, [Online]. Available: <https://Repositori.Uma.Ac.Id/Handle/123456789/19662>
- [3] A. P. Wiseso, D. Irawan, And R. P. Astutik, "Rancang Bangun Sistem Informasi Ketersediaan Slot Parkir Dalam Mall," *E-Link J. Tek. Elektro Dan Inform.*, Vol. 17, No. 2, P. 19, 2022, Doi: 10.30587/E-Link.V17i2.4640.
- [4] R. S. Violinda And P. Jaya, "Rancang Bangun Sistem Parkir Menggunakan Plc Outseal Berbasis Internet Of Things (Iot)," *Voteteknika (Vocational Tek. Elektron. Dan Inform.*, Vol. 10, No. 3, P. 48, 2022, Doi: 10.24036/Voteteknika.V10i3.118849.
- [5] D. Monika, "Miniature Penentuan Kesediaan Parkir Otomatis 3 Lantai Berbasis Plc Dan Hmi," *Electrices*, Vol. 3, No. 1, Pp. 21–27, 2021, Doi: 10.32722/Ees.V3i1.3919.
- [6] R. Purnomo *Et Al.*, "Id : 23 Pengendalian Sistem Parkir Mobil Putar Vertikal Otomatis Menggunakan Plc Outseal Dan Hmi Android The Controlling Automatic Vertical Rotating Car Parking System Using A Plc Outseal And Android Hmi," No. November 2021, Pp. 182–190, 2021.
- [7] S. Tresno *Et Al.*, "Prototipe Sistem Parkir Bertingkat Otomatis Berbasis Programmable Logic Controller Dan Scada-Hmi," Vol. 8, No. Kommit, Pp. 381–390, 2014.
- [8] S. R. Intan A, D. Triyanto, And Ilhamsyah, "Model Sistem Parkir Informatif Berbasis Programmable Logic Controller (Plc)," *J. Coding Sist. Komput. Univ. Tanjungpura*, Vol. 02, No. 1, Pp. 1–9, 2014.
- [9] D. Zulkarnain, E. S. Julian, J. T. Elektro, F. T. Industri, And U. Trisakti, "1611-3200-1-Sm," Vol. 14, Pp. 17–28, 2017.
- [10] A. I. Pulungan, S. Sumarno, I. Gunawan, H. S. Tambunan, And A. R. Damanik, "Rancang Bangun Sistem Parkir Dan Ketersediaan Slot Parkir Otomatis Menggunakan Arduino," *J. Ilmu Komput. Dan Inform.*, Vol. 2, No. 2, Pp. 127–136, 2022, Doi: 10.54082/Jiki.33.
- [11] C. Nagib, "Universitas 17 Agustus 1945 Surabaya," *Univ. 17 Agustus 1945 Surabaya*, Pp. 6–34, 2014, [Online]. Available: <https://Repo.Undiksha.Ac.Id/1980/9/1705031010-Lampiran.Pdf>
- [12] A. Bakhtiar, "Panduan Dasar Outseal Plc," *Agung Bakhtiar*, Pp. 1–183, 2019.
- [13] Pt. Canindo Daya ElektriKA, "Haiwell Cloud Scada," 2023. www.Canindo-Cde.Co.Id (Accessed Aug. 05, 2023).
- [14] J. Gao *Et Al.*, "Scada Communication And Security Issues," *Secur. Commun. Networks*, Vol. 7, No. 1, Pp. 175–194, 2014, Doi: 10.1002/Sec.698.
- [15] Fabiana Meijon Fadul, "Penjelasan Sensor Infra Red," Pp. 5–30, 2019.
- [16] Kermani M, Behin A, Erfan S, Catalina A, Domenico L, Luigi M. 2021. Intelligent Energy Management Based on SCADA system in a real Microgrid for Smart Building Applications. *Renewable Energy*. Vol 171, Pp 1115-1127. <https://doi.org/10.1016/j.renene.2021.03.008>.
- [17] A Paula S, "Microcontroller Motor Servo," *J. Chem. Inf. Model.*, Vol. 53, No. 9, Pp. 1689–1699, 2013.
- [18] Lindarwati, Salamah I, Asriyadi, Fadli M. 2019. Sistem Persediaan Slot Parkir dengan Pengaman Data Berbasis Arduino. *Jurnal Digit*. Vol 9, No 2, Pp 122-131. ISSN 2088-589X.
- [19] M Kusnadi, Zaenal Abidin, and Arief Budi Laksono, "Rancang Bangun Alat Sistem Pendeteksi Jumlah Ketersediaan Slot Parkir Mobil Dalam Gedung," *J. JEETech*, vol. 1, no. 1, pp. 31–36, 2020, doi: 10.48056/jeetech.v1i1.9.
- [20] C. Henriques, I. G. A. P. R. Agung, and L. Jasa, "Rancang Bangun Sensor Jarak sebagai Alat Bantu Memarkir Mobil berbasis Mikrokontroler Arduino Uno," *Maj. Ilm. Teknol. Elektro*, Vol.17, No.1, Pp. 72, 2018, doi: 10.24843/mitte.2018.v17i01.p10.

