



**Associated conference:** 5th International Small Sample Test Techniques Conference

**Conference location:** Swansea University, Bay Campus

**Conference date:** 10th - 12 July 2018

---

**How to cite:** Omacht, D., Kubanek, Z., Dolezal, R., Kubon, Z. & Cizek, P. 2018. Temperature measurement and calibration in small punch creep testing machines and equipment. *Ubiquity Proceedings*, 1(S1): 37 DOI: <https://doi.org/10.5334/uproc.37>

**Published on:** 10 September 2018

---

**Copyright:** © 2018 The Author(s). This is an open-access article distributed under the terms of the Creative Commons Attribution 4.0 International License (CC-BY 4.0), which permits unrestricted use, distribution, and reproduction in any medium, provided the original author and source are credited. See <http://creativecommons.org/licenses/by/4.0/>.

**UBIQUITY PROCEEDINGS**



<https://ubiquityproceedings.com>

# Temperature measurement and calibration in small punch creep testing machines and equipment

D. Omacht <sup>1,\*</sup>, Z.Kubanek <sup>2</sup>, R.Dolezal <sup>3</sup>, Z.Kubon <sup>4</sup>, P.Cizek <sup>5</sup>

<sup>1</sup> daniel.omacht@mmvyzkum.cz

<sup>2</sup> zdenek.kubanek@mmvyzkum.cz

<sup>3</sup> roman.dolezal@mmvyzkum.cz

<sup>4</sup> zdenek.kubon@mmvyzkum.cz

<sup>5</sup> petr.cizek@mmvyzkum.cz

\* Material and Metallurgical Research Ltd., Pohranicni 693/31, Ostrava, 70300, Czech Republic  
[daniel.omacht@mmvyzkum.cz](mailto:daniel.omacht@mmvyzkum.cz), Tel.: +42-060-861-5303

**Abstract:** Serious lifetime estimation of machinery working in the power industry is conditioned by knowledge of an actual state of used construction materials. Determination of degradation degree by detection of mechanical properties of materials at machine parts used in operating conditions without the necessity of stopping operation of the apparatus and machine component disintegration in the past has led to the development of miniaturized test specimens associated with the emergence of special test procedures and methods. One of these methods is the small punch test (SPT) performed at room, low or elevated temperatures. Just testing temperature is one of the most important test parameters. The accuracy of measurement of this variable is a basic condition of repeatability, compatibility and comparability of the measured testing results. Very small specimen size, the way how it is stored in the heating system, the prescribed tolerance of measurement accuracy determines the way of measuring and controlling its temperature. One possible way of measuring specimen temperature is using a thermocouple directly touching its surface in the test process. However, this method is influenced by the unequal heat conduction between the specimen and the punch with the push pin in an upper direction and the cartridge sitting in the rod within the lower direction. How to determine the real specimen temperature in control systems of SPUTT500 testing machine is the subject of this paper.

**Keywords:** lifetime; temperature; calibration; thermocouple; small punch creep testing

---

## 1. Introduction

The constantly increasing need to determine the degree of degradation of machine parts operating under operating conditions without the necessity of machine shutdown and disintegration of the machine components led to the establishment of the ECISS / TC 101 technical committee at the end of 2016. The Commission was created within the French Standards Association AFNOR, a member of the International Standards Organization (ISO). ECISS / TC 101 consists of 40 members from 15 different European countries. Its purpose and the main objective were to elaborate and present a completely new proposal of the European Testing Standard (TC 101WI) dealing with the estimation of tensile, fracture and creep characteristics of materials from the results of Small Punch Testing. The Name of this proposal is 'Metallic materials-Small punch test method ' [2] and replaces the existing 'CEN Workshop Agreement' of 2007 (CWA 15627/2007) [1]. The proposal was submitted 12.12.2017. In 2018, the draft will be assessed and voted by representatives of each national standardization body. If the proposal is adopted, the new standard will be published by the end of 2019.

Small punch testing method is very simple at first glance. However, by upon closer examination we encounter a lot of issues arising from its use. In order to be able to compare the measured results in different laboratories and different devices, the prescribed test conditions must be strictly respected.

## 2. Specimen temperature measurement

One of the most important test parameters by small punch creep testing is undoubtedly the temperature. The method of its measurement, accuracy and tolerances are given in the draft standard [2]. How to ensure that these requirements are met under real test conditions? It should be noted that the test specimen is very small and that its properties in the test cannot be influenced in any way, for example by welding the specific end of the thermocouple onto its surface. The situation is also complicated by the fact that the sample is stored in a protective atmosphere of

argon and that SPT is a long-term continuous testing. Therefore, it is necessary to choose a method of measuring specimen temperature in the closest position and with the possibility of regular verification.

After many years of development and testing at the SPUTT500 (Fig.1), continuous specimen temperature measurement has been performed by a thermocouple that touches the lower surface of the sample and simultaneously transfers its deflection (Fig.2). The specially designed thermocouple (pos.5 -T3) is firmly integrated into the measuring system of the test machine. The basic question was whether the temperature measured by it is really the actual specimen temperature and how to verify it. In order to answer this, many tests were carried out. We had to modify the design of the cartridge, the argon chamber and machine control software too.



**Figure 1.** SPUTT 500 - Small punch creep testing machine.

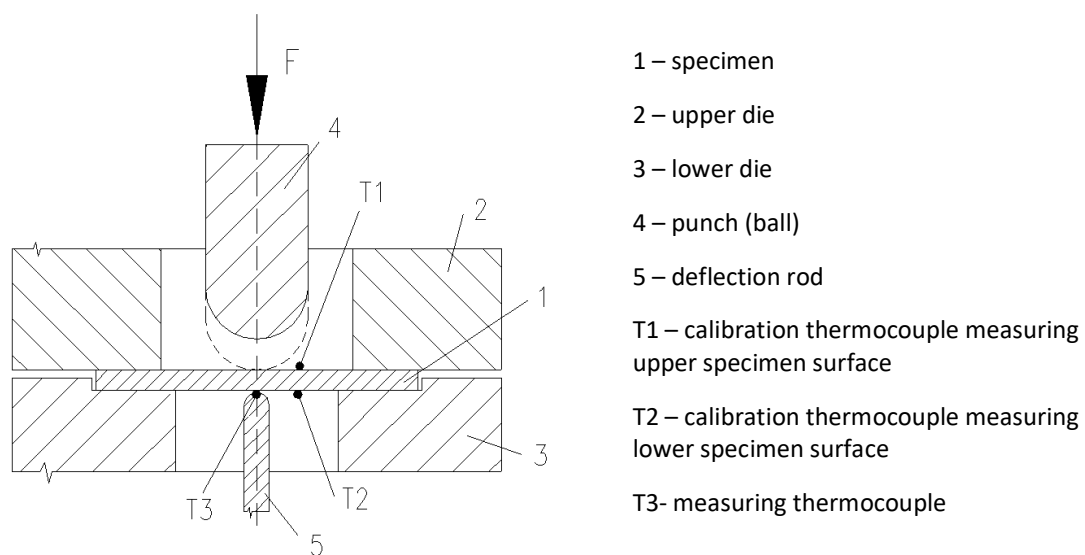

**Figure 2.** Comparative measurement scheme.

### 2.1. Comparative method

Performed tests were focused on the comparison of the temperature measured between the installed measuring thermocouple (T3) and the calibration thermocouple T1, T2 (Fig. 2).

### 2.2. Measuring thermocouple

The measuring thermocouple is a thermocouple type S (T3), which is the most suitable for performance long-term creep tests with highest accuracy and stability. The basic test prerequisite was the knowledge of the accuracy measurement of the used sensor. Therefore, it was removed from the machine system together with the data acquisition module and verified in an accredited metrological measuring center. The calibration protocol (Fig. 3, 4, 5) shows the observed deviations from the set nominal temperature.



Nominal Temperature [°C]	Thermocouple T1 [°C]	Deviation [°C]
404,8	404,7	-0,1
554,8	555,2	0,4
704,0	704,4	0,4
804,4	805,4	1,0

Figures 3, 4 and 5. Calibration certificate of the thermocouple.

### 2.3. 'Calibration' thermocouple

The actual temperature of the test sample was measured using a so-called 'calibration' thermocouple. It was carefully made and consists of two K-type thermocouples that were welded to the lower and upper surfaces of the specimen (Fig.6,7,8).

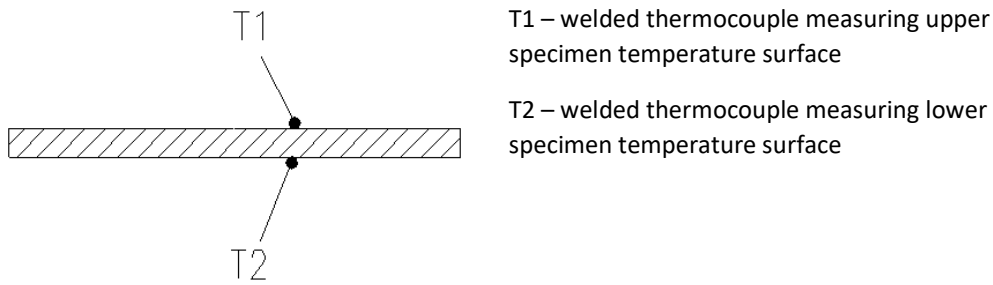
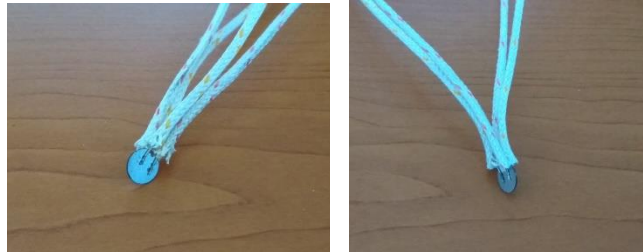

Figure 6. ‘Calibration’ thermocouple.



Figures 7 and 8. Location of measuring points in the ‘calibration’ thermocouple.

The ‘calibration’ thermocouple was subsequently verified in an accredited metrological measuring center with a data acquisition module (Fig. 9, Table 1, 2). As both sensors were made from the same footage, their variation from the set nominal temperature is almost identical (Table 1,2). The internal testing system of the machine has been modified so that thermocouple can be inserted into the test cartridge and the protective tube anytime (Fig. 10).

VITKOVICE TESTING CENTER s.r.o.			
Kontrolní metrologické středisko Ruská 268/1101, 268 00 OSTRAVA - VITKOVICE			
	Kalibrační laborator č. 2381 akreditovaná Českým institutem pro akreditaci s.p.a. dle ČSN EN ISO 9001:2015/2018		
Tel: 485 1 41 2 38 90 1000 Tel: 485 1 41 2 38 90 1004 Tel: 485 1 41 2 38 90 10 00 Tel: 485 1 41 2 38 90 10 00	KMS - Pracoviště 2 VITKOVICE TESTING CENTER s.r.o. Ruská, město 268 268 00 OSTRAVA - VITKOVICE	Tel: 485 1 41 2 38 90 10 00 Tel: 485 1 41 2 38 90 10 00	Strana: 1 z 2

**KALIBRAČNÍ LIST**  
č.: 0166/06/18

Datum vyřízení: 22.12.18  
 Schválil: Ing. Jiří Radoš  
 Podpis: *J. Radoš*

Ověřovatelka: MĀTERÁLOVÁ A METALURGICKÁ VÝZKUMNÁ ústřední ústav  
 Puhovská 48/21, Ostrava-Vitkovice 780 02  
 Město: Ostrava-Vitkovice  
 Specifická podmínka: Termodynamický tlak - 0 -  
 (Výsledky v °C)  
 (Výsledky v °C)  
 Výsledky: 25  
 Počet kusů: 2  
 Datum příjmu: 22.12.18  
 Počet průběhů: 2  
 Datum kalibrace: 22.12.18  
 Kalibrant: Václav Čížek  
 Právo: *Čížek*

**1.4. Měřící podmínky a kalibrační údaje:**

Měřící látka	Průběh	Průměr kalibrace	Maximální
Termodynamický tlak - 0	01/18	22.12.18	VITKOVICE L.M.L. č. 2381 a 2382 (KMS 1 06)
Termodynamický tlak - 0	02/18	22.12.18	VITKOVICE L.M.L. č. 2381 a 2382 (KMS 1 06)

**1.5. Podmínky kalibrace:**  
 Kalibrace byla provedena při teplotě (25 ± 0,2) °C  
 Podmínky kalibrace: 22.12.18

Uplatnění kalibrace: Kalibrace byla provedena v souladu s normou ČSN EN ISO 9001:2015/2018. Kalibrace byla provedena v souladu s normou ČSN EN ISO 9001:2015/2018. Kalibrace byla provedena v souladu s normou ČSN EN ISO 9001:2015/2018. Kalibrace byla provedena v souladu s normou ČSN EN ISO 9001:2015/2018.

Figure 9. Calibration certificate of ‘calibration’ thermocouple.

**Tables 1 and 2.** Deviations of thermocouples T1, T2.

Nominal Temperature [°C]	Thermocouple T1 [°C]	Deviation [°C]
600,1	598,4	-1,7
650,4	648,6	-1,8
699,4	697,8	-1,6

Nominal Temperature [°C]	Thermocouple T2 [°C]	Deviation [°C]
600,1	598,3	-1,8
650,4	648,7	-1,7
699,4	697,8	-1,6



**Figure 10.** Mounting 'calibration' thermocouple into the machine.

#### 2.4 Comparative testing

In accordance with the draft of the TC101WI test standard, the SP creep test can be performed either without preload or with little preload. For a higher repeatability of the measured results is required perfect heating of whole system before starting loading process. The condition is considered to be perfect warming where the dimension of the individual parts due to the influence of heating and thermal expansion remains stable or unchanging. It is possible to observe it at the deflection sensor, the value of which varies with changing specimen and inner system parts temperature.

Due to the asymmetric heat transfer in the cartridge where the test sample is stored, there is a certain redistribution of heat in the system after full load application. This may cause a rapid sample temperature change and also affects the measured specimen deflection.

For more uniform heating of the whole system and the higher repeatability of the measured results, it is advantageous to use a small preload - the pushing mandrel then contacts the upper surface of the punch which is in contact with the tested specimen. The whole system (specimen, cartridge, punch, lower and upper mandrel) is perfectly warm before full load application and this will not change even after application of the load.

To determine the actual specimen temperature, were performed five tests on the SPUTT 500 test machine with 12N preload. A calibration program (Fig. 11,12,13,14) was created with the possibility of setting five temperature levels in the range (400 ÷ 800) °C. The soaking time has been set to 90 minutes, which is sufficient time for a perfect and even heating of the whole system.

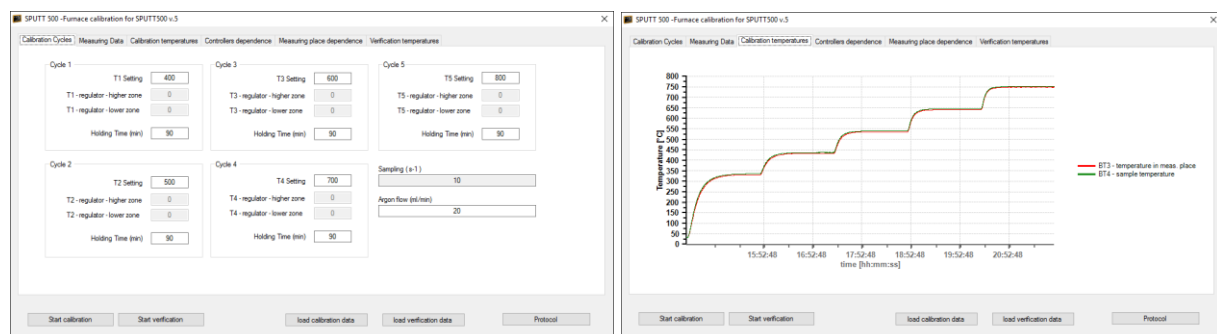



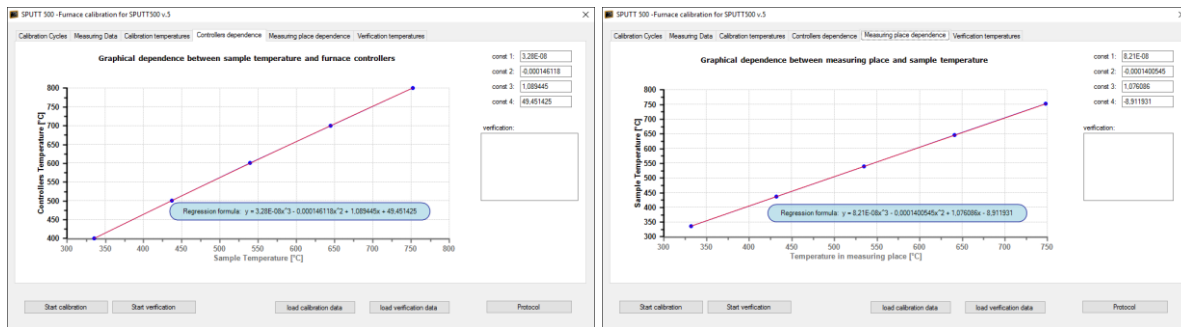

Figures 11, 12, 13 and 14. Screens of calibration software.

### 3. Test results and verification

The result of the comparison is the graphical dependence between the measured and the actual sample temperature (Fig.15), the measured values are given in Table 3.

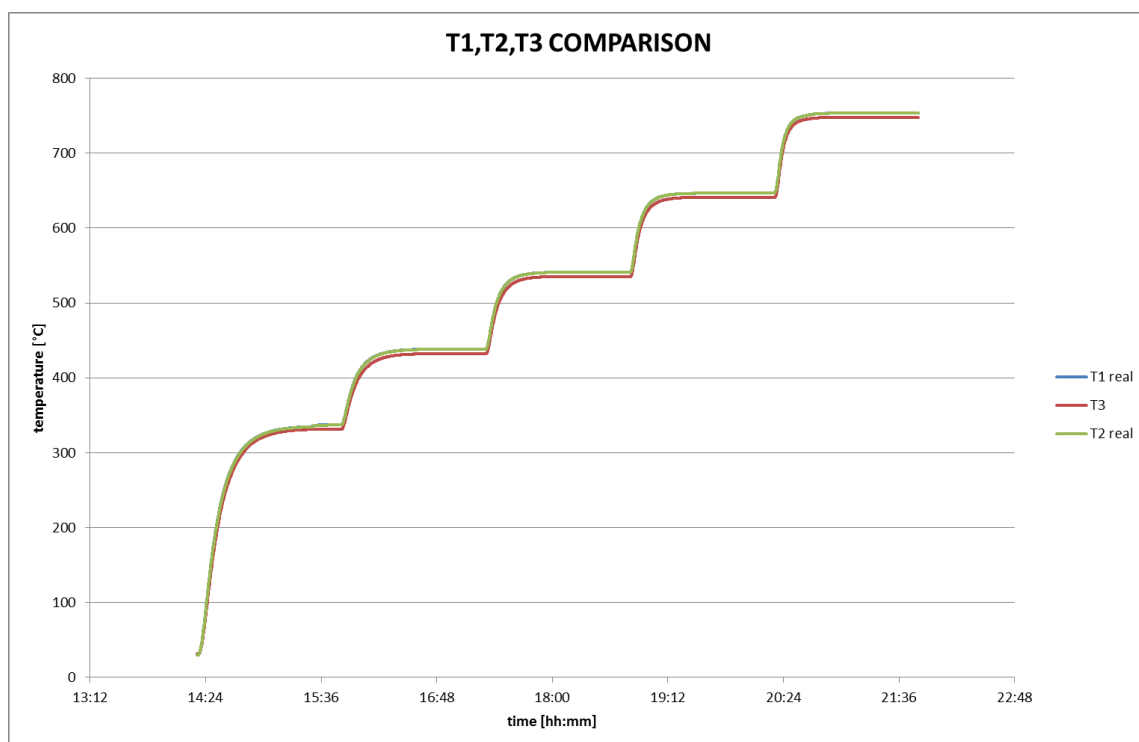

Figure 15. Temperature curves for measured points.

Table 3. Measured and calculated values obtained in comparative tests.

Test Nr.	Tcontroller [°C]	T 1 [°C]	T 2 [°C]	∅ (T1, T2) [°C]	T3 [°C]	Tdif [°C]	Tdif avg [°C]
I	400	337.4	337.1	337.25	331.8	5.45	6.19
	500	438.5	438.2	438.35	431.8	6.55	
	600	541.1	541.1	541.1	534.8	6.3	
	700	646.7	646.7	646.7	640.6	6.1	
	800	753.6	753.5	753.55	747	6.55	
II	400	336.9	337	336.95	331.6	5.35	6.16
	500	437.9	438.1	438	431.7	6.3	
	600	541.2	541.3	541.25	534.5	6.75	
	700	646.2	646.5	646.35	640.7	5.65	
	800	753.8	753.5	753.65	746.9	6.75	
III	400	337.1	337.2	337.15	331.9	5.25	6.1

	500	438.2	438.4	438.3	431.9	6.4	
	600	541.3	541.4	541.35	534.5	6.85	
	700	646.5	646.6	646.55	641	5.55	
	800	753.9	753.4	753.65	747.2	6.45	
IV	400	337.8	337.6	337.7	331.7	6	6.18
	500	438.7	438.8	438.75	432.1	6.65	
	600	541.5	541.7	541.6	535	6.6	
	700	646.7	646.3	646.5	641.1	5.4	
V	400	337.3	337.2	337.25	331.9	5.35	6.23
	500	438.4	438.4	438.4	431.9	6.5	
	600	541.5	541.4	541.45	534.7	6.75	
	700	646.8	646.9	646.85	640.7	6.15	

**Table 4.** Average result values.

Tcontroller [°C]	∅ (T1, T2) [°C]	∅ T3 [°C]	Tdif [°C]	Tdif avg [°C]
400	337,26	331,78	5,48	6,17
500	438,36	431,88	6,48	
600	541,35	534,7	6,65	
700	646,59	640,82	5,77	
800	753,52	747,04	6,48	

The relation between actual (T1,T2) and measured temperature value (T3) was obtained by mathematical interpolation (1).

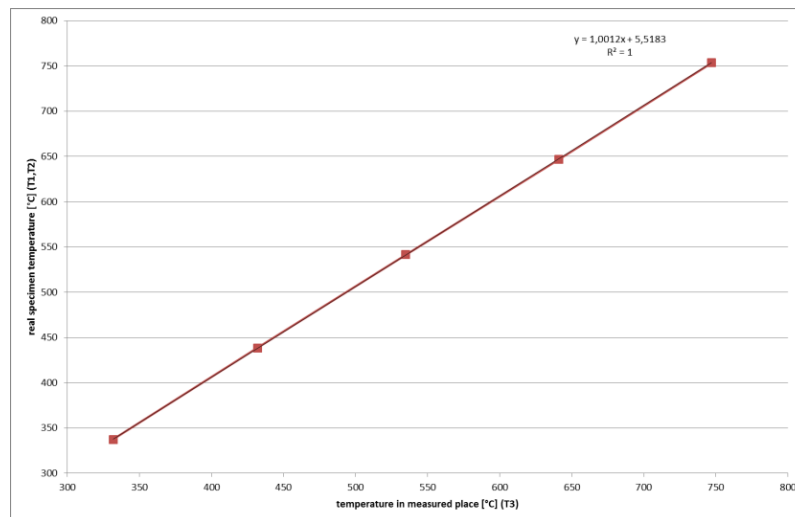
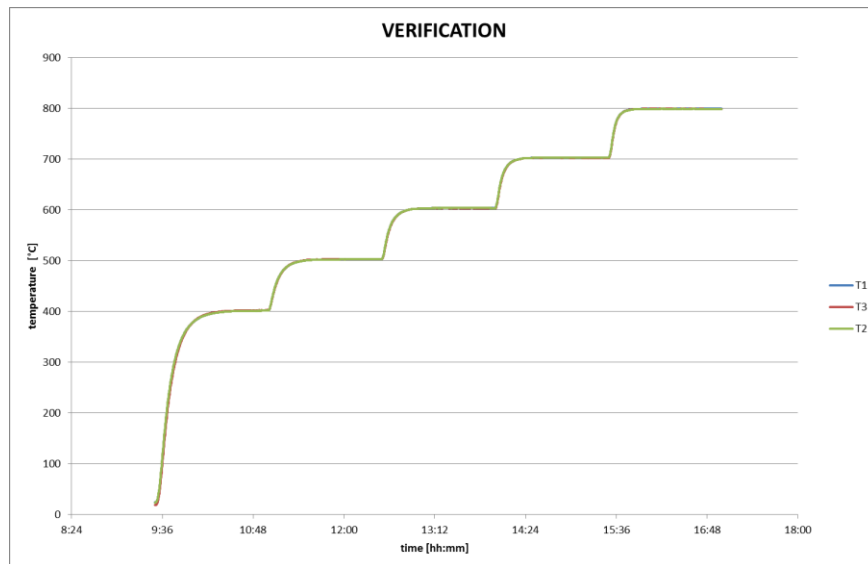

**Figure 16.** Graphical dependence of real specimen temperature (T1, T2) and measured one (T3).

$$y = 1.0012x + 5.5183 \quad (1)$$

The constants of the above-mentioned dependence (1) of the actual specimen temperature on the measured one were entered into the calculation and subsequently verified by the test. The graphical temperature curve is shown in Fig. 17. In tab. 5 it is possible to see the temperature comparison at the set temperature levels.





**Figure 17.** Temperature curves for measured points measured in verification process.

**Table 5.** Measured values found during verification.

Tnominal [°C]	Tcontroller [°C]	Ø (T1.T2) [°C]	T3 [°C]	Tdif [°C]	Tdif avg [°C]
400	461	399.3	399.8	-0.5	0.1
500	558	500.2	500.3	-0.1	
600	653	600.3	599.9	0.4	
700	748	700.1	699.8	0.3	
800	842	799.2	798.9	0.3	

#### 4. Discussion

From the results obtained (Table 4) it is clear that the average difference between the actual and the measured temperature of the test sample is 6.17 °. The measured value is higher than allowed in the TC 101WI draft (Table 6).

**Table 6.** Permitted deviations between  $T_i$  and  $T$ .

Specified test temperature, $T$ °C	Permitted deviation between $T_i$ and $T$ °C
$T < 600$	$\pm 2$
$600 < T \leq 800$	$\pm 3$
$800 < T \leq 1\ 000$	$\pm 4$
$1\ 000 < T \leq 1\ 100$	$\pm 5$

Therefore, the measured temperature value needs to be corrected using mathematical interpolation. The kind of mathematical interpolation depends on the actual accuracy of the measuring thermocouple (type S), which is firmly embedded in the machine system and whose characteristics can be changed over time. In the control system of the SP creep machine SPUTT 500, it was therefore added the possibility of adjusting the dependence of the measured temperature transduction to the actual temperature, in addition to the linear interpolation, as well as the polynomial of the first and the second degree.

In all five tests, the difference between the temperature of the upper (T1) and the lower surface (T2) was less than 0.3 ° C, so the temperature of the upper and lower surface of the sample is almost the same. With regular verification, it is sufficient for the calibration thermocouple to have only one weld point.

Considering the consistency of the measured results, the temperature measurement system must be periodically calibrated not only at regular intervals, but also when the system configuration is changed, such as the change in the pressure of the measuring thermocouple, the change in the preload, the change of the die, punch material etc.

## **5. Conclusion**

Performed tests clearly showed that it is not possible to carry out the small punch creep testing without proper calibration of the specimen temperature heating system. Furthermore, the proposed and approved method is fully functional and can be used regularly and repeatedly. The implemented system allows calibration and subsequent verification of the SPUTT 500 temperature measuring system with an accuracy of  $\pm 1^\circ \text{C}$  up to 800 °C.

## **Acknowledgments**

This work was performed under the support of Project No. LO1203 ‘Regional Materials Science and Technology Centre - Feasibility Program’ funded by the Ministry of Education, Youth and Sports of the Czech Republic

## **References**

1. CEN WORKSHOP AGREEMENT ‘Small Punch Test method for Metallic Materials’ CWA 15627:2007 D/E/F, December 2007
1. ECISS/TC 101 ‘Metallic Materials – Small punch test method’, European Standard - Working Document, AFNOR, December 2017.