

Washington University in St. Louis

## Washington University Open Scholarship

---

Mechanical Engineering Design Project Class

Mechanical Engineering & Materials Science

---

Fall 2023

### **MEMS 411: Heavy Cart Ramp Assistant**

Ethan Current

*Washington University in St. Louis*

Kevin Xiong

*Washington University in St. Louis*

Nick Zanchi

*Washington University in St. Louis*

Follow this and additional works at: <https://openscholarship.wustl.edu/mems411>



Part of the [Mechanical Engineering Commons](#)

---

#### **Recommended Citation**

Current, Ethan; Xiong, Kevin; and Zanchi, Nick, "MEMS 411: Heavy Cart Ramp Assistant" (2023).

*Mechanical Engineering Design Project Class*. 216.

<https://openscholarship.wustl.edu/mems411/216>

This Final Report is brought to you for free and open access by the Mechanical Engineering & Materials Science at Washington University Open Scholarship. It has been accepted for inclusion in Mechanical Engineering Design Project Class by an authorized administrator of Washington University Open Scholarship. For more information, please contact [digital@wumail.wustl.edu](mailto:digital@wumail.wustl.edu).



Washington University in St. Louis

JAMES MCKELVEY SCHOOL OF ENGINEERING

## Mechanical Engineering Design Project

MEMS 411, Fall 2023

### Heavy Cart Ramp Assistant

For this project, group G has been asked to manufacture a device capable of lifting heavy loads of approximately 1500 pounds for Professor Flores's research laboratory at Washington University in St. Louis. This device is meant to function in the laboratory environment lifting large containers that contain gas, with the lab having minimal space for large machinery. Currently, the heavy tank of gas rests on a platform supported by 4 wheels. In order to accurately calculate the amount of gas within the container, two people must maneuver the tank on to a large scale located on the ground. The scale is a raised platform with a shallow ramp so objects may be rolled on to the platform. Moving the tank is dangerous for students or professors, as attempting to push the heavy container up the ramp could lead to it sliding back down. This could injure individuals behind that are supporting the load. If people manage to push the container on to the scale, the momentum of the tank crashes it in to the wall located behind the scale. This is not ideal as it poses a safety hazard and damages the laboratory/tank. Our goal is to construct a frame that will house an electric winch. This frame will be fixed behind the scale that the tank sits on. This automation and control of the heavy object allows for less people to operate the machinery, making the task safer and easier.

Xiong, Kevin  
Zanchi, Nick  
Current, Ethan

# Contents

<b>List of Figures</b>	<b>2</b>
<b>List of Tables</b>	<b>2</b>
<b>1 Introduction</b>	<b>3</b>
<b>2 Problem Understanding</b>	<b>3</b>
2.1 Existing Devices . . . . .	3
2.2 Patents . . . . .	6
2.3 Codes & Standards . . . . .	8
2.4 User Needs . . . . .	9
2.5 Design Metrics . . . . .	10
2.6 Project Management . . . . .	10
<b>3 Concept Generation</b>	<b>12</b>
3.1 Mockup Prototype . . . . .	12
3.2 Functional Decomposition . . . . .	14
3.3 Morphological Chart . . . . .	16
3.4 Alternative Design Concepts . . . . .	17
<b>4 Concept Selection</b>	<b>21</b>
4.1 Selection Criteria . . . . .	21
4.2 Concept Evaluation . . . . .	21
4.3 Evaluation Results . . . . .	22
4.4 Engineering Models/Relationships . . . . .	22
<b>5 Concept Embodiment</b>	<b>24</b>
5.1 Initial Embodiment . . . . .	24
5.2 Proofs-of-Concept . . . . .	28
5.3 Design Changes . . . . .	28
<b>6 Design Refinement</b>	<b>28</b>
6.1 Model-Based Design Decisions . . . . .	28
6.2 Design for Safety . . . . .	29
6.3 Design for Manufacturing . . . . .	32
6.4 Design for Usability . . . . .	33
6.5 Design Considerations . . . . .	33
<b>7 Final Prototype</b>	<b>35</b>
7.1 Overview . . . . .	35
7.2 Documentation . . . . .	35
<b>Bibliography</b>	<b>36</b>

## List of Figures

1	All Terrain Pallet Truck (Source: Platforms and Ladders) . . . . .	4
2	Hydraulic Lift (Source: Spinlife) . . . . .	5
3	Winch (Source: Amazon) . . . . .	6
4	Patent Images for winch assembly . . . . .	7
5	Patent Images for pallet jack . . . . .	8
6	Gantt chart for design project . . . . .	11
7	Prototype view 1 . . . . .	12
8	Prototype view 2 . . . . .	13
9	Prototype view 3 . . . . .	14
10	Function tree for crank system, hand-drawn and scanned . . . . .	15
11	Morphological Chart for Crank system . . . . .	16
12	Sketches of winch concept . . . . .	17
13	Sketches of winch concept 2 . . . . .	18
14	Sketches of winch concept 3 . . . . .	19
15	Sketches of winch concept 4 . . . . .	20
16	Analytic Hierarchy Process (AHP) to determine scoring matrix weights . . . . .	21
17	Weighted Scoring Matrix (WSM) for choosing between alternative concepts . . . . .	21
18	Equation for Rolling Friction . . . . .	22
19	Incline Plane Diagram of Ramp . . . . .	23
20	Pulley model diagram . . . . .	24
21	Assembled projected views with overall dimensions . . . . .	25
22	Large isometric view of assembly at a different angle . . . . .	26
23	Exploded view with callout to BOM . . . . .	27
24	Risk Heat Map . . . . .	31
25	Current Prototype Device . . . . .	32
26	Final Prototype Device . . . . .	35

## List of Tables

1	Interpreted Customer Needs . . . . .	9
2	Target Specifications . . . . .	10
3	Factors considered for design solution . . . . .	33
4	Contexts considered for ethical judgments . . . . .	34



# 1 Introduction

For this project, a device that is capable of lifting the gas tank is ideal. Avoidance of ramp use would minimize the safety risks that this process currently poses. This would also allow for only one person to be necessary for device operation, since two individuals were originally required to support the load up the ramp.

Given the weight must be measured accurately, the device should not affect the readings of the scale. It should be able to be removed once the gas tank is set on the scale. The device should also be designed to be minimal in size, as free space in the laboratory is limited. [1].

## 2 Problem Understanding

### 2.1 Existing Devices

These three devices outline some of the ideas we thought of when designing our device. Each apparatus contains some sort of mechanism that is meant to transport a heavy load, such as the Argon tank we will be dealing with for this project.

### 2.1.1 Existing Device #1: All Terrain Pallet Truck



Figure 1: All Terrain Pallet Truck (Source: Platforms and Ladders)

Link: <https://www.platformsandladders.com/pallet-trucks-tuggers/all-terrain-pallet-trucks>

Description: The All Terrain Pallet Truck is designed like a normal pallet jack, however instead of having small wheels built in to the prongs, it contains larger wheels around the prongs designed for handling different terrains. This device is meant to easily transport heavy loads from one destination to another. This device has a lever meant to manually jack the load. The trigger on the inside of the handle is meant to be squeezed in order to lower the load at its destination.

## 2.1.2 Existing Device #2: Hydraulic Lift



Figure 2: Hydraulic Lift (Source: Spinlife)

Link: <https://www.spinlife.com/Invacare-Hydraulic-Lift-w/Adjustable-Base-Manual-Patient-Lift/spec.cfm?productID=82296>

Description: The Hydraulic Lift is designed for a medical environment. It is used to comfortably lift patients up and transport them wherever they need to go. This device is also designed to be able to rotate 360 degrees so that once the load is lifted, maneuvering it isn't an issue. The 4 roller wheels on the bottom allow for this maneuverability, as well as the rotating hooks at the top of the device.

### 2.1.3 Existing Device #3: Winch



Figure 3: Winch (Source: Amazon)

Link: <https://www.amazon.com/Two-Way-Automatic-Portable-Hoisting-Detachable/dp/B09DL8J8TH?th=1>

Description: The Winch is a classic device that hooks on to a heavy load and can pull it towards something. Inversely, A winch can also unreal itself to send the heavy load away. This winch is a mechanical device meant to be reeled in and out by hand. This particular winch is made with a heavy duty woven steel wire, designed to withstand a significant amount of tension due to heavy loads.

## 2.2 Patents

### 2.2.1 Winch Assembly (US011485617B2)

This patent describes their design layout for a winch assembly which contains a lower body having a base, two sides, two upper body sides, a spacer between the first and upper second side, a shaft

supporting first and second gears, a bar connecting the first shaft and strap, second shaft extending through upper body and supporting ratchet gears, first ratchet gear meshed with first gear and likewise with second gears, pawl for engaging ratchet gears, and handle for rotation attached to second shaft.

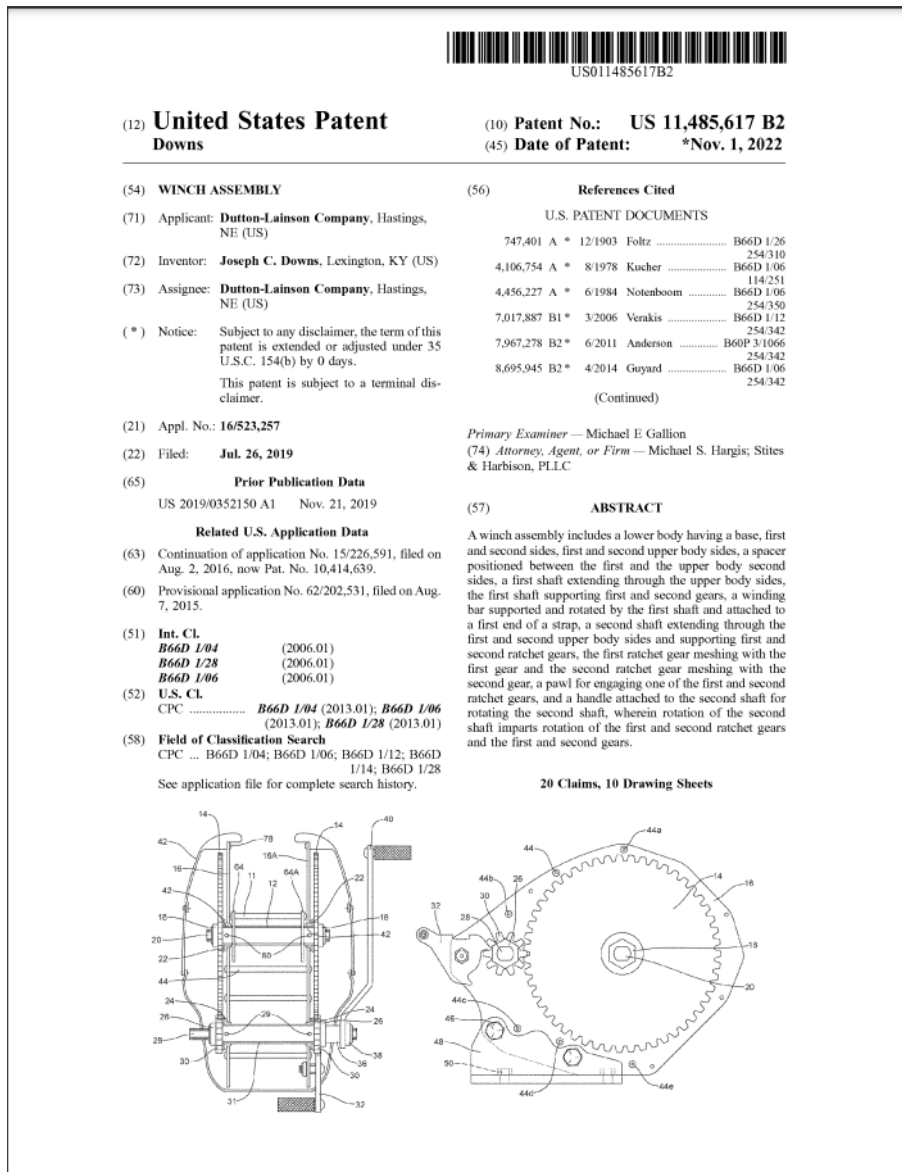

Figure 4: Patent Images for winch assembly

## 2.2.2 Adjustable Span Tine Pallet Jack (US20230278612A1)

This patent is for a pallet jack that has a base and a pair of tines that extend from the base, the base includes a lifting mechanism, a load wheel that supports an end of each tine, each wheel able to move toward and away from its respective tine to raise/lower it, and each tine including a support surface to be the lowermost surface of the tine to facilitate lateral displacement.



US 20230278612A1

(19) **United States**  
(12) **Patent Application Publication** (10) **Pub. No.: US 2023/0278612 A1**  
Kalinowski (43) **Pub. Date: Sep. 7, 2023**

(54) **ADJUSTABLE SPAN TINE PALLET JACK** **Publication Classification**  
(71) Applicant: **Rehrig Pacific Company**, Los Angeles, CA (US) (51) **Int. Cl.**  
*B62B 3/06* (2006.01)  
*B66F 7/06* (2006.01)  
*B66F 9/12* (2006.01)  
(72) Inventor: **Dane Gin Mun Kalinowski**, Foothill Ranch, CA (US) (52) **U.S. Cl.**  
CPC ..... *B62B 3/0625* (2013.01); *B66F 7/0641* (2013.01); *B66F 9/12* (2013.01); *B62B 3/06* (2013.01); *B62B 3/0618* (2013.01); *B62B 2203/10* (2013.01); *B62B 2203/20* (2013.01); *B62B 2301/02* (2013.01); *B62B 3/0612* (2013.01)  
(21) Appl. No.: **18/196,135**  
(22) Filed: **May 11, 2023**

**Related U.S. Application Data** (57) **ABSTRACT**  
(60) Continuation of application No. 17/583,405, filed on Jan. 25, 2022, now Pat. No. 11,683,417, which is a division of application No. 17/226,194, filed on Apr. 9, 2021, now Pat. No. 11,260,890, which is a continuation of application No. 16/800,169, filed on Feb. 25, 2020, now Pat. No. 10,988,155.  
(60) Provisional application No. 62/884,000, filed on Aug. 7, 2019, provisional application No. 62/810,308, filed on Feb. 25, 2019.

A pallet jack includes a base and a pair of tines extending from the base. The pair of tines including a first tine and a second tine. A load wheel supports an outer end of each of the pair of tines. Each load wheel is configured to move toward and away from the respective tine to raise the tine off a floor on which the load wheel is supported. The first tine including a support surface configured to selectively be a lowermost surface of the tine to facilitate lateral displacement of the first tine.

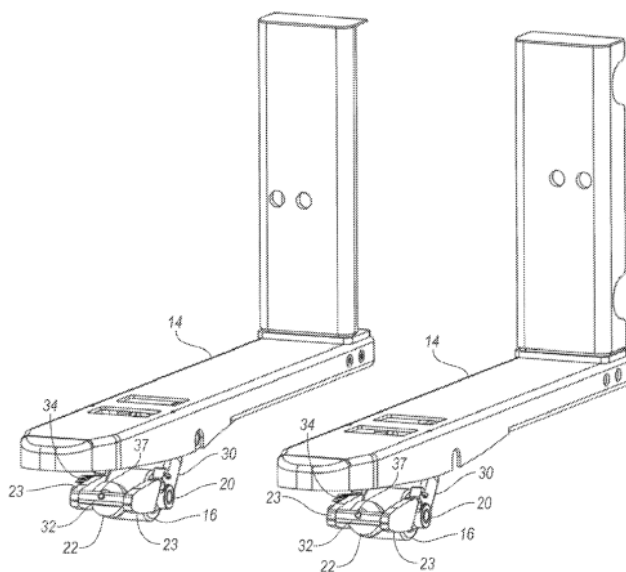

Figure 5: Patent Images for pallet jack

## 2.3 Codes & Standards

### 2.3.1 Compressed Gases and Cryogenic Fluids Code (NFPA 55)

This code from the National Fire Protection Association provides safety requirements for storage, use, and handling of compressed gases and cryogenic fluids in portable or stationary containers. Since our project involves the transport of a heavy gas cylinder, our device must abide by the requirements set to ensure safety for operating personnel and the laboratory space.

### 2.3.2 Below-the-Hook Lifting Devices (ASME B30.20)

This ASME code provides safety requirement for marking, construction, installation, inspection, testing, maintenance, and operation of below-the-hook lifting devices. Given that our device could resemble a hydraulic lift (shown by section 2.1.2) these standards will guide the design process to provide an apparatus capable of performing its task efficiently and is capable of withstanding many rounds of use.

## 2.4 User Needs

These are the things the customer outlined our product needed to do/have:

### 2.4.1 Customer Interview

Interviewee: Katherine Flores

Location: Jubel 020, Washington University in St. Louis, Danforth Campus

Date: September 8<sup>th</sup>, 2023

Setting: We met in the basement of Jubel along with one other group. Flores took us into the lab and gave us an outline of the issue and how she would like it to be resolved. The whole interview was conducted in the lab where the Argon tank was located, and took ~30 min.

Interview Notes:

*Are all of the tanks that come in identical to one another or do they vary?*

- The size of the tanks is consistent but the tops do vary.

*Would you prefer the device we make to be portable?*

- Yes, I would prefer it to be portable/ able to fold up and be stored. I mainly want the device to be out of the way from everything.

*How heavy is a full Argon tank?*

- Our scale maxes out at 1000 lbs, and a full tank maxes out our scale so if we were to guess, probably ~1200 lbs.

Note: we later found a similar tank online that claimed max weight was 1,200 lbs.

### 2.4.2 Interpreted User Needs

Below is a table of certain needs listed by Flores during the interview. Their importance is ranked on the right from a scale of 1-5, 1 being not important and 5 being very important.

Table 1: Interpreted Customer Needs

Need Number	Need	Importance
1	The device is portable	4
2	The device doesn't get in the way	5
3	The device can support the weight of the tank	5
4	The device only requires 1 person to operate	5
5	The device is aesthetically pleasing	1
6	The device isn't noisy	2
7	The device is durable	4

After the interview we got a better idea of how to construct our device based on the needs of Flores. We will be prioritizing the needs ranked the highest while making our device, but also keeping the other, less important needs in the back of our heads.

## 2.5 Design Metrics

This table is a rough estimate of design constraints for our device to have based on the needs of the customer.

Table 2: Target Specifications

Metric Number	Associated Needs	Metric	Units	Acceptable	Ideal
1	1,2	Total weight	lbs	40	20
2	1,2	Total volume	$ft^3$	$< 8$	$< 5$
3	3,7	Total weight device can support	avg. score	1200	1500
4	4	Force required to turn crank	lbs	20	15
5	5	Number of parts	integer	20	15
6	6	Amount of noise produced	decibels	100	85
7	7	Parts need to withstand the stress and fatigue it goes under	binary	pass	pass

## 2.6 Project Management

The Gantt chart in Figure 6 gives an overview of the project schedule.



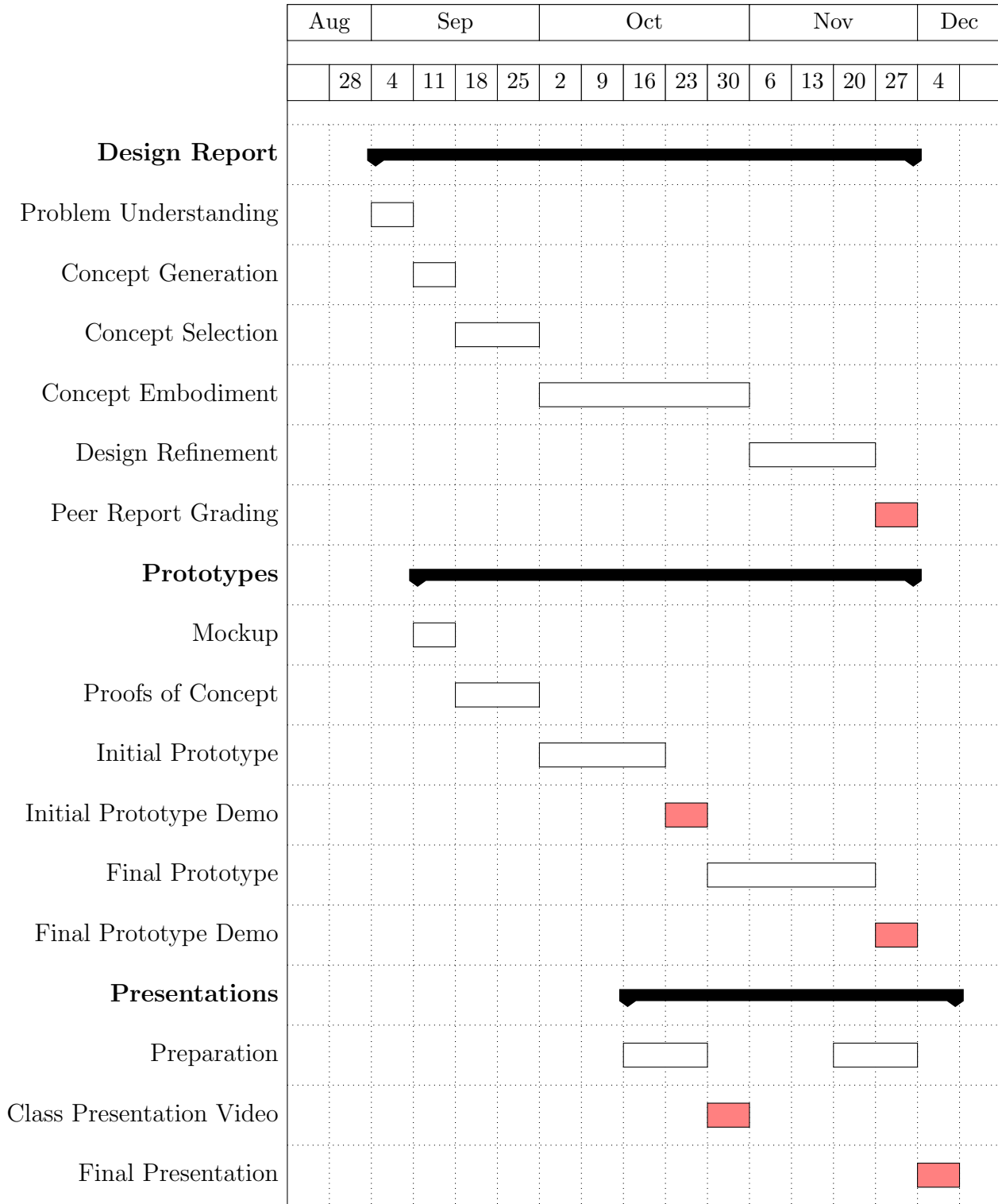

Figure 6: Gantt chart for design project

### 3 Concept Generation

#### 3.1 Mockup Prototype

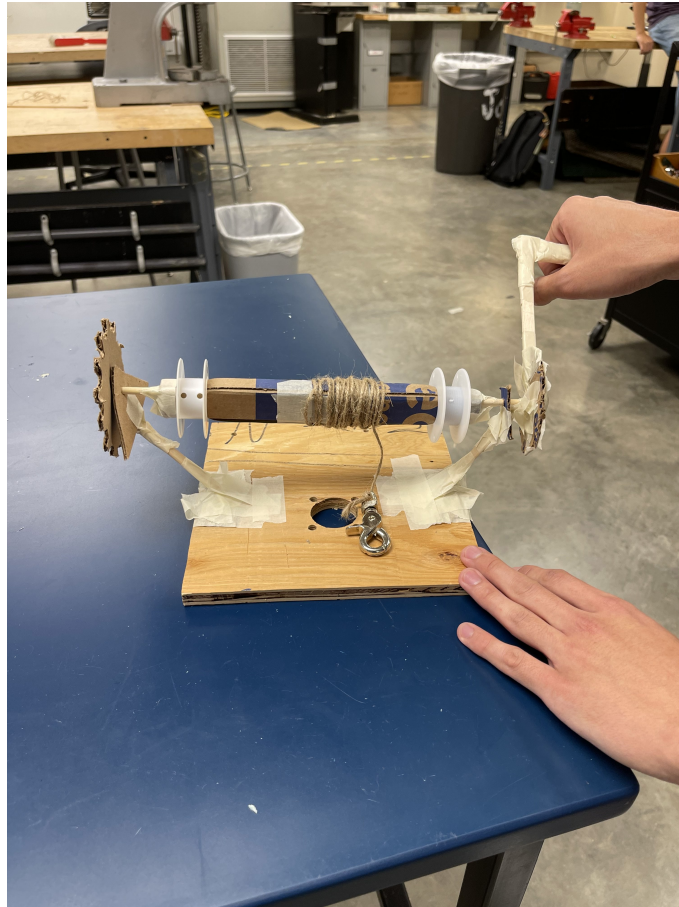

Figure 7: Prototype view 1



Figure 8: Prototype view 2

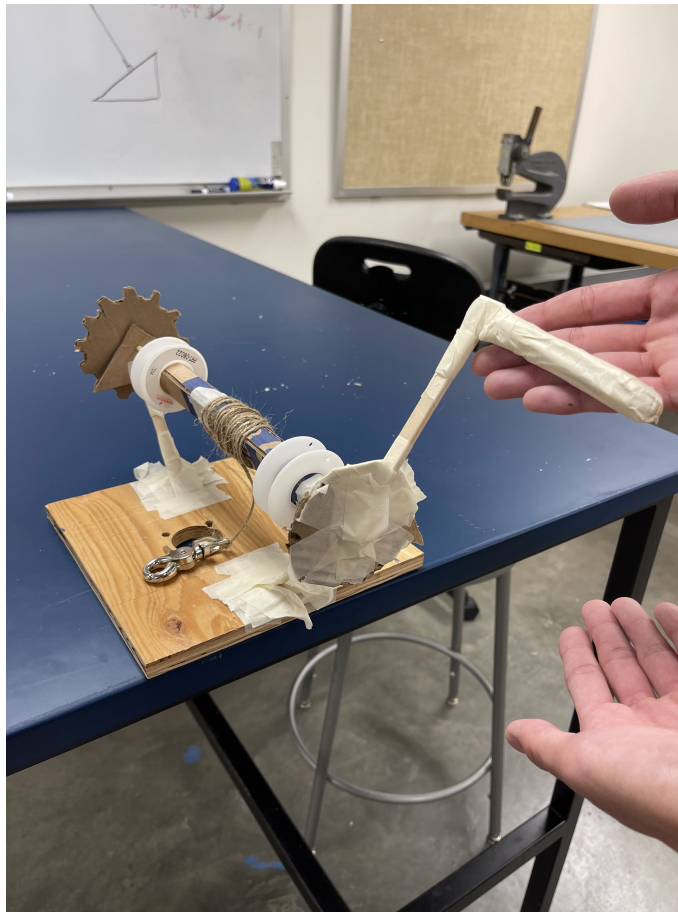

Figure 9: Prototype view 3

This mockup changed our perspective on how we were gonna make our device. There were a lot of small problems we ran into when creating this mockup such as getting the handle to turn the shaft without falling off, as well as keeping the shaft from slipping. We inserted a small wooden rod to support the shaft but should have tapped or glued it to the inside of the cardboard shaft. These are minor problems, however, and we shouldn't run into these when creating our actual design since we will be using better materials. It did make us think ahead on how we were going to go about constructing each part of the winch.

### 3.2 Functional Decomposition

In order to get an idea of all the different parts our device would need to successfully get the Argon tank up the ramp, this function tree was created and divided our overall function into smaller subfunctions which helped us generate our morphological chart.

# Function Tree

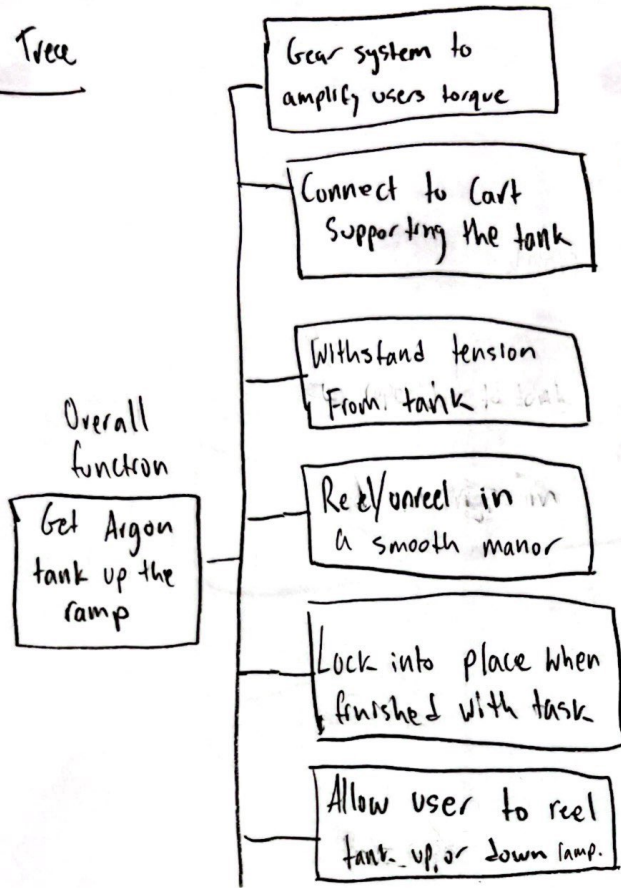

CS Scanned with CamScanner

Figure 10: Function tree for crank system, hand-drawn and scanned



### 3.3 Morphological Chart

Our morphological chart shows our six sub-functions with different types of ideas to solve their respective sub-function.

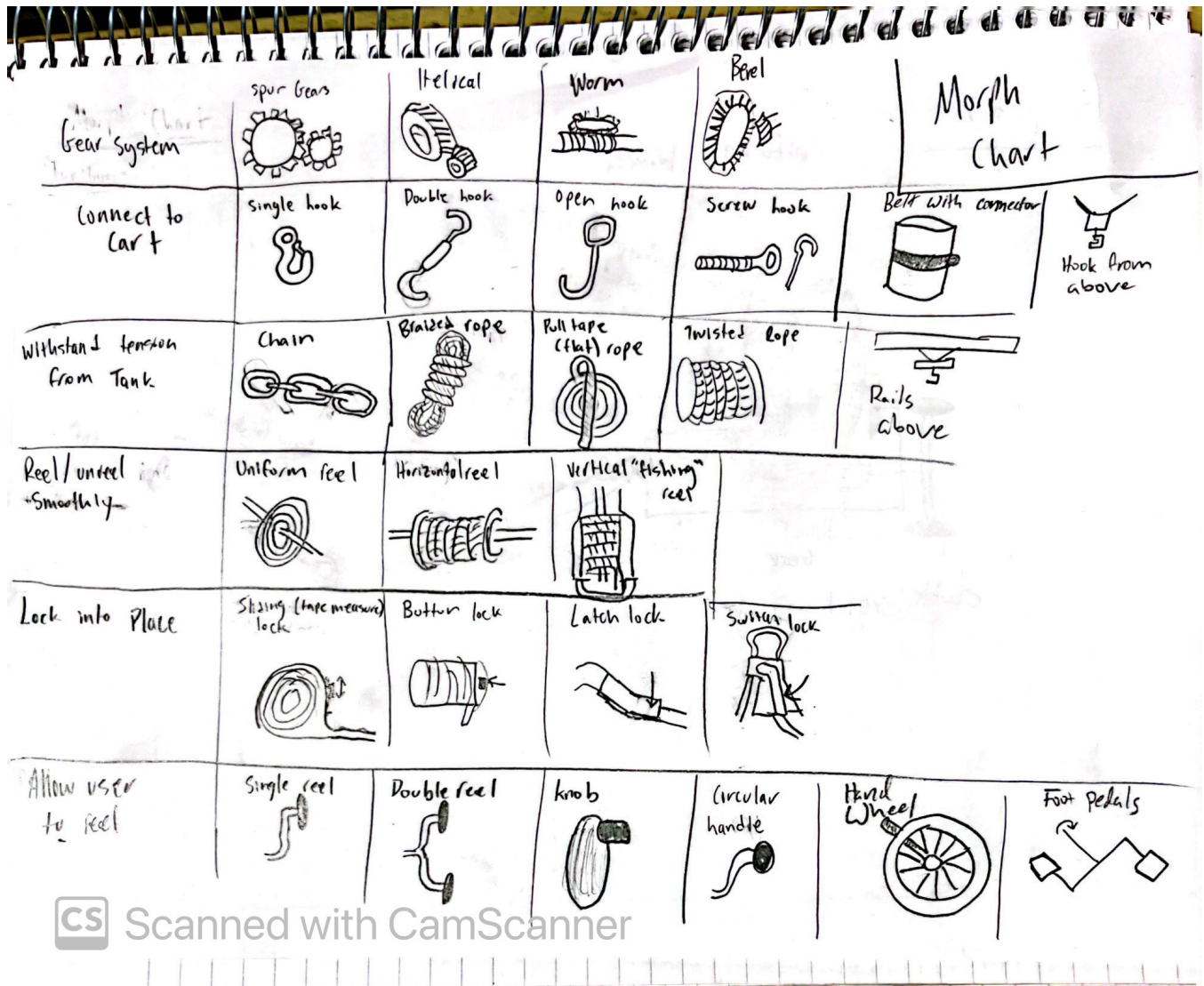

Figure 11: Morphological Chart for Crank system

### 3.4 Alternative Design Concepts

#### 3.4.1 Concept #1: "Classic" Winch

Concept #1

"Classic" Winch

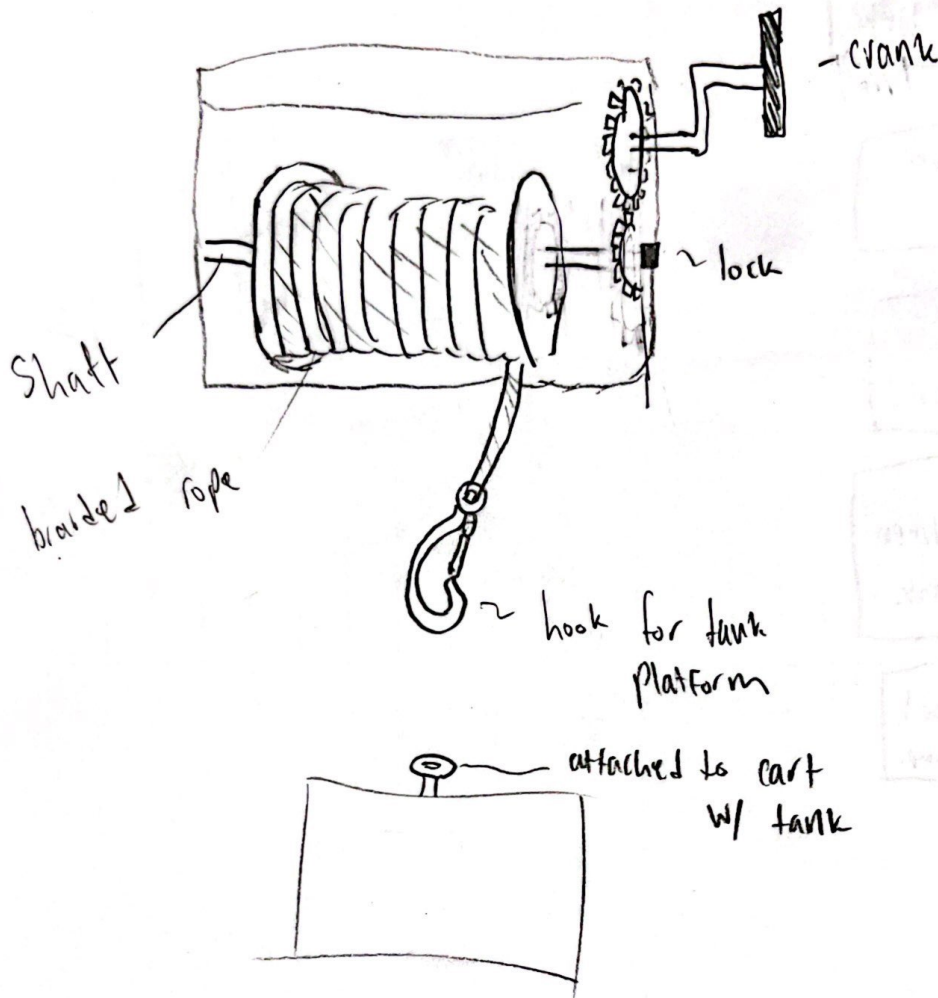

CS Scanned with CamScanner

Figure 12: Sketches of winch concept

Description: This design is inspired by a classic winch. We have a simple hand crank that is connected to 2 gears allowing for torque amplification. This crank turns the shaft which winds the

rope, pulling up our Argon tank. The tank will be attached with some sort of loop that will connect to a hook at the end of our rope.

### 3.4.2 Concept #2: "Uniform" Winch

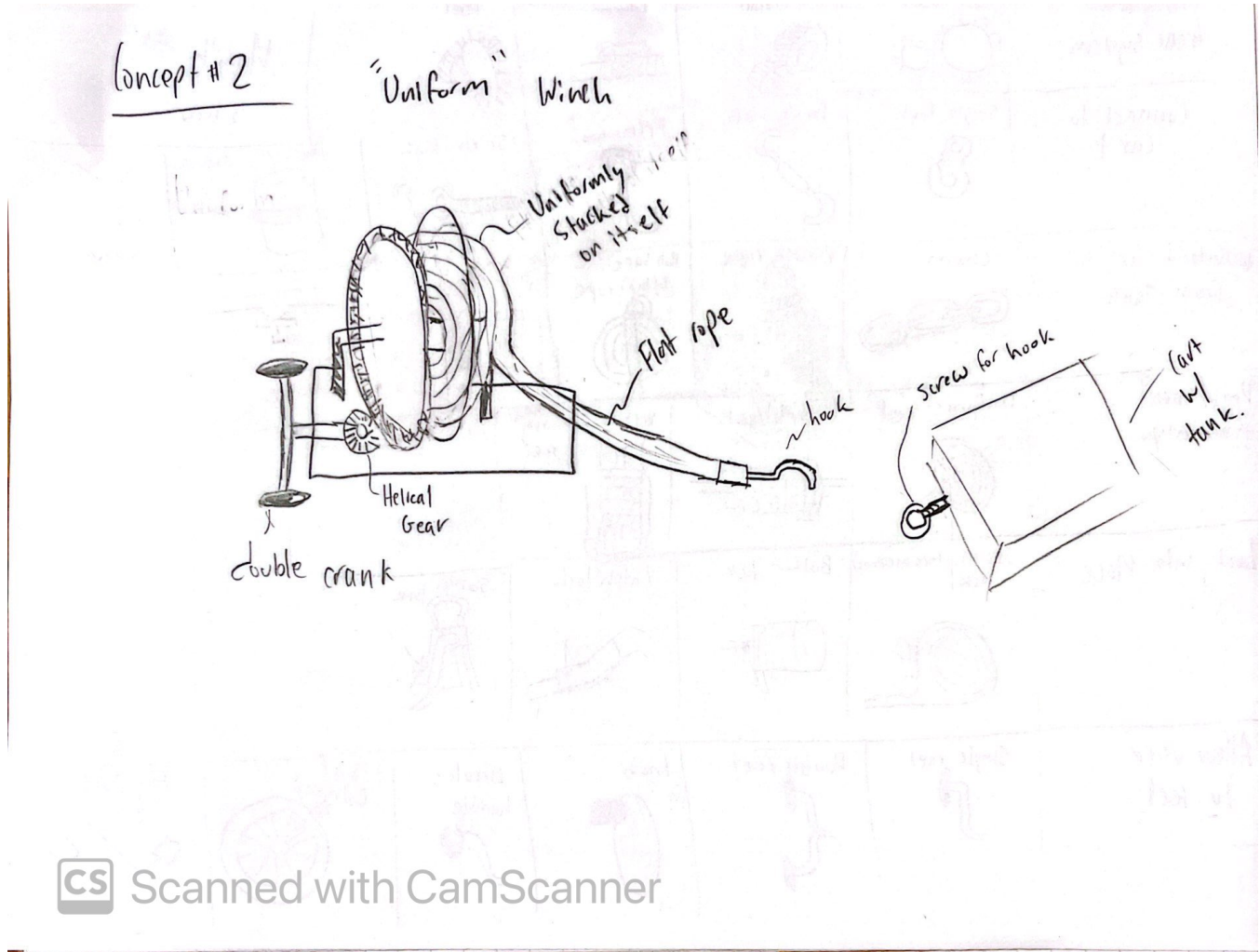

Figure 13: Sketches of winch concept 2

Description: This concept is similar to that of the first one, however we will be using a helical gear system to amplify the users torque output. This device would also have a spindle that winds the rope up ontop of itself like a yo-yo. To make this task easier we will use flat rope as opposed to round rope in order to keep it more uniform and stack on itself neatly. This device will have a similar hook to device 1, hooking onto a circular opening attached to the tank.



### 3.4.3 Concept #3: Spin reel winch

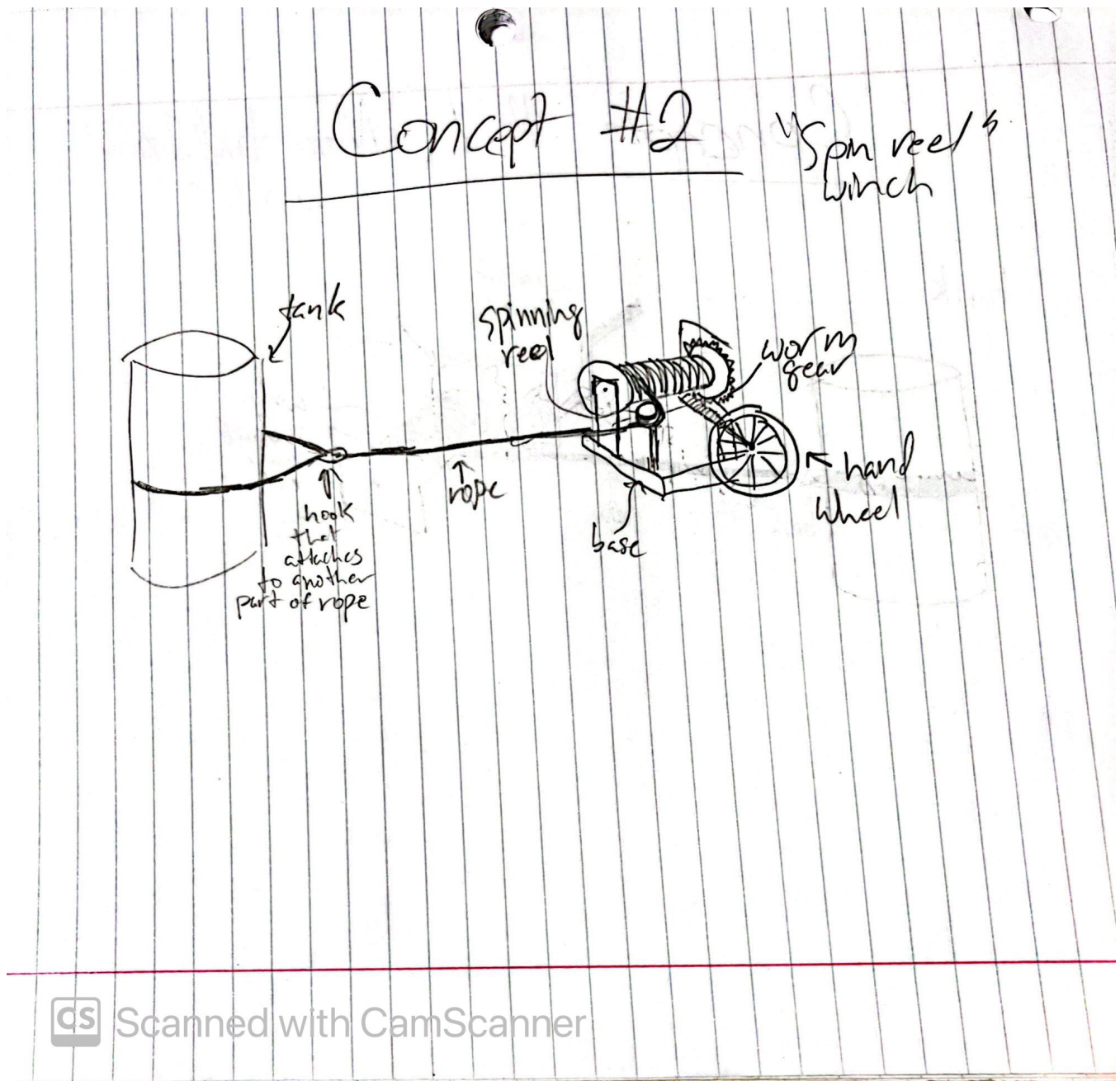

Figure 14: Sketches of winch concept 3

Description: This concept uses a wheel to crank a set of worm gears that winds up the cable in a spinning reel style and attaches to the tank by going around and hooking the cable to itself with a hook.

### 3.4.4 Concept #4: Crane winch system

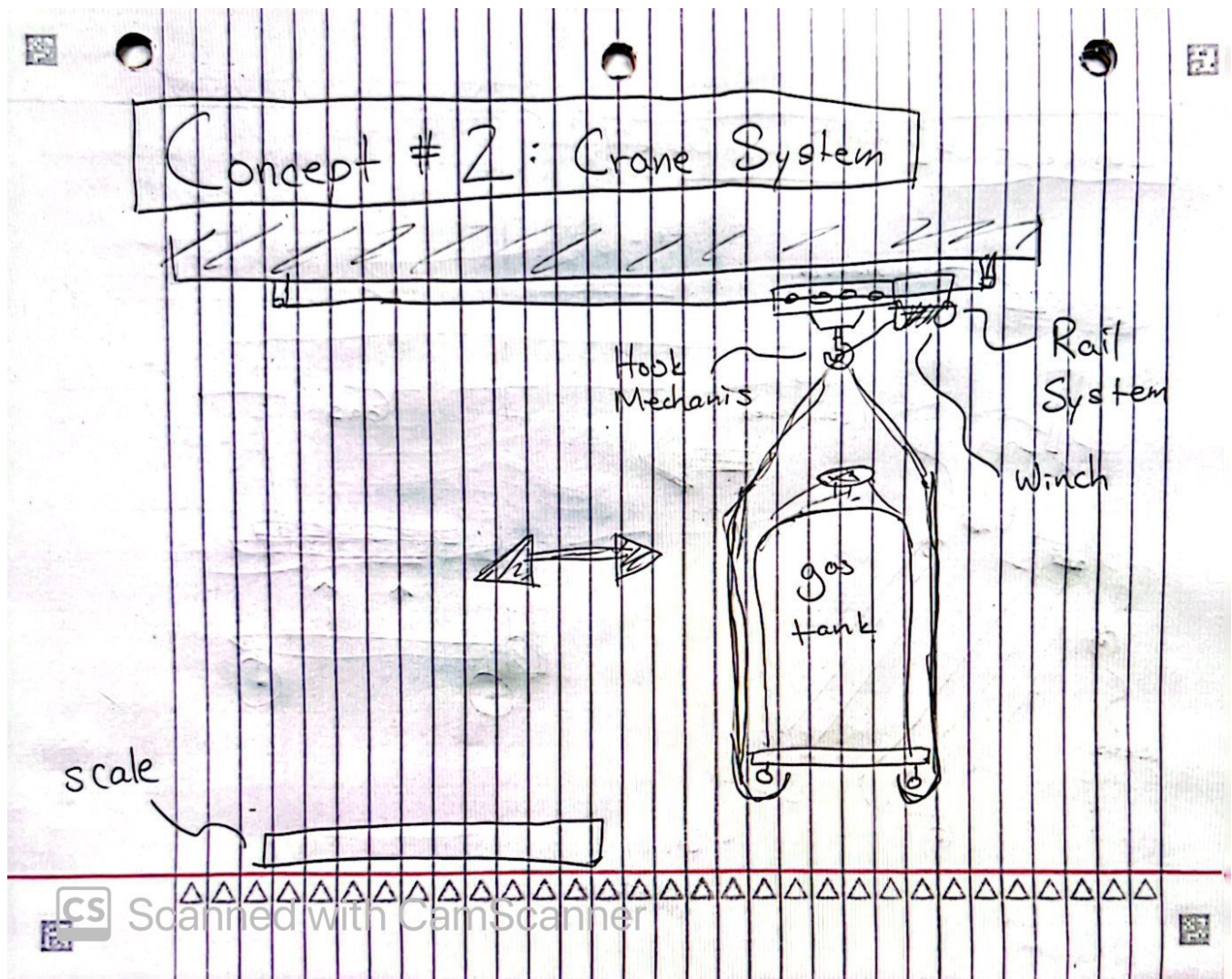

Figure 15: Sketches of winch concept 4

Description: This concept uses a rail to horizontally move the tank onto the scale and uses a winch to crank the tank vertically by attaching the rope to the tank with a hook, then holds in place vertically as it is pushed over the scale.

## 4 Concept Selection

### 4.1 Selection Criteria

Below is an analytical hierarchy process with 5 selected criterion. Each criterion was chosen based on the needs from the interviewer.

	A	B	C	D	E	F	G	H	I	J	
1		Safe to use	Durable	Asthetically Pleasing	Easy to manufacture	Storability		Row Total	Weight Value	Weight (%)	
2	Safe to use	1.00	3.00	9.00	5.00	3.00		21.00	0.38	37.91	
3	Durable	0.33	1.00	7.00	5.00	3.00		16.33	0.29	29.49	
4	Asthetically Pleasaing	0.11	0.14	1.00	0.20	0.20		1.65	0.03	2.99	
5	Easy to manufacture	0.20	0.20	5.00	1.00	0.33		6.73	0.12	12.16	
6	Storability	0.33	0.33	5.00	3.00	1.00		9.67	0.17	17.45	
7											
8		<b>Column Total:</b>							<b>55.39</b>	<b>1.00</b>	<b>100.00</b>

Figure 16: Analytic Hierarchy Process (AHP) to determine scoring matrix weights

### 4.2 Concept Evaluation

This table shows takes the weight percentages from the AHP and the ratings given for each concept to calculate an overall score for each concept as well as ranking them.

Alternative Design Concepts		Concept #1		Concept #2		Concept #3		Concept #4	
		Rating	Weighted	Rating	Weighted	Rating	Weighted	Rating	Weighted
Safe to use	37.91	4	1.52	3	1.14	4	1.52	1	0.38
Durable	29.49	3	0.88	2	0.59	2	0.59	2	0.59
Asthetically pleasing	2.99	4	0.12	2	0.06	3	0.09	3	0.09
Easy to manufacture	12.16	2	0.24	3	0.36	2	0.24	1	0.12
Storability	17.45	4	0.70	3	0.52	3	0.52	3	0.52
	<b>Total score</b>	<b>3.462</b>		<b>2.675</b>		<b>2.963</b>		<b>1.704</b>	
	<b>Rank</b>	<b>1</b>		<b>3</b>		<b>2</b>		<b>4</b>	

Figure 17: Weighted Scoring Matrix (WSM) for choosing between alternative concepts



### 4.3 Evaluation Results

Looking at the results from the analytical hierarchy process, it is clear that our design being safe to use is the most important criterion, with a weight percentage of 37.91. Our next closest criterion is that our design is durable. These two criterion ensure the safety of our user and that the design will last. Storability is important as well, however in order to ensure the durability of our design this won't be our top priority. Manufacturability also doesn't rank as high, as we must meet the top criterion first. Finally our lowest criterion is that our device is aesthetically pleasing. This will be the least of our concerns and will only be considered during the final stages. Looking now at the WSM, the rankings suggest that the concept 1 is our best choice. This is mainly due to its high rating for safety and storability. However, these scores are only estimates and are somewhat difficult to rate due to not being able to test or have physical models.

### 4.4 Engineering Models/Relationships

The following section will discuss different models/relationships that will be considered in our design.

Engineering Model 1: Rolling Friction Kevin Krong  
513049

$$F_{fr} = \frac{Wb}{\sqrt{r^2 - b^2}}$$

$r$  = radius of wheel  
 $b$  = horizontal distance until wheel is not touching bottom surface

⇒ Whether it is manually pushing a heavy container on wheels or a movable hook above the object, frictional forces will be present.  $F_{fr}$  needs to be calculated in order to safely/correctly transport an object.

Figure 18: Equation for Rolling Friction

This equation for rolling friction must be used in consideration of the transportation of the heavy gas tank. We are aware that the heavy gas tank rests on 4 wheels, with a weight of around 1200 pounds. Once radius and  $b$  (the horizontal distance until the wheel is no longer in contact with the ground) of the wheels are known, we can calculate the frictional force. This, among other loads, are taken in to consideration when selecting durable materials such as rope.

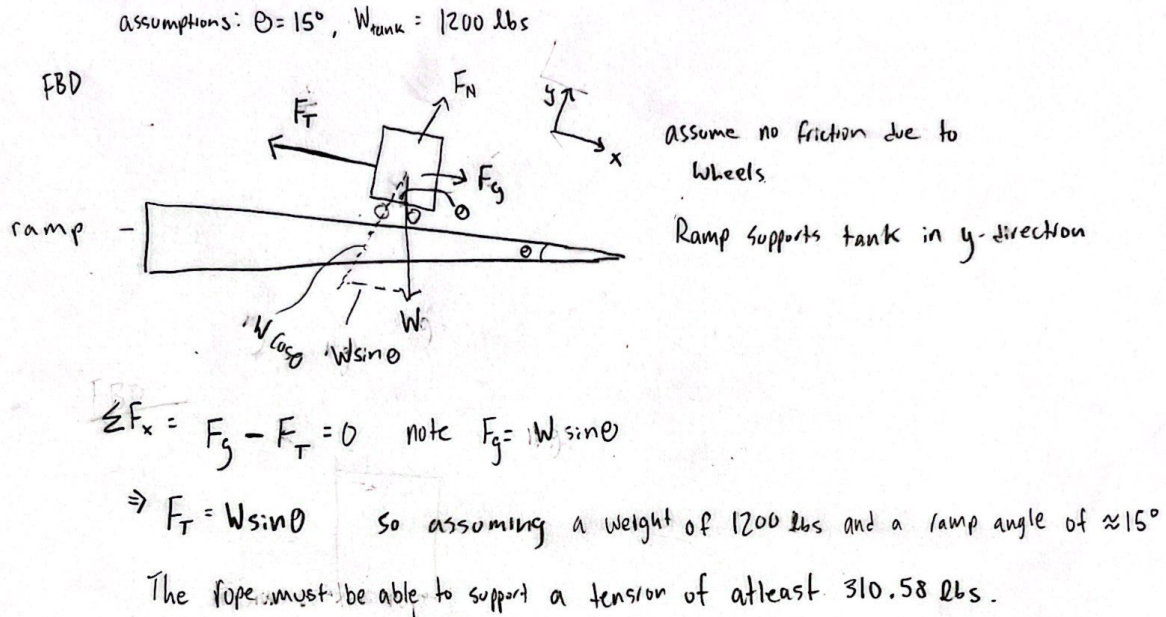

CS Scanned with CamScanner

Figure 19: Incline Plane Diagram of Ramp

In this image the tension force in the rope was calculated by using the inclined plane method. The ramp for the tank was assumed to have an angle of about 15 degrees. The tank was assumed to be 1200 lbs. Since the tank comes on a cart with wheels, the force of friction was assumed to be negligible in this diagram, but can be calculated in figure 18 above. The forces in the  $y$  direction were disregarded, since the normal force of the ramp takes care of that. Thus, solving for the tension that the rope will undergo, we multiply the weight of the tank by sine of 15 degrees. This gives a tension of 310.58 lbs. The rope that we will select must at a minimum support this weight.

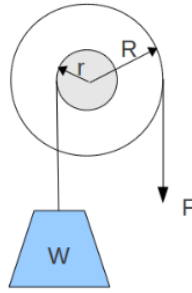

Figure 20: Pulley model diagram

Rope wraps/turns around a smaller radius while a force turns the bigger radius wheel. This gets incorporated into our design by how the rope will wrap around the smaller radius wheel and the bigger radius wheel would actually be a gear for our design with a force applied from a smaller gear and handle. We will need to find the tension that would be in the rope, which is explained in the model before this, that holds the given weight. From there, we will be able to calculate the needed radius and force acting on each gear.

## 5 Concept Embodiment

### 5.1 Initial Embodiment

Our first prototype goal is to hoist the tank 1 foot in 30 seconds maximum when being cranked, as one of our customer needs is that it requires to be done relatively quickly. Our second goal is to only be cranked by 1 user with ease due the need of it only taking one user to get the tank onto the scale. Our third goal is for it to be somewhat portable and able to be stored without getting in the way of anything. Our prototype CAD drawings are shown below.

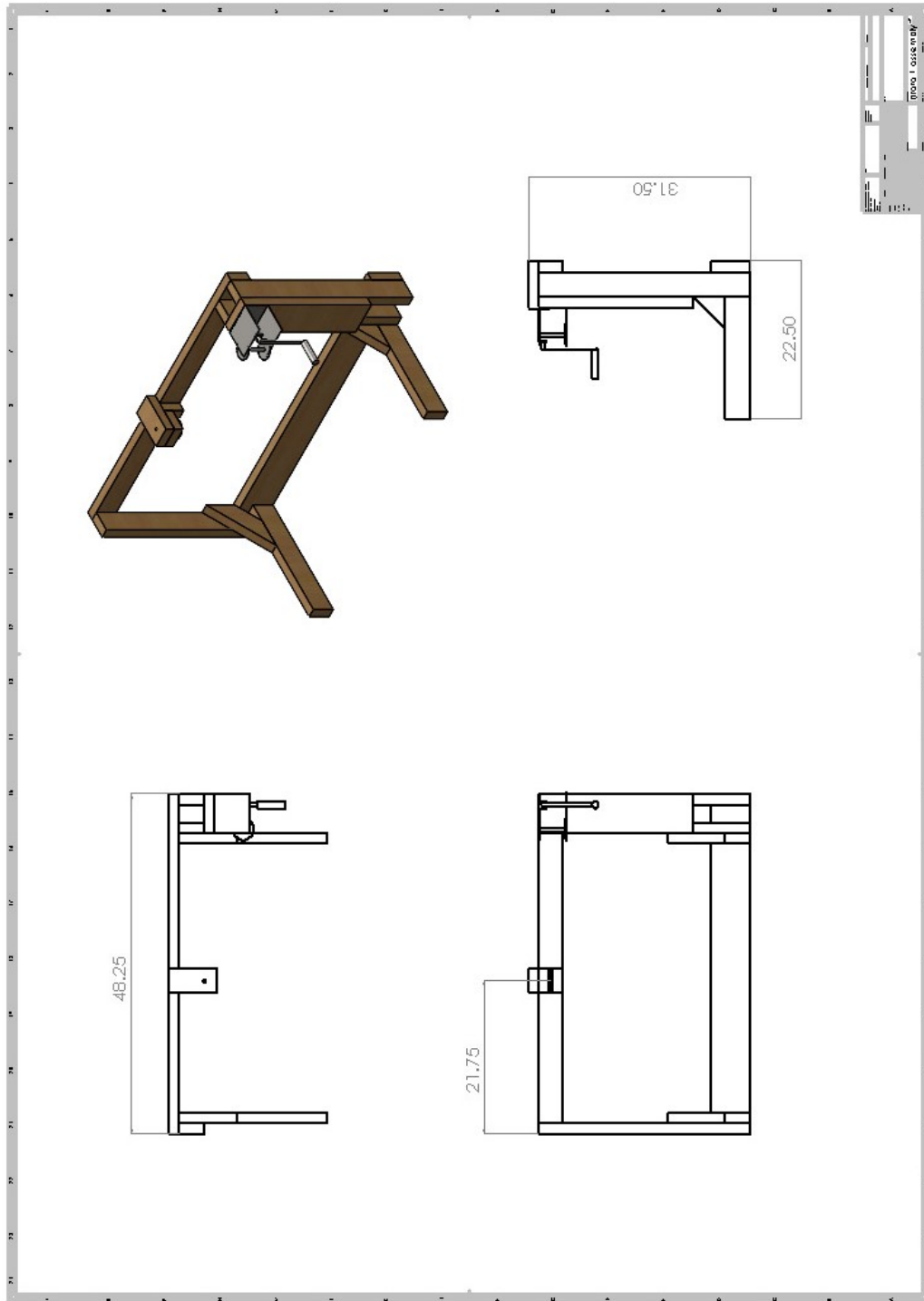

Figure 21: Assembled projected views with overall dimensions

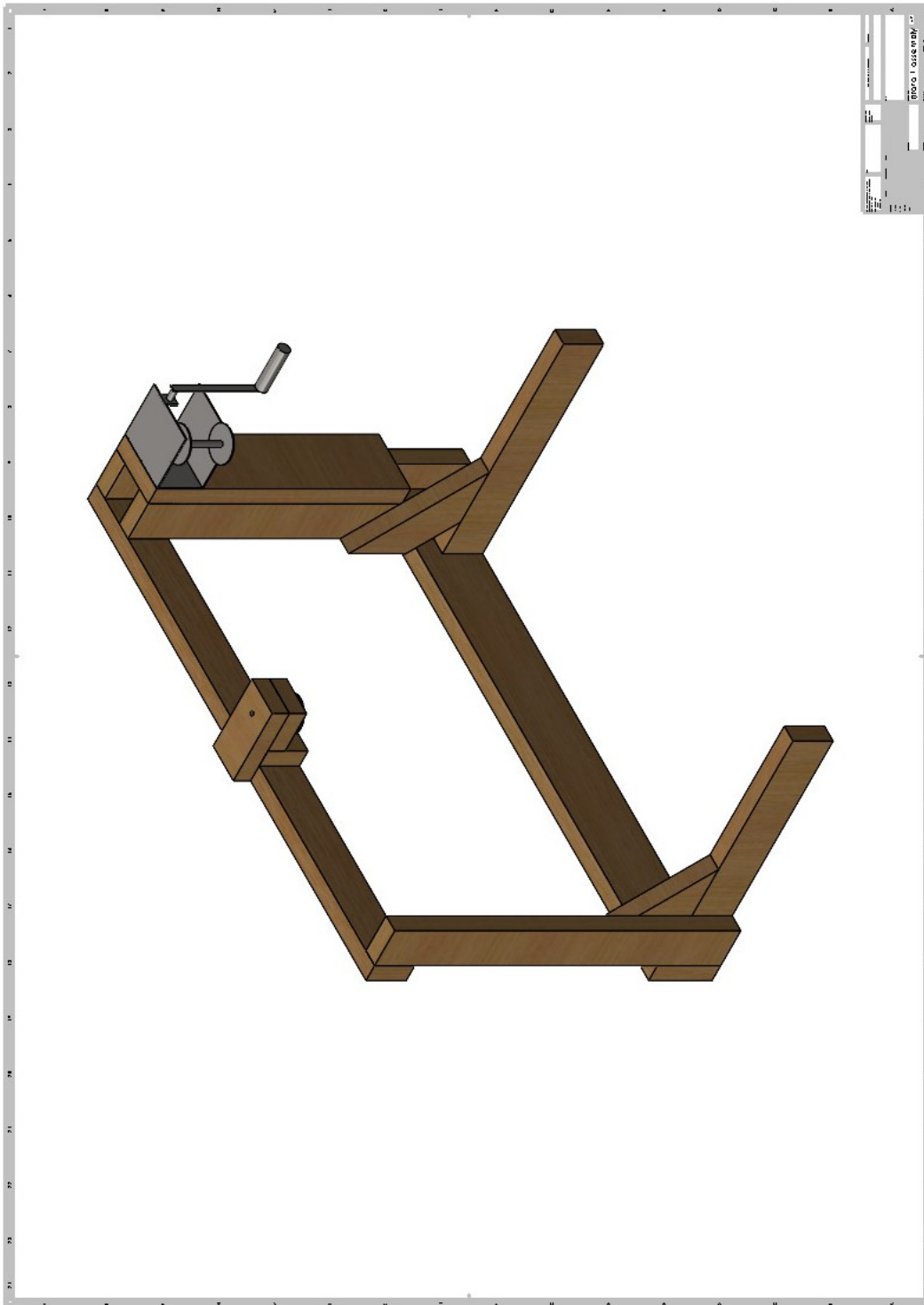

Figure 22: Large isometric view of assembly at a different angle



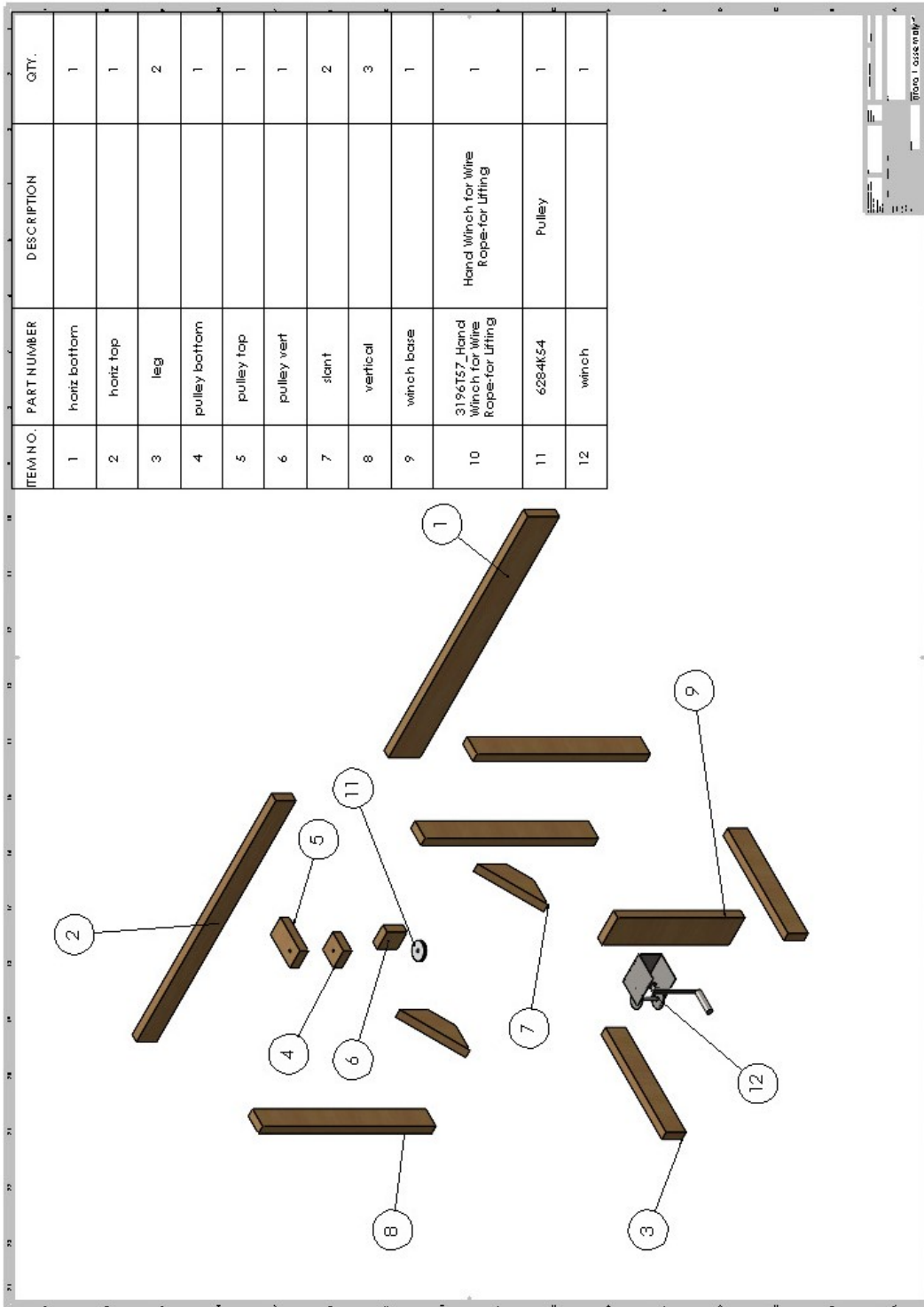

Figure 23: Exploded view with callout to BOM

## 5.2 Proofs-of-Concept

During the proof-of-concept process, we decided to build a frame system for the winch instead of only building a winch itself. This decision occurred due to more interviews with the customer in which they stated that they do not want to alter the surrounding lab environment, and have it stand as its own system. A standalone winch would not be able to pull the heavy tank unless it is anchored to a wall or part of the lab. Building a sturdy and reliable winch would have taken too much time, so we will purchase one instead, as well as metal beams for the frame.

## 5.3 Design Changes

We stuck with our selected concept from section 4, however as previously stated in section 5.2, we needed to design a frame to mount the winch to because we were unable to mount the winch to the wall. This frame will also contain a pulley system that will direct the reel of the winch to the center to be in line with the tank. We mounted the winch on the right side of our framing so that it won't interfere with the tank. The reel of the winch goes around a pulley located in the middle of the framing. This pulley is hanging off the top of our frame connected by a screw and nut. This design allows the user to be out of the way from the tank while reeling it up the scale. Our Initial prototype also contained a winch using a worm gear which had a 40:1 gear ratio, however it was very slow to reel in the tank. Our final design will contain a regular-gear-to-gear winch. The handle will be oriented perpendicular to the worm gear winch handle. To account for this, we will mount the winch to the inside framing of the vertical post, as opposed to the front of it.

# 6 Design Refinement

## 6.1 Model-Based Design Decisions

The first component of our prototype that took into consideration one of our engineering models was the winch that we used. We needed a winch that would be able to crank the cart up the ramp without breaking. Looking at Figure 19, we see an incline plane model of the cart on the ramp. The maximum assumed weight of the full cart was 1200 lbs and the angle of the ramp was assumed to be 15 degrees. We wanted to be generous in our assumptions so that we could choose a winch that had a capacity well over any force it would experience. In calculating the tensile force that the winch would experience, we simply did a force balance in the x-direction, as specified in the figure. Solving for  $F_T$  gave us  $W\sin\theta$ . Plugging in 1200 lbs for the weight and 15 degrees for  $\theta$ , we obtained an  $F_T$  value of 310.58 lbs. The winch we used in our prototype has a capacity of 2000 pounds which is well over what it will experience.

The second component of our prototype that considered one of our engineering models was the pulley system. Looking at the CAD models in Figures 21 and 22, you can see our winch is off-centered. The user needs to be well out of the way from the heavy tank when operating our device, so to obtain this objective we used a pulley. This pulley is located in the middle of our prototype and will translate the direction of motion from the off-centered winch to the tank located in the middle of our device. As stated in the paragraph below figure 20, we needed to know the force that the pulley will experience. This force was calculated in the previous paragraph to be 310.58 lbs. We chose a pulley with a radius of about 1.75" in order to smoothly translate the motion of the winch. We mounted the pulley by drilling a hole through the overhanging part in the middle and

adding a nut to the bottom of a metal screw which would sit in the hole we drilled, and hold up the pulley, while allowing it to rotate freely about its diameter.

## 6.2 Design for Safety

Below are some safety risks that must be considered when operating the device.

### 6.2.1 Risk #1: Winch Rope Snapping

**Description:** If the device is loaded past its specified load capacity, there is a risk of the rope snapping. The load capacity of the winch is 2000lbs. Do not exceed or come close to this capacity. It is also important to note that the environmental temperature could lower the capacity of the winch. In colder temperatures the rope may not be able to support its rated capacity so stay well under the 2000 lb limit.

**Severity:** Catastrophic: The rope snapping brings forth many risks. The high speed of the rope when snapped could result in severe injury of the user and maybe even death. The rope snapping would also make the tank roll down the ramp very fast and could lead to serious injury.

**Probability:** Unlikely: As long as the tension in the rope is well under the 2000 lb capacity, this risk should not occur.

**Mitigating Steps:** To ensure this risk does not happen, do not attempt to lift anything up the ramp that would be past the limited capacity of the winch. Also take into consideration if the temperature is very low and if you use the device on a very steep ramp, as these will make the load closer to the capacity.

### 6.2.2 Risk #2: Rope Detaching From Pulley

**Description:** This risk can occur if the user is not careful when using the device. If the user tries cranking the winch too fast, or shakes the device while using it, the rope could become derailed from the notches in the pulley. If the pulley gets wet there is a higher chance of this happening, as the friction keeping the rope inside the walls of the pulley will be reduced.

**Severity:** Critical: The rope detaching from the pulley will result in the tank quickly rolling down the ramp. This could result in the user being struck by the tank, their toes being rolled over, and much more.

**Probability:** Seldom: This event should not occur as long as the user is careful when operating the device and doesn't make any quick jerks or shakes that could allow the rope to detach.

**Mitigating Steps:** To reduce the probability of this risk, do not operate the device in wet conditions. Also keep the device sturdy and do not shake it when operating.

### 6.2.3 Risk #3: Pulley Support Breaking

**Description:** This risk involves the screw holding the pulley in place breaking or detaching from the device. This could occur if there is too much force on the pulley. This risk could also occur if there is a sudden force change (acceleration) on the pulley.

**Severity:** Critical: If the pulley support breaks, the tank will no longer be held up by the winch and it will roll down the ramp and could possibly strike the user or roll over their toes. It could also hit whatever is at the bottom of the ramp.

**Probability:** Unlikely: This risk should not happen, as the mount holding the pulley in place is secure.

**Mitigating Steps:** To reduce the probability of this occurring, the user should turn the winch at a constant speed, and not jerk it, creating high accelerations in the rope. As long as the user is careful and maintains a constant crank speed, this risk can be avoided.

#### 6.2.4 Risk #4: Tank Strap Breaking/Detaching

**Description:** This risk entails the strap that is wrapped around the Argon tank becoming disconnected or breaking. This could occur if the strap isn't secure or if the connection to the winch hook isn't secure.

**Severity:** Critical: This event would be critical as it would not only result in the tank quickly rolling down the ramp, but the strap could also fly off at high speeds, possibly blinding or harming the user. **Probability:** Occasional: This risk is likely to happen if the user isn't careful when securing the strap to the winch and making sure it is wrapped around the tank at a proper angle (level with the pulley).

**Mitigating Steps:** To prevent this from occurring the user must always ensure a secure connection of the strap and the winch and also make sure that the angle of the strap is level with the pulley so that the force is one-directional.

#### 6.2.5 Risk #5: System Dislocation from Mounted Position

**Description:** This risk involves the device dismounting from its mounted position. If the user does not ensure the proper angle between the pulley and the tank, the device could tip over.

**Severity:** Critical: If this risk were to occur, the entirety of the device could be flung in the user's direction, or at other people. It could also break the whole device.

**Probability:** Seldom: This event should not occur, however if the user isn't cautious when connecting the tank to the device, it could tip over.

**Mitigating Steps:** To prevent this risk from happening, the user must ensure that the hook connecting the winch to the strap is level with the pulley, to reduce an upward force.

		Probability that something will go wrong				
Category		Frequent Likely to occur immediately or in a short period of time; expected to occur frequently	Likely Quite likely to occur in time	Occasional May occur in time	Seldom Not likely to occur but possible	Unlikely Unlikely to occur
Severity of risk	Catastrophic					Winch Rope Snapping
	Critical		Tank Strap Breaking/Detachir		Rope Detaching From Pulley System Disslocation From Mounted Position	Pulley Support Breaking
	Marginal					
	Negligible hazard presents a minimal threat to safety, health, and well-being of participants; trivial					

Figure 24: Risk Heat Map

Looking at the Heat Map, the highest priority is making sure the tank strap doesn't break or become detached. This is the highest, as it is critical, yet could be an occasional occurrence. There is a tie for second and third highest priority with the rope detaching from the pulley and system dislocating from its mounted position. Both of these risks fall in the same square on our Heat Map as they both have a seldom probability and are critical severities. The next highest risk is also yellow on the Heat Map and involves the winch rope snapping. This event would be catastrophic, as it could severely harm the user or anyone around the device. However, the likelihood of this happening is unlikely as long as the user operates the winch well under its capacity. The final and least prioritized risk is the pulley support breaking. This event is unlikely yet critical, which is why it ranks in the green section of the Heat Map.

### 6.3 Design for Manufacturing



Figure 25: Current Prototype Device

Count of the number of parts in the design, excluding threaded fasteners: 16. Count of the threaded fasteners in the design: about 45.

Theoretical Necessary Components: winch and rope, pulley, and tank strap. The winch and rope are necessary as they are the mechanical advantage for the system. The rope is wound on a rod containing the gear which can be removed to change the rope or gear. The entire winch can detach from the frame as well for a new winch. The pulley is required to translate the pulling direction of the winch so that the frame can sit closer to the wall. It is separate to allow it to rotate freely and if it ever needs to be replaced or adjusted. The tank strap is separate so that its position can be adjusted on the tank and to be out of the way when not in use. It also is necessary to connect the rope hook to the tank.

Hypothetically, the design of our winch and frame could be altered to be closer to number of TNCs. In order to do this, though, many of the wood pieces would have to be merged and cut as one larger piece instead of using 2x4s and 2x6s. However, some of these would be easily possible to manufacture as larger pieces, such as the pieces that hold and support the pulley could be one piece cut from a 4x4 or a 6x6. But, this would most likely increase manufacturing costs as thicker pieces of wood are typically more expensive and more precise cutting tools would be necessary to achieve this. There also might be ways to eliminate components through optimization methods and redesigning certain components to do the eliminated components' job.

## 6.4 Design for Usability

**Vision Impairment:** Visual impairment does not inhibit the use of our device to a severe degree, it is preferred but not necessary. Trouble could arise if the operator is attempting to read instructions written on the gas tank or winch for cases of presbyopia, however operating the winch does not require perfectly clear vision.

**Hearing Impairment:** Similar to visual impairment, hearing impairment will only minimally affect the usability of our device. Operating the winch and moving the tank do not require perfect hearing, however audio cues may help quickly recognize cases where the tank slips on the ramp or the winch fails.

**Physical Impairment:** Physical impairments would occur if the operator is unable to supply enough force to operate the winch. To overcome this issue, the manual winch could be switched out for an electric model. This would require a simple button press rather than cranking the lever arm.

**Control Impairment:** Control impairments from medication side effects, fatigue, or intoxication could severely impact the operation of our device. Operators must maintain control of the system composed of the winch device and heavy tank. Lack of focus or physical ability can lead to severe damage to the laboratory or persons nearby.

## 6.5 Design Considerations

Table 3: Factors considered for design solution

Design Factor	Applicable	Not Applicable
Public Health		X
Safety	X	
Welfare	X	
Global		X
Cultural		X
Societal		X
Environmental		X
Economic	X	

Table 4: Contexts considered for ethical judgments

<b>Situation</b>	<b>Applicable</b>	<b>Not Applicable</b>
Global context		X
Economic context	X	
Environmental context		X
Societal context		X



# 7 Final Prototype

## 7.1 Overview

Our final prototype consisted of aluminum extrusion bars instead of wood for stronger support and internal structure. We replaced the hand crank winch with an electric winch that uses a remote to operate to make the work from the user lighter as well as decrease the time required to perform the task. The hook connects to a tie down strap that gets wrapped around the tank for an easy attachment.

## 7.2 Documentation

Below is a visual of our final prototype with winch being in the middle instead of off to the side since it no longer requires a person to crank it and a pulley to translate the motion. The metal framework parts were ordered from McMaster Carr and the winch was bought from Harbor Freight.



Figure 26: Final Prototype Device

## Bibliography

- [1] Matweb.com. *AISI 1045 Steel, Cold Drawn*. 2019. URL: [http://www.matweb.com/search/datasheet\\_print.aspx?matguid=193434cf42e343fab880e1dabdb143ba](http://www.matweb.com/search/datasheet_print.aspx?matguid=193434cf42e343fab880e1dabdb143ba).