

Justification of the width of the tooth spacing and the distance between the rows of teeth of the ripper for the harrower

U J Bababekov^{1,*}, E S Kurbanov¹, A Tukhtakuziev², P D Davlatov¹, E E Kurbanov¹, and R H Xudayberdiyev¹

¹Gulistan State University, Syrdarya, Uzbekistan

²Research Institute of Agricultural Mechanization of the Republic of Uzbekistan, Uzbekistan

Abstract. The article substantiates the degree of immersion of working bodies in the soil and soil deformation on the basis of scientific and experimental studies of the harrowing unit used. The parameters of the harrow teeth, the qualitative performance of the technological process of the accepted parameters are also theoretically justified.

1 Introduction

In our republic, soil harrowing is carried out in two tracks per one pass of the unit with BZSS-1.0, BZTS-1.0 or BZTH-1.0 harrows arranged in two rows. At the same time, heavy harrows BZTS-1.0 and BZTH-1.0 are used in fields that have received multiple washings, and in other cases – medium harrows BZSS-1,0 [1-8].

The use of existing heavy, wide-reach harrowing units has a number of disadvantages, i.e., when cultivating the soil, the ripper teeth are clogged with soil and plant residues, which leads to a deterioration in the quality of processing and violation of agro-technical requirements.

2 Materials and methods

The width of the ripper teeth spacing is set in such a way as to ensure continuous loosening of the treated soil layer. To solve this problem, consider the process of destruction (loosening) of the soil by a vertically mounted wedge with a sharpened angle 2β and a straight lower edge (i.e., the lower end of the tooth does not have a bevel) when moving it at a given h depth at a V_n speed (figure 1).

According to the data of Academician G.M. Rudakov, it is known [1] that the destruction of the soil under the influence of a vertically installed wedge occurs by chipping. As the wedge progresses, the soil is first crushed in the horizontal direction, its particles are pressed into the adjacent medium. Then, when the deformation of the crumple reaches the limit value, the soil is destroyed with the formation of chipping surfaces. For

* Corresponding author: umidbekbababekov@gmail.com

example, when the wedge moves from position I to position II, the wedge cheek removes the OO_1B_1 section, as a result of which horizontal crumpling stresses arise in the soil, leading to the appearance of two shear planes: O_1AO_1' located at an angle ψ_1 to the direction of movement, and located at an angle O_1AO_1' to the working face ψ_2 of the wedge. As a result, a block in the form of a triangular prism is separated from the soil. With further movement of the wedge, the shifted volume of soil begins to slide up along the wedge surface and shear planes. At the same time, the crumpling of the soil occurs, ending with the chipping of the next part of it.

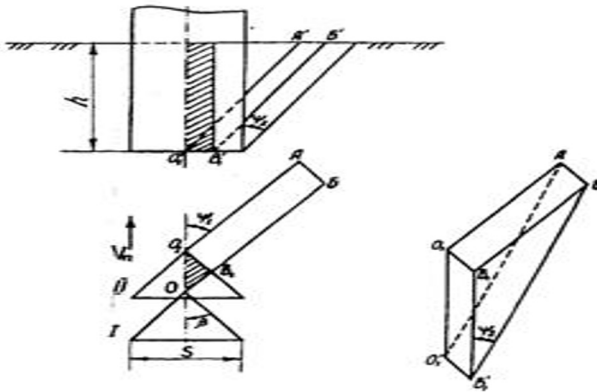

Figure 1. Deformation of soil in vertical wedge.

Using Mohr's strength theory, V.P. Goryachkin [2] determined

$$\psi_1 = \frac{\pi}{2} - \frac{\beta + \varphi + \varphi'}{2}, \tag{1}$$

Where φ, φ' – angles of internal and external friction of the soil.

According to G.M.Rudakov [1]:

$$\psi_2 = 42 - 45^\circ \tag{2}$$

As noted, the teeth of the ripper of the harrowing unit are arranged in two rows. During the operation of the unit, the teeth of the first row act on the soil that has not yet been deformed, the second row - on the soil partially deformed by the teeth of the first row.

3 Results and Discussion

As our experimental studies have shown, depending on the width of the interline, the nature of soil deformation by the teeth of the second row changes: up to a certain value of the interline of the teeth, the soil shift in the transverse-vertical plane from the impact of the teeth of the second row occurs not along the inclined plane N-N, but along the horizontal plane M-M (figure 2).

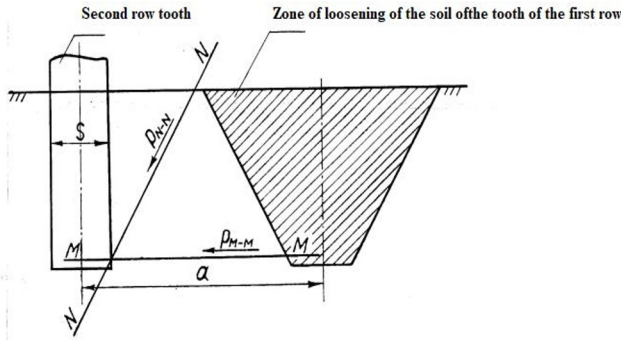

Figure 2. Scheme to substantiation of the width of the tooth spacing.

When the width of the tooth spacing reaches a certain value, the soil begins to shift along the inclined plane N-N, as described above.

Obviously, in order to achieve continuous loosening of the treated soil layer, the width of the tooth spacing should be such that the soil is shifted along the horizontal plane M-M. Obviously, a shift of the soil along the M-M plane is possible if:

$$P_{M-M} < P_{N-N} \quad (3)$$

Where: P_{M-M}, P_{N-N} – the forces of soil resistance to chipping along the M-M and N-N planes.

It is known that [3;9-12]:

$$P_{M-M} = \tau_{M-M} \cdot S_{M-M} \quad (4)$$

And:

$$P_{N-N} = \tau_{N-N} \cdot S_{N-N} \quad (5)$$

Where: τ_{M-M}, τ_{N-N} – specific resistance of the soil to shear in planes M-M and N-N; S_{M-M}, S_{N-N} – the area of soil cleavage along the M-M and N-N planes.

By analyzing pic. 3 and 4, we find that:

$$S_{N-N} = O_1 B_1 \cdot h / \cos \psi_2 \quad (6)$$

And:

$$S_{M-M} = O_1 B_1 \left(a - \frac{S}{2} \right) \cos \beta \quad (7)$$

Where: a - the width of the tooth spacing; S - is the thickness of the tooth.

Substituting values S_{M-M}, S_{N-N} – in (4) and (5), then values P_{M-M} and P_{N-N} in (3) then excepting $\tau_{M-M} = \tau_{N-N}$ we note:

$$\left(a - S/2 \right) \cos \beta < h / \cos \psi_2 \quad (8)$$

Where:

$$a \leq \left(h / \cos \psi_2 \cdot \cos \beta \right) + S/2 \quad (9)$$

It follows from (9) that the width of the tooth spacing, at which continuous loosening of the treated soil layer is ensured, depends on the depth of processing and the physic-mechanical properties of the soil, the thickness and the angle of sharpening of the teeth.[12-18]

By inserting in (9) $h = 5 \text{ sm}$, $\psi_2 = 42^\circ$, $\beta = 45^\circ$ u $S = 2.2 \text{ sm}$ we find $a \leq 10.7 \text{ sm}$

Thus, in order to ensure continuous loosening of the treated soil layer, the width of the gap between the teeth of the ripper should not exceed 10.7 sm.

The distance L between the rows of teeth is chosen from the condition of preventing clogging of the gaps between them by plant residues and soil. When clogging, the technological process of the ripper is disrupted, its traction resistance increases.

In order to avoid clogging the gap between the front and rear rows of teeth with soil, the distance L should be made larger than the zone of propagation of l - deformation of the soil along the course of the teeth (figure 3), i.e.

$$L > l \tag{10}$$

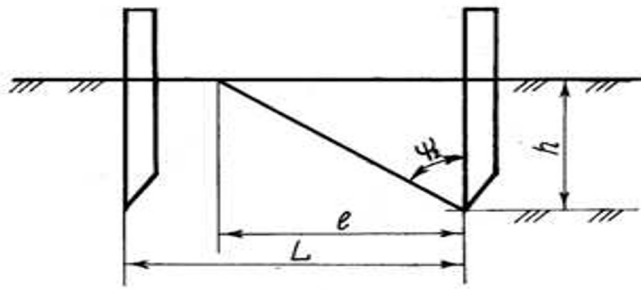

Figure 3. Diagram for determining the distance between rows of ripper teeth.

According to figure 3, the greatest value of the zone of propagation of soil deformation along the course of the teeth is equal to:

$$l = h_{\max} \cdot \text{tg} \psi_2 \cdot \cos \psi_1 \tag{11}$$

Where h_{\max} - the greatest depth of immersion of the teeth in the soil;

Taking into account (11) and the width of the tooth spacing, equation (10) will take the form:

$$L > h_{\max} \cdot \text{tg} \psi_2 \cdot \cos \psi_1 + S \text{ctg} \beta \tag{12}$$

In expression (12), we introduce a coefficient K that takes into account the unloading of the soil in front of the ripper teeth [19-20], i.e.

$$L > \kappa h_{\max} \cdot \text{tg} \psi_2 \cdot \cos \psi_1 + S \text{ctg} \beta \tag{13}$$

The value of the coefficient K depends on the condition of the soil and the parameters of the working body.

By accepting $h_{\max} = 10 \text{ sm}$ [13],
 $\psi_2 = 45^\circ$ [14], $\psi_1 = 20^\circ$ *u* $K = 1.8$ [14–18], we receive
 $L > 1.8 \cdot 10 \cdot 1.0 \cdot 0.866 + 2.2 \cdot 1.0 = 19.1 \text{ sm}$

Therefore, in order to avoid clogging the ripper with soil, the distance between the rows of teeth should be at least 19.1 sm.

4 Conclusion

Analytical studies have shown that the best quality of tillage is provided by the vertical installation of the ripper teeth.

It was revealed that the spacing of the ripper teeth depends on the depth of tillage, physical and mechanical properties, thickness and angle of sharpening of the teeth. To ensure continuous loosening of the treated soil layer, the spacing of the teeth should not exceed 10.7 sm.

To avoid clogging the gap between the transverse rows of ripper teeth with soil and plant residues, it is necessary to set the distance between the rows of teeth at least 19.1 sm.

References

1. Rudakov G M 1974 Technological bases of mechanization of cotton sowing (Tashkent: Fan. UzSSR) 245
2. Goryachkin V P 1968 Collected works in 3 volumes (Moscow: Kolos) **1-2**
3. Ponomarev E I 1988 Dependence of soil unloading on the parameters of the working organ - comb-forming. Improvement of machines and mechanisms for cotton growing (Tashkent: CAMASR SAO VASHNIL) 72-77
4. Tukhtakuziev A 1979 Investigation and substantiation of the parameters of the tooth harrow for operation at increased speeds in the cotton-growing zone. Diss.Candidate of Technical Sciences, Tashkent 144
5. Baymetov R I, Mirakhmatov M and Tukhtakuziev A 1985 Tillage at high speeds in the cotton growing zone (Tashkent: Fan. UzSSR) 48
6. Sineokov G N and Panov I M 1977 Theory and calculation of tillage machines. Mechanical engineering 328
7. Pigulevsky M H 1936 Fundamentals and methods of studying soil deformations. TKPSHM (Moscow: Selkhozgiz) **2** 421-527
8. Begimov H 1968 Agrotechnical assessment of techniques and tools for pre-sowing treatment of saline soils of the Khorezm region. Dis.cand.agricultural sciences, Urgench 129
9. Nikolaev V A, Kubaev E I and Kryaklina I V 2007 Calculation and graphic work on agricultural machines (Yaroslavl: FGOUVPOYAGSKHA) 85
10. Nikolaev V A 2011 Determination of the kinematic parameters of the impact device of the combined soil tillage tool. Technique in agriculture **1** 6-8
11. Nikolaev V A, Yurkov M M and Gorshkov Yu G Evaluation of the work of friction forces during plowing. Mechanization and electrification of agriculture **1** 2
12. Nikoforov P E and Surin V V 1968 Dependence of the stability and quality of the tooth harrow on the parameters of the working organs and the speed of movement. Scientific

- foundations of increasing the working speeds of machine-tractor units (Moscow: Kolos) 324-334
13. Safarov R B 1981 Investigation of optimal parameters, operating modes and forecasting conditions of efficiently-functioning aggregates for pre-sowing tillage in the cotton-growing zone. Diss. Candidate of Technical Sciences, Yangiyu 208
 14. Baimetov R I, Tukhtakuziev A and Kurbanov E S 1989 Mounted harrow hitch. Cotton **2** 32-32
 15. Tukhtakuziev A, Mansurov M and Rasuljonov A 2019 Scientific and technical solutions to ensure the stability of the working depth of tillage machines attached to the frame of the working bodies. Monograph Tashkent, Muxr PRESS 70
 16. Tukhtakuziev A, Mansurov M, Rasuljonov A and Karimova D 2020 Scientific bases of ensuring the stability of the working depth of tillage machines, Monograph (Tashkent: Publishing House TURON-IQBOL) 168
 17. State acceptance tests of the prototype of the ABN-8.5 mounted harrowing unit. Protocol No. 26-17-89(8075200) SredasMIS 48
 18. Shoumarova M and Abdillaev T 2009 Agricultural machinery (Tashkent: publishing house Textbook "TEACHER") 504
 19. Khachatryan H A 1963 The work of tillage tools in mountainous terrain (Yerevan:Armsizdat) 259
 20. Tsimeran M Z 1978 Working bodies of tillage machines (Moscow: Mechanical engineering) 296