

This is the peer reviewed version of the following article:

High-diversity larger foraminiferal assemblages calibrated with calcareous nannoplankton biozones in the aftermath of EECO (Collio, Friuli-Venezia Giulia, northeastern Italy) / Benedetti, A.; Papazzoni, C. A.; Bosellini, F.; Giusberti, L.; Fornaciari, E.. - In: PALAEO WORLD. - ISSN 1871-174X. - (2023), pp. 1-12. [10.1016/j.palwor.2023.01.013]

Terms of use:

The terms and conditions for the reuse of this version of the manuscript are specified in the publishing policy. For all terms of use and more information see the publisher's website.

05/02/2024 20:30

(Article begins on next page)



High-diversity larger foraminiferal assemblages calibrated with calcareous nannoplankton biozones in the aftermath of EECO (Collio, Friuli-Venezia Giulia, northeastern Italy)

Andrea Benedetti^a, Cesare Andrea Papazzoni^{a,*}, Francesca Bosellini^a, Luca Giusberti^b
Eliana Fornaciari^b

^a *Dipartimento di Scienze Chimiche e Geologiche, Università di Modena e Reggio Emilia, Via G. Campi 103, 41125 Modena, Italy*

^b *Dipartimento di Geoscienze, Università di Padova, Via G. Gradenigo 6, 35131 Padova, Italy*

Received 1 September 2022; received in revised form 4 January 2023; accepted 17 January 2023

Abstract

The Eocene of Collio (easternmost Friuli-Venezia Giulia, northeastern Italy) contains rich larger foraminiferal assemblages mainly dominated by nummulitids of genera *Nummulites* and *Assilina*. Herein, we document, by typological and biometric approaches, upper Ypresian to lower Lutetian taxa, dated by an integrated biostratigraphy combining the Shallow Benthic Zones (SBZ) with the nannofossil biozones. A total of seven species of *Alveolina*, 12 species of *Assilina* and 33 of *Nummulites* are described (in [Appendix A](#)), some of them left in open nomenclature. The larger foraminiferal assemblages indicate that all the collected samples are assignable to SBZ12 and SBZ13 and their high diversity suggests high resilience of these shallow-water taxa after the Early Eocene Climate Optimum warming event. The occurrence of the calcareous nannofossil *Blackites inflatus* together with *Alveolina violae* *Nummulites friulanus*, *N. campesinus*, *N. quasilaevigatus*, *Assilina maior maior* and *A. cuwillieri*, typical SBZ12 markers, suggests that SBZ12 extends at least to the basal Lutetian, thus the SBZ12/13 boundary occurs in the lowermost Lutetian instead of at the Ypresian/Lutetian transition.

© 2023 Elsevier B.V. and Nanjing Institute of Geology and Palaeontology, CAS. All rights reserved.

Keywords: Alveolinidae; Nummulitidae; Shallow Benthic Zones; biostratigraphy; Ypresian; Lutetian

1. Introduction

Larger foraminifera (LF) are highly sensitive to environmental changes because they are mostly confined in shallow water settings that are affected by sea-water level oscillations. Climate and temperature play an important role in the distribution of LF especially because they host symbiotic algae within their test as suggested by extant representative of this informal group of protists (e.g.,

[Hohenegger, 2011](#)). The Paleogene was a period of intense climate changes, and in particular the early Eocene recorded the warmest temperatures of the whole Cenozoic (e.g., [Zachos et al., 2001](#); [Luciani et al., 2016](#)). Whilst the Paleocene was characterized by a rapid evolution of rotalids among shallow water benthic fauna ([Hottinger, 2014](#); [Benedetti and Papazzoni, 2022](#)), the earliest Eocene recorded an outbreak of alveolinids and nummulitids with the radiation of parallel lineages within the genera *Alveolina* and *Nummulites* (e.g., [Drobne, 1977](#); [Schaub, 1981](#); [Drobne et al., 2011](#)). After the Paleocene Eocene Thermal Maximum (PETM), and during the whole Eocene, the diversification of nummulitids, alveolinids and orthophragminids has been linked to global warming events ([Whidden](#)

* Corresponding author.

E-mail addresses: andrea.benedetti@unimore.it (A. Benedetti), papazzoni@unimore.it (C.A. Papazzoni), francesca.bosellini@unimore.it (F. Bosellini), luca.giusberti@unipd.it (L. Giusberti), eliana.fornaciari@unipd.it (E. Fornaciari).

and Jones, 2012) such as the Early Eocene Climatic Optimum (EECO) and the Middle Eocene Climatic Optimum (MECO). The latter intervals recorded high temperature, oligotrophic conditions in shallow water environments, and sea level rise, thus providing favourable conditions for the increasing abundance and diversification of LF (e.g., Whidden and Jones, 2012; Benedetti and Papazzoni, 2022).

The aim of this work is to investigate the diversity of post-EECO larger foraminiferal assemblages from eastern Friuli-Venezia Giulia region (northeastern Italy), and to understand their possible resilience after the longest and most intense warming event recorded in the whole Cenozoic. We also provide new integrated stratigraphic data from nannofossil assemblages from the investigated samples to check the position of the Ypresian/Lutetian boundary in terms of Shallow Benthic Zones (SBZ: Serra-Kiel et al., 1998).

2. Geological setting

The southeastern Friuli (northeastern Italy), better known as the Collio (Gorizia Province), is characterized by low hilly reliefs belonging to the southern Julian Prealps. The latter are the southern geographic edge of the Julian Alps, bordered at east by the Isonzo River, at west by the Tagliamento River and at south by the Cerkno line (e.g., Castellarin and Vai, 1982). Here, the Cenozoic deposits are mostly represented by flysch-type sediments (e.g., Cucchi et al., 2009).

The rocks exposed in the Collio area are mostly tectonically disturbed by NW-SE trending thrusts, faults and folds resulting in intense deformation and repetition of fossiliferous beds (e.g., Tunis and Pirini Radrizzani, 1987; Venturini and Tunis, 1989, 1992a).

The Eocene of the Collio is well-known since the seminal work by Dainelli (1915) for its abundance of marine fossils. Alveolinids (Checchia-Rispoli, 1905; Hottinger, 1960), nummulitids (Schaub, 1962, 1981), echinoids (Maddaleni and Tunis, 1993) and corals (Dainelli, 1915; Maddaleni, 1997) are well documented from the herein investigated area. In particular, the outcrops near Russiz yielded high-diversified coral faunas (Bosellini et al., 2022).

From the late Cretaceous to the Eocene, the eastern Friuli Julian Basin was characterized by a mixed siliciclastic-carbonate sedimentation; in particular, the lower Paleogene sedimentary succession consists of two different units known as “Flysch di Masarolis” (middle to late Paleocene) and “Flysch del Grivò” (late Paleocene to early Eocene), which contain megabreccias and carbonate megabeds derived from the neighbouring Friuli Platform (Tunis and Venturini, 1992). These units are overlain by the Flysch di Cormons deposits, in which megabeds are usually very rare.

Martinis (1962) defined the Flysch di Cormons Formation with three principal lithofacies, i.e., “facies marnosa, marnoso-arenacea and conglomeratica” that altogether

reach a maximum thickness of 330 m. Similarly, in the Slovenian Collio, Faninger et al. (1962), Pavlovec (1966) and Cimerman et al. (1974) suggested the formational term Medana Beds of Cuisian (= upper Ypresian) age, considered as a synonym of Flysch di Cormons by Tunis and Pirini Radrizzani (1987). The Flysch di Cormons is routinely assigned to the lower to middle Eocene (upper Ypresian to lower Lutetian) and it characterizes most of the Collio of Gorizia (Tunis and Pirini Radrizzani, 1987). Along the Ypresian–Lutetian transition, a rapid drowning led to the erosion of ramp carbonate deposits covered by emipelagites on which the Flysch di Cormons lies in onlap (Zanferrari et al., 2008).

The siliciclastic sediments with rare, amalgamated sandstones and conglomerates and thick calciclastic beds of Flysch di Cormons are commonly interpreted as derived from the accumulation of deltaic deposits from the margins of the Friuli carbonate platform (e.g., Venturini and Tunis, 1992b; Zanferrari et al., 2008). The microconglomerates cropping out at different levels yielded several reworked clasts originated from the Julian Prealps such as fragments of dolomites, vulcanites and terrigenous material, mixed with larger foraminiferal tests, mollusc shells and radiolarites, which are referred to the sedimentary successions spanning from the Triassic dolomites to the Cretaceous–Paleogene flysch (Venturini and Tunis, 1992b).

The uppermost Flysch di Cormons has been interpreted as deposited in a quite shallow marine environment influenced by fluvial-dominated delta system (Tunis and Pirini Radrizzani, 1987; Venturini and Tunis, 1992a, 1992b) and its age is constrained to the late Cuisian–earliest Lutetian (Castellarin and Zucchi, 1963; Piccoli and Proto Decima, 1969). The progradation of a prodelta in the early Lutetian is possibly linked to a tectonic uplift (Venturini and Tunis, 1992a).

The fossiliferous levels of Russiz yielding corals are at the base of prodelta sediments, possibly deposited at 30–100 m water depth and constituted by levels with scattered pebbles, with interbedded arenaceous levels, nummulitic breccias and microconglomerates containing also siliciclastic material of fluvial origin. Venturini and Tunis (1992b) suggest possible occurrence of coral patch reefs in the deltaic setting of the lower Lutetian during a transgressive phase, with the coastline possibly located in the Slovenian Collio. Although most of the corals near Russiz were routinely considered as Lutetian in age, middle Eocene nummulitids were never reported from herein investigated localities.

3. Previous works on larger foraminifera in the study area

The flysch successions of the easternmost Friuli and western Slovenia yielded several new taxa since the beginning of 20th century. Checchia-Rispoli (1905) described the new species *Alveolina violae* from the Eocene of Buttrio and Rosazzo (marker of late Cuisian, SBZ12, according to Serra-Kiel et al., 1998); Hottinger (1960) dedicated to Dainelli an

alveolinid from the middle Cuisian of Buttrio characterized by 9–12 flosculinized whorls, i.e., *Alveolina dainellii*, and also found some other species such as *A. lehneri*, large-sized *A. canavarii* (left in open nomenclature as *A. aff. canavarii* by Drobne, 1977) and a large morphotype of *A. fornasinii*. De Zanche et al. (1967) described a rich *Nummulites* assemblage from the middle Cuisian of Ustje (Vipava Valley, Slovenia) consisting of ten species. A brief summary of the nummulites of the Dinaric area was published by Pavlovec (2012). Schaub (1962) erected *Nummulites friulanus* from the upper Cuisian of Rosazzo. Schaub (1981) reported several nummulitids from the eastern Friuli, most of them from the middle Cuisian *Alveolina dainellii* zone identified in the outcrop Casa Ottelio, near Buttrio, yielding several *Nummulites* and *Assilina* species such as *N. burdigalensis cantabricus*, *N. burdigalensis pergranulatus*, *N. kapelloi*, *N. cf. inkermanensis*, *N. cf. rotularius*, *N. aff. pomeli*, *N. cf. obsoletus*, *N. pavloveci*, *N. tauricus*, *N. pustulosus*, *N. increscens*, *N. cf. nemkovi*, *N. cf. subdistans*, *N. aff. planulatus*, *N. aff. formosus* and *A. aff. laxispira*. Schaub (1981) documented also nummulitids from the upper Cuisian sediments near Rosazzo such as *N. friulanus*, *N. campesinus*, *N. manfredi*, *N. quasilaevigatus*, *N. praelorioli*, *Assilina maior*, *A. maior punctulata* and *A. aff. cuvillieri*.

From the coeval deposits of the Medana beds in Slovenia, Pavlovec in Cimerman et al. (1974) reported a rich nummulitid assemblage composed of *Assilina reicheli*, *A. maior*, *A. cf. spira*, *A. medanica*, *A. sp.*, *Nummulites friulanus*, *N. campesinus*, *N. manfredi*, *N. quasilaevigatus*, *N. cf. obesus*, *N. cf. lehneri* and *N. cf. gallensis*.

4. Material and methods

4.1. The outcrops

A total of 14 samples of brown marls were collected from the Flysch di Cormons Formation in the eastern Collio. Seven samples came from poorly exposed outcrops near Russiz and another seven from different localities near Rosazzo and Noax (Fig. 1).

Sample collecting in continuous sedimentary succession is currently hampered by wide vegetated and cultivated area characterizing the whole Collio, without a continuous stratigraphic section. Because of the quality of the outcrops, an accurate description of facies is unfeasible.

Locally, coral-bearing blocks crop out among vineyards (Bosellini et al., 2022), and most of the investigated samples are composed of packed larger foraminiferal tests (mainly nummulitids) with subordinate solitary and colonial corals and scattered molluscs and bryozoans within a marly matrix. Two samples (RSZCOR, RSZVI) were collected from bioclastic and biodetritic limestone lenses sporadically occurring through the Flysch di Cormons Formation.

Our biostratigraphic and paleoenvironmental interpretation derives from punctual analysis of faunal content from each sample. An integrated analysis of the shallow

benthic biozones, mainly based on LF, with data from the associated calcareous nannofossil assemblages has been performed to make age determination for each sample.

4.2. Larger foraminifera

Biometric and morphometric analyses have been performed on larger foraminiferal tests belonging to nummulitids and *Alveolina*.

We did not count the relative abundances of different species, since most of them were recognized only in oriented sections, with similar outer characters.

The sediments were cleaned with hydrogen peroxide, dried and then split into different fractions. The specimens were picked from washed residues sieved at 250 μm and photographed under stereoscopic microscope; *Alveolina*, *Discocyclina* and smaller nummulitids were abraded up to the centred section passing through the embryo, whereas large nummulitid B-forms were split along the equatorial plane by using pliers. Each specimen was then photographed using a Nikon Coolpix 990 digital camera mounted on a stereoscopic microscope. Selected specimens were redrawn to show the inner structure.

The determination of *Nummulites* and *Assilina* is based on both surface ornamentation and inner characters. We focus on both microspheric (B) and megalospheric (A) forms associated in most samples. The external characters were investigated only typologically, whereas the internal characters were measured and counted on equatorial (nummulitids) or axial (*Alveolina*) oriented planes. A morphometric analysis is attempted for the megalospheric (A) forms mainly based on the parameters introduced by Drooger et al. (1971) and Less (1999), although the number of specimens per sample is not sufficient for statistical analysis of populations. Thus, a statistical analysis was performed after the typological approach. This study provides the first detailed morphometric investigation of upper Cuisian–lower Lutetian nummulitids.

Apart from the maximum measurable diameter and thickness, the following morphometric measures have been taken into account for megalospheric specimens of nummulitids, i.e., both *Assilina* and *Nummulites*:

P: the inner cross diameter of the proloculus, measured perpendicularly to the line that pass through the centre of the two embryonic chambers;

d2: the outer diameter of the first two whorls;

d3: the outer diameter of the first three whorls;

E: the number of chambers in the first two whorls as evidenced in Fig. 2; the two embryonic chambers are excluded from the count;

N: number of chambers in the third whorl;

K: index of spiral opening (after Less et al., 2008) = $100 \times (d3-d2)/(d3-P)$;

L: average length of chambers = $d2 \times \pi/N$;

F: average shape of chambers = $100 \times (d3-d2)/(d3-d2+2 \times d \times L)$.

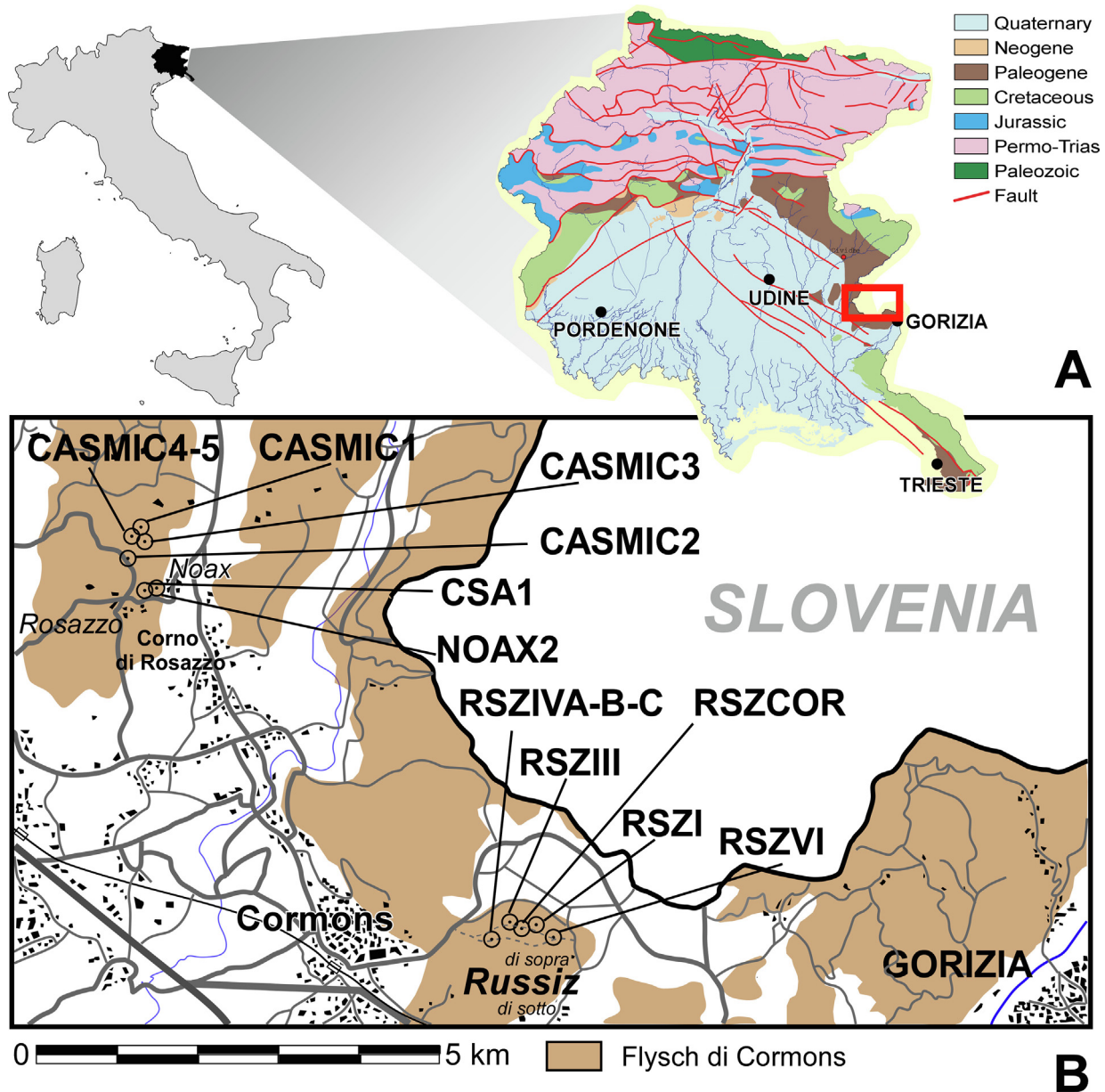

Fig. 1. Map of the Collio area, in the eastern Friuli-Venezia Giulia region (northeastern Italy, A), with location of the investigated samples (B).

For microspheric specimens, we obtained the spiral diagrams by measuring the radius per whorl. Future studies need to investigate the marginal spiral following the methodology in Hohenegger (2011) on a convenient number of specimens per sample.

For the single megalospheric specimen of *Discoeyclina* we measured the protoconch and deutoconch diameters, the number of periembryonic adauxiliary chamberlets in the first annulus, the number of annuli within 0.5 mm from the deutoconch, the height and width of a chamberlet in the first annulus and the height and width of chamberlet in the fifth annulus.

For the alveolinids we measured also the axial and equatorial diameter at 10th, 13th and 15th whorls and the relative elongation index.

The measurements were taken using Canvas 14TM. All the specimens are stored in the Dipartimento di Scienze Chimiche e Geologiche at the University of Modena and Reggio Emilia. The results of counts and measurements are given in Tables S2, S3.

4.3. Calcareous nannofossils

Ten samples (RSZI, RSZIII, RSZIVA, RSZIVB, RSZIVC, RSZVI, CASMIC1, CASMIC 2, CASMIC5, NOAX2) were prepared from unprocessed material as smear slides and examined using a light microscope at 1250 \times magnification. The presence/absence of index species was tabulated for calcareous nannofossil assemblages in a slide area of ~ 6 mm² (three vertical traverses;

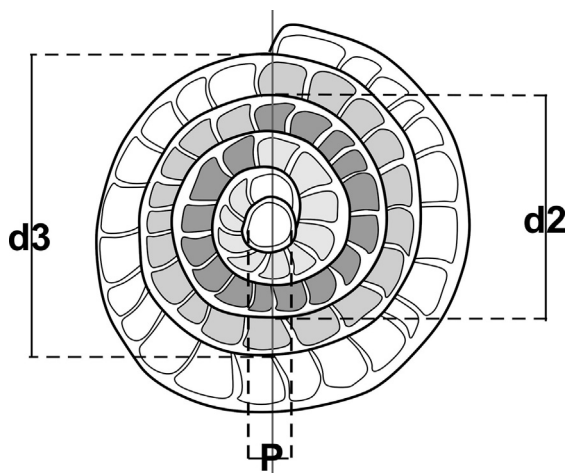

Fig. 2. Schematic drawing of a megalospheric specimen of *Nummulites* with the main biometric parameters utilized in this study. The light and dark grey shows chambers for each whorl. P: inner cross diameter of the proloculus; d2: outer diameter of the first two whorls; d3: outer diameter of the first three whorls.

Gardin and Monechi, 1998). When possible, the relative abundance of *Sphenolithus* species were calculated for at least 30–50 specimens of the genus (Rio et al., 1990). Taxonomic concepts follow those of Perch-Nielsen (1985) and Nannotax (Young et al., 2017). We adopted the low-middle latitude zonation of Agnini et al. (2014).

5. Results

5.1. Larger foraminifera

A selected fraction of washed residue revealed the dominance of nummulitids, both *Assilina* and *Nummulites* in all the samples (Figs. 3, 4), whereas *Alveolina* is rare or absent in most samples. A total of 7 species of *Alveolina*, 12 species of *Assilina* and 33 of *Nummulites* were recognized (Table S1). Only one megalospheric recognizable specimen of *Discoyclina* was recovered from the samples. Species identification was made on the base of comparison with type material (e.g., Drobne, 1977; Schaub, 1981), assisted by biometric measurements (see Appendix A and Table S3 for an extensive taxonomic study). Spiral diagrams for selected lineages are provided (Figs. 5, 6). Possible new species, here left in open nomenclature, are present, with the tighter spirals of B-forms as the possible ancestor form, such as *N. cf. friulanus* (Fig. 5A), *N. cf. tauricus* (Fig. 5B), *N. cf. polygyratus* (Fig. 5D), *Assilina* aff. *temuimarginata* (Fig. 6B), or looser spirals *A. cf. spira abrardi* (Fig. 6A), *A. cf. cuvillieri* (Fig. 6B).

According to the LF assemblages (see Appendix A and Table S1), samples RSZCOR, RSZI, RSZIII, RSZIVA +50, RSZIVB, CASMIC2, CASMIC3, CASMIC4, CASMIC5, CSA1 and NOAX2 can be referred to the SBZ12 (upper Cuisian fide Serra-Kiel et al., 1998; Fig. 3), whereas the samples RSZIVC, RSZVI and CASMIC1 are assigned to lower Lutetian SBZ13 (Fig. 4). The occurrence of *N. gal-*

lensis, *N. polygyratus*, *N. laevigatus* basal form sensu Schaub (1981), and transitional forms such as *Assilina* cf. *maior*, *A. cf. cuvillieri*, *N. cf. friulanus*, suggests that these samples are close to the SBZ12/13 boundary (Fig. 7).

5.2. Calcareous nannofossils

All study samples contain rare to few calcareous nannofossil in a generally moderate to poor state of preservation. Calcareous nannofossil assemblages of all samples are characterized by an extensive Cretaceous and Paleocene reworking. Within these assemblages, *Coccolithus* (mainly the species *Coccolithus pelagicus*) and *Reticulofenestra* largely dominate. *Dictyococcites*, *Cyclicargolithus* and *Ericsonia* are common to few. Sphenoliths are rare to almost common, while *Discoaster* is rare or virtually absent except for samples RSZI and RSZIII. Despite the absence of some marker species (i.e., species of *Nannotetrina*), probably due to their rarity to be observable, we dated most of the samples according to additional events of the Agnini et al. (2014) biozonation, as discussed below. The (semi)quantitative distribution of index species and the relative abundances of *Sphenolithus* are reported in Table S1.

a) *Samples RSZI and RSZIII*. The presence of one specimen of *Blackites inflatus* in both samples, whose lowest occurrences is just below the base of CNE8 Zone, and the absence of specimens of *Sphenolithus spiniger* suggest that the two samples can be attributed to CNE8 Zone. Because the first occurrence of *B. inflatus* marks the base of Lutetian (Molina et al., 2011) these samples can be both assigned to the lower Lutetian.

b) *Samples RSZIVA, B and C*. *Discoaster* and *Sphenolithus* are very rare in the first two samples, and no species can be recognized. The sample RSZIVC contains common sphenoliths, including questionable *S. spiniger*. The presence of *B. inflatus* and the absence of “true” *S. spiniger* suggest the CNE8 Zone, and possibly CNE9 Zone if the presence of *S. spiniger* should be confirmed with further investigations. The occurrence of *B. inflatus* also indicates the lower Lutetian.

c) *Sample RSZVI*. This sample is not suitable for accurate biostratigraphic study because of the scarcity of calcareous nannofossil content. This sample could be assigned to the CNE6 Zone or higher, i.e., Ypresian or more recent, on the basis of a single specimen of *D. sublodoensis*.

d) *Sample CASMIC1*. Here the presence of *B. inflatus*, *S. spiniger* and *D. sublodoensis* indicates upper part of CNE8 and lower part of CNE9 Zones, of the lower Lutetian.

e) *Sample CASMIC2*. Uncertain presence of *B. inflatus* is observed as well as the presence of *D. sublodoensis* and the absence of *S. spiniger*. On this basis the sample can be assigned to CNE6–CNE7 Zone, or, if the presence of *B. inflatus* is confirmed, CNE8 Zone.

f) *Samples CASMIC5 and NOAX2*. Not suitable for accurate biostratigraphic studies because most of index

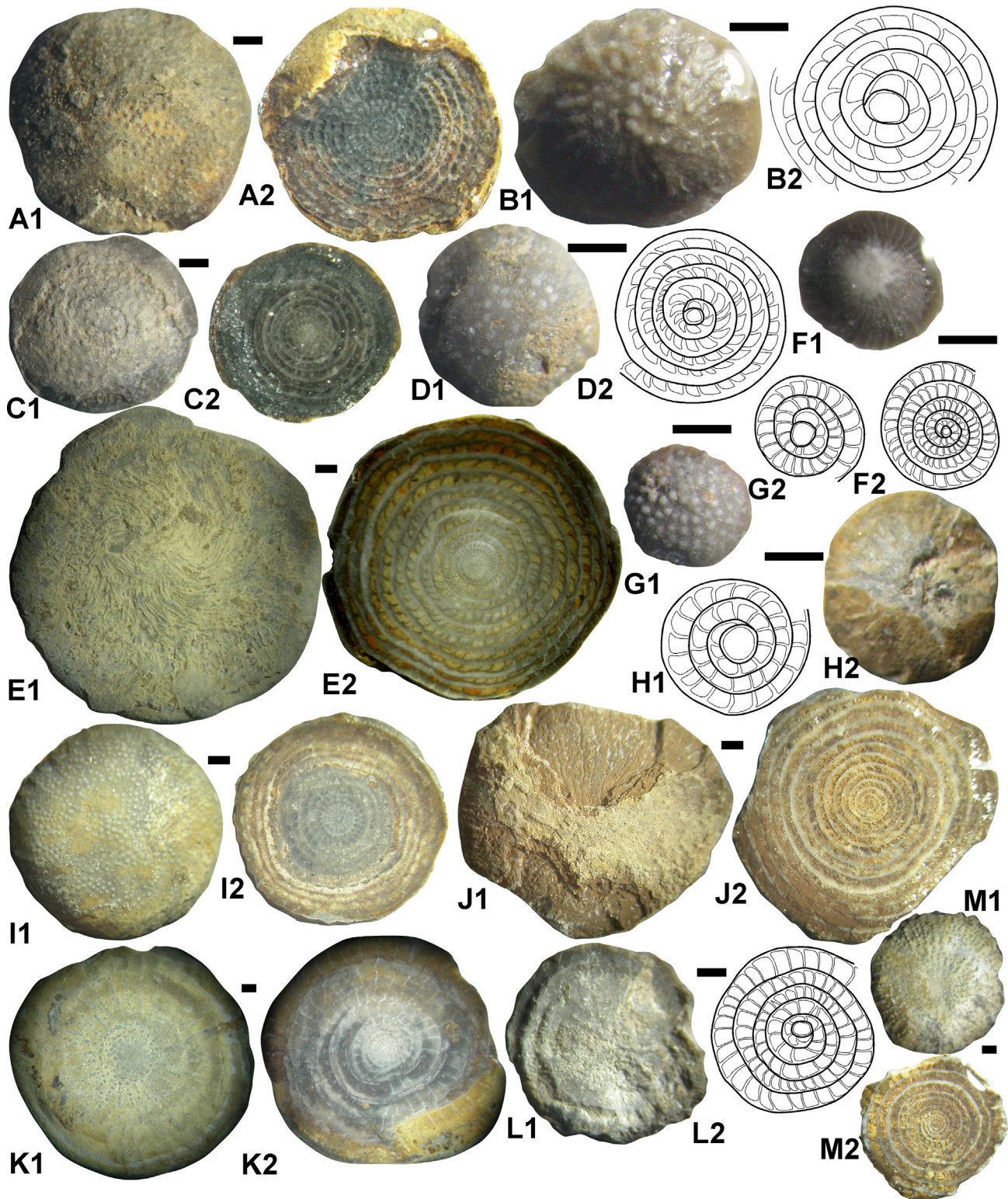

Fig. 3. Selected nummulitids from SBZ12 assemblages. (A) *Nummulites* aff. *gallensis*, B-form, CSA1_NB9. (B, C) *N. friulanus*; (B) A-form, RSZCOR_N4; (C) B-form, CASMIC2_NB16. (D) *N. tauricus*, A-form, RSZIVC_NA11. (E) *N. praelorioli*, B-form, RSZIII_NB1. (F) *N. praediscrobinus*, A-form, RSZCOR_N12. (G) *N. manfredi*, A-form, RSZCOR_NA7. (H, I) *N. quasilaevigata*; (H) A-form, RSZI_NA5; (I) B-form, RSZI_NB1. (J) *N. cf. polygyratus*, B-form, RSZI_ND2. (K, L) *Assilina maior maior*; (K) B-form, CASMC2_A4; (L) A-form, RSZIVA_AB1. (M) *A. cuillieri*, B-form, RSZIII_A6. Scale bar = 1 mm.

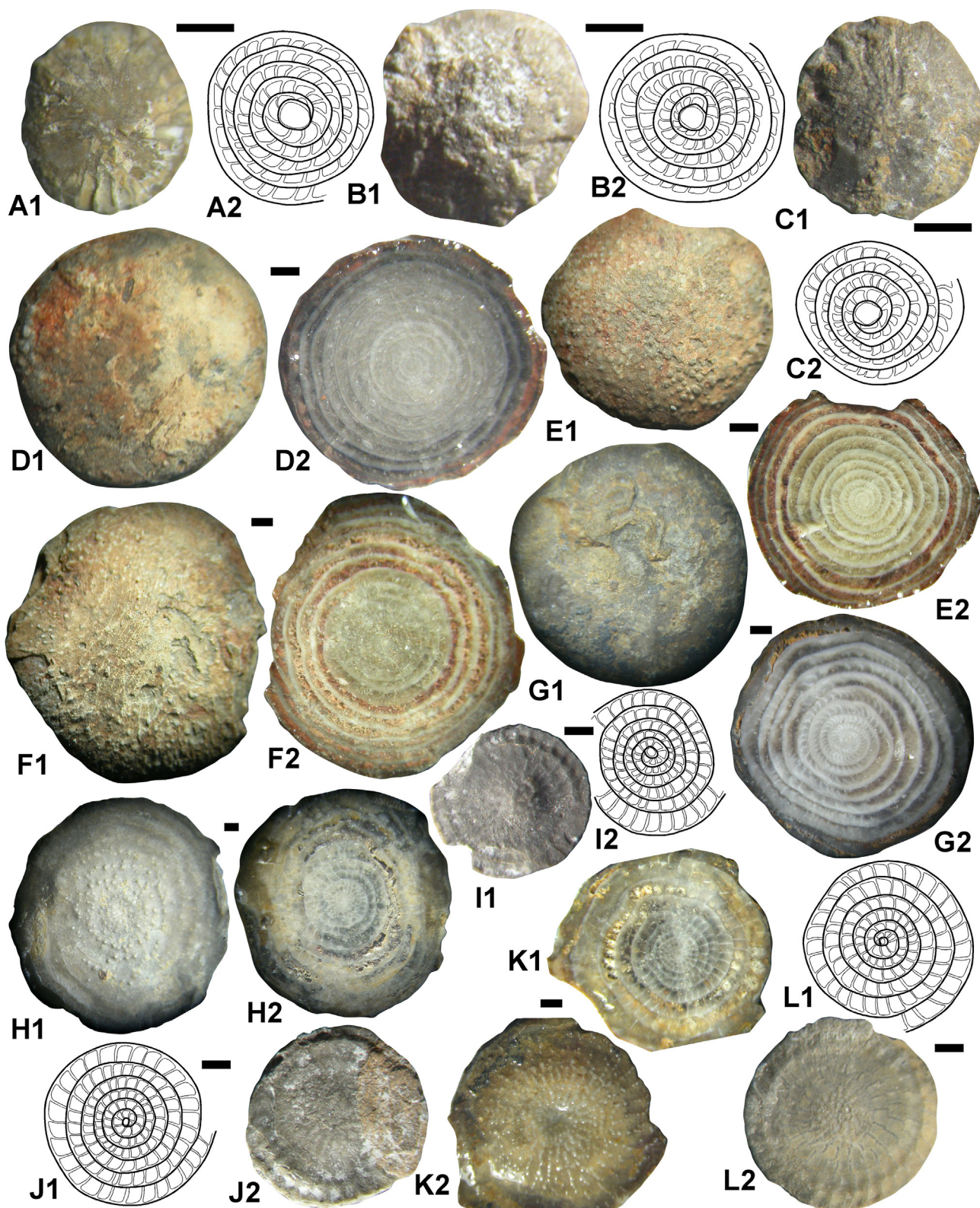

Fig. 4. Selected nummulitids from SBZ13 assemblages. (A) *Nummulites* cf. *campesinus*, A-form, RZIII_NA8. (B) *N.* cf. *gallensis*, A-form, RSZIVC_NA7. (C) *N.* cf. *friulanus*, A-form, RSZIVC_NA12. (D) *N.* *lehneri*, B-form, RSZVI_NB4. (E) *N.* aff. *laevigatus*, B-form, RSZVI_NB10. (F) *N.* *laevigatus*, B-form, RSZVI_NB15. (G) *N.* *polygyratus*, B-form, RSZVI_ND2. (H) *Assilina spira abrardi*, B-form, RSZVI_AS2. (I) *A.* aff. *tenuimarginata*, A-form, CASMIC_AA5. (J) *A.* cf. *cuvillieri*, A-form, CASMIC_ASA1. (K, L) *A.* *tenuimarginata*; (K) B-form, RSZVI_A5; (L) A-form, CASMIC_ASA3. Scale bar = 1 mm.

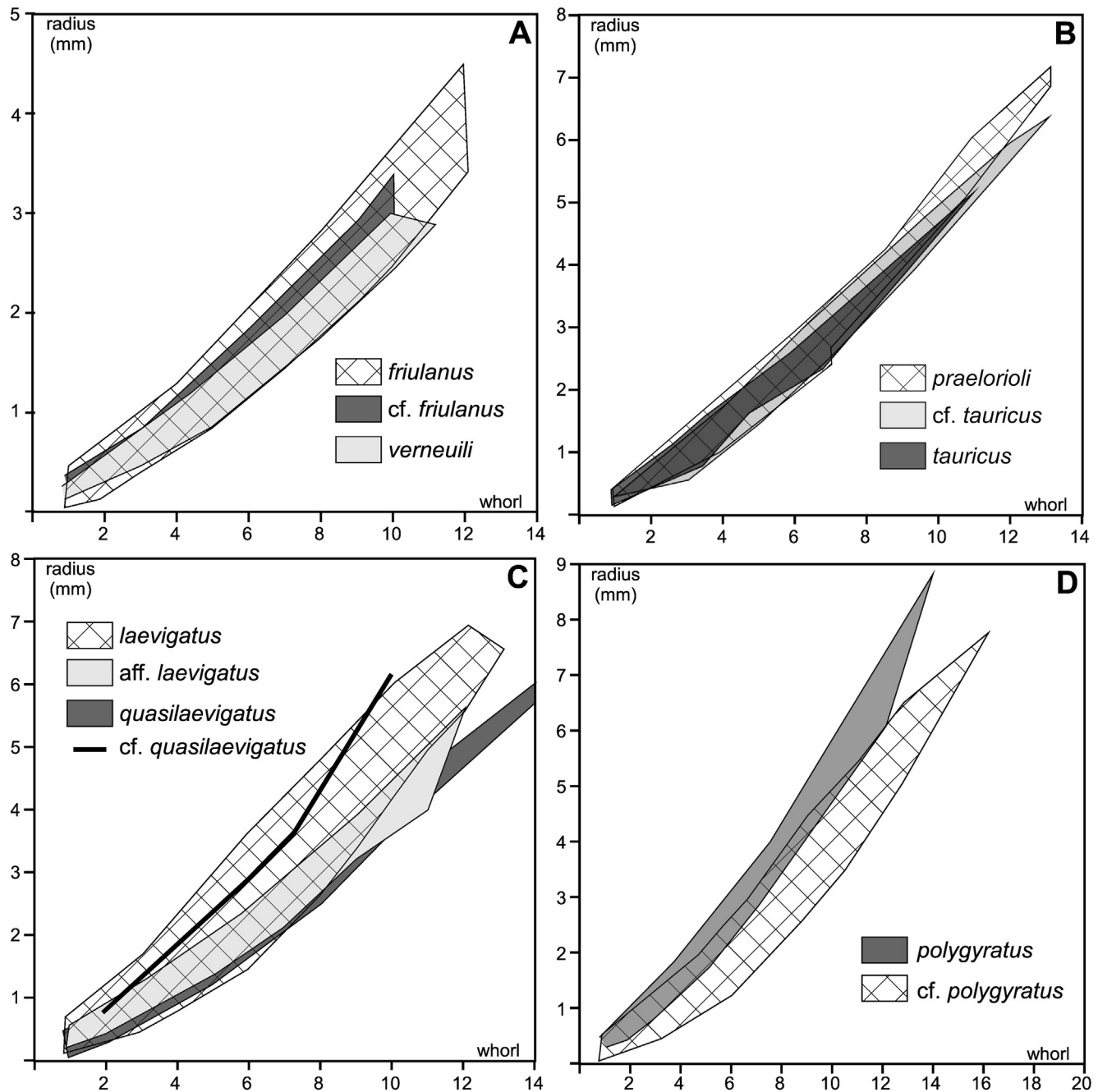

Fig. 5. Spiral diagrams showing the relationship between the number of whorl and radius for selected lineages of *Nummulites* sensu Schaub (1981). (A) *Nummulites verneuili* lineage; (B) *N. partschii* lineage; (C) *N. laevigatus* lineage; (D) *N. distans* lineage.

species are absent. The presence of *Reticulofenestra* and the virtual absence of *Tribrachiatus orthostylus* suggest that the samples might belong to CNE5 Zone or higher, i.e., Ypresian or more recent.

6. Discussion

6.1. Larger foraminiferal diversity at Collio

In summary, a total of 21 species of *Nummulites* (9 of them in open nomenclature) and 9 of *Assilina* (5 in open nomenclature) were recognized in SBZ12 and SBZ13,

respectively, even if the taxa are different in each biozone. As above stated, no Lutetian larger foraminiferal species has been reported from the Flysch di Cormons in the Collio area, and few nummulitids from the upper Cuisian (Schaub, 1981; Cimernan et al., 1974 from the neighbouring Medana beds). The stratigraphic range of each species is discussed in Appendix A.

The diversity appears very high also when compared with the absolute number of nummulitids from the entire Neotethys according to published literature (e.g., Serra-Kiel et al., 1998; Whidden and Jones, 2012) and our ongoing study. In Neotethys, Serra-Kiel et al. (1998) reported a

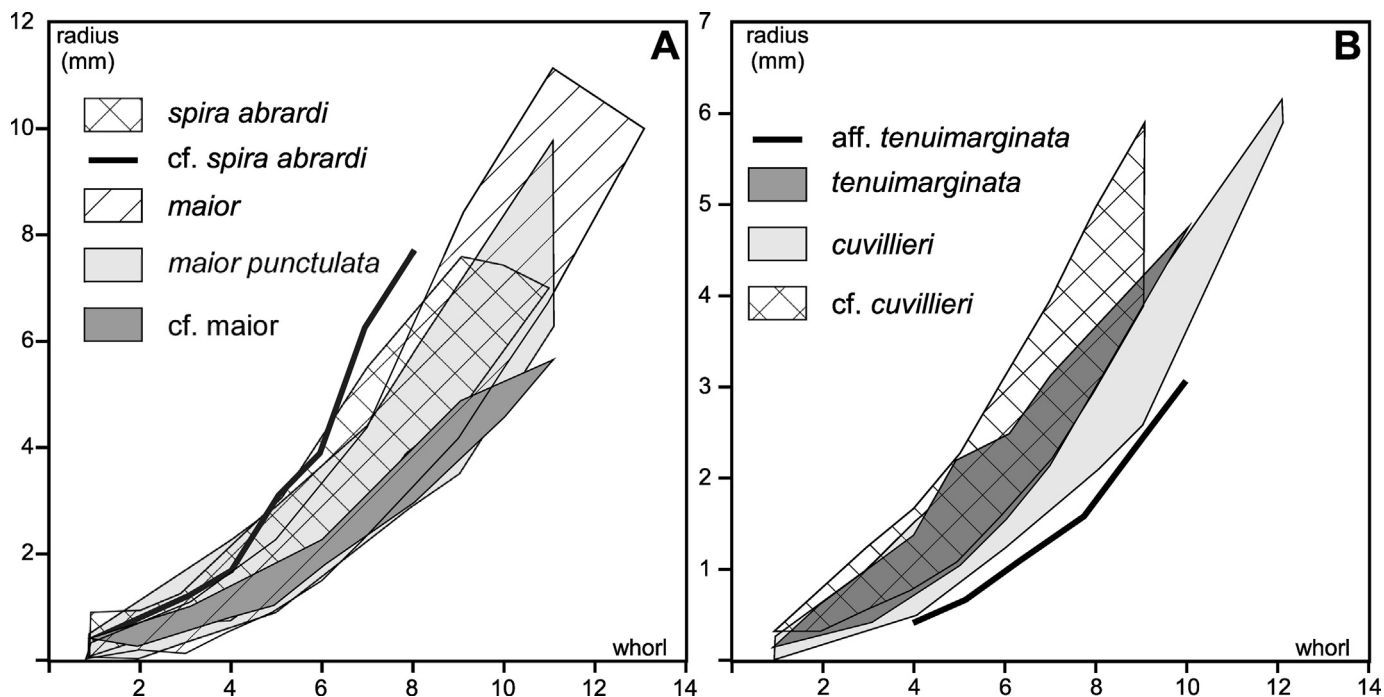

Fig. 6. Spiral diagrams showing the relationship between the number of whorl and radius for selected lineages of *Assilina* sensu Schaub (1981). (A) *Assilina spira* lineage; (B) *Assilina exponents* assemblage.

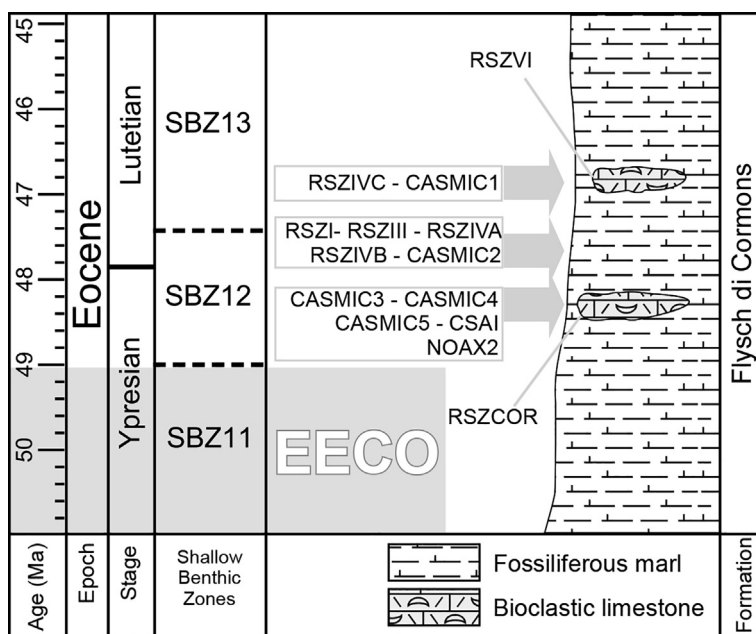

Fig. 7. Position of the investigated samples within the Flysch di Cormons Formation after biostratigraphic analysis. All samples are collected from fossiliferous marls, except RSZCOR and RSZVI (limestone lenses). The positions of shallow benthic zones are revised as discussed in the text. Our samples were collected from the top of the sedimentary succession (after Tunis and Venturini, 1992).

total of 13 species of *Nummulites* and three of *Assilina* in SBZ12, 15 *Nummulites* (three of them appear only in the latest SBZ13) and seven of *Assilina* in SBZ13. Whidden and Jones (2012) in their work on the Paleocene–Eocene diversity of LF, reported 43 nummulitid species from

SBZ12 and 45 from SBZ13. Our preliminary study on Neothethyan larger foraminiferal diversity suggests a total of 33 and 36 species of *Nummulites* (Benedetti and Papazzoni, 2022) and seven and ten *Assilina* (unpublished data) from SBZ12 and SBZ13, respectively.

6.2. Biostratigraphic constraints

The SBZ12/13 boundary has been generally marked as coinciding with Ypresian/Lutetian boundary (e.g., Serra-Kiel et al., 1998; Molina et al., 2011; Mochales et al., 2012; Papazzoni et al., 2017). The base of the Lutetian GSSP has been identified by Molina et al. (2011) in the Gorrondatxe section (Spain) by the first occurrence of the nannofossil *Blackites inflatus* that also marks the base CNE8 of Agnini et al. (2014). Therefore, the occurrence of *B. inflatus* in our samples is a reliable marker of basal Lutetian.

Indeed, Molina et al. (2011; Fig. 7) reported a clear SBZ12 assemblage in the Gorrondatxe section assigning it to the SBZ13 (their sample Az 918). However, this is below the appearance of *Blackites inflatus*, possibly indicating a correlation between SBZ12/13 boundary and the base Lutetian. In the GSSP section there is no continuous occurrence of LF in the turbiditic levels (e.g., Payros et al., 2009). Speijer et al. (2020), in a summary on Paleogene stratigraphy, suggested that the first occurrence of the SBZ13 marker *Nummulites laevigatus* is not consistent with the GSSP boundary.

Rodriguez-Pintó et al. (2022) reached the same conclusion on the basis of the magnetostratigraphic data of the La Puebla de Fantoya succession; however, they did not find in the nannofloras the markers of the base Lutetian.

Based on our data, even from discontinuously collected samples, we document for the first time unambiguously the occurrence of SBZ12 markers from the lowermost Lutetian (samples RSZI, RSZIII, RSZIVA, RSZIVB), according to the presence of *Blackites inflatus*. Therefore, we suggest that the SBZ12/13 boundary must be moved within the lower Lutetian (Fig. 8).

6.3. The aftermath of EECO

Among warming events of the early Cenozoic, the EECO has been a long-lasting phase of increasing temperature and pCO₂ roughly corresponding to SBZ10–11 biozones. This interval experienced the greatest diversity of LF (Hallock and Pomar, 2008), although normalized data could suggest different trends (e.g., Whidden and Jones, 2012). During EECO, shallow water settings were mainly characterized by larger foraminiferal dominated ramps (e.g., Čosović et al., 2004; Benedetti, 2018) that are widely distributed in the whole Neotethys, thus ensuring the recovery of numerous species. The gradual cooling in the post-EECO interval, i.e., SBZ12, evidenced the maximum specific diversity according to Hottinger (2001), which is consistent with our data. This study reveals a very high diversity for the Collio nummulitids, even compared with the entire Neotethyan realm, indicating their resilience after the EECO event. The concomitant occurrence of both A- and B-forms of both *Nummulites* and *Assilina* from most samples, and in the few specimens of *Alveolina* and *Discocyclina* (two unidentifiable individuals from sample CSA1), indicates an essentially autochthonous LF assemblages, with the exception of a few alveolinid tests that are more likely transported from more proximal paleoenvironments.

According to Beavington-Penney and Racey (2004), *Nummulites* thrived from inner to outer shelf environments, *Assilina* from back reef to outer ramp. Hottinger (1997) suggested that assemblages composed by elongated *Alveolina*, thick *Nummulites* and *Assilina* and *Discocyclina* in the early Eocene characterized the upper photic zone, because *Alveolina* is typical of inner ramp to lagoonal settings and protected environments (Geel, 2000; Španiček et al., 2017) or in shoals (Benedetti, 2018), and *Discocyclina*, although also found in shallow-waters (Benedetti, 2018), is characteristic of deeper environment (Beavington-Penney and Racey, 2004; Geel, 2000; Tomassetti and Benedetti, 2020).

7. Conclusions

This study, focusing on LF, especially nummulitids, shows high biodiversity shallow water environment in northeastern Italy during late Ypresian–early Lutetian. The LF tests were deposited along a prograding shelf in a prodelta setting. The larger foraminiferal assemblages indicate a high degree of resilience of shallow-water communities after the EECO long-stand warming event.

Our integrated LF and calcareous nannofossil analysis suggests that the SBZ12/13 boundary, previously considered coincident with the Ypresian/Lutetian boundary, occurs within the lower Lutetian, although further work is needed to better constrain this important transition.

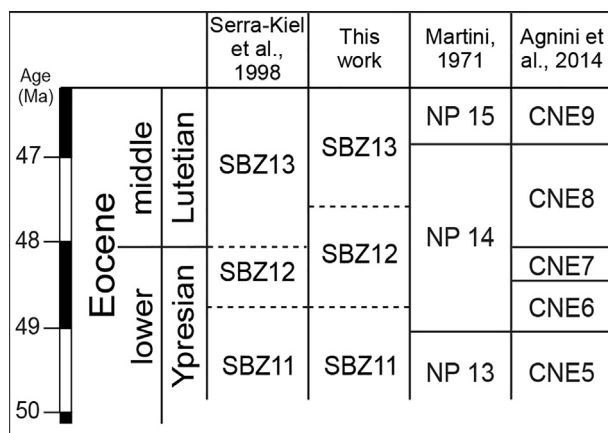

Fig. 8. Biozonation around the Ypresian–Lutetian boundary, with Shallow Benthic Zones (SBZ after Serra-Kiel et al., 1998) and calcareous nanoplankton zones (NP after Martini, 1971 and CNE after Agnini et al., 2014) zones. Time scale after Speijer et al. (2020).

Acknowledgments

We are deeply indebted to Dr. Luca Simonetto (Museo Friulano di Storia Naturale, Udine) for his invaluable assistance in the field and fruitful discussions. This paper greatly benefited from the constructive remarks by the two reviewers Lorenzo Consorti (Consiglio Nazionale delle Ricerche, Trieste) and Vlasta Čosović (Department of Geology, University of Zagreb), and by editorial comments of Qun Yang and Rong-Yu Li.

This work was supported by the Italian Ministry of University and Research (MUR), funds PRIN 2017: project “Biota resilience to global change: biomineralization of planktic and benthic calcifiers in the past, present and future” (prot. 2017RX9XXY).

Supplementary data

Supplementary data to this article can be found online at <https://doi.org/10.1016/j.palwor.2023.01.013>.

References

- Agnini, C., Fornaciari, E., Raffi, I., Catanzariti, R., Pälke, H., Backman, J., Rio, D., 2014. Biozonation and biochronology of Paleogene calcareous nannofossils from low and middle latitudes. *Newsletters on Stratigraphy* 47, 131–181.
- Beavington-Penney, S.J., Racey, A., 2004. Ecology of extant nummulitids and other larger benthic foraminifera: applications in palaeoenvironmental analysis. *Earth-Science Reviews* 67, 219–265.
- Benedetti, A., 2018. Eocene carbonate clasts in Oligocene siliciclastic sediments of the Trapani Basin (NW Sicily): depositional and stratigraphic significance. *Facies* 64, Article number 14, doi: 10.1007/s10347-018-0527-2.
- Benedetti, A., Papazzoni, C.A., 2022. Rise and fall of rotaliid foraminifera across the Paleocene and Eocene times. *Micropaleontology* 68, 185–196.
- Bosellini, F.R., Benedetti, A., Budd, A.F., Papazzoni, C.A., 2022. A coral hotspot from a hot past: the EECO and post-EECO rich reef coral fauna from Friuli (Eocene, NE Italy). *Palaeogeography, Palaeoclimatology, Palaeoecology* 607, 111284.
- Castellarin, A., Vai, G.B., 1982. Introduzione alla geologia strutturale del Sudalpino. In: Castellarin, A., Vai, G.B. (Eds.), *Guida alla Geologia del Sudalpino*. Guide Geologiche Regionali, Società Geologica Italiana, Bologna, pp. 1–22.
- Castellarin, A., Zucchi, M.L., 1963. Ricerche geologiche nell'Eocene di Rosazzo e Noax (Udine). *Giornale di Geologia* 30, 199–213.
- Checchia-Rispoli, G., 1905. Sopra alcune Alveoline eoceniche della Sicilia. *Palaeontographia Italica* 11, 147–167.
- Cimerman, F., Pavlovec, R., Pavšič, J., Todesco, L., 1974. Biostratigrafija paleogenskih plasti v Goriških brdih [Biostratigraphy of the Paleogene beds of Goriška Brda]. *Geologija* 17, 7–130 (in Slovenian, with English and Italian summaries).
- Cucchi, F., Finocchiaro, F., Muscio, G., 2009. Geositi del Friuli Venezia Giulia. Regione Autonoma Friuli-Venezia Giulia – Direzione Centrale Ambiente e Lavori Pubblici, Servizio Geologico, 384 pp.
- Dainelli, G., 1915. L'Eocene Friulano. *Monografia geologica e paleontologica*. Memorie Geografiche, Ricci, Firenze, 721 pp.
- Čosović, V., Drobne, K., Moro, A., 2004. Palaeoenvironmental model for Eocene foraminiferal limestones of the Adriatic carbonate platform (Istrian Peninsula). *Facies* 50, 61–75.
- De Zanche, V., Pavlovec, R., Proto Decima, F., 1967. Microfauna and microfacies of the Eocene Flysch series near Ustje in the Vipava Valley (Vipavska dolina, SW Slovenia). *Razprave Slovenska Akademija Znanosti in Umetnosti* 10 (5), 205–263 (in Slovenian, with English summary).
- Drobne, K., 1977. Alvéolines paléogènes de la Slovénie et de l'Istrie. *Schweizerische Paläontologische Abhandlungen* 99, 1–132.
- Drobne, K., Čosović, V., Moro, A., Bucković, D., 2011. The role of the Paleogene adriatic carbonate platform in the spatial distribution of alveolinids. *Turkish Journal of Earth Sciences* 20, 721–751.
- Drooger, C.W., Marks, P., Papp, A., 1971. Smaller radiate *Nummulites* of Northwestern Europe. *Utrecht Micropaleontological Bulletins* 5, 1–137.
- Faninger, E., Gospodaric, R., Pohar, V., 1962. Geological map of Goriška Brda. Internal Rapport, Geozavod, Ljubljana.
- Gardin, S., Monechi, S., 1998. Palaeoecological change in the middle to low latitude calcareous nannoplankton at the Cretaceous/Tertiary boundary. *Bulletin de la Société Géologique de France* 5, 709–723.
- Geel, T., 2000. Recognition of stratigraphic sequence in carbonate platform and slope deposits: empirical models based on microfacies analysis of Palaeogene deposits in south-eastern Spain. *Palaeogeography, Palaeoclimatology, Palaeoecology* 155, 211–238.
- Hallock, P., Pomar, L., 2008. Cenozoic evolution of larger benthic foraminifera: paleoceanographic evidence for changing habitats. In: Riegl, B., Dodge, R.E. (Eds.), *Proceedings of the 11th International Coral Reef Symposium*, Ft. Lauderdale, Florida, 7–11 July 2008. Halmos College of Natural Sciences and Oceanography at Nova Southeastern University, Florida, pp. 16–20.
- Hohenegger, J., 2011. Large Foraminifera: Greenhouse Constructions and Gardeners in the Oceanic Microcosm. Kagoshima University Museum, Kagoshima, 81 pp.
- Hottinger, L., 1960. Recherches sur les Alvéolines du Paléocène et de l'Éocène. *Schweizerische Paläontologische Abhandlungen* 75–76, 1–243.
- Hottinger, L., 1997. Shallow benthic foraminiferal assemblages as signals for depth of their deposition and their limitation. *Bulletin de la Société Géologique de France* 168, 491–505.
- Hottinger, L., 2001. Learning from the Past? In: Levi-Montalcini, R. (Ed.), *Frontiers of Life* 4 (2), Discovery and Spoliation of the Biosphere. Academic Press, London and San Diego, pp. 449–477.
- Hottinger, L., 2014. Paleogene Larger Rotaliid Foraminifera from the Western and Central Neotethys. Springer, Berlin, 191 pp.
- Less, G., 1999. The late Paleogene larger foraminiferal assemblages of the Bükk Mts. (NE Hungary). *Revista Española de Micropaleontología* 31, 51–60.
- Less, G., Özcan, E., Papazzoni, C.A., Stöckar, R., 2008. The middle to late Eocene evolution of nummulitid foraminifer *Heterostegina* in the Western Tethys. *Acta Palaeontologica Polonica* 53, 317–350.
- Luciani, V., Dickens, G.R., Backman, J., Fornaciari, E., Giusberti, L., Agnini, C., D'Onofrio, R., 2016. Major perturbations in the global carbon cycle and photosymbiont-bearing planktic foraminifera during the early Eocene. *Climate of the Past* 12, 981–1007.
- Maddaleni, P., 1997. I coralli di Russiz nel Collio Orientale (Luteziano inferiore, Gorizia, Italia Nord-Orientale). *Gortania, Atti del Museo Friulano di Storia Naturale* 19, 61–84.
- Maddaleni, P., Tunis, G., 1993. Il litosoma conglomeratico ad echinidi di Buttrio (Udine, NE Italia). *Gortania, Atti del Museo Friulano di Storia Naturale* 15, 33–48.
- Martini, E., 1971. Standard Tertiary and Quaternary calcareous nannoplankton zonation. In: Farinacci, A. (Ed.), *Proceedings 2nd International Conference Planktonic Microfossils*. Tecnoscienza, Rome, Vol. 2, pp. 739–785.
- Martinis, B., 1962. Ricerche geologiche e paleontologiche sulla regione compresa fra il T. Judrio e il F. Timavo. *Memorie della Rivista Italiana di Paleontologia e Stratigrafia* 8, 1–200.
- Mochales, T., Barnolas, A., Pueyo, E.L., Casas, A.M., Serra-Kiel, J., Samsó, J.M., Ramajo, J., 2012. Chronostratigraphy of the Boltaña anticline and the Ainsa Basin (Southern Pyrenees). *Geological Society of America Bulletin* 124, 1229–1250.

- Molina, E., Alegret, L., Apellaniz, E., Bernaola, G., Caballero, F., Dinarès-Turell, J., Hardenbol, J., Heilmann-Clausen, C., Larrasoana, J.C., Luterbacher, H., Monechi, S., Ortiz, S., Orue-Etxebarria, X., Payros, A., Pujalte, V., Rodríguez-Tovar, F.J., Tori, F., Tosquella, J., Uchman, A., 2011. The Global Stratotype Section and Point (GSSP) for the base of the Lutetian Stage at the Gorrondatxe section, Spain. *Episodes* 34, 86–108.
- Papazzoni, C.A., Čosović, V., Briguglio, A., Drobne, K., 2017. Towards a calibrated larger foraminifera biostratigraphic zonation: celebrating 18 years of the application of shallow benthic zones. *Palaios* 32, 1–5.
- Pavlovec, R., 1966. Paleogene strata in Goriška Brda (Western Yugoslavia). *Bulletin Scientifique Conseil des Academies de la RPF Yugoslavie A* 11, 243–244.
- Pavlovec, R., 2012. The nummulitins from the Outer Dinarids. *Folia Biologica et Geologica* 53 (3), 85–109.
- Payros, A., Tosquella, J., Bernaola, G., Dinarès-Turell, J., Orue-Etxebarria, X., Pujalte, V., 2009. Filling the North European Early/Middle Eocene (Ypresian/Lutetian) boundary gap: Insights from the Pyrenean continental to deep-marine record. *Palaeogeography, Palaeoclimatology, Palaeoecology* 280, 313–332.
- Perch-Nielsen, K., 1985. Cenozoic calcareous nannofossils. In: Bolli, H. M., Saunders, J.B., Perch-Nielsen, K. (Eds.), *Plankton Stratigraphy*. Cambridge University Press, Cambridge, pp. 427–554.
- Piccoli, G., Proto Decima, F., 1969. Ricerche biostratigrafiche sui depositi flyschoidi della regione adriatica settentrionale e orientale. *Memorie degli Istituti di Geologia e Mineralogia dell'Università di Padova* 27, 1–23.
- Rio, D., Fornaciari, E., Raffi, I., 1990. Late Oligocene through early Pleistocene calcareous nannofossils from western equatorial Indian Ocean (Leg 115). In: Duncan, R.A., Backman, J., Peterson, L.C. et al. (Eds.), *Proceedings of the Ocean Drilling Program, Scientific Results, 115*. Ocean Drilling Program, College Station, TX, pp. 175–235, doi: 10.2973/odp.proc.sr.115.152.1990.
- Rodríguez-Pintó, A., Serra-Kiel, J., Bernaola, G., Barnolas, A., Pueyo, E. L., Tosquella, J., Arbues, P., Scholger, R., 2022. The early/middle Eocene transition at the Ésera valley (South-Central Pyrenees): implications in Shallow Benthic Zones (SBZ). *Geologica Acta* 20 (6), 1–25.
- Schaub, H., 1962. Über einige stratigraphisch wichtige Nummuliten-Arten. *Eclogae Geologicae Helveticae* 55, 529–551.
- Schaub, H., 1981. Nummulites et Assilines de la Téthys paléogène: taxonomie, phylogénèse et biostratigraphie. *Schweizerische Palaontologische Abhandlungen* 104, 1–236.
- Serra-Kiel, J., Hottinger, L., Caus, E., Drobne, K., Ferrández, C., Jauhri, A.K., Less, G., Pavlovec, R., Pignatti, J., Samsó, J.M., Schaub, H., Sirel, Strougo, A., Tambareau, Y., Tosquella, J., Zakrevskaya, E., 1998. Larger foraminiferal biostratigraphy of the Tethyan Paleocene and Eocene. *Bulletin de la Société Géologique de France* 169, 281–299.
- Španiček, J., Čosović, V., Mrinjek, E., Vlahović, I., 2017. Early Eocene evolution of carbonate depositional environments recorded in the Čikola Canyon (North Dalmatian Foreland Basin, Croatia). *Geologica Croatica* 70, 11–25.
- Speijer, R.P., Pälike, H., Hollis, C.J., Hooker, J.J., Ogg, J.G., 2020. Chapter 28 – The Paleogene Period. In: Gradstein, F.M., Ogg, J.G., Schmitz, M.D., Ogg, G.M. (Eds.), *Geologic Time Scale 2020*. Elsevier, Amsterdam, pp. 1087–1140.
- Tomassetti, L., Benedetti, A., 2020. To be allochthonous or autochthonous? The late Paleocene–late Eocene slope sedimentary succession of the Latium-Abruzzi carbonate platform (Central Apennines, Italy). *Facies* 66, Article number 6, doi: 10.1007/s10347-019-0590-3.
- Tunis, G., Pirini Radrizzani, C., 1987. Flyschoid deposits of Goriška Brda (Collio) between Soča (Isonzo) River and Ifija (Iudrio). *Geologija* 30, 123–148.
- Tunis, G., Venturini, S., 1992. Evolution of the southern margin of the Julian Basin with emphasis on the megabeds and turbidites sequence of the Southern Julian Prealps (NE Italy). *Geologia Croatica* 45, 127–150.
- Venturini, S., Tunis, G., 1989. Nuovi dati ed interpretazioni sulla tettonica del settore meridionale delle Prealpi Giulie e della regione al confine tra Italia e Jugoslavia. Gortania, *Atti del Museo Friulano di Storia Naturale* 10 [1988], 5–34.
- Venturini, S., Tunis, G., 1992a. Nuovi dati stratigrafici, paleoambientali e tettonici sul Flysch di Cormons (Friuli Orientale). Gortania, *Atti del Museo Friulano di Storia Naturale* 13 [1991], 5–30.
- Venturini, S., Tunis, G., 1992b. La composizione dei conglomerati cenozoici del Friuli: dati preliminari. *Studi Geologici Camerti, Volume Speciale 1992/2*, 285–295.
- Whidden, K.J., Jones, R.W., 2012. Correlation of early Paleogene global diversity patterns of large benthic foraminifera with Paleocene and Eocene climatic events. *Palaios* 27, 235–251.
- Young, J.R., Bown, P.R., Lees, J.A., 2017. Nannotax3 Website. International Nannoplankton Association, available at: www.mikrotax.org/Nannotax3, accessed 21st Apr 2017.
- Zachos, J.C., Pagani, M., Sloan, L., Thomas, E., Billups, K., 2001. Trends, rhythms and aberrations in global climate 65 Ma to present. *Science* 292, 686–693.
- Zanferrari, A., Avigliani, R., Monegato, G., Paiero, G., Poli M.E., 2008. Note illustrative della Carta geologica d'Italia alla scala 1:50.000 – Foglio 066 “Udine”. APAT-Servizio Geologico d'Italia – Regione A. Friuli Venezia Giulia. SELCA, Firenze, 176 pp.