



Volume-Level Calibrations for Partially-filled Liquid Process and Storage Vessels: Metering for Complex Geometries

T. A. Oshin^{1,2*} , O. O. Agboola³, C. E. Ichebi¹, D. O. Ajani¹ and D. O. Balogun¹

¹Department of Chemical Engineering, Landmark University, P.M.B. 1001, Omu-Aran, Kwara State, Nigeria

²Landmark University SDG 9 Research Cluster (Industry, Innovation and Infrastructure), P.M.B. 1001, Omu-Aran, Kwara State, Nigeria

³Department of Mechanical Engineering, Landmark University, P.M.B. 1001, Omu-Aran, Kwara State, Nigeria

Received: 21 January 2023 / Accepted: 22 May 2023

© Metrology Society of India 2023

Abstract: Process vessels utilized for liquids and liquid-phase processes are important in the chemical process industries as they are employed for a number of purposes which include use as reservoirs, surge tanks, transportation tankers and as reactors. It is therefore often desired to have real-time data about the liquid volume and level especially for partially-filled vessels. While obtaining volume-level data for filled tanks for common geometries are simple tasks, this is not so for partially-filled vessels with complex geometries. This paper therefore sets out to develop a useful theoretical tool which can assist process engineers with the task of calibrating process tanks for these complex yet widely-used geometries. The paper presents a mathematical analysis of these geometries and develops equations and charts which could be used to estimate tank volumes from given depth of liquid for any geometry of partially-filled process vessel. The paper also develops a useful methodology which can assist in the design and sizing of process vessels using the developed charts. The paper is unique in that it utilized a normalization technique in the mathematical analyses of the partially-filled process vessels. Fractional volume and fractional depth were introduced as key variables in addition to dimensionless geometric parameters.

Keywords: Storage tank; Process vessel; Calibration; Unit operation; Level control; Tank volume calculation; Partially-filled tank

1. Introduction

Liquid process vessels feature frequently in the chemical process industries as indispensable units utilized for a number of functions which include storage, buffering, surge-control, reservoir and reactions. In the downstream process industries involving transport and distribution of liquid products, the transportation tankers used are some form of process vessels. The umbrella of usage of liquid storage tanks and vessels even transcends the common process applications to include unconventional terrains like the storage of wastewater and eventual discharge to river basins [1], the transportation of liquid wastes, groundwater reservoirs [2] and overhead reservoirs for surface water storage [3]. Whether as storage tanks, transportation

tankers, buffer tanks, holding tanks or as reactors, it is often the desire to determine the volume and depth of liquid in process vessels especially when they are partially-filled. This volume-level information is a requirement of proper calibration which is often a daunting task.

While calibration is easy for simple geometries like vertical cylindrical and cuboidal tanks, for other complex geometries like horizontal cylinders and other cylindrical composites, this is not quite easy, leaving the process engineer with a task of experimentally calibrating the vessel. Calibration and metering of process vessels is crucial to continuous plant operation as volume-level information are useful for process control purposes, process monitoring and often for troubleshooting. Calibration gives the relationship between measured level and measured volume and it is important to ensure that, throughout the life cycle of the vessel, what was obtained during

*Corresponding author, E-mail: oshin.temitope@lmu.edu.ng

commissioning do not change over time [4]. Hence, the need for calibration charts.

Calibration charts are tank capacity tables which show the quantity of fluid in a containment system at a given level, depth or height [5–7]. There are now storage tanks having a capacity as high as 240,000 m³ and therefore one can see how important the calibration of storage tanks can be. Because of this, Yeandle [8] claimed in his article that any calibration-stage error will result in a significant inaccuracy in the tank table, the consequences of which will be detrimental.

Calibration charts showing the calibrated volume at every incremental level can be developed using mathematical equations derived for the known geometrical shapes of vessels. The use of mathematical equations to establish volume-level relationship is known as Geometrical or Dry Calibration [9, 10]. Geometrical method of vessel or tank calibration is adjudged to be faster in generating tank calibration charts but the accuracy is less when compared with the Wet method of tank calibration. In contrast to the dry method, though wet calibration is more accurate, however, it takes longer time, it is limited to small-sized vessels (about 60m³), and it is not economical [11].

This paper therefore sets out to develop a useful tool which can assist professional engineers with the task of calibrating process tanks for these complex yet widely-used geometries without experimentation. The paper presents a mathematical analysis of these geometries and develops charts which could be used to estimate tank volumes from given depth of liquid for any geometry of partially-filled process vessels. The paper also develops a useful methodology which can assist in the design and sizing of process vessels using the developed charts. The objectives of this research are three-fold. Firstly, the research's goal is to develop a useful resource to assist in the design and sizing of process vessels. Secondly, it is set out to help in the determination of tank volumes given the depth of liquid for any geometry of partially-filled process vessels. Lastly, it presents a methodology based on mathematical analyses for the calibration of partially-filled liquid process vessels.

Uniquely, this paper employed a normalization technique in the mathematical analyses of the partially-filled process vessels considered in the work. It introduces fractional volume and fractional depth as time-dependent variables for a partially-filled process vessel. In addition, dimensionless geometric parameters are introduced as design parameters for each process vessel in terms of the key dimensions of the geometrical shape or composite shapes of the vessel. The advantage of this novel analytical approach to the study of volume-level calibration of partially-filled process vessels is that generalizations about the

relationships between the volume and the liquid depth for any of the geometries and composites considered can be made in the closed interval of $0 \leq x \leq 1$ specifying only the dimensionless geometric parameters.

2. Analyses of Partially-Filled Vessel Geometries

2.1. Ellipsoidal Vessel

Figure 1 shows a partially-filled ellipsoidal vessel filled to a depth, h . The ellipsoidal vessel has characteristic dimensions $2a$, $2b$ and $2c$ on its three axes. The total depth or height is $H = 2c$. The partially-filled volume at a depth h is

$$V = \frac{\pi ab}{3c^2} h^2 (3c - h) \quad (1)$$

or

$$V = \frac{4\pi ab}{3H^2} h^2 \left(\frac{3}{2}H - h \right) \quad (2)$$

At maximum capacity, the maximum volume is

$$V_{\max} = \frac{2}{3} \pi ab \quad (3)$$

By dividing Eq. (2) by (3) and introducing the fractional volume \forall and fractional depth \bar{h} , we obtain the normalized volume-level relationship for an ellipsoidal tank as

$$\forall = 3 \left(\frac{h}{H} \right)^2 - 2 \left(\frac{h}{H} \right)^3$$

$$\forall = 3\bar{h}^2 - 2\bar{h}^3 \quad (4)$$

where

$$\forall = \frac{V}{V_{\max}} \quad (5)$$

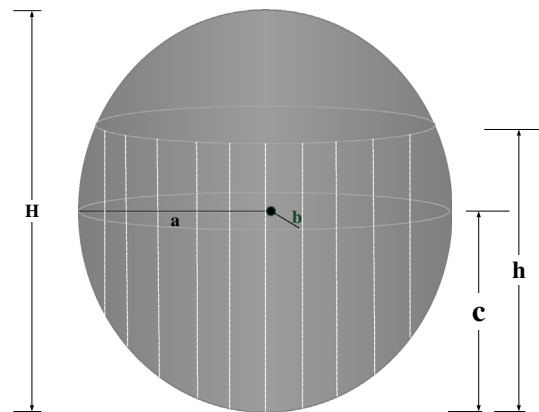

Fig. 1 Partially-filled ellipsoidal vessel

$$\bar{h} = \frac{h}{H} = \frac{h}{2c} \tag{6}$$

Equation (4) is graphed in Fig. 2.

2.2. Spherical Vessel

The spherical vessel can be considered as a special case of the ellipsoidal vessel (Fig. 1) where $a = b = c = R$ and $H = 2R$. Therefore, the partially-filled volume for a depth of h follows from Eq. (1) as

$$V = \frac{\pi}{3}h^2(3R - h) \tag{7}$$

At full capacity, the volume is at the maximum and is given by

$$V_{\max} = \frac{4}{3}\pi R^3 \tag{8}$$

When Eq. (7) is divided by (8), we obtain an expression similar to Eq. (4) from which it follows then that the expression for the fractional volume \bar{V} for a spherical tank is the same as that for the ellipsoidal tank, only that in this case the fractional depth is

$$\bar{h} = \frac{h}{H} = \frac{h}{2R} \tag{9}$$

where R is the radius of the spherical tank.

The chart of Fig. 2 is also applicable to the spherical tank.

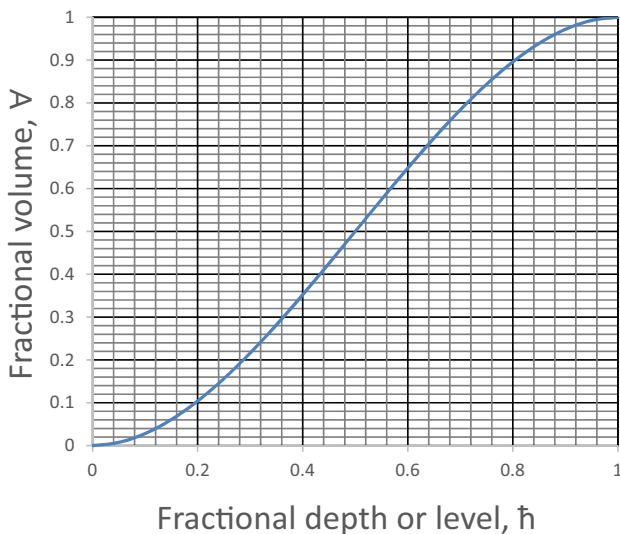

Fig. 2 Volume-level relationship for a partially-filled ellipsoidal or spherical vessel

2.3. Horizontal Cylinders

2.3.1. Elliptic Horizontal Cylinders

Consider a horizontal cylinder of length L (Fig. 3) partially filled with liquid to a depth of h whose cross-section is an ellipse of major axis $2a$ and minor axis $2b$.

By obtaining the area occupied by the liquid in the elliptic cross-section and multiplying this by the length of the tank, the volume of the liquid is obtained. (This is a general approach to obtaining the volume of all prisms to which the flat-end horizontal cylinders belong except for the composites among them with domed ends).

That is,

$$V = A \cdot L \tag{10}$$

The cross-section is shown in Fig. 4 on the x - y plane with a convenient choice of origin such that the centre of the ellipse is located at (a, b) .

From Fig. 4, the area of the occupied (shaded) segment of the ellipse is

$$A = \text{Area of elliptic sector } POR - \text{Area of triangle } POR$$

$$A = \theta ab - \frac{1}{2}|PR| \cdot |OQ| \tag{11}$$

where $\theta(0 \leq \theta \leq \pi)$ obtained from the trigonometric ratios is defined by Eq. (12) by considering triangle POQ.

$$\theta = \cos^{-1}\left(\frac{|OQ|}{|OP|}\right) = \sin^{-1}\left(\frac{|PQ|}{|OP|}\right) = \tan^{-1}\left(\frac{|PQ|}{|OQ|}\right) \tag{12}$$

Since $P(x_1, h)$ and $R(x_2, h)$ are points of intersection of the line $y = h$ and the ellipse $\left(\frac{x}{a} - 1\right)^2 + \left(\frac{y}{b} - 1\right)^2 = 1$, we obtain x_1 and x_2 by simultaneous solution of the two curves thus:

$$\left(\frac{x}{a} - 1\right)^2 = 1 - \left(\frac{h}{b} - 1\right)^2 = 4\left(\frac{h}{2b}\right) - 4\left(\frac{h}{2b}\right)^2 \tag{13}$$

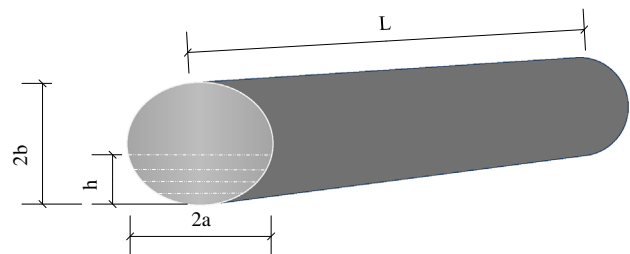

Fig. 3 Partially-filled horizontal cylinder with elliptic cross-section

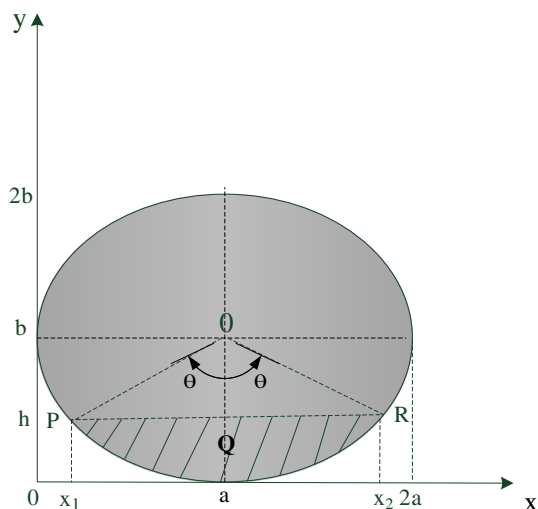

Fig. 4 The elliptic cross-section of the horizontal cylinder on the x - y cartesian plane

$$\frac{x_1}{a} = 1 - 2\sqrt{\left(\frac{h}{2b}\right) - \left(\frac{h}{2b}\right)^2} \quad (14)$$

$$\frac{x_2}{a} = 1 + 2\sqrt{\left(\frac{h}{2b}\right) - \left(\frac{h}{2b}\right)^2} \quad (15)$$

So,

$$|PR| = x_2 - x_1 = 4a\sqrt{\left(\frac{h}{2b}\right) - \left(\frac{h}{2b}\right)^2} \quad (16)$$

By the application of Pythagoras' theorem to either of triangles POQ and ROQ noting that

$$|OQ| = b - h \quad (17)$$

$$|PQ| = |QR| = 2a\sqrt{\left(\frac{h}{2b}\right) - \left(\frac{h}{2b}\right)^2} \quad (18)$$

we obtain

$$|OP|^2 = |OR|^2 = (b - h)^2 + \left[2a\sqrt{\left(\frac{h}{2b}\right) - \left(\frac{h}{2b}\right)^2}\right]^2 \quad (19)$$

$$|OP| = |OR| = 2b\sqrt{\left[\left(\frac{a}{b}\right)^2 - 1\right]\left[\left(\frac{h}{2b}\right) - \left(\frac{h}{2b}\right)^2\right] + \frac{1}{4}} \quad (20)$$

Now, substituting the known line segments $|PR|$ and $|OQ|$ into Eq. (11), the area becomes

$$A = \theta ab - \frac{1}{2} \cdot (b - h) \cdot 4a\sqrt{\left(\frac{h}{2b}\right) - \left(\frac{h}{2b}\right)^2} \quad (21)$$

$$A = ab \left[\theta - 4\left(\frac{1}{2} - \frac{h}{2b}\right) \cdot \sqrt{\left(\frac{h}{2b}\right) - \left(\frac{h}{2b}\right)^2} \right] \quad (22)$$

And consequently, the occupied volume is given by

$$V = abL \left[\theta - 4\left(\frac{1}{2} - \frac{h}{2b}\right) \cdot \sqrt{\left(\frac{h}{2b}\right) - \left(\frac{h}{2b}\right)^2} \right] \quad (23)$$

From Eq. (12), θ ($0 \leq \theta \leq \pi$) has the following expressions when we substitute Eqs. (17), (18) and (20)

$$\theta = \cos^{-1} \left\{ \frac{\frac{1}{2} - \frac{h}{2b}}{\sqrt{\left[\left(\frac{a}{b}\right)^2 - 1\right]\left[\left(\frac{h}{2b}\right) - \left(\frac{h}{2b}\right)^2\right] + \frac{1}{4}}} \right\} \quad (24)$$

$$\theta = \sin^{-1} \left\{ \frac{\left(\frac{a}{b}\right)\sqrt{\left(\frac{h}{2b}\right) - \left(\frac{h}{2b}\right)^2}}{\sqrt{\left[\left(\frac{a}{b}\right)^2 - 1\right]\left[\left(\frac{h}{2b}\right) - \left(\frac{h}{2b}\right)^2\right] + \frac{1}{4}}} \right\} \quad (25)$$

$$\theta = \tan^{-1} \left\{ \frac{\left(\frac{a}{b}\right)\sqrt{\left(\frac{h}{2b}\right) - \left(\frac{h}{2b}\right)^2}}{\frac{1}{2} - \frac{h}{2b}} \right\} \quad (26)$$

Any of Eqs. (24), (25) and (26) which gives θ as a function of liquid level h can be used in Eq. (23). Therefore, the partially-filled volume is given by any of Eqs. (27), (28) and (29).

$$V = abL \left[\cos^{-1} \left\{ \frac{\frac{1}{2} - \frac{h}{2b}}{\sqrt{\left[\left(\frac{a}{b}\right)^2 - 1\right]\left[\left(\frac{h}{2b}\right) - \left(\frac{h}{2b}\right)^2\right] + \frac{1}{4}}} \right\} - 4\left(\frac{1}{2} - \frac{h}{2b}\right) \cdot \sqrt{\left(\frac{h}{2b}\right) - \left(\frac{h}{2b}\right)^2} \right] \quad (27)$$

$$V = abL \left[\sin^{-1} \left\{ \frac{\left(\frac{a}{b}\right) \sqrt{\left(\frac{h}{2b}\right) - \left(\frac{h}{2b}\right)^2}}{\sqrt{\left[\left(\frac{a}{b}\right)^2 - 1\right] \left[\left(\frac{h}{2b}\right) - \left(\frac{h}{2b}\right)^2\right] + \frac{1}{4}}}\right\} - 4 \left(\frac{1}{2} - \frac{h}{2b}\right) \cdot \sqrt{\left(\frac{h}{2b}\right) - \left(\frac{h}{2b}\right)^2} \right] \tag{28}$$

$$V = abL \left[\tan^{-1} \left\{ \frac{\left(\frac{a}{b}\right) \sqrt{\left(\frac{h}{2b}\right) - \left(\frac{h}{2b}\right)^2}}{\frac{1}{2} - \frac{h}{2b}}\right\} - 4 \left(\frac{1}{2} - \frac{h}{2b}\right) \cdot \sqrt{\left(\frac{h}{2b}\right) - \left(\frac{h}{2b}\right)^2} \right] \tag{29}$$

where $0 \leq h \leq 2b$.

At maximum capacity when the tank is full, $h = 2b$, and the volume is

$$V_{\max} = \pi ab \tag{30}$$

If we define a dimensionless volume

$$\forall = \frac{V}{V_{\max}}$$

as the fraction of the maximum capacity of the tank occupied by the liquid, we obtain the expressions in (Eqs. 31)–(33)

$$\forall = \frac{1}{\pi} \left[\cos^{-1} \left\{ \frac{\frac{1}{2} - \bar{h}}{\sqrt{\left[\left(\frac{a}{b}\right)^2 - 1\right] [\bar{h} - \bar{h}^2] + \frac{1}{4}}}\right\} - 4 \left(\frac{1}{2} - \bar{h}\right) \cdot \sqrt{\bar{h} - \bar{h}^2} \right] \tag{31}$$

$$\forall = \frac{1}{\pi} \left[\sin^{-1} \left\{ \frac{\left(\frac{a}{b}\right) \sqrt{\bar{h} - \bar{h}^2}}{\sqrt{\left[\left(\frac{a}{b}\right)^2 - 1\right] [\bar{h} - \bar{h}^2] + \frac{1}{4}}}\right\} - 4 \left(\frac{1}{2} - \bar{h}\right) \cdot \sqrt{\bar{h} - \bar{h}^2} \right] \tag{32}$$

$$\forall = \frac{1}{\pi} \left[\tan^{-1} \left\{ \frac{\left(\frac{a}{b}\right) \sqrt{\bar{h} - \bar{h}^2}}{\frac{1}{2} - \bar{h}}\right\} - 4 \left(\frac{1}{2} - \bar{h}\right) \cdot \sqrt{\bar{h} - \bar{h}^2} \right] \tag{33}$$

where \bar{h} is the partially-filled liquid level expressed as a fraction of the maximum depth of $2b$. That is,

$$\bar{h} = \frac{h}{2b} \tag{34}$$

A dimensionless parameter, the eccentricity, e , is of common use to describe ellipses. For the elliptic cross-section of Fig. 5 with major axis $2a$ and minor axis $2b$, it is defined as

$$e^2 = 1 - \frac{b^2}{a^2}, 0 < e < 1 \text{ for } a > b > 0 \tag{35}$$

Equations (31)–(33) can be re-written to include the eccentricity,

Fig. 5 Volume-level relationships for the elliptic horizontal cylinder at different eccentricities, e

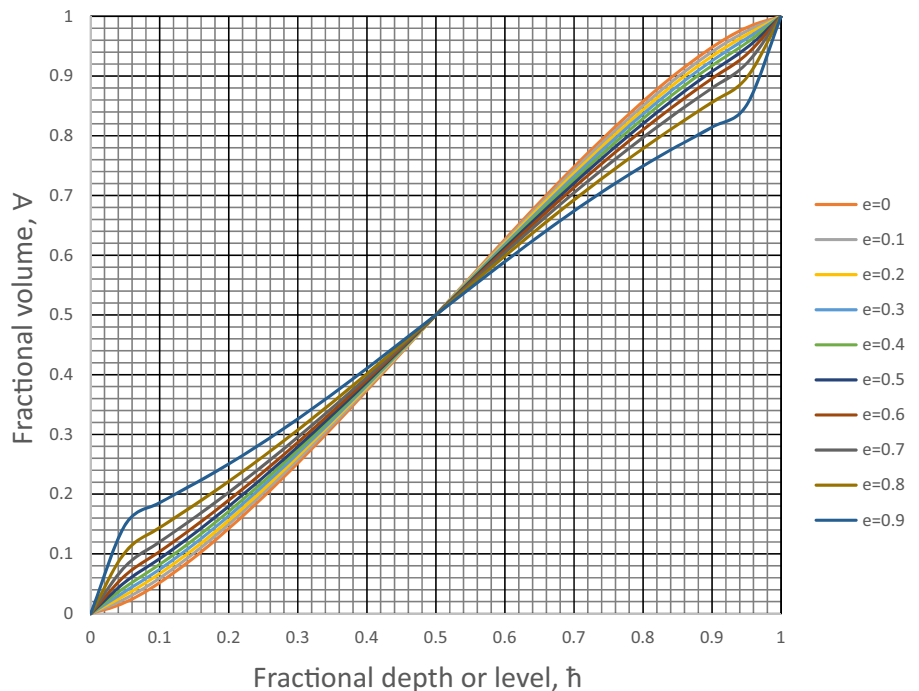

$$V = \frac{1}{\pi} \left[\cos^{-1} \left\{ \frac{1 - 2\bar{h}}{\sqrt{\left[\frac{4e^2}{1-e^2}\right] [\bar{h} - \bar{h}^2] + 1}} \right\} - 2(1 - 2\bar{h}) \cdot \sqrt{\bar{h} - \bar{h}^2} \right] \quad (36)$$

$$V = \frac{1}{\pi} \left[\sin^{-1} \left\{ \frac{\sqrt{\left(\frac{4}{1-e^2}\right) (\bar{h} - \bar{h}^2)}}{\sqrt{\left[\frac{4e^2}{1-e^2}\right] [\bar{h} - \bar{h}^2] + 1}} \right\} - 2(1 - 2\bar{h}) \cdot \sqrt{\bar{h} - \bar{h}^2} \right] \quad (37)$$

$$V = \frac{1}{\pi} \left[\tan^{-1} \left\{ \frac{\sqrt{\left(\frac{4}{1-e^2}\right) (\bar{h} - \bar{h}^2)}}{1 - 2\bar{h}} \right\} - 2(1 - 2\bar{h}) \cdot \sqrt{\bar{h} - \bar{h}^2} \right] \quad (38)$$

Equations (36)–(38) were used to produce the chart in Fig. 5 which shows curves depicting the volume-level relationships for various elliptic horizontal cylinders with different eccentricities.

2.3.2. Circular Horizontal Cylinders

Next, we consider a horizontal cylinder of length L with circular cross-section of radius R partially filled with liquid to a depth of h . It should be observed that the circular horizontal cylinder is a special case of the elliptic horizontal cylinder with zero eccentricity ($e = 0$). For this case, $b = a = R$ (Fig. 3), and thus the equivalents of Eqs. (27) – (29) for the partially-filled volume are

$$V = R^2 L \left[\cos^{-1} \left\{ 1 - 2 \left(\frac{h}{2R} \right) \right\} - 4 \left(\frac{1}{2} - \frac{h}{2R} \right) \cdot \sqrt{\left(\frac{h}{2R} \right) - \left(\frac{h}{2R} \right)^2} \right] \quad (39)$$

$$V = R^2 L \left[\sin^{-1} \left\{ 2 \sqrt{\left(\frac{h}{2R} \right) - \left(\frac{h}{2R} \right)^2} \right\} - 4 \left(\frac{1}{2} - \frac{h}{2R} \right) \cdot \sqrt{\left(\frac{h}{2R} \right) - \left(\frac{h}{2R} \right)^2} \right] \quad (40)$$

$$V = R^2 L \left[\tan^{-1} \left\{ \frac{2 \sqrt{\left(\frac{h}{2R} \right) - \left(\frac{h}{2R} \right)^2}}{1 - 2 \left(\frac{h}{2R} \right)} \right\} - 4 \left(\frac{1}{2} - \frac{h}{2R} \right) \cdot \sqrt{\left(\frac{h}{2R} \right) - \left(\frac{h}{2R} \right)^2} \right] \quad (41)$$

where $0 \leq h \leq 2R$

Likewise, the fractional volume for the circular horizontal cylinder follows from Eqs. (36)–(38) in which we set $e = 0$.

$$V = \frac{1}{\pi} \left[\cos^{-1} \{ 1 - 2\bar{h} \} - 2(1 - 2\bar{h}) \cdot \sqrt{\bar{h} - \bar{h}^2} \right] \quad (42)$$

$$V = \frac{1}{\pi} \left[\sin^{-1} \left\{ 2 \sqrt{(\bar{h} - \bar{h}^2)} \right\} - 2(1 - 2\bar{h}) \cdot \sqrt{\bar{h} - \bar{h}^2} \right] \quad (43)$$

$$V = \frac{1}{\pi} \left[\tan^{-1} \left\{ \frac{2 \sqrt{(\bar{h} - \bar{h}^2)}}{1 - 2\bar{h}} \right\} - 2(1 - 2\bar{h}) \cdot \sqrt{\bar{h} - \bar{h}^2} \right] \quad (44)$$

where the fractional depth in this case is

$$\bar{h} = \frac{h}{2R}$$

The chart of Fig. 6 with $e = 0$ depicts the Eqs. (42)–(44) for the circular horizontal cylinder.

2.3.3. Trapezoidal Horizontal Cylinders

In some instances, especially in open-channel flows, one may encounter vessels or channels with trapezoidal cross-section. Consider Fig. 7 showing a horizontal vessel or channel with length L and maximum depth H partially filled with liquid to a depth of h but with a trapezium as its cross-section. The parallel sides of the trapezium are of length B and b as shown in the figure.

The volume of liquid obtained as the product of the area of the trapezium traced out by the occupying liquid and the vessel length is

$$V = \frac{1}{2} [(h \cot \alpha_1 + b + h \cot \alpha_2) + b] h \cdot L \quad (45)$$

$$V = \frac{1}{2} h L [h (\cot \alpha_1 + \cot \alpha_2) + 2b] \quad (46)$$

The vessel geometry reveals that

$$H \cot \alpha_1 + b + H \cot \alpha_2 = B \quad (47)$$

From (47), it follows that

$$\cot \alpha_1 + \cot \alpha_2 = \frac{B - b}{H} \quad (48)$$

So, Eq. (46) becomes

$$V = \frac{1}{2} h L \left[(B - b) \frac{h}{H} + 2b \right] \quad (49)$$

As with other geometries, we obtain the dimensionless fractional volume by dividing Eq. (49) by the maximum volume of the vessel given by Eq. (50).

$$V_{\max} = \frac{1}{2} H L (B + b) \quad (50)$$

Such that,

$$V = \frac{V}{V_{\max}} = \frac{\frac{h}{H} [(B - b) \frac{h}{H} + 2b]}{B + b} \quad (51)$$

Or

Fig. 6 Volume-level relationship for the partially-filled horizontal cylinder with circular cross-section

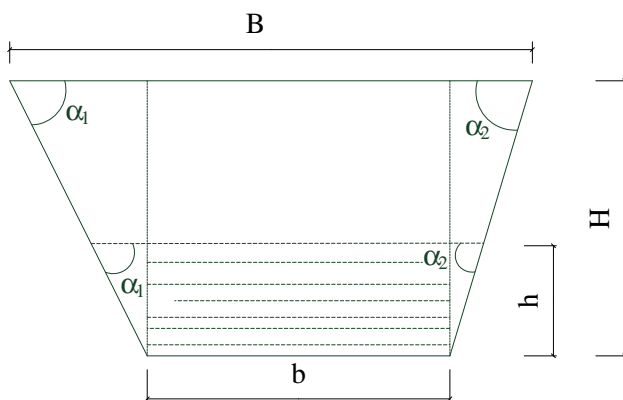
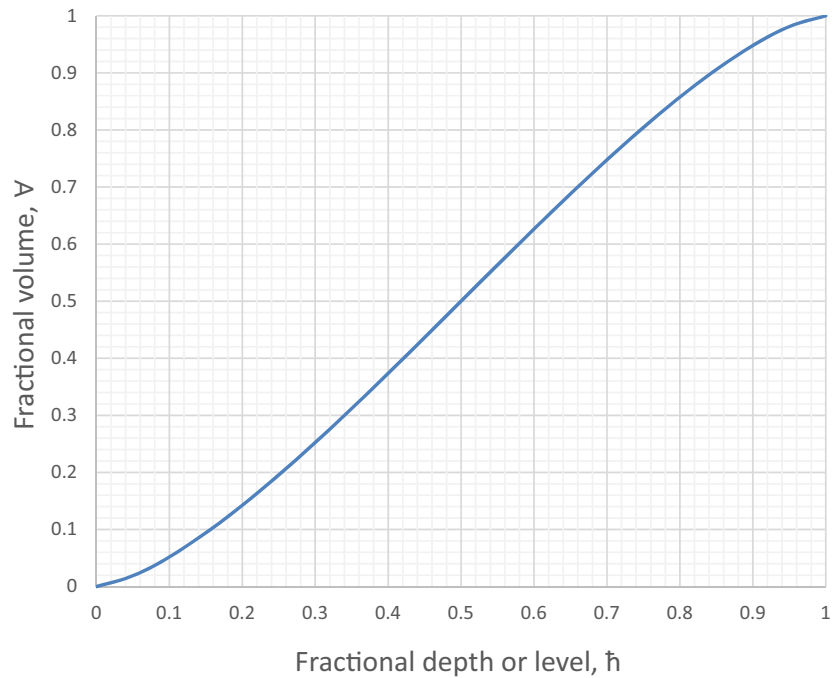

Fig. 7 The partially-filled trapezoidal horizontal cylinder

$$V = \frac{(1 - k)\bar{h}^2 + 2k\bar{h}}{1 + k} \tag{52}$$

where k is a dimensionless fractional geometric parameter relating the two parallel sides of the vessel and is defined as follows

$$k = \frac{b}{B}, 0 < k < 1 \tag{53}$$

And \bar{h} retains its usual meaning as the fractional depth of liquid in the vessel defined as

$$\bar{h} = \frac{h}{H}$$

Figure 8 graphs Eq. (52) for the trapezoidal vessel at different values of the geometrical parameter k .

2.3.4. Cuboidal Vessels

Cuboidal tanks are very common and partially-filled tank volume calculations are very easy to determine for this geometry. For completeness' sake, it has been included in this work, mainly because it is a limiting case of the trapezoidal tank considered in the last section. When $b = B$, the trapezoidal horizontal cylinder (Fig. 7) becomes a cuboid, as such we can estimate the partially-filled volume from Eq. (49) thus:

$$V = hLb \tag{54}$$

Likewise, the fractional volume of the partially-filled cuboidal tank can be calculated from Eq. (52) with $k = 1$. Thus, we obtain that, for the cuboidal tank,

$$V = \bar{h} \tag{55}$$

which is a simple linear relationship.

2.3.5. Triangular Horizontal Vessels

A rather uncommon geometry, though possible (as an open channel or vessel), is the horizontal cylinder with triangular cross-section. Again, this is a limiting case of the trapezoidal horizontal cylinder (Fig. 7) with $b = 0$. The partially-filled liquid volume can be estimated from Eq. (49) thus:

Fig. 8 Volume-level relationships for the trapezoidal horizontal cylinder at different fractional geometric parameter, k

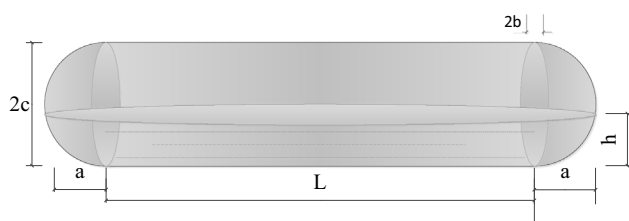
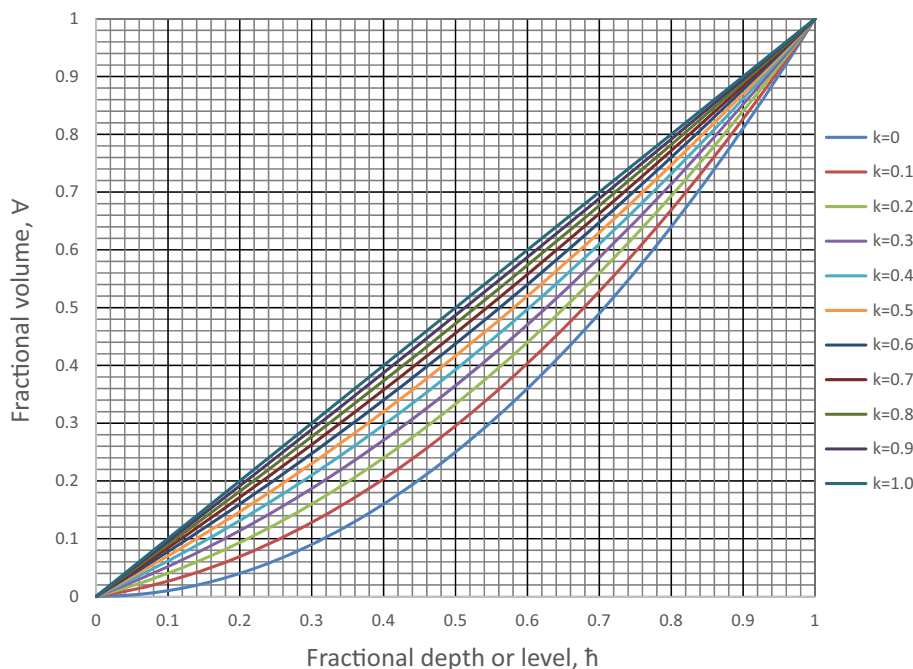

Fig. 9 Partially-filled elliptic horizontal cylinder with hemi-ellipsoidal ends

$$V = \frac{1}{2}hL \left[B \frac{h}{H} \right] \tag{56}$$

The fractional volume follows from Eq. (52) as a limiting case when $k = 0$. Thus, we have

$$\forall = \bar{h}^2 \tag{57}$$

2.4. Composite Horizontal Cylinders

In Sect. 2.3, we analyzed the flat-end horizontal cylinders. However, in most process applications, we often encounter vessels with composite geometries especially the horizontal cylinder with other shapes at its ends. This section is given to the analysis of these types of horizontal cylinders.

2.4.1. Elliptic Horizontal Cylinders with Hemi-Ellipsoidal Ends

Figure 9 shows an elliptic horizontal cylinder with hemi-ellipsoids at its two ends. The composite cylinder is of total length $L + 2a$ comprising a cylindrical part of length L (whose cross section is an ellipse of major axis $2c$ and minor axis $2b$) and two hemi-ellipsoidal parts with axes $2a$, $2b$ and $2c$.

The partially-filled volume of the vessel can be obtained by Eq. (58) which is a combination of the volume of a partially-filled ellipsoid (Sect. 2.1) and that of a horizontal elliptic cylinder (Sect. 2.3.1).

$$V = \frac{\pi ab}{3c^2} h^2 (3c - h) + bcL \left[\cos^{-1} \left\{ \frac{\frac{1}{2} - \frac{h}{2c}}{\sqrt{\left[\left(\frac{b}{c} \right)^2 - 1 \right] \left[\left(\frac{h}{2c} \right) - \left(\frac{h}{2c} \right)^2 \right] + \frac{1}{4}}} \right\} - 4 \left(\frac{1}{2} - \frac{h}{2c} \right) \cdot \sqrt{\left(\frac{h}{2c} \right) - \left(\frac{h}{2c} \right)^2} \right] \text{ where } 0 \leq h \leq 2c \tag{58}$$

At full capacity, the volume of the vessel is given by Eq. (59)

$$V_{\max} = \frac{4\pi abc}{3} + \pi bcL \quad (59)$$

The fractional volume is therefore obtained by dividing Eq. (58) by Eq. (59) and defining the fractional depth as

$$\bar{h} = \frac{h}{2c}$$

$$V = \frac{\pi}{3}h^2(3R-h) + R^2L \left[\cos^{-1} \left\{ 1 - 2 \cdot \frac{h}{2R} \right\} - 2 \left(1 - 2 \cdot \frac{h}{2R} \right) \cdot \sqrt{\left(\frac{h}{2R}\right) - \left(\frac{h}{2R}\right)^2} \right] \text{ where } 0 \leq h \leq 2R \quad (64)$$

$$\forall = \frac{V}{V_{\max}} = \frac{\frac{4}{3} \cdot \frac{2a}{L} \cdot \bar{h}^2 \left(\frac{3}{2} - \bar{h}\right) + \frac{1}{\pi} \left[\cos^{-1} \left\{ \frac{\frac{1}{2} - \bar{h}}{\sqrt{\left[\left(\frac{b}{c}\right)^2 - 1\right] [\bar{h} - \bar{h}^2] + \frac{1}{4}}} \right\} - 4 \left(\frac{1}{2} - \bar{h}\right) \cdot \sqrt{\bar{h} - \bar{h}^2} \right]}{\frac{2}{3} \cdot \frac{2a}{L} + 1} \quad (60)$$

If we define the following dimensionless geometric parameters for the composite horizontal cylinder

$$k = \frac{2a}{L + 2a}, 0 < k < 1 \quad (61)$$

and the eccentricity e for the elliptic horizontal cylinder part

$$e^2 = 1 - \frac{b^2}{c^2}, 0 < e < 1 \text{ for } c > b > 0 \quad (62)$$

The fractional volume for the composite becomes

And the full-capacity volume is

$$V_{\max} = \frac{4\pi R^3}{3} + \pi R^2L \quad (65)$$

The fractional volume is therefore obtained by

$$\forall = \frac{2k\bar{h}^2(3 - 2\bar{h}) + \frac{3}{\pi}(1 - k) \left[\cos^{-1} \{ 1 - 2\bar{h} \} - 2(1 - 2\bar{h}) \cdot \sqrt{\bar{h} - \bar{h}^2} \right]}{3 - k} \quad (66)$$

where in this case, the dimensionless geometric parameter k is defined as

$$\forall = \frac{2k \cdot \bar{h}^2(3 - 2\bar{h}) + \frac{3}{\pi}(1 - k) \left[\cos^{-1} \left\{ \frac{1 - 2\bar{h}}{\sqrt{\left[\frac{4e^2}{1 - e^2}\right] [\bar{h} - \bar{h}^2] + 1}} \right\} - 2(1 - 2\bar{h}) \cdot \sqrt{\bar{h} - \bar{h}^2} \right]}{3 - k} \quad (63)$$

2.4.2. Horizontal Cylinders with Hemispherical Ends

Another common composite is the truly horizontal cylinder (of circular cross-section) with hemispherical ends. This composite is a special case of the elliptic horizontal cylinder with hemi-ellipsoidal ends considered in Sect. 2.4.1. For this special case, $2a = 2b = 2c = 2R$ where R is the radius of the horizontal cylinder and its hemispherical ends. The partially-filled volume is defined as

$$k = \frac{2R}{L + 2R} \quad (67)$$

And the fractional depth

$$\bar{h} = \frac{h}{2R} \quad (68)$$

Equation (66) is graphed in Fig. 10 which shows, for various values of k , the relationship between the fractional level of liquid in the partially-filled horizontal cylinder with hemispherical ends and the fractional volume. It can be observed that when $k = 0$, we have a limiting case of a horizontal cylinder with flat ends while for $k = 1$, we have

Fig. 10 Volume-level relationships for partially-filled horizontal cylinder with hemispherical ends at different values of the dimensionless geometric parameter, k

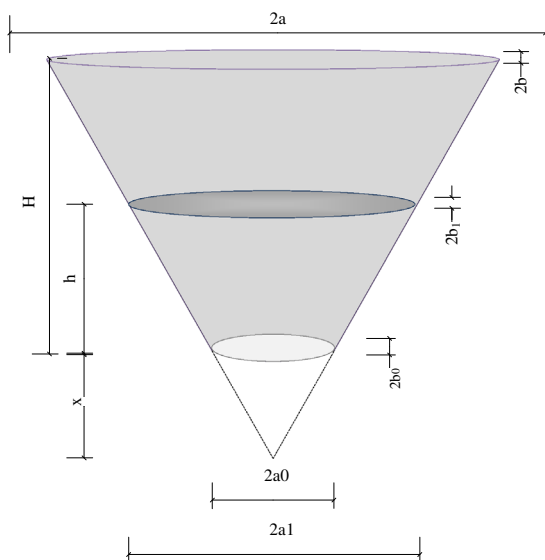
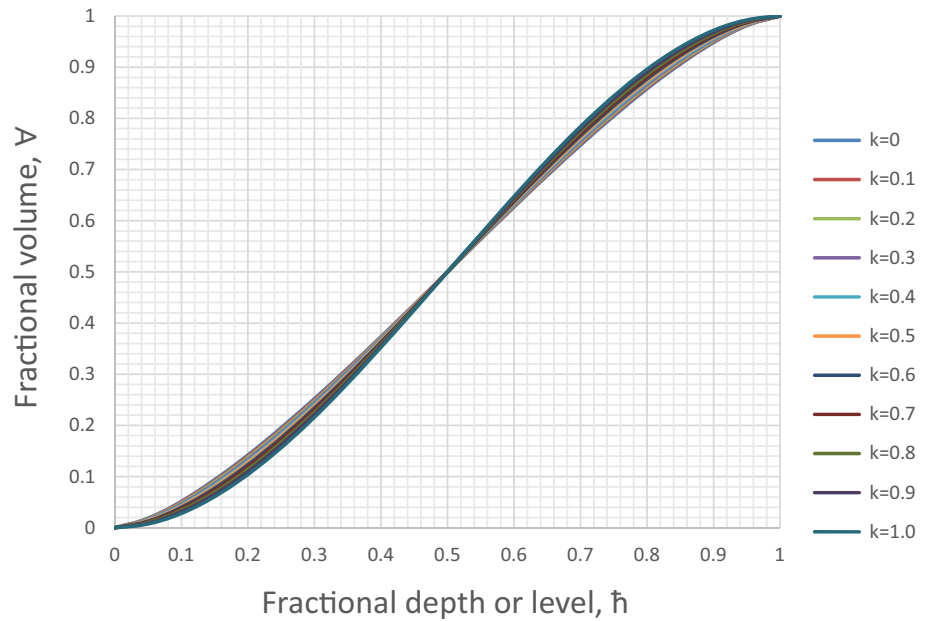

Fig. 11 Partially-filled conical vessel (frustum of a cone) with elliptic cross-section

a spherical vessel without the horizontal cylinder part (i.e. $L = 0$).

2.5. Conical Vessels

To obtain volume-level relationships for vessels of this category, a truncated elliptic cone (Fig. 11) would be considered to give a quite general picture of conical vessels from which others may be derived. The vessel of height H is a frustum of an inverted cone partially-filled with liquid to a depth of h . The base of the vessel is an ellipse of axes $2a_0$ and $2b_0$ while the top is an ellipse of axes $2a$ and $2b$.

Fig. 12 Semi-axes of the elliptic surfaces of the conical vessel showing similar triangles

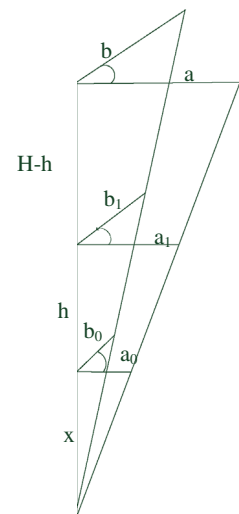

The volume of the liquid in the vessel is

$$V = \frac{1}{3} \pi a_1 b_1 (h + x) - \frac{1}{3} \pi a_0 b_0 x \tag{69}$$

where x is the height of the cut-off cone.

It can be observed that the three elliptic surfaces involved in Fig. 11 are similar; and in order to establish the expression for this observed similarity, Fig. 12 which shows the semi-axes (major and minor) of the elliptic surfaces along the vessel height, becomes helpful. From it, these basic expressions can be written (similar triangles) from which other useful relationships may be derived.

$$\frac{a_0}{x} = \frac{a_1}{h + x} = \frac{a}{H + x} \tag{70}$$

$$\frac{b_0}{x} = \frac{b_1}{h+x} = \frac{b}{H+x} \quad (71) \quad a_0 = b_0 = \frac{d_0}{2} \quad (83)$$

From Eqs. (70) and (71) respectively, we express x in terms of the known geometric parameters thus,

$$x = \frac{\frac{a_0}{a} H}{1 - \frac{a_0}{a}} \quad (72)$$

$$x = \frac{\frac{b_0}{b} H}{1 - \frac{b_0}{b}} \quad (73)$$

which establish that

$$\frac{a_0}{a} = \frac{b_0}{b} = k \quad (74)$$

So that

$$x = \frac{kH}{1-k} \quad (75)$$

From Eq. (70) and (71), we can deduce the relations for a_1 and b_1 in terms of the vessel's known geometric parameters:

$$a_1 = a \left[k + (1-k) \frac{h}{H} \right] \quad (76)$$

$$b_1 = b \left[k + (1-k) \frac{h}{H} \right] \quad (77)$$

Substituting Eqs. (74)–(77) in Eq. (69), we obtain

$$V = \frac{1}{3} \pi abH \left[k + (1-k) \frac{h}{H} \right]^2 \left[\frac{h}{H} + \frac{k}{1-k} \right] - \frac{1}{3} \pi abH \frac{k^3}{1-k} \quad (78)$$

which on expansion and simplification becomes:

$$V = \frac{1}{3} \pi abH \left\{ (1-k)^2 \left(\frac{h}{H} \right)^3 + 3k(1-k) \left(\frac{h}{H} \right)^2 + 3k^2 \left(\frac{h}{H} \right) \right\} \quad (79)$$

The maximum capacity of the vessel,

$$V_{\max} = \frac{1}{3} \pi abH \left\{ (1-k)^2 + 3k(1-k) + 3k^2 \right\} \quad (80)$$

or

$$V_{\max} = \frac{1}{3} \pi abH \{ k^2 + k + 1 \} \quad (81)$$

The fractional volume is therefore

$$\forall = \frac{(1-k)^2 \bar{h}^3 + 3k(1-k) \bar{h}^2 + 3k^2 \bar{h}}{k^2 + k + 1} \quad (82)$$

where k (defined by Eq. (74)) is the ratio of either of the major or minor axis of the elliptic base to that of the top.

For a circular cone, however,

$$a = b = \frac{D}{2} \quad (84)$$

So that

$$k = \frac{d_0}{D} \quad (85)$$

which is the ratio of the diameters or radii of the base and top of the circular truncated cone.

While Eq. (82) for the fractional volume still remains valid for this, the volume and maximum volume are respectively:

$$V = \frac{1}{12} \pi D^2 H \left\{ (1-k)^2 \left(\frac{h}{H} \right)^3 + 3k(1-k) \left(\frac{h}{H} \right)^2 + 3k^2 \left(\frac{h}{H} \right) \right\} \quad (86)$$

$$V_{\max} = \frac{1}{12} \pi D^2 H \{ k^2 + k + 1 \} \quad (87)$$

For truly conical process tanks for which $d_0 = 0$, $k = 0$

$$V = \frac{1}{12} \pi D^2 H \left(\frac{h}{H} \right)^3 \quad (88)$$

$$V_{\max} = \frac{1}{12} \pi D^2 H \quad (89)$$

$$\forall = \bar{h}^3 \quad (90)$$

Equation (82) shows the relationship between the fractional volume and fractional level for a partially-filled conical vessel at different values of the dimensionless geometric parameter k .

3. Conclusions

This paper sets out to develop a useful theoretical tool which can assist process engineers with the task of calibrating process tanks. The paper presents a mathematical analysis of common geometries and composites and develops equations and charts which could be used to estimate tank volumes from given depth of liquid. A normalization technique was used in the mathematical analyses of the partially-filled process vessels such that fractional volume and fractional depth were introduced as key variables in addition to dimensionless geometric parameters which take values between 0 and 1. This technique enables the study of process vessels in general. The fractional volume when multiplied by 100 ($100 \times \forall$) expresses what percentage of the full capacity of the tank, the liquid holds. Similarly, the fractional depth, when multiplied by 100 ($100 \times \bar{h}$), can give the wetted depth of the tank as a percentage of full height or depth of the tank; or simply, the liquid level in the tank as a percentage of the

full level. The advantage of using fractional volume and depth is that irrespective of the size of the vessel, the volume and depth of liquid can be determined for the tank geometry of interest using the dimensionless geometrical parameters. When the actual volume and depth are required however, they can be obtained by simply multiplying the fractional volume (\forall) and fractional depth (\bar{h}) by the maximum volume (V_{\max}) and maximum height (H) respectively.

Another possible use of the derived volume-level relationships is in the design of process tanks. The equations and charts can be used to answer design questions such as: “What depth of liquid in a horizontal cylindrical tank would correspond to a 75% liquid capacity?”; “What geometrical dimensions are required to give a liquid level holdup of 80%?” and so on.

Furthermore, the characteristic geometrical parameters of the vessel take care of the vessel’s uniqueness, size and shape. Hence, the fractional volume-level charts and equations also lend itself to usage for scale-up procedures. A vessel can be studied at a small scale or size as a model to a large-scale prototype design; the dimensionless geometrical parameters of the small vessel will be the same as that of the large vessel to be constructed, allowing calibration studies to be conducted on the small model and then scaled-up for the actual larger design of the prototype.

Besides aiding in design studies, these derived volume-level relationships will also prove to be very useful as they can be input or programmed into level measuring devices used in calibrating process tanks to calculate or estimate liquid volume for a measured depth without further experimentation.

In conclusion, there are enormous potential uses and applications of the geometrical calibration equations and charts put forward in this paper for different geometrical shapes of process tanks for which the reading engineer and allied practitioners can adopt and adapt the volume-level relationships in their daily practice.

References

- [1] S. Kurwadkar, S.S. Sethi, P. Mishra and B. Ambade, Unregulated discharge of wastewater in the Mahanadi River Basin: risk evaluation due to occurrence of polycyclic aromatic hydrocarbon in surface water and sediments. *Marine Pollution Bulletin*, 179 (2022) 113686.
- [2] B. Ambade, S.S. Sethi, S. Kurwadkar, A. Kumar and T.K. Sankar, Toxicity and health risk assessment of polycyclic aromatic hydrocarbons in surface water, sediments and groundwater vulnerability in Damodar River Basin. *Groundwater for Sustainable Development*, 13 (2021) 100553.
- [3] M.F. Hasan, M. Nur-E-Alam, M.A. Salam, H. Rahman, S.C. Paul, A.E. Rak, B. Ambade and A.R.M. Towfiqul Islam, Health risk and water quality assessment of surface water in an urban river of Bangladesh. *Sustainability*, 13(12) (2021) 6832.
- [4] J. Howell, Towards the re-verification of process tank calibrations. *Transactions of the Institute of Measurement and Control*, 31(2) (2009) 117–128.
- [5] M. Knyva, V. Knyva, Z. Nakutis, V. Dumbrava and M. Sauroris, A concept of fuel tank calibration process automation within IoT infrastructure. *MAPAN-J. Metrol. Soc. India*, 32(1) (2017) 7–15.
- [6] O.O. Agboola, P.P. Ikubanni, R.A. Ibikunle, A.A. Adediran and B.T. Ogunsemi, Generation of calibration charts for horizontal petroleum storage tanks using microsoft excel. *MAPAN-J. Metrol. Soc. India*, 32(4) (2017) 321–327.
- [7] O.O. Agboola and P.P. Ikubanni, Application of statistical quality control (SQC) in the calibration of oil storage tanks. *Journal of Production Engineering*, 20(1) (2017) 128–132.
- [8] Yeandle, M. (2012): Calibration of storage tanks, Class #2070, Troy, Ohio
- [9] O.O. Agboola, B.O. Akinnuli, B. Kareem and M.A. Akintunde, Decision on the selection of the best height-diameter ratio for the optimal design of 13,000 m³ oil storage tank. *Cogent Engineering*, 7 (2020) 1770913.
- [10] V. Knyva, M. Knyva and J. Rainys, New approach to calibration of vertical fuel tank. *Journal of Elektronical Ir Elektrotechnika*, 19(8) (2013) 1–6.
- [11] API 2555 Standard, Liquid calibration of tanks. Measurement Coordination Department, Washington, D.C. (2014).

Publisher’s Note Springer Nature remains neutral with regard to jurisdictional claims in published maps and institutional affiliations.

Springer Nature or its licensor (e.g. a society or other partner) holds exclusive rights to this article under a publishing agreement with the author(s) or other rightsholder(s); author self-archiving of the accepted manuscript version of this article is solely governed by the terms of such publishing agreement and applicable law.