

University of Groningen

Pulmonary

de Boer, Anne; Hagedoorn, Paul; Grasmeyer, Floris

Published in:
 Practical Pharmaceutics

DOI:
[10.1007/978-3-031-20298-8_14](https://doi.org/10.1007/978-3-031-20298-8_14)

IMPORTANT NOTE: You are advised to consult the publisher's version (publisher's PDF) if you wish to cite from it. Please check the document version below.

Document Version
 Publisher's PDF, also known as Version of record

Publication date:
 2023

[Link to publication in University of Groningen/UMCG research database](#)

Citation for published version (APA):

de Boer, A., Hagedoorn, P., & Grasmeyer, F. (2023). Pulmonary. In P. Le Brun, S. Crauste-Manciet, I. Krämer, J. Smith, & H. Woerdenbag (Eds.), *Practical Pharmaceutics: An International Guideline for the Preparation, Care and Use of Medicinal Products, Second Edition* (pp. 299-335). Springer International Publishing AG. https://doi.org/10.1007/978-3-031-20298-8_14

Copyright

Other than for strictly personal use, it is not permitted to download or to forward/distribute the text or part of it without the consent of the author(s) and/or copyright holder(s), unless the work is under an open content license (like Creative Commons).

The publication may also be distributed here under the terms of Article 25fa of the Dutch Copyright Act, indicated by the "Taverne" license. More information can be found on the University of Groningen website: <https://www.rug.nl/library/open-access/self-archiving-pure/taverne-amendment>.

Take-down policy

If you believe that this document breaches copyright please contact us providing details, and we will remove access to the work immediately and investigate your claim.

Downloaded from the University of Groningen/UMCG research database (Pure): <http://www.rug.nl/research/portal>. For technical reasons the number of authors shown on this cover page is limited to 10 maximum.



Contents

14.1	General Introduction	301
14.1.1	Aerosol Characterisation	301
14.1.2	Particle Deposition Mechanisms and Efficiency	302
14.2	Metered Dose Inhalers	303
14.2.1	General Introduction	303
14.2.2	MDI Design Variations	304
14.2.3	Special MDI Designs, Add-On Devices for MDIs and Developments	306
14.2.4	Practical Notes on the Use of MDIs	309
14.3	Dry Powder Inhalers	310
14.3.1	General Introduction	310
14.3.2	Basic DPI Concept and Working Principle	310
14.4	Nebulizers	318
14.4.1	Ultrasonic Nebulizers	319
14.4.2	Jet Nebulizers	320
14.4.3	Vibrating Mesh Nebulizers	322
14.4.4	Soft Mist Inhaler Respimat	323
14.4.5	New Developments and Add-On Devices	323
14.4.6	Drug Solutions, Suspensions and Excipients for Nebulization	323
14.4.7	Maintenance and Cleaning of Nebulizers	324
14.5	New Developments and Some Future Expectations	324
14.6	Inhaler Performance, Choice, Instruction and Error Use	325
14.6.1	General Introduction	325
14.6.2	Inhaler Performance	325
14.6.3	Inhaler Choice	326
14.6.4	Inhaler and Inhalation Errors and Instruction	327
	References	330

Abstract

For adequate pulmonary drug therapy, choosing the appropriate type of inhaler is just as important as selecting the right type of drug. This chapter on pulmonary drug delivery devices provides the background knowledge that is required for making a suitable inhaler choice and giving a proper instruction for its adequate use. Different types of inhalers may be available for the same type of drug and the prescriber has to ascertain that the requirements for correct operation match the cognitive, inspiratory and mechanical skills of the patient. To make a good choice and give the correct instructions for use, the instructor therefore has to know the working principle of various pulmonary drug delivery devices, understand the mechanisms that govern aerosol deposition in the respiratory tract, be able to interpret different aerosol characterisation definitions correctly and know how to operate selected devices best for an optimal therapy. This chapter aims to familiarize instructors with this complex matter.

What Is New?

The first edition of Practical Pharmaceutics presented the reader an elaborate list of definitions and terms used in pulmonary drug therapy to enable the correct interpretation of aerosol characteristics and understanding of the mechanisms of drug deposition in the respiratory tract with different aerosol generation devices. It also gave a brief introduction into the principles of operation of various types of drug delivery systems. This second edition provides the basic background knowledge that is required for choosing the most suitable inhaler system for a particular drug therapy application and for giving a proper instruction about how to best operate and maintain the inhaler system.

Learning objectives

Instructors of pulmonary drug delivery systems have to know and understand:

- Which variables govern the drug deposition of aerosols from inhalers in the human respiratory tract,
- How these variables can be controlled, or influenced, to optimise drug distribution in the respiratory tract,

A. de Boer · P. Hagedoorn
Department of Pharmaceutical Technology and Biopharmacy,
University of Groningen, Groningen, the Netherlands
e-mail: a.h.de.boer@rug.nl; p.hagedoorn@rug.nl

F. Grasmeijer (✉)
Department of Pharmaceutical Technology and Biopharmacy,
University of Groningen, Groningen, the Netherlands

PureIMS B.V., Roden, the Netherlands
e-mail: fgrasmeijer@pureims.com; f.grasmeijer@rug.nl

- How to interpret literature data regarding inhaler performance correctly,
- How inhalers operate and which variables influence their performance,
- Which respiratory, cognitive, visual and motor skills are required to operate inhalers correctly,
- How to instruct and motivate users of inhalers best and which type of drug delivery system is most suitable for obtaining good adherence to the therapy and compliance with the instructions for use.

Orientation

Drug delivery systems are designed to administer the correct amount of active ingredient to the patient in the desired manner. They either have to achieve a local or a systemic effect, release the active substance instantaneously and fast, slowly and prolonged, or time, place and amount controlled, all depending on the active substance formulation and the required therapeutic effect. To adequately reach the site of action, medicines may be developed for different routes of entry and to achieve the desired release profile, they must have the correct chemical and physical properties. Additionally, drug delivery systems need to provide sufficient stability and protect the active ingredient from external influences, such as light, oxygen and moisture if it is sensitive to their exposure. To fulfil all these requirements, formulation of the active ingredient into the delivery system can be complex and require the use of various excipients and multiple formulation steps. It also can include the production of semi-finished products with specific properties that contribute to the desired overall performance of the final product. Although the manufacturing processes of many drug delivery systems are rather multiplex, their use by the patient must be simple.

The intended performance should be inherent in their design and preparation method, and preferably the patient does not have to acquire knowledge of their precise working principle. Simple instructions such as when, and how often to take the medication, how to store it, and what to avoid (e.g., breaking enteric coated tablets or capsules) should be sufficient to meet the requisites for correct administration.

Inhalation systems are an aberrant category of drug delivery systems in different ways. They exist in great variety and can be distinguished into nebuliser systems, metered dose inhalers (MDIs) and dry powder inhalers (DPIs), see Fig. 14.1.

In contrast to most other active substance preparations, their performance and, by that, the efficacy of the therapy depends strongly on how they are operated by the patient. They have to deliver a active substance aerosol with the appropriate aerodynamic particle size distribution and in the correct amount with the most suitable inhalation mode to the lungs, which is an organ that evolved highly successfully to reject inhaled matter. Only within confined limits for the size distribution of the aerosol and the entire inhalation manoeuvre, sufficient active substance deposition at the desired site of action is possible. Already minor deviations from these narrow limits shift drug deposition in the lungs away from optimal. In addition to that, nearly all DPIs are breath controlled. This means that the patient's breath delivers the energy for powder uptake from the dose compartment and dispersion into fine enough particles. Therefore, the success of the aerosol generation process from these inhalers depends on the patient's inhalation manoeuvre too. Only nebuliser systems and metered dose inhalers (MDIs) derive the energy for aerosolization of the active substance from external sources. The working principles and performances of these three categories of inhalers are the subject of this chapter.

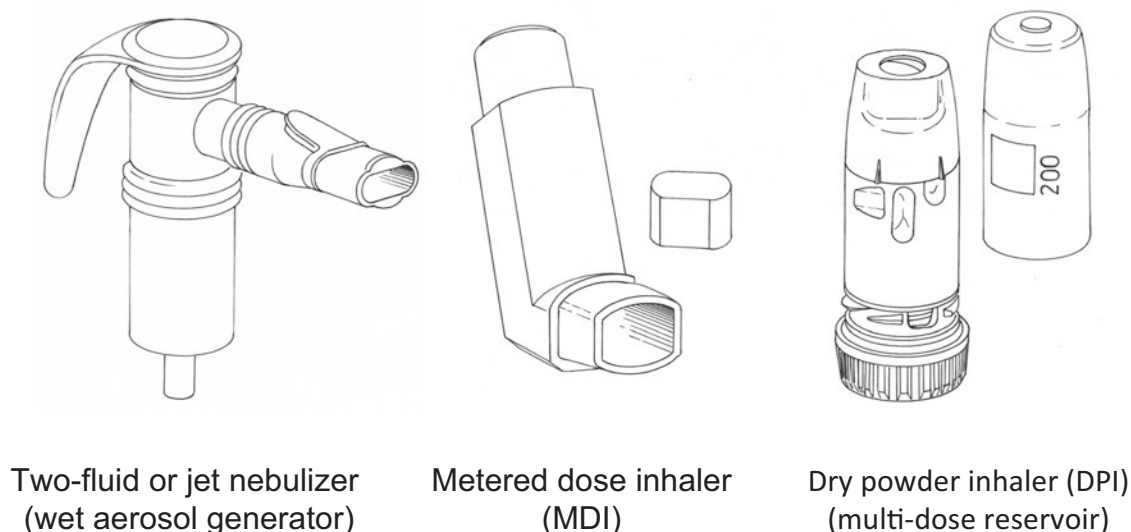

Fig. 14.1 Examples from the three main categories of inhalation devices: nebulizers, metered dose inhalers (MDIs) and dry powder inhalers (DPIs). Only MDIs and DPIs are portable devices

14.1 General Introduction

14.1.1 Aerosol Characterisation

For comparative performance evaluation and choosing the most appropriate type of inhaler for the individual patient, the properties of the delivered aerosol are a valuable tool and its aerodynamic size distribution is the leading parameter.

Aerosol particles can be dry or wet (droplets) and have different diameters. Aqueous droplets usually have a spherical shape and unit density (1 g/cm^3). However, when they are dry, they can have different shapes, densities and also different surface properties. These differences in size, shape and density render particles different aerodynamic behaviours, as the forces acting on airborne particles, which are primarily the force of gravity and the drag force when the particles move relatively to the surrounding air, depend on these properties. Different shapes also make it impossible to characterise the particles with a single dimension (e.g., diameter), whereas particles of the same size, but different densities, have different masses. To normalise the aerodynamic behaviour of particles with different geometric properties, various equivalent diameters have been introduced, including the equivalent volume diameter (D_E), Stokes diameter (D_S) and aerodynamic diameter (D_A). Their definitions and relationships are presented by Hinds [1], but for the understanding of aerosol behaviour, it is enough to know that particles with the same aerodynamic diameter behave aerodynamically exactly the same, irrespective of their (differences in) geometric size, shape or density. They experience the same drag force in an air stream and also have the same settling velocity in still air.

Aerodynamic particle size distributions of medical aerosols are usually measured with cascade impactors under well-defined conditions. There are different cascade impactors in use, having different stage numbers and cut-off values for these stages (Fig. 14.2). This may be an error source when comparing unprocessed data from different impactors with each other. Aerodynamic size distributions are mostly presented as the cumulative mass distribution of the aerosol as function of the aerodynamic diameter. Such mass distributions include a lot of information, including the mass fraction within the most favourable size distribution for lung deposition and the mass median aerodynamic diameter (MMAD). The MMAD is the diameter splitting the aerosol mass in two equal parts: half the mass is in particles larger than the MMAD and half the mass is in smaller particles.

The most favourable size distribution for lung deposition depends on many factors of which the inhaled flow rate (which determines the particle velocity) and particle residence time in the lungs are the most relevant. Usually the size fraction $1\text{--}5 \mu\text{m}$ is considered optimal for whole lung deposition, whereas the narrow size fraction $1\text{--}3 \mu\text{m}$ is more appropriate for targeting the small airways. When the mass fractions within these size ranges are presented as percentage of the dose, referred to as fine particle fractions (FPFs), a choice can be made from the labelled dose (label claim) or the delivered dose. For many new inhalers, the label claim and delivered dose are more or less the same, on the understanding that the label claim is a fixed value, whereas the delivered dose can vary due to variable conditions of inhaler use. For older inhalers, the label claim equals the metered dose, which is higher than the delivered dose as a result of active substance residues in the inhalation device after inhalation. For an appropriate comparison of fine particle fractions these differences in definition have to be considered.

Because aerodynamic size distributions require graphic presentation for comparison, aerosols are frequently compared on the basis of their MMADs, which are single numbers. It is believed that when the MMAD of a particular aerosol lies within the aforementioned size ranges, the inhaler that produced this aerosol is suitable for inhalation. This is a persistent misconception however. First of all, the MMAD does not give any information about the mass fraction of the dose that it represents (e.g., the metered or delivered dose). Secondly, the span of the size fraction for which MMAD was computed is often not mentioned in literature. Therefore, it can have been for the entire aerosol or only for a small size fraction of that aerosol, meaning that an unknown mass fraction of the aerosol can lie outside the most favourable size range. Using an MMAD without considering additional information can have various consequences, as shown in Fig. 14.3. For instance, precisely the same mass fraction within the size fraction $1\text{--}5 \mu\text{m}$ can have MMADs that differ considerably from each other (by a factor 4 for the extremes in Fig. 14.3a). This can have the consequence that the aerosol represented by curve III (MMAD is $4 \mu\text{m}$) is rejected, whereas it is equally suitable as both other aerosols represented by curves I (MMAD is $1 \mu\text{m}$) and II (MMAD is $2 \mu\text{m}$). On the other hand, aerosols having exactly the same MMAD can represent completely different size distributions of which the bimodal aerosol in Fig. 14.3b (curve III) contains almost zero mass fraction of particles between 1 and $5 \mu\text{m}$. This, in contrast with the aerosol of curve I of which nearly the entire mass is within the size fraction $1\text{--}5 \mu\text{m}$. Thirdly, the most optimum MMAD depends on the inhalation manoeuvre as will be explained in the next paragraph.

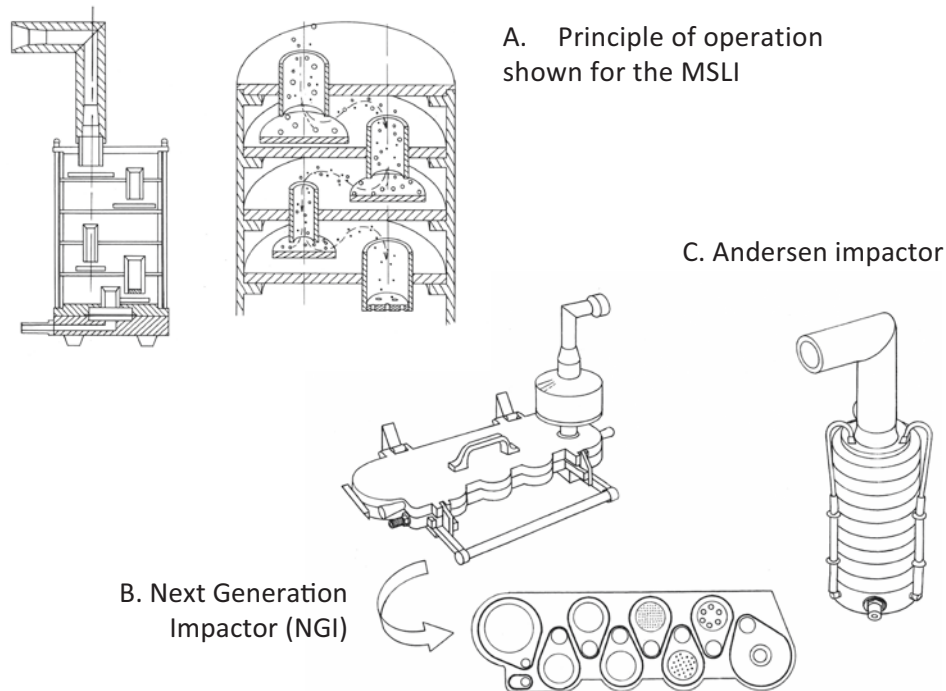

Fig. 14.2 The principle of cascade impactor analysis, shown for the multi-stage liquid impinger (MSLI: **a**) the flat Next Generation Impactor (NGI: **b**) and the stacked (cylindrical) Andersen impactor (**c**)

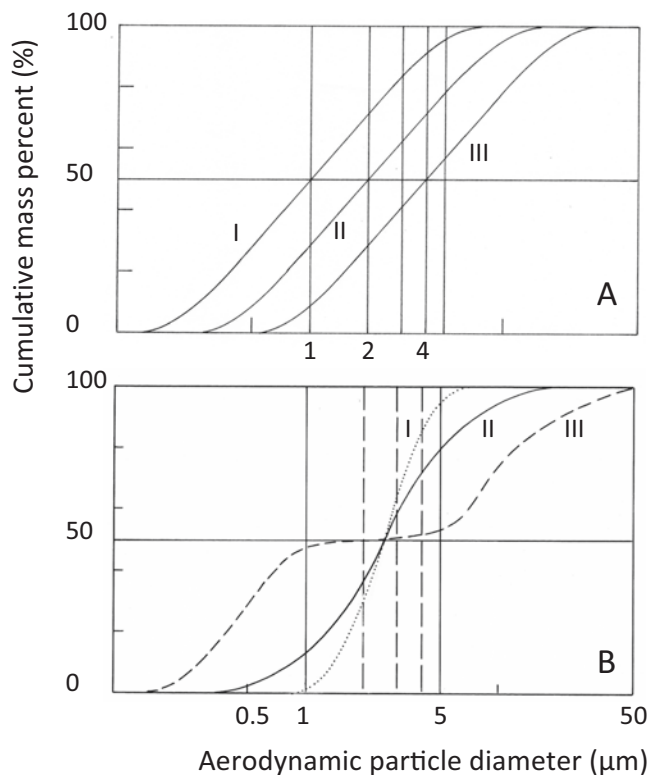

Fig. 14.3 (a) Three aerosols with precisely the same fine particle mass fractions (FPF 1–5 μm), but different MMADs of 1, 2 and 4 μm for the aerosol respectively. (b) Three aerosols with precisely the same MMAD, but completely different size distributions and FPFs. Note that the examples I to III given in the fig. A are different from the examples I to III in fig. B. There is no relationship between the examples in both figures

14.1.2 Particle Deposition Mechanisms and Efficiency

Particles entering the human respiratory tract with the inhaled air stream are subjected to different forces. It is the drag force of the air that transports the particles through the dichotomously branching system of air ducts in which the airway diameters decrease, and their numbers increase from the trachea to the alveoli. This combination of changes causes the velocity to become initially higher in the first three airway generations beyond which it gradually diminishes until it is almost zero in the gas exchange region. In this tortuous system of airway ducts, the air and particles have to change their direction at each point of bifurcation. For particles travelling too fast, as in the larger airways, or being too heavy, as for the largest particles, it may be impossible to follow the streamlines of the air. Such particles with a high inertia may, therefore, collide with the airway wall.

When the air with the aerosol particles travels deeper into the respiratory tract, and most of the largest particles have been removed by inertial deposition, the air velocity decreases. This causes sedimentation by the force of gravity to become the dominant deposition mechanism. Particles reach a stationary settling velocity after equilibrium is obtained between the force of gravity and the (Stokes) drag force of the air through which they fall. Similar as inertial deposition, the likelihood of making contact with an airway wall for a particle by sedimentation

Deposition by inertial impaction can be predicted with the impaction parameter ($IP = \rho \cdot D \cdot U^2$), in which ρ is the particle density, D is the particle diameter and U its velocity. Obviously, a particle's likelihood of impaction with an object also depends on its distance to that object and for the fraction of aerosol deposited in the human oropharynx as function of the IP, indicative correlations can be found in the work of DeHaan and Finlay [2, 3]. They used the flow rate (Φ) instead of the particle velocity (U) for computation of the IP, which introduces variation when inhalers with different mouth-piece diameters are used, as they result in different air velocities in the oral cavity at the same flow rate.

depends on multiple variables, including the particle mass and its residence time in the lower airways. The settling velocity decreases exponentially when the particle diameter becomes smaller and is only approximately 0.035 mm/s for particles with an aerodynamic diameter of 1 μm [1]. This means that it takes nearly 6 s for such particles to fall half the distance of the diameter (0.4 mm) of a horizontal alveolar duct. Hence, the distance to the wall is a determinant for the success of particle deposition by sedimentation too. For an aerosol of monodisperse 1 μm particles distributed evenly over the diameter of the alveolar duct, it would theoretically result in 50% deposition when their residence time is 6 s. For particles in a non-horizontal duct, this percentage may be considerably lower and the same is true for particles smaller than 1 μm . To make sedimentation deposition in the lower airways possible, not only their residence time on-site is important. Equally important is getting them there, which requires a deep exhalation to residual volume prior to inhalation, as this makes convective particle transport into the lower airways possible. Following the inhalation, holding the breath during at least 5 s is to be recommended in order to increase the drug fraction deposited by sedimentation.

Submicron particles, particularly when they have diameters smaller than 0.1 μm can stay in the air much longer and are usually exhaled again. They can be displaced randomly by Brownian motion when the air stands still however. This may bring them in contact with the airway walls too. The efficiency of total lung deposition decreases with declining particle diameter from 100% for particles of 5–6 μm and larger at flow rates >60 L/min, and reaches a minimum value of about 20% for particles of 0.5 μm . Increasing the flow rate shifts deposition to larger airways, particularly towards the oropharynx and mouth.

14.2 Metered Dose Inhalers

14.2.1 General Introduction

MDIs have the advantage of being small. Yet they contain many single active substance doses. They are also relatively cheap and easy and convenient to use, at least compared to nebulizers. These advantages seem to explain why they are widely prescribed for the treatment of asthma and COPD. However, MDIs are also inefficient in active substance delivery to the lungs compared to well-designed DPIs and vibrating mesh nebulizers, although this is largely due to patient errors, and, therefore, partly avoidable. Their concept may seem simple, but it has many complicated technical aspects related to various ways of abuse to avoid for the users. MDIs are also harmful to the environment with the emission of propellant into the air. Currently used hydro fluoroalkane (HFA) propellants are strong greenhouse gases. HFA-227 has a global warming potential (GWP) of 3220 (relative to CO_2 on a 100-year horizon) versus 1430 for HFA-134a [4, 5]. Also, the atmospheric lifetimes are rather long being 14.6 and 36.5 years for HFA-134a and HFA-227 respectively, whereas HFAs, unlike CO_2 , are not removable from the atmosphere with the natural carbon cycle. They already replaced previously used chlorofluorocarbons (CFCs) that contributed to the decomposition of the ozone layer and the necessity of a new propellant transition has meanwhile been accepted. New devices based on hydrofluorocarbon 152a are expected to reach the market in 2025. The environmental burden may be an aspect to consider when prescribing inhalation medication, but this consideration must be done while taking its significance and possible consequences for the therapy in mind. The estimated HFA-impact from MDIs on global warming differs for various studies between 0.1% and 0.5%.

Metered dose inhalers (MDIs) are spray cans for liquid active substance formulations. They have metering chambers with separate inlet and outlet valves from the canister and to the patient, respectively. The metering chamber, which is within the canister, has the volume needed for the separation of a single drug dose from the bulk solution or suspension in the canister (Fig. 14.4). The active substance is dissolved or suspended in a propellant, or a mixture of different propellants, with or without a co-solvent, which is mostly ethanol. The

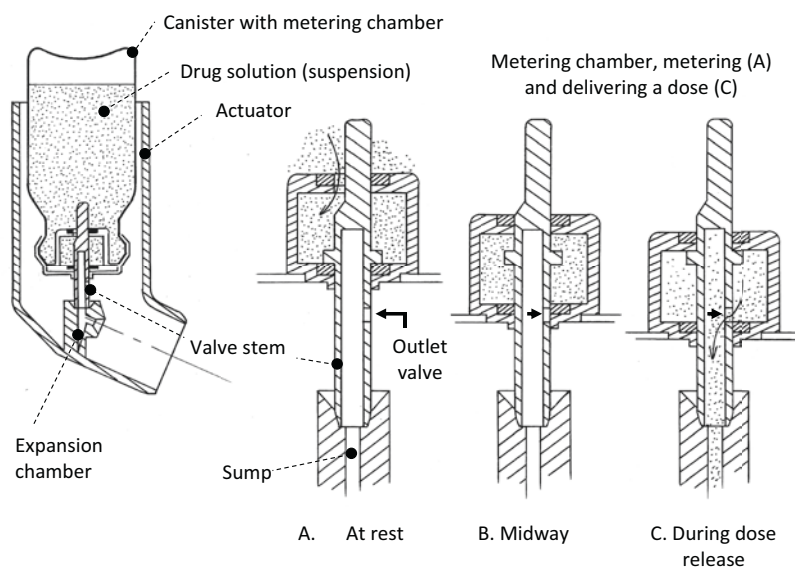

Fig. 14.4 Working principle of a metered dose inhaler (MDI) having a canister (bulk reservoir) with the drug solution (suspension), a metering chamber and an actuator (housing, with a release channel, having a small expansion chamber, for the drug solution). The three positions of the metering valve show how the metering chamber corresponds with

the bulk reservoir in the resting position (a) and with the aerosol release channel during dose activation (c). Midway (b), both openings are closed to prevent delivery of an excess dose from the canister via the metering chamber directly into the valve stem

high vapour pressure of the propellant (mixture) keeps the canister under a constant (though temperature-dependent) pressure for as long as there is liquid in the tank. This pressure is the driving force for filling of the metering chamber from the canister and emptying of the chamber into the air (depending on which passageway for the fluid is opened). Upon release of the metered amount of drug solution or suspension from the metering chamber through its outlet valve and via the valve stem into the inhaled air stream, the propellant rapidly evaporates which creates high internal shear forces in the liquid. These disrupt the liquid into small droplets which constitute the inhaled drug aerosol. The volume metered for a single dose varies between 25 and 100 μL .

14.2.2 MDI Design Variations

Although all MDIs more or less have the same appearance (shape and size), there may be several invisible differences that can significantly affect their performance and/or influence the operation procedures. Patients need not know all the technical details of MDI design, but they should be made aware of certain risks and possible consequences of incorrect handling procedures when using an MDI. MDIs containing HFA-134a were the first to appear on the market (around 1996) and the introduction of HFA-227 followed in 2006. HFA-227 has a lower vapour pressure and it is primarily used to lower that of HFA-134a (Table 14.1). Advances in valve technology have made this rather unnecessary however. HFA-227 can also be

desired in the formulation to improve active substance solubility of hydrophobic active substances. Ethanol, which has a much lower vapour pressure, almost by a factor 10 compared to HFA-134a, is alternatively frequently used as co-solvent. In 2020 approximately 75% of total inhaler sales in the USA concerned HFA-134a devices. This high percentage is favourable from an environmental viewpoint considering the difference in GWP and lifetime with HFA-227. In addition to the propellant or propellant mixture various excipients may be used to improve MDI performance and obtain a good solubility and stability of the active substance formulation. Next to ethanol, they include bulking, wetting, solubilisation, flavouring and buffering agents, active substance stabilisers (antioxi-

Table 14.1 Physical properties of the HFA propellants (Solkane) 134a and 227, and ethanol at 20 °C

Property	Dimension	HFA-134a	HFA-227	Ethanol
Vapour pressure	kPa	579	395	5.95
Surface tension (σ)	mN/m	8.69	6.96	22.39
Boiling temperature	°C	-26.3	-16.5	+78.4
Density of the liquid (ρ)	Kg/m ³	1226	1408	789.2
Dynamic viscosity (η)	mPa.s	0.211	0.267	1.144

Data for HFA-134a and HFA-227 from the manufacturer of Solkanes [5]

dants), emulsifiers, valve lubricants and acidity and/or tonicity adjustment agents [4]. They all can have an influence on the aerosolization process and, thus, on the particle size distribution of the aerosol, as has for instance been shown for the co-solvent ethanol on the *in vitro* deposition of beclomethasone dipropionate aerosol from a HFA-134a MDI [6].

One of the most fundamental differences is that between active substance solution and suspension MDIs. Aerosols from solution or suspension may differ significantly from each other, not only regarding the particle size distribution, but also with respect to active substance content and other physico-chemical properties. Active substance solutions are unlikely to separate, but suspensions may be unstable, particularly when the particle density differs from that of the liquid [4]. The densities of HFA-134a (1.226 g/cm³) and HFA-227 (1.385) at room temperature (25 °C) are within the range of densities for crystalline organic materials, but even a small difference with the suspended active substance may cause particles to rise through the liquid or sink to the bottom when the MDI is left to rest. These particle-liquid separation effects are referred to as creaming and sedimentation (or settling), respectively. Particle-liquid separation by either of these processes leaves supernatant liquid without active substance, or an enriched liquid layer with active substance to meter and administer (Fig. 14.5a, b), which may result in under- or overdosing, respectively. Separated suspensions may be homogenised again by violently shaking the canister and this needs to be done prior to every use [7]. Omitting to shake the canister not only affects the first of subsequent inhaled doses, but also all following doses. Each shot containing too much active substance (in case of sedimentation) leaves less active substance for the following shots, whereas

each shot of pure supernatant (in case of creaming) potentially increases the active substance concentration in following metered volumes. Restored homogeneity is often short-lived. Therefore, as part of the instruction procedure not only the shaking of a suspension MDI prior to use as such has to be mentioned, but also the precise procedure, including the inhalation has to be explained. Particularly the relevance of minimising the time between shaking and inhalation has to be emphasised. Recently, the effects of a delay between shaking the MDI and firing a dose on the delivered active substance amount were investigated for a number of different suspensions MDIs [8]. They reported that even a relatively short time span of 60 s between shaking and dose firing resulted in a 320% increase in delivered dose for Flovent HFA, a 346% increase for Ventolin Evohaler and a 230% increase in Airomir Inhaler versus a 75% decrease for budesonide and a 76% decrease for formoterol from the Symbicort MDI. Only QVAR100 remained constant in their study. Comparable results (deviations in delivered dose between 30% and 380% relative to the label claim for fixed dose combination MDIs) over the same time span for the delay between shaking and dose firing were presented by Chierici et al. [7].

The position of the metering chamber is at the top of the canister, but the canister is placed upside down in the actuator (Fig. 14.4). This makes certain that the inlet opening in the valve stem towards the metering chamber is in the liquid phase and not in the gas phase. This secures filling of the metering chamber with liquid instead of with vapour, at least until the labelled number of doses has been taken from the canister. Correct re-filling of the metering chamber is an important reason for not using an MDI upside down when taking a dose. In its most simple design a metering valve

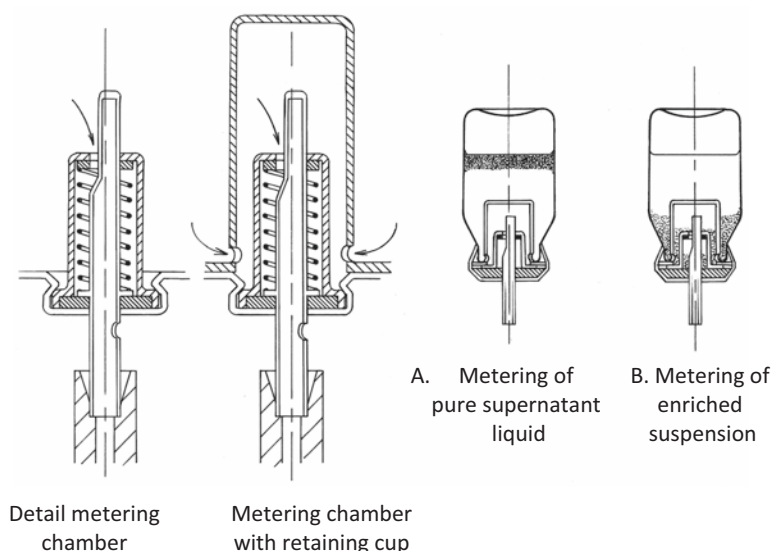

Fig. 14.5 The difference between a metering chamber without (left) and with (right) retaining cup (see text). The figure also shows how pure supernatant liquid (a) or an enriched suspension (b) can be metered due to creaming or sedimentation of the suspension respectively

consists of a small (lock) chamber, having the appropriate volume, and a hollow valve stem. The valve stem is the actual (double) valve, that connects either the metering chamber with the liquid in the canister, or the metering chamber with the actuator nozzle in the mouthpiece of the inhaler housing. At rest (Fig. 14.4a), the connection with the canister is made to fill the metering chamber with liquid under the pressure of the propellant vapour. To fire a dose, the container has to be pressed against a spring load (see Fig. 14.5) in order to re-position the valve stem, which is blocked by the sump, relative to the metering chamber [9]. This creates the outlet for the propellant formulation that is discharged via an expansion chamber and through a capillary (atomising nozzle) into the mouthpiece channel (Fig. 14.4c).

Poor consistency of delivered dose at the end of the inhaler's lifetime can be the consequence of taking more doses from the MDI than labelled [10]. Most MDIs are not designed to cease delivering after the last labelled dose has been taken and frequently contain noticeably still active substance formulation after running out of labelled doses. This invites patients to continue using the device which may end in 'tailing off' without being noticed. The tail off characteristics depend very much on the position of the valve inlet, showing either a steep decrease in delivered drug dose, or an extremely poor consistency of delivered drug dose for the surplus doses delivered.

'Loss of prime' is an additional mechanism for dose reduction [11]. This phenomenon refers to liquid drainage from the metering chamber into the canister through the small orifice (capillary) that connects both compartments with each other. After a dose has been taken, MDIs are usually treated with complete disregard for the position in which the MDI is held. This could be vertical (top, or bottom up), reclining at different angles, or horizontal. MDIs are put down somewhere or carried around in pockets and handbags. This can result in a stable position when MDIs lie down, or a continuously changing position when they are carried around. For a significant part of total time this position will be different from that during inhalation when the canister is upside down with the inlet capillary to the metering chamber below the liquid level. When the capillary has a position above the liquid in the canister, a liquid-vapour interface is created that has a high capillary force to retain the liquid in the metering chamber in all positions. The capillary force is a function of the orifice diameter, the surface tension and contact angle and de-stabilisation of the liquid-vapour interface can result in a liquid flow from the metering chamber. This can occur

when external forces, such as inertial forces and the force of gravity, exceed the capillary force, as from dropping the MDI.

Loss of prime is the main reason why MDIs have to be primed before first use (preferably three times, thereby wasting the doses), as transport and storage may be responsible for draining out liquid from the metering chamber. Many patients may also keep different MDIs with the same medicine in different places, e.g., at home and in the office, to be used alternatively. Therefore, some devices may remain unused for a considerable time and/or be exposed to several temperature fluctuations. This also makes loss of prime possible. To reduce this risk, many currently marketed MDIs have a retaining cup, which envelops the metering chamber and holds part of the bulk liquid from the canister (Fig. 14.5). The function of the retaining cup is to prevent formulation from 'draining out' of the metering chamber when the MDI is stored in a way that would bring the inlet capillary of this chamber in contact with the vapour phase without this cup [9]. The cup has an inlet near the top of the canister which enables filling when the MDI is held in the position to inhale a dose, even when the amount of liquid in the canister is low. When the MDI is subsequently turned back with the metering valve up, the inlet capillary of the metering chamber is still submerged under liquid to prevent draining out. In addition, the position of the inlet openings to the retaining cup minimises the risk of drainage from the cup by the force of gravity. Retaining cups also provide enhanced consistency of delivered dose when the MDI has almost delivered the labelled number of doses [9].

14.2.3 Special MDI Designs, Add-On Devices for MDIs and Developments

One of the most frequently mentioned error handlings with MDIs is the actuation not corresponding to inhalation [12]. Patients actuate before inhaling or actuate too late due to a poor 'hand-lung coordination'. To overcome this problem, so-called autohalers have been developed, e.g., the Airomir or QVAR Autohaler (TEVA). The working principle of an autohaler is basically the same as that of a standard MDI shown in Fig. 14.4. The difference is in the actuator (plastic housing) which has a vane in the mouthpiece tube connected to a rocking construction underneath the canister. Before inhaling from an Autohaler, a spring load has to be applied to the canister bottom by lifting a small lever attached to the plastic housing manually (Fig. 14.6). This does not yet cause the firing of a dose as the rocking construction attached to the vane in the mouthpiece prevents that the canister moves down. First when the patient inhales, the vane turns by the air stream and releases a catch that holds the rocking construc-

tion in position when there is no flow rate through the MDI. This causes the rocker to rotate and take a lower position which enables the canister to go down to release a dose. This way, good hand-lung coordination is not necessary and the breathing manoeuvre coordinates the dose release. The threshold air flow rate value for vane flapping can be adjusted to release the dose in the early phase of inhalation.

A different method to overcome the ‘hand-lung coordination’ problem is the use of so-called valved holding chambers (VHCs) into which a dose can be fired (Fig. 14.7). They exist also without a valve and are then named spacer devices which have no volume to store a dose. Spacers are merely an elongation of the mouthpiece cylinder and meant to reduce the velocity at which the aerosol enters the oral cavity. They do not eliminate the problem of poor hand-lung coordination and, therefore, their use is scarce nowadays. Like spacers, VHCs reduce the oropharyngeal deposition. This potentially increases the lung dose and decreases local corticosteroid-related side effects [13]. VHCs are also applicable when a patient is unable to understand or execute the correct inhalation manoeuvre, as is the case with small (pre-school) children. The patient inhales the aerosol from the VHC during normal breathing or approximately 30 L/min at highest. In order to avoid excessive flow rates, many VHCs produce an audible signal to inform the patient that the inspiration effort is too high and this signal is used by healthcare trainers to teach patients the correct inhalation manner through a VHC. VHCs have a one-way valve in the mouthpiece section that opens only during inhalation in order to avoid that the aerosol is blown from the chamber through the inlet opening around the MDI mouthpiece during exhalation. VHCs exist in many different sizes and shapes and have been made of different construction materials.

Although they are meant to increase the amount of active substance available for lung deposition, much aerosol is lost due to inertial impaction (from the high plume velocity), sedimentation and electrostatic attraction by the inner inhaler VHC walls. VHC shape, construction material and volume are relevant in this respect, but their influence may depend on the type of MDI used. This results in inconsistencies in literature regarding potentially meaningful differences between different VHCs [14]. Nevertheless, each pairing of an MDI and VHC is a unique delivery system [13], and various in vitro studies have shown that clinical equivalence may not be expected when changing the VHC.

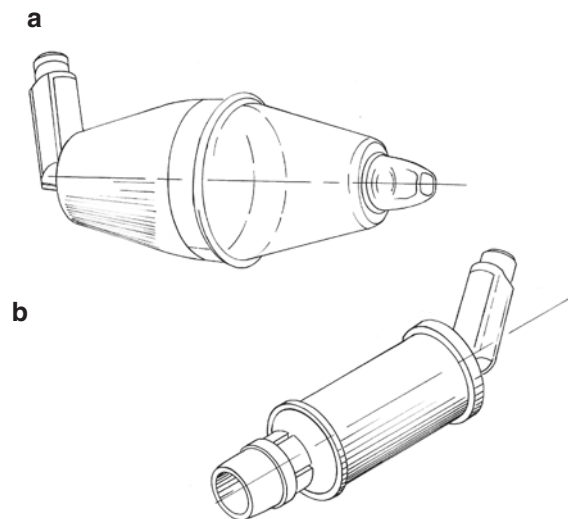

Fig. 14.7 Examples of valved holding chambers (VHCs). VHCs exist in different sizes and shapes and are constructed of different materials (with and without anti- electrostatic coating) (a) Large volume plastic VHC, e.g. Volumatic (GSK), 29.5 (Length) X 17 cm (width) (b) Small antistatic VHC, e.g. AeroChamber Plus Flow-Vu (Trudell Medical), 14.5 (length) X 4.5 cm (width)

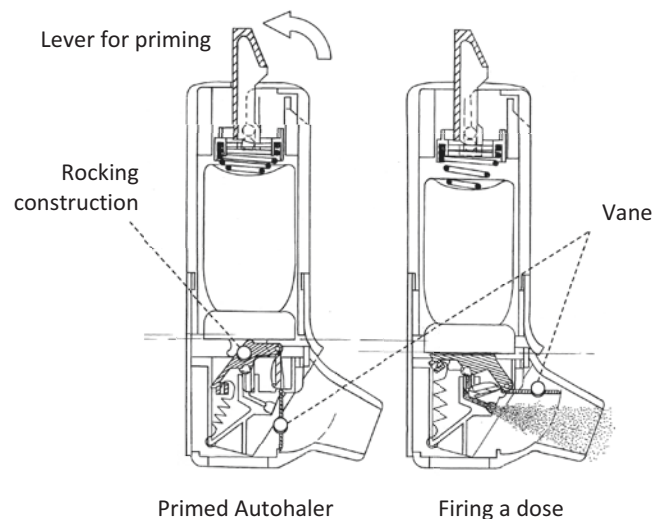

Fig. 14.6 The working principle of a breath-actuated MDI (Autohaler)

To reduce losses by electrostatic attraction of non-coated plastic VHCs somewhat, priming by firing multiple doses into the chamber (without suction) may be considered [15], although this is a waste of medication. Also washing in a lukewarm aqueous dilution of detergent and subsequent drying (drip and dry) is often mentioned as a suitable technique to improve VHC output [14]. However, both techniques may be nullified by the necessity of intensive daily cleaning and disinfection of VHCs used by patients with recurrent pulmonary infections when these are the result of the VHC becoming colonised with respiratory pathogens [16]. There exist also anti-static VHCs (aVHCs) but their effect appears to be very limited in practice, as for instance shown by Dassanayake and Sugget [14]. Delivered doses from aVHCs also depend very strongly on the active substance formulation [17]. They showed a great inter-device variation for five aVHCs of different types, with delivered doses for salbutamol being only 15–35% of the MDI-dose and for beclomethasone being 30–70% of the MDI-dose. They furthermore reported that applying the drip and dry technique to aVHCs increases specifically the output from the worst performing concepts. This improves the interchangeability of aVHCs. Metal VHCs are less electrostatic and also known for being less frequently colonised with respiratory pathogens [16]. They are furthermore less sensitive to the influence of the relative humidity of the air regarding the losses due to electrostatic attraction [18]. There exist also collapsible disposable paperboard VHCs (e.g., LiteAire, Thayer Medical) that can be used over multiple doses and do not have the inconvenience of being too voluminous. No performance data for such VHCs are known however.

To further reduce losses in a VHC, the time between firing a dose and inhalation should be minimised. It has been shown that already a 5 s delay can cause a significant decrease in mass output from the VHC, depending on the combination, while the MMAD remains largely the same [18, 19]. Both studies agreed also upon a very small effect of the flow rate (up to approx. 30 L/min) on the mass output and the size distribution of the aerosol.

When a child is unable to breathe through the mouthpiece (e.g., nose breathers) or unwilling to cooperate, a face mask can be attached to the VHC (Fig. 14.16), although the use of face masks is associated with many problems and challenges as reviewed by Csonka et al. [20]. Particularly a tight fit to the face is important as a small leak can already reduce the output dose to zero [21, 22]. Masks are available in different sizes with different shapes and the best one to use may depend on the tidal volume of the child [23, 24], or the child's respiratory rate [24] and whether the child is breathing through the nose or mouth. Nose breathing may result in 50% lower dose (or less) compared to mouth breathing [25] and for infants and young children that are

unwilling to cooperate, the delivered lung dose from an MDI-VHC with face mask combination is almost zero [22, 25]. Therefore, as soon as a child can hold the mouthpiece of the VHC correctly, the use of a face mask should be omitted [20].

Various studies have confirmed that patients do not know the number of doses left in their MDI and continue to use it after the labelled content (number of doses) has been taken [26, 27]. Until recently, shaking the canister or float tests in water were frequently recommended to check whether there are still doses left. Full canisters would sink and empty canisters would float, but studies have shown that float characteristics are rather product-specific [28]. Flotation tests were also found to obstruct the valve stem in more than 25% of all cases and for these reasons, floatation tests should be advised against. A confusing factor is the necessity to fill a significant excess amount of formulation (20–30 doses) into the canister during manufacturing [9]. Due to the uncertainty patients tend to use the medication for up to twice its intended lifetime, often even still when no aerosol is visibly released [27], or they return their MDI to the pharmacist when it still contains a significant number of labelled doses. As a result of this malpractice patients may find their MDI empty during an asthma exacerbation and having to contact the emergency service. Adding a dose counter to the MDI can improve patient satisfaction with their inhaler dramatically up to nearly 100% [29]. A literature review on dose counters for rescue bronchodilators has been written by Connor and Buck [30].

Several developments are known that potentially improve the therapy with MDIs, or have already confirmed improved MDI performance or stability, and a better control on lung deposition. They include Modulite (Vectura Ltd), adapted by Chiesi Farmaceutici and a co-suspension technique (Pearl Therapeutics) acquired by AstraZeneca. Because these are formulation aspects that the patient or instructor need not know, they will not further be explained. Readers interested in these technologies are advised to read the publications of Ganderton et al. [31] and Dellamary et al. [32] for Modulite and co-suspension technique respectively. Future MDI developments are likely to be the introduction of novel propellants, such as isobutane and HFO propellants (members of a tetrafluoropropene family) in order to meet the urgent need to suppress global warming [4]. HFA-152a is considered promising too on the basis of its physical properties, but the toxicology of these compounds may put restrictions on their use for inhaled medication.

14.2.4 Practical Notes on the Use of MDIs

In spite of the fact that MDIs are cheap, small, convenient to carry around and simple to use, they suffer from several drawbacks and prescribers should be aware of the many possible types of misuse and abuse of MDIs. Add-on devices, like VHCs, are available to cancel out some of these drawbacks, but they also largely eliminate the portable character of an MDI whereas their effect for many MDI-VHC combinations is arguable. From an extensive systematic literature review on inhalation errors an overall error frequency of 87% was concluded for MDIs, meaning that 87% of all MDI users made at least one critical error [33]. This is significantly higher than the overall error frequency for DPIs (61%). Although a very high between-study heterogeneity makes conclusions from patient error studies generally rather arguable, such high percentages should nevertheless be a reason for concern about the efficiency of the therapy. The most often described error with MDIs in literature is poor hand-lung coordination [e.g., 34]. A high plume velocity and the cold Freon effect are markedly the greatest flaws of the MDI concept, although both depend on the atomiser design and differ considerably between the propellant formulations. The premature stopping of the inhalation procedure upon the chilling sensation at the back of the throat from the impact of a cold aerosol are the main reasons for incomplete drug delivery to the respiratory tract from MDIs. Minimum plume temperatures may vary as much as between -50 and $+20$ °C [35, 36]. Increasing the distance between the nozzle exit and the measuring point, and/or increasing the time between dose release and temperature measuring reduces the plume temperature differences substantially [36]. Already at a distance of 100 mm, or after 500 ms, cold plumes have a temperature above the freezing point and differences between propellant formulations are more or less levelled out. Substantial oropharyngeal deposition from MDIs may further be due to a high plume velocity. Velocities at a relatively short distance (30 mm) from the nozzle vary typically between 5 and 20 m/s (18 and 72 km/h), or higher [31] but the velocity decreases exponentially when the distance is increased [37]. Spacers and VHCs may provide a satisfactory solution for all these problems with MDIs, but they can decrease the dose available for inhalation also quite significantly. Relatively small mass fractions of ethanol also reduce the plume temperature and velocity, but generally also increase the particle size.

Shaking a suspension MDI prior to inhaling a dose is mandatory for a consistent dose delivery and because it is often not known by the patient whether the inhaler used is a solution or a suspension device, it has been recommended to shake all MDIs before taking a dose. This, however, may lead to loss of prime, particularly for MDIs without a retaining cup when the device is not held in the position as during cor-

rect inhalation and the capillary to the metering chamber is in the gas phase. Not complying with the given instruction to prevent loss of prime is a great concern for effective MDI therapy. Using an MDI in the correct position (as shown in Figs. 14.4 and 14.5) for all handling manoeuvres must be strongly advised. It is known that some patients use their MDI in reverse position (canister down), which prevents that the retaining cup, or metering chamber, is re-filled correctly after the dose has been taken. Also, a strong emphasis has to be put on the necessity to minimise the time between shaking and inhaling. Although the latter may seem theoretically less relevant considering the low settling velocity of single particles that have about the same density as the liquid in which they are dispersed, there is experimental proof that an effect on delivered dose may already be obtained from waiting only a few seconds [7, 8]. In their study, Chierici et al. [7] showed that a short delay of only 10–30 s between shaking and inhaling can substantially influence the delivered drug dose compared to taking the dose immediately. They also showed what a dramatic effect this can have on all residual doses in the canister up to the end of its lifetime, particularly when the delay is not one-off.

Environmental conditions have considerable influence on MDI stability, performance and drug delivery in many different ways. For instance, the oropharyngeal deposition depends on the spray impaction force which is a function of the vapour pressure of the propellant (mixture) [38] and the vapour pressure increases exponentially with the temperature [39]. Between 10 and 30 °C the vapour pressure of HFA-134a almost doubles from 420 to 780 kPa. The size distribution of the aerosol depends strongly on the relative humidity of the air, particularly for cold plumes. High mass fractions of water in the air result in transient condensation on the droplets and increase their diameter. The effect seems greater for suspension MDIs than for solution MDIs. Findings like these indicate that inhaling in warm and moist environments from an MDI, for instance in the bathroom, or outdoor on a sweltering day, may result in a reduced efficacy of the therapy. The only benefit from a high relative humidity may be expected from a reduction of the losses in a VHC. Depending on the formulation and the construction materials used for the canister and the metering chamber, temperature fluctuations may result in transient temperature differences between the liquid in the metering chamber and that in the canister, which results in a vapour pressure difference that is large enough to overcome the surface tension force of the liquid film closing the orifice of the metering chamber [40]. This can result in draining liquid through the orifice and a few temperature fluctuations as between outdoor temperature (5 °C) and indoor temperature (20 °C) may be sufficient for causing substantial drainage from the metering chamber. It has been shown that the threshold temperature difference depends on the propellant formulation.

For instance, the presence of co-solvent ethanol significantly increases this threshold value because of its much higher surface tension than the HFA propellants [41]. All these reasons seem to indicate that it is relevant to avoid MDI exposure to high temperature and temperature fluctuations as much as possible. Healthcare experts should at least warn against leaving an MDI in the car on very cold or hot sunny days, or exposing it to direct sunlight, even in small handbags lying on a table in the sun.

14.3 Dry Powder Inhalers

14.3.1 General Introduction

Nearly all currently marketed DPIs are passive inhalers, meaning that the inhaled air stream delivers the energy for the entrainment of the powder from the dose compartment and dispersion of the powder formulation into a suitable aerosol for inhalation. This may have consequences for the inhaler performance and the drug deposition in the lungs when the inhalation manoeuvre and inspiratory effort are not according to prescriptions. Therefore, the implementation of correct DPI operation procedures must be taught with emphasis on all relevant steps and checked on a regular basis

by the health care specialist, as it is of utmost importance. The following paragraphs describe the basic DPI concept with its functional parts and the design variations therein, and how they affect the mode of operation.

14.3.2 Basic DPI Concept and Working Principle

In spite of the existence of three different classes of DPIs, well designed devices should have the same four primary functional parts (Fig. 14.9):

- a suitable powder formulation for the active substance,
- a dose carrying or metering compartment,
- a dispersion principle for the powder, and
- a housing for these parts with a mouthpiece and a mechanism for dose activation.

Optionally, there may be secondary signalling functions for feedback about the inhalation performance and the number of doses left (or taken) to the patient.

Important functions of the DPI are:

- Delivering a consistent drug dose to the patient as a dry powder aerosol with the appropriate aerodynamic particle size distribution for deposition in the target area at the generated flow rate through the device,

The first DPI having success on the market and being an example for many DPIs of the same type to follow up to the present day, was the Spinhaler (Fisons) with cromolyn sodium in 1970 [42]. During a period of nearly 30 years following the introduction of the Spinhaler, remarkably few innovations were made, as can be concluded from the low number of patents filed up to and including 1995 [43]. Not before 1997, two new DPI types (Glaxo Diskus and Astra Turbuhaler)

were approved by the FDA and first since that moment, the DPI family has grown rapidly, involving a variety of different types, all to be divided into three categories: single dose (capsule and blister) DPIs, multiple unit-dose DPIs and multi-dose reservoir DPIs (Fig. 14.8). DPIs do not have the undesired properties, impediments and dose limitations of MDIs discussed and explained in the previous paragraph, but they have their own specific requirements for good performance.

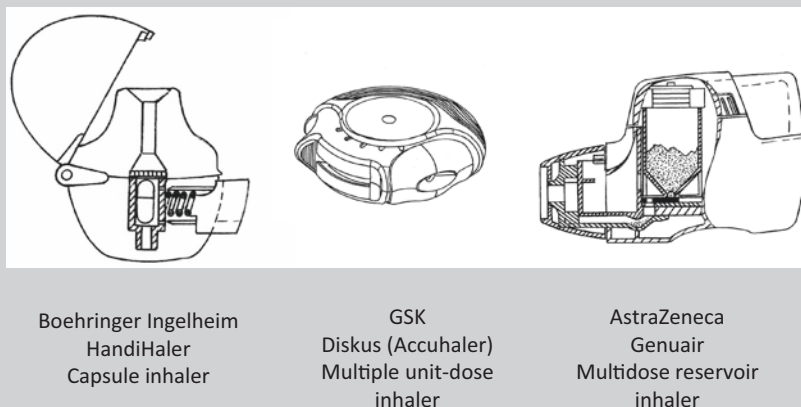

Boehringer Ingelheim
HandiHaler
Capsule inhaler

GSK
Diskus (Accuhaler)
Multiple unit-dose
inhaler

AstraZeneca
Genuair
Multidose reservoir
inhaler

Fig. 14.8 The three different categories of dry powder inhalers (DPIs)

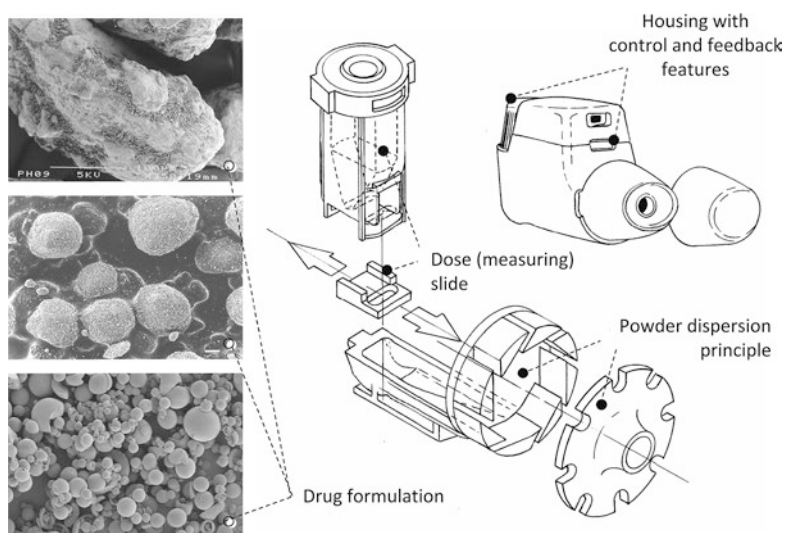

Fig. 14.9 The primary functional parts of a dry powder inhaler, including a powder formulation for the drug, a dose (measuring) system, a powder dispersion principle and a housing with control and signalling, and/or feedback functions as shown for the example of the Genuair multidose dry powder inhaler (AstraZeneca). For each of these parts different (design) solutions exist and the combination of parts may be

crucial to DPI performance. Particularly, the choice for the drug formulation, being either an adhesive mixture (top), soft spherical pellets (middle) or micronised (engineered) powder (bottom), has to be tuned with the dose (measuring) system and dispersion principle to assure consistency of delivered (fine particle) dose

- Delivering the aerosol preferably within the first 0.5–1 l of inhaled air for systemically acting medicines to facilitate active substance transport to the most distal airways, and
- Protecting the active substance formulation from environmental influences (air humidity, dust, light).

The DPI must furthermore be mechanically stable, have a simple and reliable dose activation mechanism, and preferably limit the range of achievable flow rates through the inhaler in order to minimise the oropharyngeal deposition. Operation must be as intuitive as possible and comprise not more than one or two simple mechanical handling steps in addition to the inhalation manoeuvre. The complexity of operation should be an important selection criterion when prescribing a DPI. Waste of powder must furthermore be prevented after the inhaler has been prepared or activated for inhalation and powder retention in the inhaler post inhalation should be as low as possible. The four primary parts will be addressed hereafter.

14.3.2.1 The Powder Formulation

Medicines for inhalation must be micronised to an aerodynamic size distribution that enables deposition in the target area. Particles for inhalation need to be in the very narrow size range from 1 to 5 micrometres, and for effective peripheral lung deposition preferably even between 1 and 3 μm (see Sect. 14.1). For the micronisation of the active substance, different techniques are available. They have been described before [e.g., 44] and are not the scope of this

chapter, but it needs to be realised that they can yield different physico-chemical properties that can cause differences in dispersion, stability and moisture sensitivity. Particles in the micron range are usually highly cohesive and adhesive and stick to each other as well as to all surfaces they make contact with [e.g., 1]. This means that they tend to form agglomerates that are too large for lung deposition. Most anti-asthma and COPD medicines are furthermore low-dose medicines in the microgram range, meaning that they cannot be metered accurately and reproducibly to the desired weight. They need to be processed with one or more inert excipient(s) for increasing the metered mass and preventing excessive losses to various inhaler parts, including the dose compartment of the DPI. The micronised active substances can either be mixed with the excipient(s) or be co-processed in a spray drying process. It is not necessary for the prescriber or user of DPIs to know details of these processes, but it must be known that this too yields different powders with different properties that reflect not only on their behaviour, but also on how to use and handle the DPI best.

Micronised active substances that are mixed with coarse crystalline excipients that have good flow properties of their own are referred to as adhesive mixtures [45], ordered mixtures [46], or interactive mixtures [47]. The history of this confusing nomenclature has been explained before [e.g., 48]. In many formulations, only one excipient is used, which for nearly all DPIs is alpha-lactose monohydrate in a size fraction that varies roughly between 10 and 200 micrometres. During the mixing process the active substance particles

need to be distributed over, and attached to the coarse excipient (carrier) particles in order to provide good homogeneity and sufficient physical stability of the blend. Multiple variables of the mixing process and of the blend constituents influence the properties of adhesive mixtures, which have to be fine-tuned to the type of DPI for which they are meant. They will not be discussed as they have been summarised before [e.g., 49]. The thus prepared composite active substance-excipient particles are too large for lung deposition and deposit in the oropharyngeal cavity where the active substance can cause adverse local side effects. The active substance particles need to be detached from the carrier surface during inhalation and to make this successful, high demands are made on the dispersion principle of the DPI. Usually, the largest active substance particles (including small coherent active substance or active substance-lactose agglomerates) are liberated from the carrier surface most easily, whereas the smallest particles remain attached to the carrier surface [50]. Therefore, the fineness of aerosols from adhesive mixtures increases with increasing energy input for dispersion (i.e. at higher flow rates) for well-designed DPIs up to a maximum, mostly achieved between 4 and 6 kPa (Fig. 14.10).

Adhesive mixtures, with the size distribution of the active substance obtained from micronisation, are typically used for the low dose medicines in the microgram range for asthma and COPD therapy. They include inhaled corticosteroids (ICSs), short and long acting beta agonists (SABAs and LABAs) and long acting muscarinic antagonists (LAMAs). All four drug categories are diluted with carrier lactose to powder dose weights varying from approximately 10–25 mg [51]. Around the millennium change also fixed-dose medicine combinations (FDCs) were introduced for the treatment of persisting asthma and severe COPD, which for the latter are typically LABA/LAMA combinations [e.g., 52]. For the treatment of asthma with persisting symptoms, ICS/LABA combinations, particularly fluticasone propionate/salmeterol xinafoate, have become the cornerstone [e.g., 53], but they are also used in COPD treatment. Fixed dose combination means either that the different medicines are in the same formulation, or both (or more) active substances are in different formulations that are inhaled simultaneously. For the latter solution, special inhalers are required, such as the GSK Ellipta that has two separate blister strips [54]. The strips are transported together and two blisters, each carrying a different drug formulation, are opened and emptied simultaneously. Operation is not different from that of the GSK Diskus. Most inhalers, however, carry single drug formulations with both drugs. It is not the scope of this chapter to dig deep into the preparation techniques used for FDC formulations for DPIs, which are mostly adhesive mixtures too, but it may require that the active substances are co-processed [e.g., 55] or that excipients are added to improve physical

stability and/or dispersion of the formulations. Corradi et al. [56] presented a DPI (NEXThaler) with extra-fine particles for the FDC of beclometason dipropionate and formoterol fumarate in an adhesive mixture formulation. To obtain sufficient separation of carrier and active substance particles from each other during inhalation, magnesium stearate as ‘force control agent’ has been formulated with the active substance and the carrier lactose. Force control agents

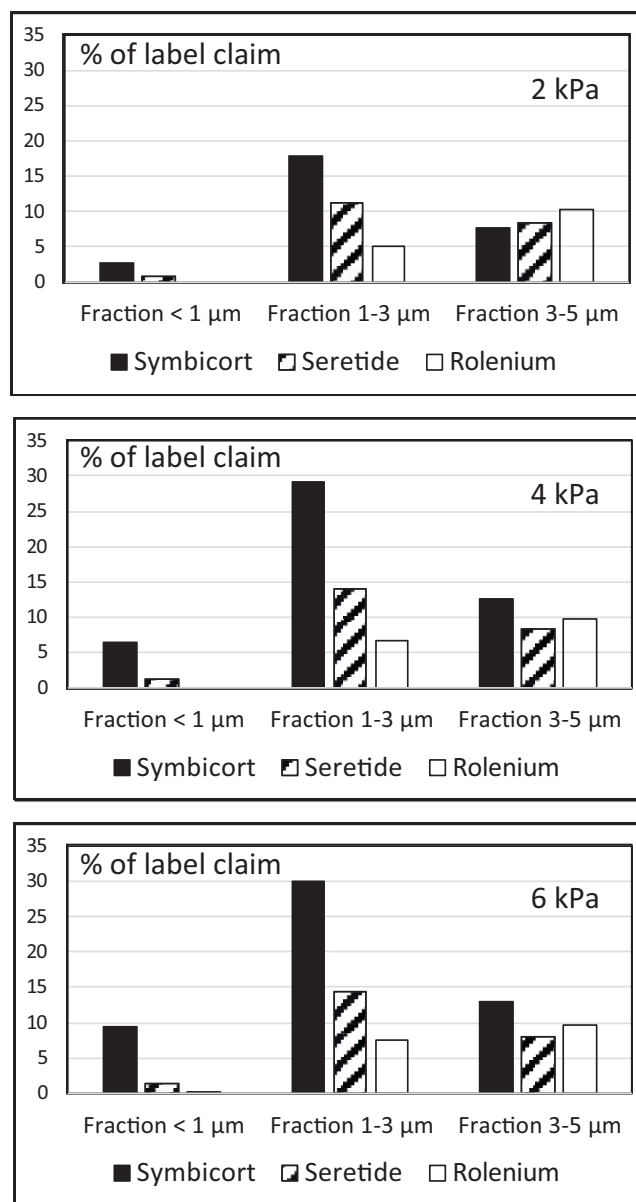

Fig. 14.10 Comparison of delivered fine particle fractions (as percent of label claim) for three different DPIs with comparable fixed-dose ICS-bronchodilator combinations at three different pressure drops. The devices are from three different categories of multi-dose reservoir (Turbuhaler), multiple unit-dose (Diskus) and single dose inhalers (Elpenhaler). The most functional difference however, is that in delivered mass fractions within each size class (<math>< 1</math>; 1–3 and 3–5 μm respectively): see text

weaken the forces between active substance and carrier and the active substance-active substance forces and include for instance also l-leucine [57]. Up to date, only magnesium stearate has been approved by the FDA however, and this excipient is applied in a number of other devices on the market too (e.g., Ellipta and Breezhaler).

Only a few DPIs exist that contain micronised active substance only, or active substance formulated with micronised lactose instead of larger lactose crystals as diluent for the active substance, e.g., Turbuhaler [58] and Twisthaler [59]. The amount of lactose in these formulations is also much lower and to make reproducible dose metering possible, the active substance-lactose mixture is processed into soft agglomerates which have good flow properties, similar to adhesive mixtures. In addition, a special metering device may be necessary, which for the Turbuhaler is an array of scrapers above a rotating disk which has groups of small (conical) holes. The scrapers force the soft agglomerates into these small (conical) holes when the disk is rotated by the patient prior to an inhalation [60]. Such agglomerates have the advantage that they disperse into primary particles much easier than adhesive mixtures [61]. As a result, the oropharyngeal deposition is usually considerably lower, but the agglomerate formulation does not have the same mechanical stability compared to adhesive mixtures. Therefore, dropping or excessive shaking of these inhalers must be prevented.

Whereas the formulations discussed in previous paragraphs are mostly for low dose, locally acting medicines, in the past two decades, there is a growing recognition of the benefits that powder inhalers can offer for the administration of high drug doses and systemically acting medicines too. Also, the interest in vaccination via the pulmonary route is rapidly increasing [62]. Some examples that have already been approved for the market are inhaled antibiotics (tobramycin, TOBI [63] and colistimethate sodium, (Colobreathe) [64], and medicines for treatment of acute disorders (e.g., levodopa) [65] and loxapine [66], although some others failed to become a success (e.g., inhaled insulin) [67]. The advantages of pulmonary delivery of dry powder antibiotics, vaccines and systemically acting drugs are particularly an improved stability compared to aqueous formulations [68], the avoidance of (burdensome) nebulisation or injection (e.g., antibiotics) and a rapid onset of action (e.g., levodopa, loxapine). Many systemically acting medicines are also high dose medicines (in the mg-range), and they require a different formulation strategy. They are often engineered into powders with improved dispersibility, because they are frequently administered to the patient with classic capsule inhalers with poor dispersion performance (e.g., Turbospin for TOBI and Colobreathe). Different techniques can be used to reduce the interparticulate forces that hinder dispersion. They include for instance the manufacture of low density

(i.e. large porous) particles (to change the ratio of removal to adhesive forces) [e.g., 69, 70], particles with reduced contact area (by creating corrugated particle surfaces) [71], or particles co-processed with force control agents (using l-leucine, magnesium stearate or other surfactants; e.g., [57, 72]. They have been described in an abundance of research literature [e.g., 73] and are often produced by spray drying, (spray-) freeze drying or mechanofusion. They are not the subject of this chapter, but they need to be mentioned because they have different properties compared to adhesive mixtures and soft spherical pellets. Because they are usually not further processed after spray(-freeze) drying, their flow properties and mechanical stability as powder are insufficient for multi-dose reservoir inhalers. For that reason, they are pre-metered in single dose compartments, being mostly capsules.

14.3.2.2 The Dose (Metering) Compartment

The three most important DPI functions mentioned in the introduction (Sect. 14.3.2) are strongly related to the design of the dose (metering) compartment. They include protection of the drug formulation from environmental influences or mechanical damage, delivery of a consistent drug dose, and release of the drug dose into the first 0.5–1 l of inhaled air to enable deposition in the central and deep lung. Basically, three different concepts of dose (metering) systems exist: single dose compartments (mostly capsules), multiple unit-dose compartments and dose metering cavities in a movable inhaler part deriving a desired volume of powder from a powder reservoir. The first two types are pre-metered (pre-filled) by the manufacturer. Most single dose compartments need to be placed in the inhaler device by the patient and opened before the dose can be inhaled. Multiple unit-dose inhalers have blisters on a strip or a disk. The patient has to operate the transport mechanism for the strip or the disk prior to use in order to position the next dose for inhalation in line with the mouthpiece opening. Multi-dose reservoir inhalers with powder metering cavities in slides, disks or cylinders also have to be operated by the patient. Because the filling of the metering compartment is by the force of gravity, good flow properties of the powder formulation and holding the inhaler in the prescribed position to make correct use of gravitation are necessary during the filling procedure. In spite of the frequent use of capsule inhalers, they have several disadvantages. For instance, the replacement of an emptied capsule by a new one involves several handling steps and higher numbers of handling steps are usually associated with higher error rates [e.g., 76, 77]. One of the worst errors warned for by the FDA is the mistakenly swallowing of inhalation capsules and/or the inhalation of oral capsules. This risk is higher when patients are colour blind [78] or when similar colour codes for both types of capsules are used. Mixing up medications by patients using polymedication is one of the most frequent error sources in therapies

Different concepts are used as single dose drug compartment of which hard gelatine or HPMC capsules (size 3) are the oldest [e.g., 74], but for many new active substance formulations they are also still the selected type of dose compartment. After the capsule is placed in the inhaler, the capsule wall is perforated or cut with a set of needles or blades, either on one, or on both capsule ends, depending on the type of agitation applied for its emptying. This can be subjecting the capsule to a vibratory, spinning or combined motion (e.g., spinning and wiggling) in the inhaled air stream. Many different principles have been developed for the piercing (puncturing) mechanism as well as for obtaining the desired motion, as described elsewhere [e.g., 44, 75]. During inhalation, the powder particles are directed towards and through the holes in the capsule wall and subsequently entrained by the inhaled air stream.

[79]. Capsule inhalers are the only type of DPI that can be exchanged freely with another device of the same class for the same capsule size, but not without consequences for the performance. This is a risk when patients possess different capsule inhalers that were prescribed for different medicines, particularly when they have preference for the use of one particular device in their collection. The exchange of inhalers can have a significant effect on the properties of the delivered aerosol [80]. Patients may also forget to pierce the capsule before inhaling whereas incorrect capsule storage can influence their piercing performance [81]. Van Renswouw et al. [81] reported for only 32% of all capsule inhaler users good adherence to correct capsule storage conditions, being the result of a lack of knowledge about this aspect in nearly 84% of the users. Dry gelatine capsules may become brittle causing damage during piercing [82], whereas exposure to high humidity may result in indentation without being punctured. Damaged brittle capsules from the puncturing process frequently break further in multiple parts during inhalation, particularly at flow rates of 60 L/min and higher. This can result in incomplete emptying and the inhalation of capsule fragments. Many capsule inhalers are low resistance devices, enabling a high flow rate (> 60 L/min) to assure that complete emptying is within an acceptable inhalation time. The high flow rate contributes to the oropharyngeal drug deposition. Of some devices both low and high resistance versions are available (e.g., Plastiap RS01) [83], but the exchange between devices should not be undertaken without having performed an appropriate *in vitro* comparative evaluation to prove that the delivered fine particle dose is suitable. Gelatine capsules provide poor protection of the drug formulation against a high relative air humidity and often have high pow-

der residues. More recently, alternatives for gelatine have been developed, including hydroxypropyl methylcellulose (HPMC) [84], and different processes are used for their manufacture, resulting in different internal surface properties [e.g., 75, 85]. HPMC capsules have better puncturing performance [82] lower active substance retention, improved aerodynamic performance and provide better stability of the drug formulation compared to gelatine capsules [86]. These disadvantages and potential risks related to capsule type should be carefully weighed against the expected benefit from a particular type of medicine and/or inhaler. There may be alternatives for the same type of active substance, or the same active substance may also be available in another type of inhalation device. Recently, also other single dose, or dual dose, replaceable drug container types are (will be, or have been) used [44]. They are, for instance, aluminium blisters in the Exubera insulin DPI (Pfizer), twin-blisters in the Elpenhaler (Elpen Pharmaceuticals), and plastic compartments in the Cyclops (PureIMS), Dreamboat (Mannkind), Twincaps (Hovione) and Conix-One (3 M).

There is only limited information about patient experience with these relatively new systems. Patient preference studies with the Elpenhaler have revealed that correctly exchanging its dual blister is difficult and requires fine motor skills. For elderly, or patients with impaired sight or motor function, it may be difficult to do it correctly, and this contributed to a low score for this inhaler in various ease of use and satisfaction studies [e.g., 87, 88]. Luinstra et al. [89] investigated the ability of patients with Parkinson's disease (of which 50% were in an off state) to tear the cover foil loose from the dose compartment of the Cyclops disposable dry powder inhaler. Patients were also asked to open the moisture protective foil pouch in which the Cyclops is delivered. Their study showed that the difference in motor function between patients in the on and off state has a significant effect on the success rate for these two handling steps. Hence, by prescribing an inhaler to patients the handling steps for dose preparation must be considered with great care and in the perspective of the patient's cognitive ability, visual impairment and motor skills.

For some DPIs, single dose compartments are clustered on disks (GSK Diskhaler) or strips (e.g., GSK Diskus and Ellipta). For the Diskhaler concept, four or eight blisters are in a circular arrangement on a disk. The blister disks are placed on a rotatable support plate that has holes matching the positions of the blisters to keep the support plate and blister disk in a fixed position relative to each other. The plate is put on top of an inhaler part that has a mouthpiece which is the extension of a chamber into which the blister contents are discharged during inhalation. By rotating the support plate that is connected to a drive over a fixed angle that matches the distance between two blisters, a next dose can be put into position over the discharge chamber for inhalation.

Subsequently, the blister and cover foil are pierced with a plastic pin attached to a flap being part of the inhaler. The number of blisters on strips in the Diskus and Ellipta can be much higher and a simple dose counter may indicate how many doses are left in the device. The strips are coiled and attached to a complex transport mechanism [90]. By bringing a next blister in front of the mouthpiece, the aluminium laminate strip with blisters and the strip of cover foil are automatically separated and wound on different spools, leaving the opened blister with powder facing the mouthpiece. Separating blister and cover foil is much more favourable for emptying than piercing both sides of the blister. As a result of rupture of the lidding foil, its loose flaps may stick into the blister and hinder emptying. After piercing and opening of a blister, the inhaler must be kept level to avoid that powder is spilled out.

Inhalers with a multidose powder reservoir and a metering provision to isolate single doses from that reservoir can contain much higher numbers of doses, up to 200. The metering provision is often a slide with a single cavity (e.g., AstraZeneca Genuair), a disk with multiple cavities (e.g., AstraZeneca Turbuhaler), or a cylinder with multiple cavities (e.g., Orion Easyhaler) (Fig. 14.11). Devices with a slide do not keep measured doses in stock, in contrast with devices having a disk or cylinder. They hold multiple (three to five) single doses isolated from the reservoir. The filling of the cavities is by the force of gravity and for that reason, it is important that the powder formulation has good flow properties and that these properties are maintained during use of the inhaler. This requires that the inhaler is not stored in a very moist environment (e.g., a bathroom) because the moisture protection in a multidose DPI is generally not as good as that in a sealed compartment, because water ingress via moveable parts is possible. It is also important that the inhaler is kept in the correct upright position during dose metering to make gravimetric flowing of powder into the compartment possible and assure complete filling. Generally, a tilting angle up to approx. 30° is not problematic, but a DPI that is to be used vertically should not be kept horizontal. To assist the filling of the metering cavity, the (Teva) Spiromax has an air pump for active transport of powder from the reservoir to the metering cup as indicated with the bellows in Fig. 14.11 [91]. The multidose reservoir DPIs mentioned in this paragraph are exemplary of their type. There are many more examples, often quite exact copies of the proprietary devices with only a few alterations.

14.3.2.3 The Powder Dispersion Principle

Powder dispersion is one of the key operations in many different processes, including dry powder inhalation [92]. During dispersion, active substance particles in the desired aerodynamic size range have to be liberated from the drug

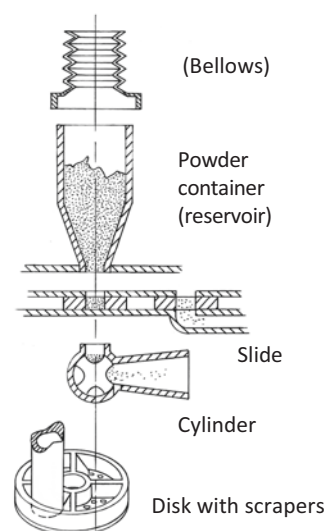

Fig. 14.11 Multi-dose reservoir inhalers with examples of different powder measuring cavities. From top to bottom: a measuring slide (e.g., AstraZeneca Genuair), a rotating cylinder (e.g., Orion Easyhaler) and a rotating disk (e.g., AstraZeneca Turbuhaler)

formulation, which is either an adhesive mixture, or are soft spherical agglomerates. As described in Sect. 14.3.2.1 and shown in Fig. 14.9, it can also be unformulated micronised active substance particles, or active substance co-processed with excipients. It is not possible and not the scope of this chapter to explain the dispersion principles of all currently marketed DPIs. For a proper choice of an inhaler and its instruction for correct operation, it suffices to know how to inhale through a particular device and what fine particle output to expect. Besides, not all DPIs do have a distinct inhaler part for dispersion. The first successful inhaler on the market (Spinhaler) had pre-metered doses in single hard gelatine capsules that needed to be punctured with needles after being placed on a wiggling propeller in the inhaler. During inhalation the propeller rotated the capsule to propel the powder towards the powder release holes in the capsule wall by centrifugal force [74]. Different agitation techniques have since been developed for other capsule inhalers. This makes them different from several multi-dose reservoir DPIs that do have well-defined dispersion principles, such as cyclones or classifiers. There may be an optimum in particle size regarding the efficacy and rate of capsule emptying [e.g., 74], which depends on the capsule motion and the size of the discharge holes. Recent studies into the mechanism(s) of dispersion in the Aerolizer capsule inhaler confirmed the risk of mixing up capsules and inhalers, as the dispersion efficacy may depend on the drug formulation, particularly the fineness of the lactose excipient [e.g., 93].

Complete dispersion of inhalation powders with a DPI is impossible, particularly for adhesive mixture formulations.

Most industrial dispersers operate at a pressure of a few bars (a few hundred kiloPascal, kPa) whereas patients are generally unable to generate pressure drops higher than 6–8 kPa across a DPI, although this depends on its resistance to air flow. Particularly when the inspiratory function is impaired, as in COPD, patients may find it difficult to generate even 4 kPa. For this reason, *in vitro* performance data of DPIs are mostly presented for a pressure drop of only 4 kPa across the device [94]. Dispersion principles for inhalation powders have to establish at least locally a high velocity for the inhaled air stream through the DPI, to create sufficient kinetic energy for the dispersion process. To this purpose, narrow passageways for the inhaled air stream or circulation, classifier and whirl chambers are applied. They increase the inhaler resistance to air flow and as a consequence, many DPIs with effective dispersion principles have a moderate to high resistance (R), ranging from approximately 0.015–0.060 kPa^{0.5}.min.L⁻¹. This is the resistance derived from a general equation expressing the relationship between the generated pressure drop (dP in kPa) across an orifice and the flow rate (Φ in L.min⁻¹) corresponding with that pressure drop:

$$dP^{0.5} = R \cdot \Phi$$

This equation is fairly well applicable to all currently marketed inhalers. Hence, the flow rates corresponding with 4 kPa across DPIs range from 133 L.min⁻¹ (for R = 0.015 kPa^{0.5}.min.L⁻¹) to 33 L.min⁻¹ (for R = 0.060 kPa^{0.5}.min.L⁻¹).

14.3.2.4 The Inhaler Housing with Control and Feedback Functions

The inhaler housing has to hold the functional inhaler parts together in the correct assembly and protect these parts and the drug formulation from pollution and (mechanical) damage. In multi-dose reservoir inhalers, special care is also given to protection of the formulation against moisture uptake from the air. Additionally, and depending on the class (Fig. 14.8) and the type of inhaler, different control functions for correct handling and operation of the DPI may be present. For most control functions, e.g., transporting the dose mechanism, different solutions exist and they must assure reliable inhaler performance and be, above all, easy to accomplish. To make this possible, the inhaler must have an ergonomic design. Also, the number of handling steps must be minimised and operation must be intuitive. Replacement of a dose compartment (e.g., capsules) involves several handling steps, which include taking a new one from a storage container and safely disposing of the emptied one. For some inhalers this may expose the patient to difficulties, as has already been described for the Elpenhaler (Sect. 14.3.2.2). When inhalers have to be opened or taken apart to replace

emptied dose compartments, it must be ascertained that closing, or re-assembling of the device after a new compartment has been inserted, is always correct. Only when a preloaded single dose inhaler is disposable, dose activation mostly includes only one handling step, such as peeling off a lidding foil from the dose compartment. But even this, in its simplicity, can become an insuperable obstacle for some elderly patients, as has been shown by Luinstra et al. [89]. Similar difficulties are met by such patients when they have to open the foil pouches in which many new DPIs are delivered to

The inhaler housing can also be used to adjust the resistance to air flow of the device, e.g., by adding a bypass flow of clean air to the aerosol, or by implementing a flow constriction on the air inlet. The design of the housing must further prevent that the patient has access to functional inhaler parts to which access should be denied, including the powder formulation. In addition, its design must exclude accidentally closing of the air inlet openings with the fingers during inhalation as good as possible. Finally, signalling functions to the patient may be added, such as the number of doses left in the device and a feedback signal on the inhalation manoeuvre. Feedback and monitoring may be an integral part of the inhaler design, but recently various add-on devices have been, or are being developed that communicate via special apps with smart phones for data processing and storage. The total package of attributes must suit the individual patient, as good satisfaction with their device increases the rate of correct inhaler use and the adherence to the therapy.

protect them from moisture uptake from the air.

A great concern is the introduction of a plethora of new DPIs to the market of which the precise working principle and, because of that, the critical action points and the most optimal inhaler technique are frequently not known [95]. Particularly the introduction of generic DPIs to the market contributes to ignorance about their precise working principles and uncertainty and confusion about how to operate them best. This hinders correct instruction. Many multiple-unit dose or multi-dose reservoir DPIs of the same type have a lot in common regarding their design. Yet there may exist various disparities in their mode of operation. For instance, the Turbuhaler and Twisthaler both have a hood screwed to the base of the DPI that needs to be twisted off before the inhaler can be used. The confusing difference between these very much similar looking devices is that removing the hood from the Twisthaler automatically also loads a dose, whereas

for the Turbuhaler dose loading requires that the base of the inhaler is rotated to and fro over a certain angle relative to the upper part of the device, after the hood has been removed. Patients being familiar with the Twisthaler may forget to do this when they are switched to the Turbuhaler. Some other multi-dose inhalers have a construction that enables to slide (e.g., Diskus) or hinge (e.g., NEXThaler) a hood over (and from) the mouthpiece. Such hoods are inseparable from the inhaler housing and they may also be used to load a dose when they are displaced to clear the mouthpiece (e.g., NEXThaler). This can prevent that dose activation is forgotten.

Recently, since the expiration of the GSK Advair patent, several generic salmeterol/fluticasone combination products have been developed (e.g., by Neutec, Mylan, PMS, Glenmark, Sandoz, Cela Pharma, Hikma), of which the first (Mylan Wixala Inhub) reached the market in 2019. They all make use of the same inhaler concept as the Diskus and several more are likely to follow. They have the same active substance combination in the same strengths, the same blister strip technology and a rotatable cap closing the mouthpiece. Yet there are several minor differences that can have an effect on correct inhaler use and, thus, the therapeutic efficacy. All devices have a comparable lever for transporting the blister strip too, except for the Neutec Airmaster, which is a one-step device, meaning that opening the cap is integrated with transport of the blister strip. To prevent accidental dose activation the cap is blocked in closing position. To unblock the cap, a knob has to be pressed and this requires the synchronisation of two different operations. For the Sandoz Airflusal Forspiro, the transport lever includes the entire top part of the inhaler, including the mouthpiece which is tilted away from its correct position during dose activation. Subsequently, this hinging top part with the mouthpiece has to be closed and clicked into place again for good inhaler performance. Some

devices have exactly the same appearance (shape, size and colour) as the Diskus (e.g., the PMS inhaler), whereas other inhalers have different shapes (Fig. 14.12). Instead of being a disk, lying flat at rest, they are more or less oblong, or have another shape that enables them to take a vertical standing position. This may tempt the patient to hold them in a vertical position too while operating the blister transport lever. However, only for the Mylan Wixala Inhub a vertical position is indicated in the instruction leaflet, whereas for the Sandoz Forspiro the precise position is not clear. All other devices have to be used level flat, similar to the Diskus, to prevent powder waste from the opened dose compartment. There are also differences in resistance to air flow between these generic devices and all these differences may contribute to confusion or inability and incorrect use when patients need to change from device, e.g., for budgetary reasons. Differences in DPI instructions, resistance, performance and error use, may not always become clear from bioequivalence studies. A few studies are available from which bioequivalence between the originator product (Diskus Advair) and the Mylan Wixala Inhub was concluded [96, 97]. For such studies, patients or healthy volunteers are recruited and included on specific characteristics however. They are also well-instructed and often monitored during inhaler use and excluded from the study when they show improper inhaler technique. This sets the prerequisites for being bioequivalent, but it has little relevance to real life use of these inhalers [98].

The task of the instructor is to know the differences in operation procedures between DPIs and to make the patient aware of the necessity to do the steps in a correct manner. It is also the responsibility of the healthcare professional to select the most appropriate type of device for patients when they have difficulties with inhaler use for whatever reason. It has been suggested that matching the device to the patient is even a greater challenge and a better course of action than

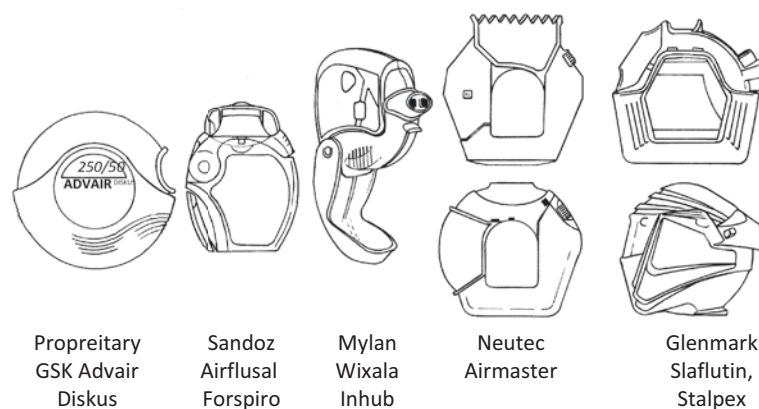

Fig. 14.12 Different generic Advair (fluticasone propionate/salmeterol xinafoate fixed dose combination) examples in different inhaler designs

training and retraining a patient to use a specific inhaler device [98]. There are several operational steps that may seem feasible for everybody to accomplish correctly, but various sensory and motor function deficits can make this difficult or impossible. The risk of incorrect operation increases when the ease of displacing, opening or closing inhaler parts is influenced negatively by inhaler pollution or damage. When powders spread between moving parts, the friction between these parts increases and this is usually the result of insufficient emptying of the dose compartments during inhalation (due to poor inhalation technique). Therefore, correct inhaling is not only necessary for achieving appropriate aerosol properties and adequate lung deposition, but also for good inhaler functioning. Spreading powder in its interior can also result from making unintended movements with the inhaler between opening of a dose compartment and dose inhalation. This can be the consequence of reduced dexterity or distraction of the attention during the inhalation process. Stiff movement of inhaler hoods or transport levers and knobs used for driving the dose transport mechanisms in multi-dose inhalers is a frequent error cause for not completely reaching the endpoints of these levers and knobs. Patients must, therefore, be able to notice with multiple senses (hearing and seeing) that the endpoint(s) of the stroke(s) are achieved.

Most currently marketed multi-dose inhalers indicate the number of doses left in the device, but only a few inhalers give feedback to the patient about the inhalation manoeuvre. Feedback may assist the patient in delivering the correct inspiration effort, which for DPIs is not necessarily 60 L/min or higher, as is still frequently mentioned [99, 100]. The first DPI on the market having a visual and acoustic signal was the Novolizer [101]. This device, similar in design as the Genuair, has a window connected to the air valve that changes colour when the flow rate achieves the threshold value that causes the valve to switch (and reset the dose measuring slide). This threshold value has been chosen to be <45 L/min, which is sufficiently high for these inhalers to deliver a consistent fine particle dose. Switching of the valve also produces the acoustic signal informing the patient that the required flow rate has been achieved and needs to be persevered up to vital capacity. Not being able to succeed in making the valve switch is often the result of having insufficiently exhaled prior to inhalation. This limits the inhaled flow rate and instructors should use this to make patients aware of this omission. Without valve switching, a next dose cannot be metered. Mechanical indicators cannot store data however, and with simple electronic transducers within the DPI, only the inhalation manoeuvre itself can be monitored. This primarily provides information about correct inhaler use, not about correct inhalation for lung deposition for which deep prior exhalation and a breath hold pause are equally important.

14.4 Nebulizers

Section 14.4 deals with all currently used wet aerosol delivery devices that differ from MDIs. This includes jet, ultrasonic and vibrating mesh nebulizers, soft mist inhalers (i.e. impinging jets) and devices making use of Rayleigh break-up. They will not all be discussed in the same detail as MDIs and DPIs as their employment is relatively scarce. Jet and Ultrasonic nebulizers are the oldest type of pulmonary drug delivery devices, but in most European countries liquids for nebulization comprise less than 5–10% of total pulmonary retail sales, with a few exceptions including Norway (about 15%) and Portugal, Switzerland and Belgium with approximately 20% [102]. These percentages are expected to decrease further in favour of DPI-use thanks to the development of antibiotic dry powder formulations and disposable DPIs for rescue medication. Italy is the only European country where nebulization contributes over 40% to inhaled products. In nearly all European countries DPIs are the preferred type of delivery system for inhaled medicines, except for the UK where MDIs are more popular. Nebulizers are not very effective, nor patient-friendly and, therefore, they should not be considered when there exist suitable alternatives for the same active substance (or active substance combination). There are only a few, mostly high dose, medicines that can still exclusively be administered with nebulizers, and also for one-off use (in the hospital and nursing home situation) or clinical testing they may be the only possibility. In contrast with DPIs and MDIs, classic jet and ultrasonic nebulizers are mostly used exclusively under supervision of medical personnel. The division of the global nebulizer market into end users in 2019 shows that nearly 67.5% of all devices is deployed in hospitals and clinics, around 20% in emergency centres and only approximately 12.5% in home healthcare. This includes vibrating mesh inhalers (see Sect. 14.4.3) and it implies that in most cases medical staff is responsible for correct use of these devices. This shifts the target for instruction from the patient to the healthcare professional.

Nebulizers are wet aerosol generation devices for aqueous active substance solutions and suspensions and for long they could be divided into only two classes of (air-)jet and ultrasonic nebulizers [e.g., 103, 104]. New principles added are impinging jets [105, 106] and Rayleigh break-up [107]. The latter principle refers to the break-up of thin liquid jets extruded through pores in a membrane while applying a constant pressure on the liquid. It has been used to develop the AERx (Aradigm) pulmonary drug delivery system for insulin and the Ecomyst inhaler (Medspray), but neither of these principles has (yet) been commercialised successfully. Therefore, they will not further be explained. Figure 14.13 shows all currently used techniques and techniques in development schematically. Several others are neither on the market yet or have meanwhile been rejected as being not suitable

for drug delivery. They include for instance electrospray, or electro-hydrodynamic atomisation: EHDA [108], condensation, or capillary aerosol generation: CAG [109, 110] and inkjet printer technique [111]. Also spinning disk (or top) aerosol generators (STAGs) have been used in the past to produce aerosols for clinical experiments [e.g., 112]. Many of these principles produce monodisperse aerosols and the principle of heating a liquid into a gas and subsequently cooling the vapour in order to condensate the gas into small droplets (CAG) is currently widely applied for e-cigarettes [113].

14.4.1 Ultrasonic Nebulizers

Most ultrasonic nebulizers used are essentially humidifiers. They were introduced in the middle of the twentieth century and into the twenty-first century they have a small and rather constant share of the nebulizer market in North America and Europe of about 15%, compared to 67% for jet nebulizers and 18% for vibrating mesh devices. Their principle of operation has been described before [e.g., 114, 115] and it is based on the use of piezoelectric crystals that start oscillating when an alternating electrical potential is

applied across their surfaces. The oscillation is transmitted as acoustic pressure waves to and through the liquid towards its surface, which forms crests and troughs of which the wavelength is related to the frequency of the oscillating piezoelectric crystal. Figure 14.13 shows schematically that there are two different types: those in which the drug solution or suspension makes direct contact with the oscillating transducer (Fig. 14.13, (2)), and those having an inner reservoir for the drug solution that is placed in an outer reservoir with cooling water (coupling liquid) for indirect transmission of the oscillation to the drug formulation (Fig. 14.13, (3)). The indirect nebulizer type with cooling bath may be preferred for thermally labile active substances, as the temperature of the active substance solution can increase significantly during the nebulization process. However, the liquid level in the cooling bath relative to that in the active substance reservoir may be of great influence on the aerosolization process. Therefore, using indirect ultrasonic nebulizers may be more critical than using direct types. There is very limited control of the particle size distribution also for devices with direct transmission making ultrasonic nebulizers rather unsuitable for the administration of inhalation medicines. For this reason, they will not be further discussed, but those being inter-

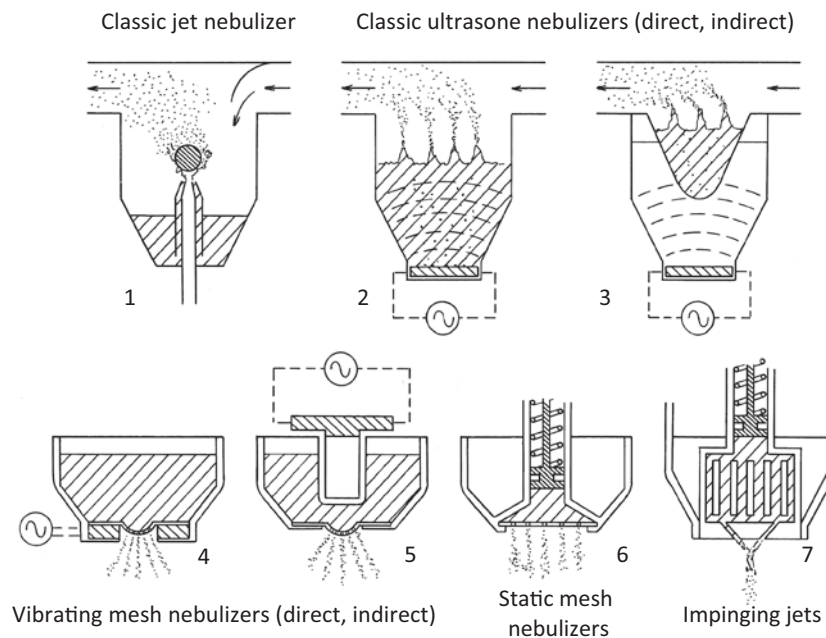

Fig. 14.13 Schematic presentation of different wet aerosol generation principles. Jet nebulizers (1) use pressurised air as energy source for the aerosolization process. Ultrasonic devices (2 and 3) have piezo transducers that create pressure waves in the drug solution. Vibrating mesh nebulizers either have a piezo transducer attached to the mesh itself (4) or a piezo transducer to oscillate a horn that sticks in the drug solution

(5). They are referred to as direct and indirect, or active and passive devices respectively. Static mesh nebulizers (6) and impinging jet inhalers (7) apply a constant pressure on the liquid to force it through a mesh (perforated membrane) and two angled microfluidic nozzles respectively

ested are directed to an excellent review of Yeo et al. [116] who presented and discussed many specific pros and cons of ultrasonic nebulizers.

14.4.2 Jet Nebulizers

Jet, or rather two-fluid nebulizers are by far the most common type of nebulizer worldwide [117], see Fig. 14.14. Currently used nebulizer cups consist of a liquid reservoir for the drug solution or suspension having two concentric vertical tubes inside of which one has a connection with the drug solution or suspension (fluid 1) at its bottom and the other one is used for the passage of compressed air, or any other suitable gas (fluid 2). This gas flow is referred to as jet flow. The jet flow is mostly through the inner tube and the liquid flow through the outer capillary. The gas tube ends in the immediate vicinity of the tip of the surrounding liquid pipe and may have a narrowing to increase the gas velocity. Momentum transfer from the high velocity gas stream to the surrounding air causes entrainment of liquid from the liquid pipe. As soon as the liquid reaches the tip of the channel, it is disrupted into ligaments that fragment further into droplets due to the instability of the liquid sheet caused by the great velocity difference between the gas and liquid flow. The jet flow rate affects thus both the output rate and the droplet formation process. A higher jet flow rate decreases the droplet size distribution and increases the output rate of the nebulizer. The jet flow also creates an air circulation in the nebulizer cup by entrainment of the air that surrounds the nozzle tip. The cup may be designed in such a way that this circulation leads to the influx of air past the nozzle area from the environment via an open vent. This flushes the nebulizer cup and brings more aerosol to the mouthpiece of the nebu-

lizer, but it can also lead to substantial waste of aerosol to the environment. Jet nebulizers are operated with a portable compressor for the gas flow (jet flow) or connected to a pressurized air, or (oxygen) gas circuit.

The mechanism of droplet formation with two-fluid nozzles is complex, still not yet fully understood, and varies between different nebulizer nozzle designs [118]. Most dominant are high shear forces which are the result of a great difference in velocity between the gas and liquid jet [119]. The droplet formation mechanism with a two-fluid nozzle is not the primary determinant for the droplet size distribution of the aerosol as delivered to the patient however. Generally, one or more baffles (droplet impaction objects) are placed in the gas-liquid stream at a short distance from the nozzle exit to collect droplets that are too large for central and deep lung penetration. These droplets partly disintegrate into finer droplets and are partly returned to the liquid reservoir, depending on the specific baffle design. Only fine droplets in the desired size range may pass the baffle and mix with the inhaled air stream. This process of classification substantially reduces the output rate of a nebulizer. As much as 90–99% of the droplets released from the nozzle are returned to the reservoir [117, 120] and have to take part in the atomisation process again.

Droplet size distribution for a particular nozzle concept is particularly influenced by the properties of the drug solution or suspension [121]. The viscosity and the surface tension of the liquid are the most relevant variables to the droplet for-

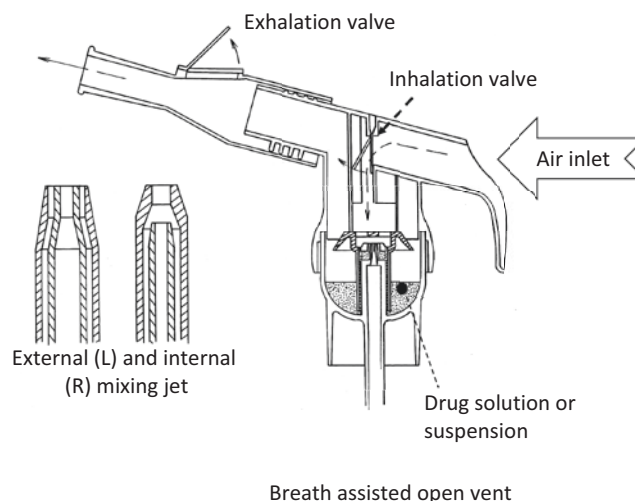

Fig. 14.14 The principle of operation of a jet nebulizer with a two-fluid nozzle. See the text for a more detailed explanation

mation [122], but due to significant liquid evaporation and changes in temperature of the drug formulation during the nebulization process, they are altered. Therefore, and because of the great variety of nozzle designs and the complex interaction between the physical properties of the drug solution, theoretical approaches for the prediction of the droplet size distribution are mostly unsatisfactory and not generally applicable [123]. At best, some practical rules of thumb hold for most systems, saying that:

- Increasing the surface tension of the liquid decreases the (average) droplet size,
- Increasing the viscosity increases the (average) droplet size, and
- Increasing the jet flow will result in a higher output rate, but also in a finer aerosol

It is important that when a particular type of nebuliser-compressor combination has been evaluated and approved for the administration of a particular drug solution, it should not be used for other drug formulations without checking that the aerosol properties are acceptable for that other active substance too. Also, mixing of drug formulations (to reduce total daily nebulisation time) can potentially alter the performance of the nebuliser to the extent that makes the aerosol for at least one of the active substances in the mixture unsuitable for deposition at the intended site.

The nebulization process stops when no longer liquid can be drawn through the capillary tube to the tip of the nozzle where the dispersion takes place. This ‘dry running’ occurs when there is still some liquid in the cup and these residual cup volumes may depend on the design of the cup and vary from less than 1 mL to more than 2 mL of ‘bulk liquid’. Dry running is also referred to as ‘sputtering’, as by the time there is insufficient liquid in the nebuliser cup, the aerosolization process becomes intermittent before it stops entirely. For the administration of a precise drug dose, these residual volumes must be taken into consideration. Residual volumes are not the only variables determining the delivered dose to the patient however. This also depends on ‘aerosol waste to the environment’, as will be explained in one of the next paragraphs. The recirculation of liquid in the nebulizer cup and the continuous increase in air-liquid interface during dispersion of the bulk liquid into small droplets causes substantial liquid evaporation and cooling of the drug solution, due to the extraction of heat of evaporation. It has the consequence that the drug concentration increases during the nebulization process. This, in combination with the temperature change, affects the viscosity and the surface tension of the bulk liquid in the reservoir. Hence, a change in particle size may be expected during the nebulization process [121]. It also makes computation of the delivered drug dose more complex.

The constant jet flow results in constant aerosol production and this causes significant loss of aerosol to the environment as the emptying of the nebulizer cup is intermittent and

controlled by the breathing rate of the patient. For this reason, corrugated tubes or collection bags for the aerosol have been used to increase the storage volume for the aerosol during exhalation [124]. To reduce the waste of aerosol to the environment, which is a risk for healthcare workers too, also different types of vented nebulizers have been developed that have an influx valve. They draw extra air through the nebulizer cup only during inhalation [120] and are often referred to as breath-assisted (or enhanced) nebulizers and examples are LC Plus (Pari) and SideStream Plus (Philips Healthcare). If the aerosol generation process is interrupted during exhalation, the term breath-actuated nebulizer (BAN) is used. The most cited BAN in literature is the AeroEclipse (Trudell Medical), but different designs may be possible, including manually operated concepts.

Many classic jet nebulizers are rather inefficient in drug delivery to the lungs, unless special designs are used and specific measures are taken [e.g., 125]. Ex-mouthpiece doses are generally low and vary between approximately 10% and 60% of the loaded dose [e.g., 126–128]. This depends on their design, the fill volume and residual volume of the cup, the properties and concentration of the drug solution, and the breathing mode of the patient. No more than approx. 10% of the loaded dose may be in the ‘respirable range’ 1–5 μm [120]. Jet nebulizers are also general-purpose devices. They are not specifically designed for the administration of a particular active substance and are used for a great variety of drug solutions and suspensions, for which there is no good alternative in a DPI or MDI. There are only a few exceptions of jet or vibrating mesh nebulizers being approved for a newly developed medicine, like for instance the Pari LC Plus with DeVilbiss Pulmo-Aide compressor for TOBI (tobramycin nebulisation solution, Novartis). Not only nebulizer cups are available in a wide variety of different designs for jet nebulizers, there exists also a great variety of different compressors for the gas flow. Compressors yield different pressures for the jet flow through the same type of nebulizer cup [129], which has great effect on the droplet size distribution obtained [126, 130–132]. Random selection of a nebulizer-compressor combination for a particular drug formulation can give great uncertainty about the properties of the aerosol and the efficacy of the therapy. Studies have shown that differences in MMAD as great as between 1 and 10 μm for the same drug solution from different nebulizer-compressor combinations are possible [133]. In hospitals, nursing homes and emergency centres, often compressed air (or oxygen) from a circuit (‘wall air’) instead of a compressor is used. Common practice is the use of a flow meter to adjust the jet flow rate from the circuit through the nebuliser cup. However, the flow meter may have a completely different air flow resistance compared to the nebuliser cup and this results in a different flow rate through the nebulizer cup too. Even worse is the habit of turning up the jet flow until a visual aerosol is produced. This gives no control over the aerosol properties whatsoever.

Increasing the fill volume relative to the residual volume, usually with 0.9% saline solution, increases the delivered dose, but it also increases the nebulization time [126] whereas it may change the droplet size distribution too. New nebulizer cups may have higher residual volumes than used ones, due to the presence of fatty layers from the moulding process [131]. This results in the adherence of large droplets onto the inner walls of the cup. In the treatment of patients with contagious diseases, often disposable nebulizer cups are used. Such cups are normally disposed of after single use, or used only a few times by the same patient within a limited period of time (e.g., 24 h). It has been shown that disposable cups exhibit a high frequency of malfunction however, such as an inappropriate particle size distribution (with a large inter-cup variability), air leakage, leaking nebulizer solution and variable output rate [134].

14.4.3 Vibrating Mesh Nebulizers

Vibrating mesh nebulizers exist in two different types (Fig. 14.13). Both types have in common a small liquid reservoir for the drug solution and a thin perforated membrane (mesh), with small (tapered) holes, that is in contact with the drug solution. They differ in the principle by which the drug solution is forced through the pores of the mesh, using pressure waves introduced by a piezoelectric transducer. Either the high frequency vibration from the piezoelectric transducer

is directly applied to the mesh itself (active mesh nebulizer), or the mesh is stationary (for passive mesh nebulizers) and a horn in the drug reservoir is used to introduce the pressure waves to the liquid. Examples of active mesh nebulizers are the Aeroneb Solo and Pari eFlow (rapid), whereas the Omron Micro-air U100 and NE-U22 are nebulizers with a vibrating horn in the drug solution. More about the design and working principle of vibrating mesh nebulizers can be found in Chemmalasseri [135], Lass et al. [136] and Olszewski et al. [137].

The main advantage of mesh nebulizers is the uniformity, precision and consistency with which the droplets can be generated. In principle, when all holes have the same size, the generated aerosol is monodisperse with droplets having diameters of approximately twice the mesh size. In practice, various effects, including droplet evaporation and coalescence, result in a narrow size distribution. Additional advantages are a relatively high output rate from the large number of holes in the membrane, and compared to classic jet and ultrasonic nebulizers a reduced active substance waste, improved portability and silent operation. Also, in contrast with jet and ultrasonic nebulizers, the changes in temperature and concentration of the drug formulation during the nebulization process are negligible [138]. An example of a marketed device, the Pari eFlow (rapid) is shown in Fig. 14.15. This eFlow technology (under different names) is approved by the FDA for the delivery of tobramycin solution (TOBI, Novartis), glycopyrrolate solution (Lonhala, Sunovion) and amikacine liposomal suspension (Arikayce, Insmed). Similar to classic jet nebulizers, vibrating mesh nebulizers can be used for a wide range of other drug solu-

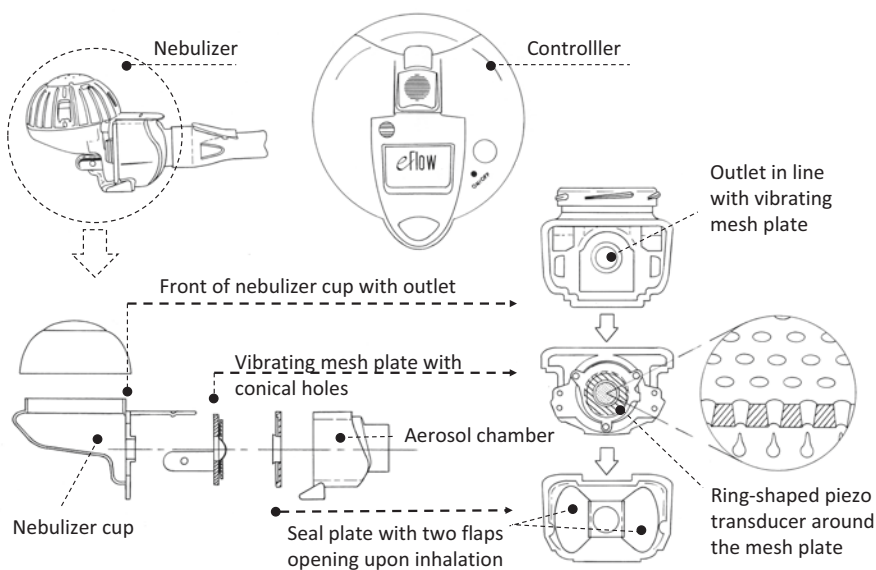

Fig. 14.15 Design of a vibrating mesh nebulizer (Example Pari eFlow Rapid). The eFlow consists of the aerosolization device (nebulizer) and a controller (top figures). The aerosolization device has a vibrating

membrane (mesh plate) in front of the outlet opening of a drug reservoir (nebulizer cup) and a seal plate with two valves to mix inhaled air with the aerosol in the aerosol chamber

tions and suspensions too, but this has the same disadvantages as described for jet nebulizers.

Mesh nebulizers may be more appropriate for use in mechanical ventilation circuits than jet and ultrasonic devices because their performance seems less susceptible to not holding the nebulization cup in an upright position, although some studies suggest otherwise [139]. A device frequently used for mechanically ventilated patients is the Aerogen Solo. One of the limitations for the use of mesh nebulizers is that most marketed medicines for nebulization have been prepared in a volume for jet nebulizers that is too large for their medication reservoirs [140]. Reduction of the volume is not possible without reducing the drug dose too. Several studies have shown that vibrating mesh nebulizers are rather susceptible to clogging, particularly when cleaning is not performed according to the prescriptions [141, 142].

14.4.4 Soft Mist Inhaler Respimat

The aerosol generation with the Respimat, also referred to as soft mist inhaler (SMI), is with two impinging nozzles [143]. The Respimat is delivered with prefilled cartridges which excludes using the device for other drug solutions than those it is meant for. Its design has well been described in the past [e.g., 144]. In summary, the inhaler has a multi-dose drug reservoir and a small metering chamber (15 μL) to isolate individual drug doses from the cartridge. Upon pressing a knob, the liquid dose is forced by mechanical power from a preloaded spring through a filter unit (Uniblock) to two angled nozzles producing two intersecting jets that collide with each other at short distance (25 μm) from the nozzle tips [143]. The collision of the jets creates a slowly moving mist with a high mass fraction of fine particles and the aerosolization of 15 μL of the drug solution requires approximately 1.2–1.6 s. The Respimat can be delivered with 60 or 120 doses and a blocking mechanism prevents that more doses are taken than labelled. This is one of the advantages compared with MDIs as it prevents tailing off. Additionally, the slow plume velocity and long spray duration reduce problems with hand-long coordination compared with MDIs [145]. These advantages meet the objectives to minimise incorrect inhaler use with SMIs [146]. Nevertheless, inhaler use errors are very common with SMIs too. Compared to MDIs, with on average 77–87% errors, SMIs score significantly better with 59%, but still not as good as DPIs (50%), as has been concluded from a global systematic literature review by Navaie et al. [146]. Patients' acceptance of the Respimat has been reviewed by Hodder and Price [147] who reported significantly greater satisfaction than with an MDI. Respimat SMI is available with tiotropium bromide (Spiriva), olodaterol (Striverdi) and the combination of both active substances (Spiolto/Stiolto).

14.4.5 New Developments and Add-On Devices

In addition to the development of new aerosol generation principles, various techniques have been proposed and developed to improve the drug delivery from existing wet aerosol delivery devices [148]. For instance, mesh nebulizers can be operated for adaptive aerosol delivery: AAD [149, 150]. Such a system (e.g., for the I-neb, Philips Respironics) has the ability of precision dosing and to adapt the aerosol delivery to the patient's breathing pattern by releasing aerosol only during inhalation. This prevents loss of aerosol to the environment during exhalation. The system also assists the patient in realising the correct breathing mode. More details about the procedures can be found in the references Dhand [149], and Denyer and Dyche [150]. A comparable system for classic jet and ultrasonic nebulizers is the AKITA system (Vectura) [151, 152]. Interfaces between the nebulizer and the patient are mostly face masks used for paediatric patients (infants and toddlers) that are unable to understand and/or execute a correct inhalation manoeuvre (Fig. 14.16). Masks for nebulizers (Fig. 14.16a) generally have holes to decrease ocular and facial impaction and to prevent rebreathing of exhaled gases. Berlinski [153] showed that occlusion of the holes, which appears to be common practice, or the volume of the face mask does not change the lung dose. For masks on valved holding chambers do not have these holes and need to fit closely to prevent leakage of false air.

14.4.6 Drug Solutions, Suspensions and Excipients for Nebulization

Most formulations for liquid aerosolization are prepared by community and hospital pharmacies and they are often administered randomly with the nebulizers being available. They include mainly compounds for antibiotic or antifungal treatment, and bronchial provocation tests. Only a few inhalation medicines for nebulization are on the market and they are generally approved for administration with only one particular type of nebulizer. Drug solutions and suspensions used for nebulisation are furthermore often trade products for injection. In many cases they need to be diluted (e.g., with 0.9% saline) and the pharmacist must take care of, or advise about the dilution (and/or mixing) procedures. Many classic nebulizers have a residual volume of 1–2 mL and this loss must be taken into consideration when preparing a nebulisation liquid, or the delivered dose will be much lower than intended. Some solutions do have a poor chemical stability, and they need to be freshly prepared. For instance, colistimethate sodium (CMS) is known to hydrolyse spontaneously into polymyxin E and E2/B when dissolved in water and high levels of these active breakdown products have been associated with nephro-

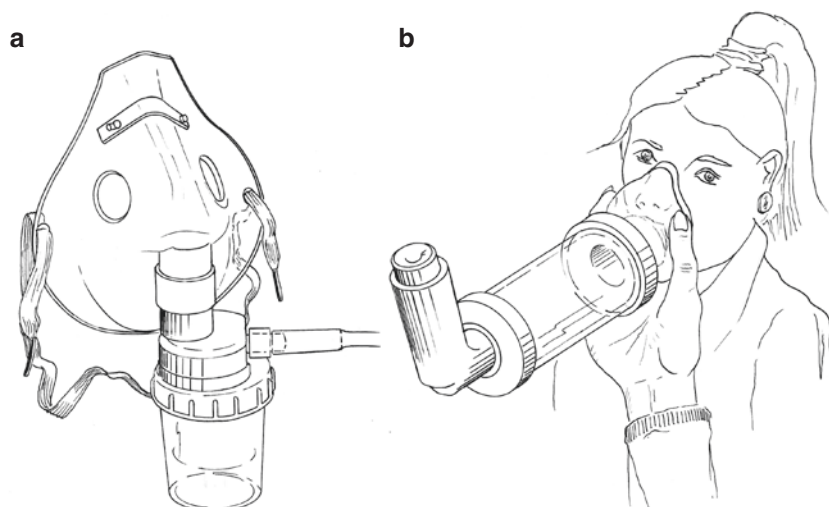

Fig. 14.16 Difference between the face masks for nebulizers and MDIs with valved holding chambers (VHCs). (a) Face mask for nebulizer. (b) Face mask for valved holding chamber (VHC)

toxicity [e.g., 154, 155]. The most important aspects to consider for liquid nebulizer preparations in addition to sterility and chemical stability are acidity and osmolality. They are adjusted by adding excipients. The pH of nebulization liquids may not be beyond the range from 3 to 8.5. Procedures and excipients for the preparations and adjustments can be found in the literature [e.g., 156–158]. Mixing of drug formulations is common practice for nebulization and it has the objective to reduce the burden of administration for patients having to administer multiple nebulized active substances. The result of a search in databases and literature regarding the chemical and physico-chemical compatibility of inhalation solutions and suspensions can be found in Kamin et al. [159] and Burchet et al. [160]. A good review on the effects of shear flow on protein solutions, with several examples from literature, is given by Bekard et al. [161].

14.4.7 Maintenance and Cleaning of Nebulizers

Nebulizers are wet aerosol generation devices which makes them sensitive to pollution. Most nebulizer types have small holes for the droplet generation process that may contain liquid residues with active substance and excipients in solution or suspension after being used and without being cleaned. Liquid residues containing antibiotics or antifungals may lead to bacterial resistance building when these organisms can enter the administration device. After drying, these residues can decrease the inner diameter of such holes, or block them completely, which has a great effect on the aerosolization process. Cleaning and disinfection protocols from the manufacturers have to be preferred, because they take all the

device-specific requirements and points of attention into account. It is the responsibility of the prescriber to make certain that the correct protocols are provided to the patient.

14.5 New Developments and Some Future Expectations

There are currently several developments going on that may have an effect on the inhaler choice, the instruction and the efficacy of the therapy. In most cases however, there is simply insufficient information yet to evaluate these developments thoroughly. Therefore, they will not be described in detail in this paragraph, but the prescribers of inhaled medicines must be aware of their existence and keep themselves informed about the progress made. Developments of interest for inhaler use are for instance feedback and monitoring devices connected to the inhalers that inform the patient about correct inhalation and the healthcare professional about the patient's adherence to the therapy, respectively. They may be accurate and effective but not be appreciated by all patients and their doctors for different reasons. A better adherence may also be expected from reducing the patient burden of nebulisation by prescribing a dry powder inhaler. DPIs have and will become available for various antibiotics like colistin, tobramycin and ciprofloxacin using PulmoSphere powders or more effective high-dose DPIs. New delivery technologies as the AERx (Rayleigh break-up) platform (Aradigm), Technosphere (self-assembling carrier) Technology (MannKind Corp) and the Staccato (condensation aerosol) Technology (Alexza Pharmaceuticals) may seem promising for improved lung delivery, but for some of the medicines (e.g., insulin) in these new systems there is

poor acceptance for pulmonary delivery. This makes their future uncertain. Fixed-dose combinations in asthma and COPD therapies can reduce the number of inhalers used and generic inhalers can lower the cost of the therapy, when the performance of the devices is comparable to the originator products. This is certainly not always the case, whereas inhaler handling may be rather different too and result in more errors or an increased non-adherence, which has the opposite effect on the costs. Finally, MDIs are facing a new round of drug formulation in order to replace their HFAs with more environmentally friendly propellants and for DPIs, more extra-fine drug particle formulations and dual-excipient formulations for existing active substances can be expected.

14.6 Inhaler Performance, Choice, Instruction and Error Use

14.6.1 General Introduction

For an effective pulmonary therapy, a proper choice has to be made for the active substance or active substance combination and its delivery system. As will become clear from the following paragraphs, the efficacy depends on three different aspects:

- The performance of the inhaler system regarding the aerosol generation and delivery,
- The compliance with the instructions for correct inhaler use and correct inhalation,
- The adherence to the therapy

Compliance and adherence depend on the patient's willingness and ability to use the inhaler correctly. It is important for improvement of the compliance that the errors in inhaler use and those in the inhalation manoeuvre are considered and evaluated separately. They are closely related to the patient's satisfaction with the inhaler system and the burden of inhalation. The burden involves many different aspects, including the number and complexity of the inhaler preparation steps, the time needed for the inhalation, the portability of the inhaler, etc. Compliance and adherence also strongly depend on the relationship with the healthcare professional, the manner in which the instructions are given and the trust in the therapy and in the inhaler system used.

14.6.2 Inhaler Performance

Giving a detailed comparative evaluation of the *in vitro* performance of pulmonary delivery systems in a single paragraph is impossible. There exist simply too many inhalers to describe them all. The same is true for all *in vivo* deposition and effect studies with pulmonary drug delivery systems. Their list is almost infinite. Besides, as will become clear

from the next three paragraphs, the success of the therapy depends in many cases more strongly on the patient's attitude towards correct and consistent inhaler use than on inhaler performance, although there exist inhaler systems that are better not used when there are alternatives. Figure 14.17 compares delivered lung doses and oropharyngeal depositions from *in vivo* deposition studies with radiolabelled medicines for the three different categories of DPIs, MDIs and nebulizers.

Figure 14.17 confirms that on average the differences in lung deposition (black sectors) between modern DPIs and modern MDIs are small. The difference is more extreme

a Drypowder inhalers

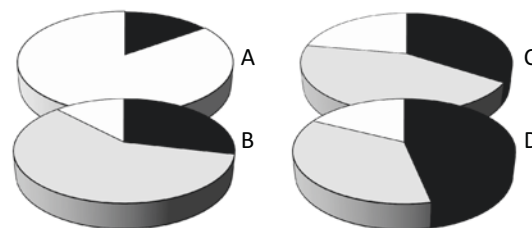

b Metered dose inhalers

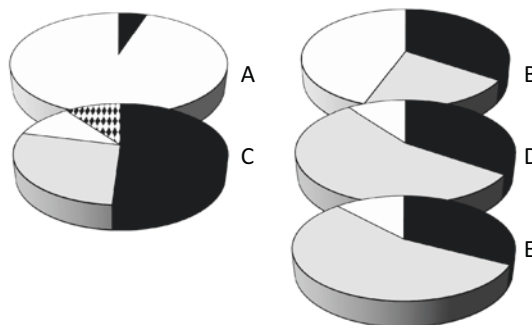

c Nebulizers

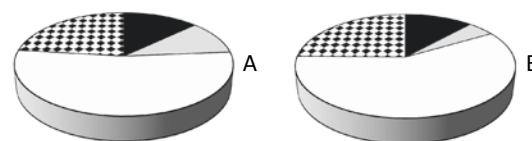

Fig. 14.17 Delivered lung doses (black sectors) and oropharyngeal depositions (grey sectors, as percent of label claim or metered dose) compared between DPIs, MDIs and nebulizers. White sectors are non-delivered (inhaler and/or VHC) residues and dotted sectors are fractions exhaled (usually not measured for DPIs). Data derived from different scintigraphic studies. **(a)** Dry Powder inhalers (DPIs): A is for some first-generation devices (mean of HandiHaler, Pulvinal and Ultrahaler); B for some multi-dose reservoir inhalers (mean of Taifun, Novolizer, Genuair, Turbuhaler and Clickhaler); C for the Podhaler with PulmoSphere tobramycin particles (TOBI) and D for the NEXThaler FDC with extra-fine particles and a force control agent (magnesium stearate). **(b)** Metered dose inhalers (MDIs): A is representative for meanwhile replaced MDIs containing CFC propellant and B for CFC-MDIs with VHCs (mean of Nebuhaler, Volumatic and Nebuchamber). C is for an MDI containing HFA propellant with extra-fine particles; D for an MDI based on co-suspension delivery technology and E for an MDI based on Modulite technology. **(c)** Nebulizers: A is a jet nebulizer without breath activation (Pari LC Plus with TOBI) and B a vibrating mesh (Pari eFlow rapid with TOBI)

between old (DPI:A and MDI:A) and new devices (DPI:B-C and MDI: D-E) of both categories. The increase in delivered fine particle doses over the past 50 years is shown by de Boer and Thalberg [44]. The data in Fig. 14.17 also suggest that Pulmosphere Technology (DPI:C) and extrafine particles (DPI:D) can increase the lung deposition from DPIs significantly, but it needs to be understood that the lung deposition for multi-dose reservoir inhalers (DPI:B) is the mean of different currently marketed inhalers that show great differences in performance between them. Great differences between comparable DPIs are also shown in Fig. 14.10 which compares the *in vitro* deposition data for ICS from the (fixed-dose combination products) Symbicort Turbuhaler, Seretide Diskus and Rolenium Elpenhaler at three different pressure drops. The most relevant size fractions (1–3 μm) from these DPIs differ on average almost by a factor 4 between the Turbuhaler and Elpenhaler and by a factor 2 between the Diskus and Elpenhaler. Moreover, the Turbuhaler is the only device delivering significantly more fine particles (1–3 μm) when the flow rate is increased to compensate (at least partially) for the higher oropharyngeal deposition too. In addition, the Turbuhaler has the highest resistance to air flow, yielding a flow rate of only 59 L/min at 4 kPa versus 76 L/min for the Diskus and 69 L/min for the Elpenhaler. Fine particle fractions for the bronchodilator from these DPIs show nearly the same trend.

Nearly all lung deposition fractions from the better multi-dose reservoir DPIs and most HFA-containing MDIs, whether or not they have been prepared using special technologies, lie within the range from approximately 30–50% of the label claim. This is much higher than those from nebulizers (Fig. 14.17c). Therefore, and taking the burden of the patient in consideration as well, nebulizers should not be prescribed when there is an alternative in a DPI or MDI, providing that the patient can manage using the MDI or DPI correctly.

14.6.3 Inhaler Choice

As will be surveyed in Sect. 14.6.4, the error frequency in inhaler use is generally extremely high. There are different reasons for it and it is of utmost importance to make a good assessment of the risks of poor compliance and adherence when selecting an inhaler for the patient. The high error frequency confirms that the patient plays a critical role in the inhalation process. The patient has part in establishing the desirable conditions for the administration, which includes both correct inhaler handling and a correct inhalation manoeuvre. Poor compliance with either (or both) of these prerequisites, results in a higher morbidity and higher hospital admission rates, poorer quality of life and a higher risk factor for premature mortality [162].

Generally, two factors dominate the patient preference and incidence rate of incorrect use for a particular device. They are the skills of the patient and certain key attributes of the inhalation system. All three types of pulmonary drug administration systems, nebulizers, MDIs and DPIs, have their own specific benefits and disadvantages that can have an influence on the compliance and adherence. It may be clear that nebulization is not the preferred administration technique for adult patients at home, unless there is no alternative in an MDI or DPI. Nebulization is laborious and time-consuming, varying from a few minutes (for vibrating mesh nebulizers) up to 10 or 15 min for jet nebulizers. This is without the preparation procedures and regular cleaning (and disinfection) of the equipment. Nebulizers are also relatively large devices that are difficult to take out and they need to be connected to the mains, unless they are powered by batteries. For all these aspects that have a negative effect on the adherence of the therapy, the use of nebulizers for non-hospitalised patients is unwanted. Therefore, they will not further be discussed in this paragraph.

Based on the foregoing considerations, the first step in the decision making for an appropriate inhalation system is to assess the ability and motivation of the patient to adhere to the inhalation protocol. To assist with the first step in the selection procedure the scheme in Fig. 14.18 can be used. The scheme shows which type of delivery system may be considered for patients when they are, or when they are not able to understand and/or comply with all necessary steps of correct inhaler handling and an adequate inhalation manoeuvre for lung deposition. The latter includes for DPIs and MDIs (including the Respimat) a deep exhalation prior to inhaling the aerosol followed by a deep inhalation with the aerosol and a breath hold period of at least 5 to (preferably) 10 s to facilitate sedimentation deposition in the most distal airways. Particularly the MAYBEs require special attention of the instructors, as they depend very much on particular inhaler complexity regarding the handling steps to perform and the specific impairments of individual patients.

It is often mentioned that patients with a poor lung function are unable to generate a sufficiently high flow rate through a high resistance DPI [e.g., 163]. Therefore, it is recommended that they use a low resistance device. This is not correct however. Being able to generate a higher pressure drop across a higher resistance is the same for healthy subjects and patients with an impaired lung function. Therefore, the question whether to use a high or low resistance DPI depends rather on other clinical signs of the impairment, such as shortness of breath, a high breathing rate and a high residual volume.

		DEVICES	POOR	POOR	POOR
			COORDINATION	MOTOR SKILLS	COGNITIVE SKILLS
INSPIRATORY CAPACITY	HIGH	HR DPI MDR	YES	MAYBE	MAYBE
		HR DPI CAP	YES	MAYBE	MAYBE*
	LOW	LR DPI MDR	YES	MAYBE	MAYBE
		LR DPI CAP	YES	MAYBE	MAYBE*
		BAI MDI	YES	MAYBE	YES
		SMI	MAYBE	YES	MAYBE
		MDI	NO	YES	MAYBE
		MDI + VHC	YES	MAYBE	NO
		VMN (+AAD)	YES	NO	NO
		JET NEB	YES	NO	NO

Fig. 14.18 Decision scheme based on four criteria: inspiratory capacity, hand-lung coordination, motor skills and cognitive skills. A 'NO' means that the inhaler system mentioned left on the same line is most likely not suitable for a patient with the disability indicated on top of the column. Inhalers per category (categories are high and low inspiratory capacity) are listed in order of preference (from top to bottom) regarding ease of use by the patient and lung deposition efficiency. HR is for high resistance, LR for low resistance, MDR for multi-dose reservoir (including multiple single-dose), CAP is for capsules, BAI for breath

actuated inhaler, SMI for soft mist inhaler (Respimat), VMN for vibrating mesh nebuliser. All other abbreviations have been used throughout the text of the chapter. Some MAYBEs may become a YES after practicing has revealed that sufficient skills are available, some NOs may become a YES when inhalation is performed under supervision, or with the help of a supervisor only

*For absent-minded and disorganised users of capsule inhalers it should be ascertained that the risk of confusing oral capsules with inhalation capsules is excluded

When having to choose between DPIs and/or MDIs different aspects may be relevant. Various studies on DPIs and MDIs have confirmed that a large number of handling steps is associated with a higher frequency of critical patient errors [e.g., 33]. Also patients using more than one device with different instructions make more errors [164] and this can become more significant at high age and with poor education status [95, 165, 166]. Hence, age and cognitive skills are important decision parameters in choosing an appropriate inhaler. Additionally, disease-related constraints of motor skills as for instance in Parkinson's disease [167] and rheumatoid arthritis [168] should be reasons not to prescribe inhalers that require dexterity to prepare them for an inhalation. Likewise, impaired [e.g., 169] or immature lung function [e.g., 170] exclude strenuous inhalation manoeuvres. Patients may furthermore not understand that rotating inhaler parts against each other (e.g., Turbuhaler), opening a cap (e.g., NEXTHaler), moving a handle (e.g., Diskus), or pressing a button (e.g., Genuair and various puncturing mechanisms for capsule inhalers) needs to be completed to the end points. In fact, they may not even notice that they did not reach the end point when movement becomes slightly hindered by friction due to some pollution from wasted powder. Various other actions may be critical too and require extra fine motor skills, like inserting dose compartments (e.g., for the Elpenhaler), or muscle power when closing moisture protecting hoods (e.g., for the Podhaler).

Inspiratory and cognitive limitations are often the reason why pre-school children cannot operate most dry powder inhalers effectively [95, 171]. Their peak flow rates may be insufficient and inhaled volumes too low to achieve good powder dispersion and delivery of the whole dose respectively.

14.6.4 Inhaler and Inhalation Errors and Instruction

It has been postulated that management of a chronic airway disease is 10% medication and 90% education [172]. Education includes teaching patients to handle their inhalers correctly and perform the desired inhalation technique for the inhaler used. Although these percentages can be argued, it is irrefutably true that well designed inhalation systems can show poor efficacies when they are not used correctly. Hundreds of scientific manuscripts have been written about correct and incorrect inhaler use and the estimated levels of knowledge among patients using the inhalers, as well as among the health care workers prescribing them. In spite of this abundance of information, error percentages remain worryingly high, largely due to the fact that the precise working principles of the pulmonary delivery devices is often not known by the prescribers. The high incidence of patient errors depends not only on patient factors however. The

design of the inhalation device may have considerable influence too. Inhalers with an intuitive design are less prone to being used incorrectly. Handling steps that require remembering or thinking about how, or in what order to do them correctly, need to be avoided.

For a proper assessment of errors made in pulmonary drug delivery, it is very important to discriminate between inhaler and inhalation errors. Unfortunately, a difference between making errors with the preparation and use of a specific device and (nonspecific) inhalation errors is not always made. Some general inhalation errors like not exhaling before, respectively forgetting a breath-hold after inhalation have been recorded as specific DPI or MDI errors [e.g., 164, 173, 174]. Also, different definitions for the critical inhaler errors are used. Usmani et al. [95] reviewed 114 manuscripts, abstracts and conference proceedings on the subject and reported 299 different descriptions for critical errors varying between the studies. As a result of the diversity in definitions for the critical errors, a high level of heterogeneity is obtained between studies. Lavorini et al. [76] reviewed 47 studies on inhalation errors and found error percentages for incorrect inhaler technique varying as much as from 4% to 94% for the Turbuhaler, 4–68% for the Diskhaler, 8–49% for the Diskus and 21–67% for the Rotahaler between studies. In spite of this heterogeneity, Crystyn et al. [33] computed from a systematic literature review (using 72 studies) overall error rates (for at least one error) of 87% for MDIs and 61% for DPIs. Their rates for at least one critical error were lower and respectively 46% for MDIs and 28% for DPIs. Lavorini et al. [76] referred to 76% of patients making at least one error when using an MDI but Melani et al. [165] showed an opposite result with only 12% critical errors for MDIs versus 34,5; 35 and 43,4% for the Diskus, HandiHaler and Turbuhaler DPIs respectively. The situation of high error rates has not changed over the past 40 years as concluded by Sanchis et al. [175] who extracted nearly 60.000 observations from 144 manuscripts published between 1975 and 2014. They computed mean error percentages of 45% for poor coordination, 44% with speed and/or depth of inspiration and 46% for not holding the breath after inhalation when using an MDI. In comparison they found 29% for incorrect preparation, 46% for omitting to exhale prior to inhalation and 37% for not holding the breath after inhalation when using a DPI. They also found no significant difference in percentages between the period from 1975 to 1994 and the period from 1995 to 2014. The overall prevalence of correct technique in their review was found to be only 31%.

Regardless of these differences in outcome, a considerable number of MDI or DPI users are making inhaler and inhalation errors, meaning that significant improvement is possible. There are several reasons for the high error rate percentages. Various studies have confirmed that differences in the operating instructions between DPIs confuse patients

that use multiple inhalers. In some studies, more than 50% of patients use at least two different inhalers and 10% even use three different devices [e.g., 174]. This, and switching from one device to another contributes to making handling errors [e.g., 164]. Zhang et al. [176] concluded from a comprehensive systematic literature study that it also leads to a low adherence rate with the therapy. They referred to economic analyses showing that multiple inhaler therapies are associated with increased healthcare resource use and low cost-effectiveness. This increases the health-economic burden [95] and it has been suggested that matching the device to the patient is an even better course of action for improving inhaler technique than training and retraining a patient to use a specific inhaler device [98]. A regular assessment of inhaler device use is also recommended by global COPD treatment guidelines to improve long-term clinical outcomes [177]. Confusing for the patient is also having two versions of the same DPI with two different resistance values on the market. The Spiromax Aerivo (with fluticasone and salmeterol) has a low resistance similar to that of the Diskus, whereas the Spiromax DuoResp (with budesonide/formoterol) has a high resistance similar to that of the Turbuhaler.

The worryingly high inhaler error percentages may partly also be blamed on lack of knowledge among healthcare professionals. It is not enough knowing how to prepare and use the inhalation system and how to inhale best through the apparatus, but also why to follow these prescriptions. Without this knowledge, the consequences of incorrect use and inhalation cannot be explained and this is at the cost of the instructor's credibility. A good patient-instructor relationship based on faith and trustworthiness has a positive influence on the adherence [162]. Various studies have confirmed that there is an insufficient number of medical professionals having the proper knowledge and skill to teach inhaler technique correctly. Plaza et al. [178] reviewed 55 studies on the inhalation technique knowledge of health care professionals from the period between 1975 and 2014. They computed an overall correct technique from all studies of only 15.5% and observed that this percentage decreases with time (from 20.5% for the period between 1975 and 1995 to 10.8% between 1996 and 2014). This decrease may at least partly be the result of an increased number of different inhalers on the market with different operation procedures since 1995. This makes pulmonary drug delivery more complex and it has been recommended that the industry improves on the lack of uniformity by developing a standardized method of delivery across all inhalation systems in order to reduce confusion [179]. Plaza et al. [178] also mentioned the most frequent errors with MDIs and DPIs, of which two from the top three lists were the same for both systems: not breathing out before inhalation (75% and 79% for MDIs and DPIs respectively) and not holding the breath post-inhalation (63% and 76% for MDIs and DPIs respectively). These two are not

errors with the inhaler handling, but inhalation errors. They have no relationship with the inhaler concept or design, in contrast with an overall mean lack of coordination (64% for MDIs) and deficient inhaler preparation (89% for DPIs). Although these figures are highly indicative for the poor quality of inhalation instruction to patients, they should not be considered absolute. Extreme differences between studies exist and the outcomes may have been shaded by incorrect assumptions due to a lack of knowledge by the investigators too. For instance, a forceful inhalation through DPIs, as often prescribed in studies on DPI technique [e.g., 178, 180], may not be optimal for a DPI as this depends on the inhaler resistance, the powder dispersion efficacy and the drug emission pattern. Therefore, recording a less forceful inhalation as erroneous may for some DPIs be an error in itself. There appear to be great differences in the mean level of knowledge between different groups of healthcare specialists, and also within these groups [e.g., 179, 180]. Alismail et al. [179] tested the theoretical instruction knowledge for the use of four different inhaler systems and computed scores between 40% and 85% for respiratory therapists (mean is 70%), 50–100% for pharmacists (mean is 78%), 30–80% for registered nurses (mean is 61%) and 40–75% for physicians (mean is 54%) respectively. They also concluded that intervention with a video presentation is ineffective in improving the knowledge. This, in contrast with a 2-h face-to-face workshop. Healthcare professionals having a greater knowledge of asthma, e.g., by personal use of asthma devices, or more years of experience in asthma care, appear to score better in questionnaires about inhalation instruction [180]. Striking, however, is the observation in various studies that healthcare personnel are aware of the existence of instruction guidelines but fail to use these [e.g., 181, 182].

Striking is also the lack of improvement that can be obtained for certain errors. Taylor et al. [183] concluded for MDIs that inadequate actuation-inhalation coordination and inhaling too fast (> 90 L/min) are the most frequently made errors with this type of inhaler. They contributed to 97% registered error use (for at least one critical error) before tuition, versus 89% after tuition from an expert clinical reviewer. This is an improvement by only 8%. This can be explained by the fact that coordination involves a complex combination of different skills and requires special training programs for improvement, whereas the patient has no reference for the flow rate to aim at. Such, and other data suggest, that good instruction without proper practise, is unlikely to significantly improve inhaler technique [98]. It should also be mentioned that the information that can be derived from the scientific literature for DPIs contains persistent misconceptions about the best inhalation manoeuvre through this type of pulmonary delivery device. Many articles still recommend rapid and forcible inhalation, or fastest possible inhalation through DPIs [e.g., 98, 184] in order to create sufficient tur-

bulent energy [e.g., 94]. This kind of generalisation does not contribute to a better understanding of the working principle of DPIs and neither to optimisation of the therapy. Finally, it has been recognised that some patients, knowing very well how to use their inhaler system correctly and having the understanding why, and competence to do so, contrive to use it in an alternative and suboptimal manner, thereby frustrating their therapy [e.g., 162]. Psychosocial and educational interventions [e.g., 185] or motivational interviewing [e.g., 186], may be needed to achieve some improvement in this respect, as has been shown in other studies striving to change habits and behaviours [187].

Different instruction methods are available to improve the inhalation technique by the patient. They vary from enhanced face-to-face training session(s) and multi-media delivered training to using inhalation technique feedback devices. Normansell et al. [188] reviewed 29 studies using one of these techniques and concluded for adults that enhanced education benefits from face-to-face training with follow-up session(s) and from using feedback devices (also with a follow-up evaluation), but the effect of multimedia training is uncertain. They also found it difficult to recommend how clinicians can most effectively intervene if they find a patient's technique inadequate at a follow-up meeting. Very few devices currently have a mechanical feedback system and they provide scarce information about the inhalation manoeuvre. Several new electronic monitoring systems are in development, or have recently become available. Devices like the Turbu+ (previously referred to as SmartTurbo monitor) are for use on the AZ Turbuhaler [189]. The same technology is also applied under the name Propeller for MDIs and the Breezhaler DPI. The system does not measure flow manoeuvre parameters, in contrast with the Respiro platform from Amiko, but records only inhaler use and is primarily meant to improve the adherence to the therapy. It corresponds with a smartphone for the storage of data. A review on the use of electronic monitoring devices (EMDs) with evidence for their positive effect on the adherence and some other outcomes is known from Blakey et al. [190].

Also correct handling of the inhaler must be trained and critically observed by the instructor. All marketed inhalation devices are delivered with instruction manuals that include a section entitled 'how to use this device'. In most cases, the successive steps described in these manuals are correct, and better than generalised instructions that can be found on the internet for different groups of devices. However, instruction manuals do not all show illustrations for all the individual steps to take and this may lead to an incorrect understanding of 'how precisely'. They also make use of phrases that enable different interpretations, such as 'inhale forcefully', or 'inhale quickly and deeply'. Terms like these do not provide absolute quantification of the strength and duration for the inhalation exercise and are

open for personal understanding. Besides, most instruction manuals do not explain why complying with some of the prescribed steps is important, such as avoiding exhalation through the inhaler, or holding the breath for 5–10 s. Knowing why often leads to a better compliance and it is the task of the instructor to inform the patient about these ‘whys’.

Summarising the highlights of instruction which are basically, the same for DPIs, MDIs and the Respimat:

1. Prepare the inhaler according to the instructions
2. Sit upright, straighten the back and look slightly upwards
3. Exhale deeply, with the face turned away from DPIs
4. Inhale deeply (to total lung capacity), applying mild to moderate inspiratory effort
5. Hold the breath for preferably 10 s before exhaling
6. Rinse the mouth, if necessary

For DPIs, it is important that:

- The inhaler is held in the correct position during dose activation and inhalation,
- The dose activation mechanism (handle, knob, etc.) is displaced to its end point. For some mechanisms also subsequent displacement to the starting position is required (e.g., capsule piercing knobs must not block capsule movement during inhalation)
- No violent inhaler movements are made after dose activation
The air inlet slots are not blocked during inhalation
- The inhaler is gently displaced towards the mouth after dose activation and exhaling
- The inhaler is stored at a dry and cool place (not in the refrigerator: this may cause condensation on the cold inhaler surfaces)
- The patient knows which DPI to shake before use, and which ones definitely not
- DPIs are not treated violently and shocks (as from falling) are prevented
- Inhalers are not wetted (e.g., by washing them)

For MDIs, it is important that:

- The patient has good hand-lung coordination. This must be checked by the instructor
- The MDI is shaken before use according to the instructions keeping the MDI in the same position as during inhalation (it is better to do this for all MDIs, irrespective of whether the active substance is in suspension or in solution)
- The time between MDI shaking and inhalation is as short as possible
- No more doses are derived from the inhaler than indicated on the label

- The MDI is not exposed to high temperature or great temperature changes
- Patients are aware of the possibility of loss of prime. In case of doubt, dose delivery must be checked by firing a dose in the air
- Anti-static VHCs are used or static VHCs are primed before using them. For some anti-static VHCs additional drip drying may be necessary to achieve optimal drug output
- The time between firing a dose into the VHC and inhaling the aerosol is as short as possible

Questions

1. Some scientific manuscripts present values for the MMADs of aerosols from inhalation systems without additional information in order to show how they perform. Give at least three arguments why this is meaningless.
2. What is adaptive aerosol delivery (AAD) and for what type of pulmonary delivery system is it applicable?
3. What advice should be given to a patient who exhaled accidentally through a dry powder inhaler?
4. What are the possible consequences for the therapy when the jet flow from the hospital's compressed air system through a nebuliser is increased to shorten the nebulisation time?
5. What are the consequences of clogging of the perforated membrane of a vibrating mesh nebulizer?
6. Are two dry powder inhalers that deliver the same fine particle dose of the same active substance by definition equivalent in terms of therapeutic efficacy, or can they be different? If so, what are the differences?
7. What can be done by the healthcare expert to increase the compliance with the instructions for correct inhaler use and inhalation, and to improve the adherence to the therapy?

References

1. Hinds WC (1982) Aerosol technology. Properties, behavior, and measurement of airborne particles. Wiley, New York
2. DeHaan WH, Finlay WH (2001) *In vitro* monodisperse aerosol deposition in a mouth and throat with six different inhalation devices. *J Aerosol Med* 14:361–367
3. DeHaan WH, Finlay WH (2004) Predicting extrathoracic deposition from dry powder inhalers. *J Aerosol Sci* 35:309–331
4. Myrdal PB, Seth P, Stein SW (2014) Advances in metered dose inhaler technology: formulation development. *AAPS PharmSciTech* 15:434–455
5. Solkane HFA 227 pharma and 134a pharma propellant datasheet. <https://www.daikinchem.de/sites/default/files/pdf/Propellants/Daikin%20Propellants%20-%20Solkane%20227,%20134a%20pharma.pdf>. Accessed Dec 2021

6. Gupta A, Stein SW, Myrdal PB (2003) Balancing ethanol cosolvent concentration with product performance in 134a-based pressurized metered dose inhalers. *J Aerosol Med* 16:167–174
7. Chierici V, Cavallieri L, Piraino A et al (2020) Consequences of not-shaking and shake-fire delays on the emitted dose of some commercial solution and suspension pressurized metered dose inhaler. *Expert Opin Drug Deliv* 17:1025–1039
8. Hatley RHM, Parker J, Prichard JN, von Hollen D (2017) Variability in delivered dose from pressurized metered-dose inhaler formulations due to a delay between shake and fire. *J Aerosol Med Pulm Drug Deliv* 30:71–79
9. Stein SW, Sheth P, David Hodson P, Myrdal PB (2014) Advances in metered dose inhaler technology: hardware development. *AAPS PharmSciTech* 15:326–338
10. Conner JB, Buck PO (2013) Improving asthma management: the case for mandatory inclusion of dose counters on all rescue bronchodilators. *J Asthma* 50:658–663
11. Lewis DA, O’Shea H, Mason F, Church TK (2017) Exploring the impact of formulation and temperature shock on metered dose priming. *Aerosol Sci Technol* 51:84–90
12. Price D, Bosnic-Anticevich S, Briggs A et al (2013) Inhaler competence in asthma: common errors, barriers to use and recommended solutions. *Respir Med* 107:37–46
13. Lavorini F, Barreto C, van Boven JFM et al (2020) Spacers and valve holding chambers – the risk of switching to different chambers. *J Allergy Clin Immunol* 8:1569–1573
14. Dissanayake S, Suggett J (2018) A review of the *in vitro* and *in vivo* valved holding chamber (VHC) literature with a focus on the AeroChamber Plus flow-vu anti-static VHC. *Ther Adv Respir Dis* 12:1–14
15. Kenyon CJ, Thorsson L, Borgström L, Newman SP (1998) The effects of static charge in spacer devices on glucocorticosteroid aerosol deposition in asthmatic patients. *Eur Respir J* 11:606–610
16. De Vries TW (2008) Improving care in paediatric asthma: patients, prescriptions, pharmacovigilance, pathogens, and particles. Thesis University of Groningen, Faculty of Science and Engineering. ISBN 9789036735384
17. Hagedoorn P, Bawary W, Frijlink HW, Grasmeijer F (2020) A comparative analysis of changes in pMDI drug dose delivery before and after detergent coating using five antistatic valved holding chambers. *J Allergy Clin Immunol Pract* 8:1124–1125e1–e4
18. Rottier BL (2012) Improving drug delivery to the lungs: towards better inhalation therapy. Thesis University of Groningen, Faculty of Medical Science. ISBN 9789081988803
19. Liu X, Guo C, Chowdhury B et al (2017) Valved holding chambers and *in vitro* metered dose inhaler performance: effects of flow rate and inhalation delay. *J Aerosol Med Pulm Drug Deliv* 30:1–12
20. Csonka P, Tapiainen T, Mäkelä MJ, Lethimäki L (2021) Optimal administration of bronchodilators with valved holding chambers in preschool children: a review of literature. *Eur J Pediatr* 180:3101–3109
21. Esposito-Festen JE, Ates B, van Vliet FJM et al (2004) Effect of a facemask leak on aerosol delivery from a pMDI-spacer system. *J Aerosol Med* 17:1–6
22. Janssens HM, Tiddens HAWM (2007) Facemasks and aerosol delivery by metered dose inhaler – valved holding chamber in young children: a tight seal makes the difference. *J Aerosol Med* 20(Suppl 1):S59–S63; discussions S63–S65
23. Barry PW, O’Callaghan C (1999) The output of budesonide from spacer devices assessed under simulated breathing conditions. *J Allergy Clin Immunol* 104:1205–1210
24. Janssens HM, Krijgsman A, Verbraak TFM et al (2004) Determining factors of aerosol deposition for four pMDI-spacer combinations in an infant upper airway model. *J Aerosol Med* 17:51–61
25. Amirav I, Newhouse MT (2008) Review of optimal characteristics of face-masks for valved-holding chambers (VHCs). *Pediatr Pulmonol* 43:268–274
26. Sander N, Fusco-Walkert SJ, Harder JM, Chipps BE (2006) Dose counting and the use of pressurized metered-dose inhalers: running on empty. *Ann Allergy Asthma Immunol* 97:34–38
27. Rubin BK, Lolly D (2004) How do patients determine that their metered-dose inhaler is empty? *Chest* 126:1134–1137
28. Brock TP, Wessell AM, Williams DM, Donoue JF (2002) Accuracy of float testing for metered-dose inhaler canisters. *J Am Pharm Assoc* 42:582–586
29. Given J, Taveras H, Iverson H, Lepore M (2013) Prospective, open-label assessment of albuterol sulfate hydrofluoroalkane metered-dose inhaler with new integrated dose counter. *Allergy Asthma Proc* 34:42–51
30. Connor JB, Buck PO (2013) Improving asthma management: the case for mandatory inclusion of dose counters on all rescue bronchodilators. *J Asthma* 50:658–663
31. Ganderton D, Lewis D, Meakin B, Brambilla G, Church T (2002) Modulite®: a means of designing the aerosols generated by pressurized metered dose inhalers. *Respir Med* 96:53–58
32. Dellamary LA, Tarara TE, Smith DJ et al (2000) Hollow porous particles in metered dose inhalers. *Pharm Res* 17:168–174
33. Chrystyn H, van der Palen J, Shama R et al (2017) Device errors in asthma and COPD: systematic literature review and meta-analysis. *Prim Care Respir Med* 27:22. <https://doi.org/10.1038/s41533-017-0016-z>
34. Lavorini F (2013) The challenge of delivering therapeutic aerosols to asthma patients. *ISRN Allergy:Article ID 102418: 1–17*. <https://doi.org/10.1155/2013/102418>
35. Gabrio BJ, Stein SW, Velazquez DJ (1999) A new method to evaluate plume characteristics of hydrofluoroalkane and chlorofluorocarbon metered dose inhalers. *Int J Pharm* 186:3–12
36. Brambilla G, Church T, Lewis D, Meakin B (2011) Plume temperature emitted from metered dose inhalers. *Int J Pharm* 405:9–15
37. Versteeg HK, Hargrave GK, Myatt BJ et al (2017) Using phase doppler anemometry and high-speed imaging to analyze MDI spray plume dynamics. *Respir Drug Deliv Eur*:129–142. <https://hdl.handle.net/2134/24258>. Accessed Feb 2022
38. Zhu B, Traini D, Young P (2014) Aerosol particle generation from solution-based pressurized metered dose inhalers: a technical overview of parameters that influence respiratory deposition. *Pharm Dev Technol*, Early online: 1–14. <https://doi.org/10.3109/108374502014.959176>
39. Gavtash B, Myatt B, O’Shea H et al (2015) Saturated vapour pressure (SVP) measurement of ethanol/HFA binary mixtures. *Drug Deliv Lungs* 26. <https://ddl-conference.com/ddl26-2015/conferencepapers/saturated-vapour-pressure-svp-measurement-ethanolhfa-binary-mixtures/>
40. Lewis DA, O’Shea H, Johnson R, Church TK (2011) Predicting HFA-MDI dose retention properties: engineering the marriage between canisters, valves and formulations. *Respir Drug Deliv Eur*:89–100. <https://www.researchgate.net/publication/273129682>. Accessed Feb 2022
41. Lewis DA, O’Shea H, Mason F, Church TK (2017) Exploring the impact of formulation and temperature shock on metered dose inhaler priming. *Aerosol Sci Technol* 51:84–90
42. Crompton G (2006) A brief history of inhaled asthma therapy over the last fifty years. *Prim Care Respir J* 15:326–331
43. Stein SW, Thiel CG (2017) The history of therapeutic aerosols: a chronological review. *J Aerosol Med Pulm Drug Deliv* 30:21–41
44. de Boer AH, Thalberg K (2021) Dry powder inhalers (DPIs). In: Kassinos S, Bäckman P, Conway J, Hickey AJ (eds) *Inhaled medicines. Optimizing development through integration of in silico, in vitro and in vivo approaches*. Elsevier/Academic

45. Staniforth JN (1987) British pharmaceutical conference science award lecture: order out of chaos. *J Pharm Pharmacol* 39:329–334
46. Hersey JA (1975) Ordered mixing; a new concept in powder mixing practice. *Powder Technol* 11:41–44
47. Podczeczek F, Newton JM, James MB (1997) Influence of relative humidity of storage air on the adhesion and autoadhesion of micronized particles to particulate and compacted powder surfaces. *J Colloid Interface Sci* 187:484–491
48. de Boer AH, Chan HK, Price R (2012) A critical view on lactose-based drug formulation and device studies for dry powder inhalation: which are relevant and what interactions to expect? *Adv Drug Deliv Rev* 64:357–274
49. Grasmeyer F, Grasmeyer N, Hagedoorn P, Frijlink HW, de Boer AH (2015) Recent advances in the fundamental understanding of adhesive mixtures for inhalation. *Curr Pharm Des* 21:5900–5914
50. de Boer AH, Hagedoorn P, Gjaltema D et al (2004) The mode of drug particle detachment from carrier crystals in an air classifier-based inhaler. *Pharm Res* 21:2167–2174
51. Sibum I, Hagedoorn P, de Boer AH et al (2018) Challenges for pulmonary delivery of high powder doses. *Int J Pharm* 548:325–336
52. Albertson TE, Bowman WS, Harper RW (2019) Evidence-based review of data on the combination umeclidinium/vilanterol in patients with COPD. *Int J Chron Obstruct Pulmon Dis* 14:1251–1265
53. Tashkin DP, Ohar JA, Koltun A, Allen R, Ward JK (2021) The role of ICS/LABA fixed-dose combinations in the treatment of asthma and COPD: bioequivalence of a generic fluticasone propionate-salmeterol device. *Pulm Med*:article ID 8881895. <https://doi.org/10.1155/2021/8881895>
54. Grant AC, Walker R, Hamilton M, Garrill K (2015) The ELLIPTA® dry powder inhaler: design, functionality, in vitro dosing performance and critical task compliance by patients and caregivers. *J Aerosol Med Pulmon Drug Deliv* 28:474–485
55. Liu S, Watts AB, Bui A et al (2015) Formulation of a novel fixed dose combination of salmeterol and mometasone furoate for inhaled drug delivery. *Eur J Pharm Biopharm* 96:132–142
56. Corradi M, Chrystyn H, Cosio BG et al (2014) NEXThaler, an innovative dry powder inhaler delivering an extrafine fixed combination of beclomethasone and formoterol to treat large and small airways in asthma. *Expert Opin Drug Deliv* 11:1497–1506
57. Begat P, Morton DAV, Shur J et al (2009) The role of force control agents in high-dose dry powder inhaler formulations. *J Pharm Sci* 96:2770–2783
58. Trofast EA-C, Olsson M, Ahlneck C (2002) Agglomeration of finely divided powders US-patent 637171
59. Yang TT, Kenyon D (2000) Use of an agglomerate formulation in a new multidose dry powder inhaler. In: Dalby RN, Byron PR, Farr SJ, Peart J (eds) *Respiratory drug delivery VII*. Serentec Press, Raleigh, pp 503–505
60. Wetterlin K (1988) Turbuhaler: a new powder inhaler for administration of drugs to the airways. *Pharm Res* 5:506–508
61. Boerefijn R, Ning Z, Ghadiri M (1998) Disintegration of weak agglomerates for inhalation applications. *Int J Pharm* 172:199–208
62. Tonnis WT, Lexmond AJ, Frijlink HW, de Boer AH, Hinrichs WLJ (2013) Devices and formulations for pulmonary vaccination. *Expert Opin Drug Deliv* 10:1383–1397
63. Geller DE, Weers J, Heuerding S (2011) Development of an inhaled dry-powder formulation of tobramycin using PulmoSphere™ technology. *J Aerosol Med Pulm Drug Deliv* 4:175–182
64. Conole D, Keating GM (2014) Colistimethate sodium dry powder for inhalation: a review of its use in the treatment of chronic *Pseudomonas aeruginosa* infection in patients with cystic fibrosis. *Drugs* 74:377–387
65. Grosset DG, Dhall R, Gurevich T et al (2020) Inhaled levodopa in Parkinson's disease patients with OFF periods: a randomized 12-month pulmonary safety study. *Parkinsonism Relat Disord* 71:4–10
66. Gil E, Garcia-Alonso F, Boldenau A, Teixeira TB (2018) Safety and efficacy of self-administered inhaled loxapine (ADASUVE) in agitated patients outside the hospital setting: protocol for a phase IV, single-arm, open-label trial. *BMJ Open* 8:e020242. <https://doi.org/10.1136/bmjopen-2017-020242>
67. Heinemann L (2008) The failure of Exubera: are we beating a dead horse? *J Diabetes Sci Technol* 2:518–529
68. Murugappan S, Patil HP, Kanojia G et al (2013) Physical and immunogenic stability of spray freeze-dried influenza vaccine powder for pulmonary delivery: comparison of inulin, dextran or a mixture of dextran and trehalose as protectants. *Eur J Pharm Biopharm* 85:716–725
69. Edwards DA, Hanes J, Caponetti G et al (1997) Large porous particles for pulmonary drug delivery. *Science* 276:1868–1871
70. Duddu SP, Sisk SA, Walter YH et al (2002) Improved lung delivery from a passive dry powder inhaler using an engineered PulmoSphere® powder. *Pharm Res* 19:689–695
71. Vehring R (2008) Pharmaceutical particle engineering via spray drying. *Pharm Res* 25:999–1022
72. Ferrari F, Cocconi D, Bettini R et al (2004) The surface roughness of lactose particles can be modulated by wet-smoothing using a high-shear mixer. *AAPS PharmSciTech* 5:article 60. <http://www.aapspharmscitech.org>
73. Weers JG, Miller DP (2015) Formulation design of dry powders for inhalation. *J Pharm Sci* 104:3259–3288
74. Bell JH, Hartley PS, Cox JSG (1971) Dry powder aerosols I: a new powder inhalation device. *J Pharm Sci* 60:1559–1564
75. Buttini F, Quarta E, Allegrini C, Lavorini F (2021) Understanding the importance of capsules in dry powder inhalers. *Pharmaceutics* 13:1936. <https://doi.org/10.3390/pharmaceutics13111936>
76. Lavorini F, Magnan A, Dubus JC et al (2008) Effect of incorrect use of dry powder inhalers on management of patients with asthma and COPD. *Respir Med* 102:593–604
77. Gregoriano C, Dieterle T, Breitenstein A-L (2018) Use and inhalation technique of inhaled medication in patients with asthma and COPD: data from a randomized controlled trial. *Respir Res* 19:237. <https://doi.org/10.1186/s12931-018-0936-3>
78. Milillo P, Riccio D, Di Perna L et al (2017) Wearable improved vision system for color vision deficiency correction. *Ophthalmology* 5:3800107
79. Mira JJ, Lorenzo S, Guilabert M, Navarro I, Pérez-Jover V (2015) A systematic review of patient medication error on self-administering medication at home. *Expert Opin Drug Saf* 14:815–838
80. Martinelli F, Balducci A, Rossi A et al (2015) “Pierce and inhale” design in capsule based dry powder inhalers: effect of capsule piercing and motion on aerodynamic performance of drugs. *Int J Pharm* 487:197–204
81. van Renswouw DC, van Laarhoven ACM, van Haren M, Bouvy M, Weda M (2010) Storage instructions for inhalation capsules: consequences of incorrect storage and adherence in daily practice. *J Pharm Pract* 23:548–562
82. Birchall JC, Jones BE, Morrissey A, Jones BE (2008) A comparison of puncturing properties of gelatin and hypromellose capsules for use in dry powder inhalers. *Drug Dev Ind Pharm* 24:870–876
83. Elkins MR, Robinson P, Anderson SD (2014) Inspiratory flows and volumes in subjects with cystic fibrosis using a new dry powder inhaler device. *Open Respir Med J* 8:1–7
84. Al-Tabakha M (2010) HPMC capsules: current status and future prospects. *J Pharm Pharm Sci* 13:428–442
85. Wauthoz N, Hennis I, Ecenarro S, Amighi K (2018) Impact of capsule type on aerodynamic performance of inhalation products: a case study using a formoterol-lactose binary or ternary blend. *Int J Pharm* 553:47–56
86. Benke E, Varga P, Szabó-Révész P, Ambrus R (2021) Stability and in vitro aerodynamic studies of inhalation powders containing ciprofloxacin hydrochloride applying different DPI

- capsule types. *Pharmaceutics* 13:689. <https://doi.org/10.3390/pharmaceutics13050689>
87. van der Palen J, van der Valk P, Goosens M et al (2013) A randomised cross-over trial investigating the ease of use and preference of two dry powder inhalers in patients with asthma or chronic obstructive pulmonary disease. *Expert Opin Drug Deliv* 10:1171–1178
 88. Schreiber J, Sonnenburg T, Luecke E (2020) Inhaler devices in asthma and COPD patients – a prospective cross-sectional study on inhaler preferences and error rates. *BMC Pulm Med* 20:222. <https://doi.org/10.1186/s12890-020-01246-z>
 89. Luinstra M, Isufi V, de Jong T et al (2019) Learning from Parkinson's patients: usability of the Cyclops dry powder inhaler. *Int J Pharm* 567:118493. <https://doi.org/10.1016/j.ijpharm.2019.118493>
 90. Chrystyn H (2007) The Diskus™: a review of its position among dry powder inhaler devices. *Int J Clin Pract* 61:1022–1036
 91. Canonica GW, Arp J, Keegstra JR, Chrystyn H (2015) Spiromax, a new dry powder inhaler: dose consistency under simulated real-world conditions. *J Aerosol Med Pulm Drug Deliv* 28:309–319
 92. Calvert G, Ghadiri M, Tweedle R (2009) Aerodynamic dispersion of cohesive powders: a review of understanding and technology. *Adv Powder Technol* 20:4–16
 93. Benque B, Khinast JG (2019) Understanding the motion of hard-shell capsules in dry powder inhalers. *Int J Pharm* 567:118481. <https://doi.org/10.1016/j.ijpharm.2019.118481>
 94. Laube BL, Janssens HM, de Jongh FHC et al (2011) What the pulmonary specialist should know about the new inhalation therapies. *Eur Respir J* 37:1308–1331
 95. Usmani OS, Lavorini F, Marshall J et al (2018) Critical inhaler errors in asthma and COPD: a systematic review of impact on health outcomes. *Respir Res* 19:10. <https://doi.org/10.1186/s12931-017-0710-y>
 96. Ng D, Kerwin EM, White MV et al (2020) Clinical bioequivalence of Wixela Inhub and Advair Diskus in adults with asthma. *J Aerosol Med Pulm Drug Deliv* 33:99–107
 97. Donohue JF, Burgoyne DS, Ward JK et al (2021) Wixela Inhub: a generic equivalent treatment option for patients with asthma or COPD. *Pulm Ther* 7:47–57
 98. Haughney J, Price D, Barnes NC et al (2010) Choosing inhaler devices for people with asthma: current knowledge and outstanding research needs. *Respir Med* 3:125–131
 99. Janssens W, VandenBrande P, Hardeman E et al (2008) Inspiratory flow rates at different levels of resistance in elderly COPD patients. *Eur Respir J* 31:78–83
 100. Mahler DA (2017) Peak inspiratory flow rate as criterion for dry powder inhaler use in chronic obstructive pulmonary disease. *Ann Am Thorac Soc* 14:1103–1107
 101. Kohler D (2004) The Novolizer®: overcoming inherent problems of dry powder inhalers. *Respir Med* 98(Suppl A):S17–S21
 102. Lechuga-Ballesteros D, Noga B, Vehring R et al (2011) Novel cosuspension metered dose inhalers for the combination therapy of chronic obstructive pulmonary disease and asthma. *Future Med Chem* 3:13
 103. McCallion ONM, Taylor KMG, Thomas M, Taylor AJ (1995) Nebulization of fluids of different physicochemical properties with air-jet and ultrasonic nebulizers. *Pharm Res* 12:1682–1688
 104. Harvey CJ, O'Doherty MJ, Page CJ (1997) Comparison of jet and ultrasonic nebulizer pulmonary aerosol deposition during mechanical ventilation. *Eur Respir J* 10:905–909
 105. Heidmann MF, Priem RJ, Humphrey JC (1957) A study of sprays formed by two impinging jets, NACA technical notes, report 3835. National Advisory Committee Aeronautics. <https://digital.library.unt.edu/ark:/67531/metadc56084/>
 106. Li R, Ashgriz N (2006) Characteristics of liquids sheets formed by two impinging jets. *Phys Fluids* 18:087104. <https://doi.org/10.1063/1.2338064>
 107. van Hoeve W, Gekle S, Snoeijer JH et al (2010) Breakup of diminutive Rayleigh jets. *Phys Fluids* 22:122003. <https://doi.org/10.1063/1.3524533>
 108. Fu H, Patel AC, Holtzman MJ, Chen D-R (2011) A new electro-spray aerosol generator with high particle transmission efficiency. *Aerosol Sci Technol* 45(10):1176–1183
 109. Gupta R, Hindle M, Byron PR, Cox KA, McRae DD (2003) Investigation of a novel condensation aerosol generator: solute and solvent effects. *Aerosol Sci Technol* 37(8):672–681
 110. Werley MS, Miller JH, Kane DB et al (2016) Prototype e-cigarette and the capillary aerosol generator (CAG) comparison and qualification for use in subchronic inhalation exposure testing. *Aerosol Sci Technol* 50(12):1284–1293
 111. Udey RN, Jones AD, Farquar GR (2013) Aerosol and microparticle generation using a commercial inkjet printer. *Aerosol Sci Technol* 47(4):316–372
 112. Usmani OS, Biddiscombe MF, Barnes PJ (2005) Regional lung deposition and bronchodilator response as a function of beta2-agonist particle size. *Am J Respir Crit Care Med* 172:1497–1504
 113. Lalo H, Leclerc L, Sorin J, Pourchez J (2020) Aerosol droplet-size distribution and airborne nicotine partitioning in particle and gas phase emitted by electronic cigarettes. *Nat Res* 10:23707. <https://doi.org/10.1038/s41598-020-78749-6>
 114. Mercer TT (1981) Production of therapeutic aerosols: principles and techniques. *Chest* 80(Suppl):813–818
 115. Ramisetty KA, Pandit AB, Cogate PR (2013) Investigations into ultrasound induced atomization. *Ultrason Sonochem* 20:254–264
 116. Yeo LY, Friend JR, McIntosh MP (2010) Ultrasonic nebulization platforms for pulmonary drug delivery. *Expert Opin Drug Deliv* 7:663–679
 117. O'Callaghan C, Barry PW (1997) The science of nebulised drug delivery. *Thorax* 52(Suppl 2):S31–S44
 118. Hede PD, Bach P, Jensen AD (2008) Two-fluid spray atomisation and pneumatic nozzles for fluid bed coating/agglomeration purposes: a review. *Chem Eng Sci* 63:3821–3842
 119. Martin AR, Finlay WH (2015) Nebulizers for drug delivery to the lungs. *Expert Opin Drug Deliv* 12:889–900
 120. Hess DR (2000) Nebulizers: principles and performance. *Respir Care* 45:609–622
 121. Steckel H, Eskandar F (2003) Factors affecting aerosol performance during nebulization with jet and ultrasonic nebulizers. *Eur J Pharm Sci* 19:443–455
 122. McCallion ONM, Taylor KMG, Bridges PA, Thomas M, Taylor AJ (1996) Jet nebulizers for pulmonary drug delivery. *Int J Pharm* 130:1–11
 123. Myers D (1990) Surfaces, interfaces and colloids. Principles and applications. VHC Verlagsgesellschaft mbH, Weinheim, pp 217–279
 124. Ari A (2014) Jet, ultrasonic, and mesh nebulizers: an evaluation of nebulizers for better clinical outcomes. *Eurasian J Pulmonol* 16:1–7
 125. Rau JL, Ari A, Restrepo R (2004) Performance comparison of nebulizer designs: constant-output, breath-enhanced, and dosimetric. *Respir Care* 49:174–179
 126. Kendrick AH, Smith EC, Denyer J (1995) Nebulizers – fill volume, residual volume and matching of nebulizer to compressor. *Respir Med* 89:157–159
 127. Hess D, Fischer D, Williams P, Pooler S, Kacmarek RM (1995) Medication nebulizer performance. Effects of diluent volume, nebulizer flow and nebulizer brand. *Chest* 110:498–505

128. Buttini F, Rossi I, Di Cuia M et al (2016) Combinations of colistin solutions and nebulizers for lung infection management in cystic fibrosis patients. *Int J Pharm* 502:242–248
129. Standaert TA, Bohn SE, Aitkin ML, Ramsey B (2001) The equivalence of compressor pressure-flow relationships with respect to nebulizer aerosolization characteristics. *J Aerosol Med* 14:31–42
130. Newman SP, Pellow PGD, Clarke SW (1987) *In vitro* comparison of DeVilbiss jet and ultrasonic nebulizers. *Chest* 92:991–994
131. de Boer AH, Hagedoorn P, Frijlink HW (2003) The choice of a compressor for the aerosolization of tobramycin (TOBI®) with the PARI LC PLUS® reusable nebuliser. *Int J Pharm* 268:59–69
132. Westerman EM, de Boer AH, Touw DJ et al (2008) Aerosolization of tobramycin (TOBI®) with the PARI LC PLUS® reusable nebulizer: which compressor to use? Comparison of the CR60® to the PortaNeb® compressor. *J Aerosol Med Pulm Drug Deliv* 21:269–280
133. Cohen J, Postma DS, Douma WR et al (2011) Particle size matters: diagnostics and treatment of small airways involvement in asthma. *Eur Respir J* 37:532–540
134. Alvine GF, Rodgers P, Fitzsimmons KM, Ahrens RC (1992) Disposable jet nebulizers. How reliable are they? *Chest* 101:316–319
135. Chemmalasseri EA (2012) Numerical modelling of droplet formation in mesh nebulizers. Thesis technical, University Delft, the Netherlands. <https://repository.tudelft.nl/islandora/object/uuid%3A16a442ae-05ea-4b35-817f-3239131b0bac>
136. Lass JS, Sant A, Knoch M (2006) New advances in aerosolised drug delivery: vibrating membrane nebuliser technology. *Expert Opin Drug Deliv* 3:693–702
137. Olszewski OZ, MacLoughlin R, Blake A (2016) A silicon-based MEMS vibrating mesh nebulizer for inhaled drug delivery. *Proc Eng* 168:1521–1524
138. Carvalho T, McConville JT (2015) The function and performance of aqueous aerosol devices for inhalation therapy. *J Pharm Pharmacol* 68:556–578
139. Gowda AA, Cuccia AD, Smaldone GC (2017) Reliability of vibrating mesh technology. *Respir Care* 62:65–69
140. Pritchard JN, Hatley RHM, Denyer J, von Hollen D (2018) Mesh nebulizers have become the first choice for new nebulized pharmaceutical drug developments. *Ther Deliv* 9:121–136
141. Rottier BL, van Erp CJP, Sluyter TS et al (2009) Changes in performance of the Pari eFlow® rapid and Pari LC Plus™ during 6 months use by CF patients. *J Aerosol Med Pulm Drug Deliv* 22:263–269
142. Lin H-L, Chen C-S, Fink JB et al (2020) In vitro evaluation of a vibrating-mesh nebulizer repeatedly use over 28 days. *Pharmaceutics* 12(10):971. <https://doi.org/10.3390/pharmaceutics1210971>
143. Dalby RN, Eicher J, Zierenberg B (2011) Development of RespiMat® soft mist™ inhaler and its clinical utility in respiratory disorders. *Med Devices Evid Res* 1(4):145–155
144. Zierenberg B (1999) Optimizing the in vitro performance of RespiMat. *J Aerosol Med* 12(Suppl 1):S19–S24
145. Iwanaga T, Tohda Y, Nakamura S, Suga Y (2019) The RespiMat® Soft Mist inhaler: implications of drug delivery characteristics for patients. *Clin Drug Investig* 39:1021–1030
146. Navaie M, Dembek C, Cho-Reyes S, Yeh K, Celli BR (2020) Device use errors with soft mist inhalers: a global systematic literature review and meta-analysis. *Chron Respir Dis* 17:1–13
147. Hodder R, Price D (2009) Patient references for inhaler devices in chronic obstructive pulmonary disease: experience with RespiMat® Soft Mist inhaler. *Int J COPD* 4:381–390
148. Longest W, Spence B, Hindle M (2019) Devices for improved delivery of nebulized pharmaceutical aerosols to the lungs. *J Aerosol Med Pulm Drug Deliv* 32:317–339
149. Dhand R (2010) Intelligent nebulizers in the age of the internet: the I-neb Adaptive Aerosol Delivery (AAD) System. *J Aerosol Med Pulm Drug Deliv* 23(Suppl 1):III–V
150. Denyer J, Dyche T (2010) The Adaptive Aerosol Delivery (AAD) technology: past, present, and future. *J Aerosol Med Pulm Drug Deliv* 23(Suppl 1):S1–S10
151. Bennett WG (2005) Controlled inhalation of aerosolised therapeutics. *Expert Opin Drug Deliv* 2:763–767
152. Fischer A, Stegemann J, Scheuch G, Siekmeier R (2009) Novel devices for individualized controlled inhalation can optimize aerosol therapy in efficacy, patient care and power of clinical trials. *Eur J Med Res* 14(Suppl IV):71–77
153. Berlinski A (2014) Effect of mask dead space and occlusion of mask holes on delivery of nebulized albuterol. *Respir Care* 59:1228–1232
154. Healan AM, Gray W, Fuchs EJ et al (2012) Stability of colistimethate sodium in aqueous solution. *Antimicrob Agents Chemother* 56:7432–7433
155. Castilhos JK, Dillenburg TL, Autunes MV et al (2020) Evaluation of the stability of Polymoxin B in saline and glucose solutions using LC-MS/MS. *Braz J Pharm Sci* 56:e18367. <https://doi.org/10.1590/s2175-97002019000318367>
156. Mann JS, Howard PH, Holgate ST (1984) Bronchoconstriction induced by ipratropium bromide in asthma: relation to hypotonicity. *Br Med J* 289:469
157. Antunes SC, Nunes B, Rodriguez S et al (2016) Effects of chronic exposure to benzalkonium chloride in *Oncorhynchus mykiss*: cholinergic neurotoxicity, oxidative stress, peroxidative damage and genotoxicity. *Environ Toxicol Pharmacol* 45:115–122
158. Preparations for inhalation, European Pharmacopoeia (2019) 10th edition, 04/2018:0671, pp. 927–928
159. Kamin W, Schwabe A, Krämer I (2006) Inhalation solutions – which one are allowed to be mixed? Physico-chemical compatibility of drug solutions in nebulizers. *J Cyst Fibros* 5:205–213
160. Burchett DK, Darko W, Zahra J et al (2010) Mixing and compatibility guide for commonly used aerosolized medications. *Am J Health Syst Pharm* 67:227–230
161. Beckard IB, Asimakis P, Bertolini J, Sunstan DE (2011) The effects of shear flow on protein structure and function. *Biopolymers* 95:733–745
162. Ari A (2015) Patient education and adherence to aerosol therapy. *Respir Care* 60:941–957
163. Chen SY, Huang C-K, Peng H-C et al (2020) Inappropriate peak inspiratory flow rate with dry powder inhaler in chronic obstructive pulmonary disease. *Nat Sci Rep* 10:7271. <https://doi.org/10.1038/s41598-020-64235-6>
164. van der Palen J, Klein JJ, van Herwaarden CLA et al (1999) Multiple inhalers confuse asthma patients. *Eur Respir J* 14:1034–1037
165. Melani AS, Bonavia M, Cilenti V et al (2011) Inhaler mishandling remains common in real life and is associated with reduced disease control. *Respir Med* 105:930–938
166. Barbara S, Kritikos V, Bosnic-Anticevich S (2017) Inhaler technique: does age matter? A systematic review. *Eur Respir Rev* 26(146):170055. <https://doi.org/10.1183/16000617.0055-2017>
167. van Puymbroeck M, Walter A, Hawkins BL et al (2018) Functional improvements in Parkinson's disease following a randomized trial of yoga. *Evid Based Complement Alternat Med*:article ID 8516351. <https://doi.org/10.1155/2018/8516351>
168. Steultjens EEMJ, Dekker JJ, Bouter LM et al (2004) Occupational therapy for rheumatoid arthritis (review). *Cochrane Database Syst Rev* 2004(1):art no. CD003114. <https://doi.org/10.1002/14651858.CD003114.pub2>
169. Marklund S, Bui K-L, Nyberg A (2019) Measuring and monitoring skeletal muscle function in COPD: current perspectives. *Int J Chron Obstruct Pulmon Dis* 14:1825–1838

170. Lexmond AJ, Kruizinga TJ, Hagedoorn P et al (2014) Effect of inhaler design variables on paediatric use of dry powder inhalers. *PLoS One* 9(6):e99304. <https://doi.org/10.1371/journal.pone.0099304>
171. Lexmond AJ, Hagedoorn P, Frijlink HW, Rottier BL, de Boer AH (2017) Prerequisites for a dry powder inhaler for children with cystic fibrosis. *PLoS One* 12(8):e0183130. <https://doi.org/10.1371/journal.pone.0183130>
172. Fink JB (2005) Inhalers in asthma management: is demonstration the key to compliance? *Respir Care* 50:598–600
173. Castel-Branco MM, Fontes A, Figueredo V (2017) Identification of inhaler technique errors with a routine procedure in Portuguese community pharmacy. *Pharm Pract* 15(4):1072. <https://doi.org/10.18549/PharmPract.2017.04.1072>
174. Lindh A, Theander A, Arne M et al (2019) Errors in inhaler use related to devices and to inhalation technique among patients with chronic obstructive pulmonary disease in primary health care. *Nurs Open* 6:1519–1527
175. Sanchis J, Gich I, Pederen S (2016) Systematic review of errors in inhaler use. Has patient technique improved over time? *Chest* 150:394–406
176. Zhang S, King D, Rosen V, Ismaila AS (2014) Impact of single combination inhaler versus multiple inhalers to deliver the same medications for patients with asthma or COPD: a systematic literature review. *Int J Chron Obstruct Pulmon Dis* 15:417–438
177. D'Urzo A, Chapman KR, Donohue JF (2019) Inhaler devices for delivery of LABA/LAMA fixed-dose combinations in patients with COPD. *Pulm Ther* 5:23–41
178. Plaza V, Giner J, Rodrigo GJ (2017) Errors in the use of inhalers by healthy care professionals: a systematic review. *J Allergy Clin Immunol Pract* 6:987–995
179. Alismail A, Song CA, Terry MH et al (2016) Diverse inhaler devices: a big challenge for health-care professionals. *Respir Care* 61:593–599
180. Basheti IA, Hamadi SA, Reddel HK (2016) Inter-professional education unveiling significant association between asthma knowledge and inhaler technique. *Pharm Pract* 14(1):713. <https://doi.org/10.18549/PharmPract.2016.01.713>
181. O'Donnell J, Birkinshaw R, Burke V, Driscoll PA (1997) The ability of A & E personnel to demonstrate inhaler technique. *J Accid Emerg Med* 14:163–164
182. Nakajima T, Nagano T, Suraya R et al (2020) A questionnaire survey of the inhalation instruction in pharmacies. *Kobe J Med Sci* 66(3):E113–E118
183. Taylor TE, Zigel Y, Egan C et al (2018) Objective assessment of patient inhaler user technique using an audio-based classification approach. *Nat Sci Rep* 8:2164. <https://doi.org/10.1038/s41598-018-20523-w>
184. Azouz W, Chrystyn H (2012) Clarifying the dilemmas about inhalation techniques for dry powder inhalers: integrating science with clinical practice. *Prim Care Respir J* 21:208–213
185. Chamberlain C, Mara-Eves A, Coleman PJ et al (2017) Psychosocial interventions for supporting woman to stop smoking in pregnancy (review). *Cochrane Database Syst Rev* 2:art no. CD001055. <https://doi.org/10.1002/14651858.CD001055.pub5>
186. Latchford G, Duff A, Quinn J, Conway S, Conner M (2009) Adherence to nebulised antibiotics in cystic fibrosis. *Patient Educ Couns* 75:141–144
187. Heydari G, Masiedi M, Abmady AE et al (2014) A comparative study on tobacco cessation methods: a qualitative systematic review. *Int J Prev Med* 5:673–678
188. Normansell R, Kew KM, Mathioudakis AG (2017) *Cochrane database. Syst Rev* 3:art no. CD012286. <https://doi.org/10.1002/14651858.CD012286.pub2>
189. Pilcher J, Shirtcliffe P, Patei M (2015) Three-month validation of a Turbuhaler electronic monitoring device: implications for asthma clinical trial use. *BMJ Open Respir Res* 2:e000097. <https://doi.org/10.1136/bmjresp-2015-000097>
190. Blakey JD, Bender BG, Dima AL et al (2018) Digital technologies and adherence in respiratory diseases: the road ahead. *Eur Respir J* 52:1801147. <https://doi.org/10.1183/13993003.01147-2018>