

Fatigue life prediction of turbine blades with geometric imperfections made of stainless steel

Makgwantsha Hermelton MASHIACHIDI ^{*}, Dawood A. DESAI 

Faculty of Engineering and the Built Environment, Tshwane University of Technology, Pretoria, South Africa
^{*}Corresponding author: 212200816@tut4life.ac.za

Keywords

geometric variation
low-pressure
finite element analysis
fe-safe
fatigue failure
stainless steel
material properties

Abstract

This research addresses critical challenges faced by steam turbine blades, particularly in low-pressure (LP) turbines, where premature failures are common due to stress concentrations at the blade root area. The study introduces a numerical methodology aimed at predicting the life of mistuned steam turbine blades, with a focus on variations in blade geometry which have received limited exploration in existing literature. A simplified, scaled-down mistuned steam turbine bladed disc model was developed using Abaqus finite element software. Acquisition of steady-state stress response of the disc models was performed through finite element analysis (FEA). Thereafter, numerical stress distributions were obtained. Subsequently, within *Companion* software, a Monte Carlo simulation-based probabilistic approach was applied to evaluate and quantify uncertainties in fatigue life for 17 cases. This analysis considered an accepted manufacturing percentage scatter of $\pm 5\%$ for the steam turbine bladed disc. That was conducted by selecting mistuning (geometry variation) percentages as the random variables. The methodology demonstrated reliability, correlating well with literature-based and discrete fatigue life results. This study establishes the potential for accurately predicting the fatigue life of mistuned steam turbine blades using the developed methodology.

History

Received: 12-09-2023
Revised: 30-10-2023
Accepted: 31-10-2023

1. Introduction

Geometric deviations in steam turbine blades introduce uncertainties that impact performance. Therefore, it affects the working conditions of the entire steam turbine component. Rieger [1] discusses the design and optimisation methods of steam turbine blades are deterministic, therefore the approached method for life prediction is both probabilistic methodology development and deterministic. It is focused on blade edges and surface roughness.

Previous study by Zhang et al. [2] have shown that fatigue most often results in cracks and fractures at the blade root structure during consistent operating conditions. Fatigue is the process of accumulated damages due to the presence of cyclic stresses.

Every component that is subjected to alternating stress and loading experiences fatigue. The studied method was unable to predict the fatigue life.

Fatigue is identified as one of the leading damage mechanisms that cause significant losses. Fatigue in turbine blades is classified as either high cycle fatigue (HCF) or low cycle fatigue (LCF). According to Rieger [1], LCF is usually associated with fewer load cycles of much larger strain range, corrosion or high temperature reported. HCF is commonly associated with moderate mean stress levels and high dynamic stresses.

HCF describes the fatigue cycles in a range of 10^4 to 10^8 occurrences reported by Zhang et al. [2]. HCF damage accumulation happens over 10.000 cycles as highlighted by Booysen et al. [3]. For each startup and shutdown, the number of cycles of vibratory loads gets accumulated and may cause fatigue failure noted by Booysen et al. [3]. Hence HCF is used in this study.

 This work is licensed under a Creative Commons Attribution-NonCommercial 4.0 International (CC BY-NC 4.0) license

Research conducted by Rao and Vyas [4] found that dynamic stresses are influenced by the magnitude and source of the excitation, blade damping and the degree of the turbomachinery blade geometrical mistuning. As highlighted by Schönleitner et al. [5], dimensional imperfections and deviations are due to the tolerances and manufacturing process, material inhomogeneity and in-service wear. These deviations lead to structural mistuning and can increase the forced response vibration amplitude which increases HCF. This is commonly called mistuning. It affects the blade geometric variations which lead to mistune of the blade's natural frequencies which affect the entire steam turbine component. Due to the geometric blade variation, mistuning cannot be ignored when coupling exists among the blades.

In the realm of steam turbine blade materials, ASTM 304 stainless steel emerges as a prominent choice due to its widespread utilisation. Renowned for its remarkable ductility, this material proves particularly advantageous for blades subjected to substantial centrifugal and bending loads within steam turbines. The intrinsic ductile nature of ASTM 304 stainless steel facilitates a nuanced plastic deformation at the root contact, thereby enhancing the distribution of loads. This property holds significant implications for preventing failures and cracks, as underscored by findings reported in the study by Schönleitner et al. [5]. Consequently, the selection of ASTM 304 stainless steel as the focal material for this investigation is rooted in its tailored characteristics to address the critical challenges associated with steam turbine blade performance. This paper delves into a comprehensive exploration of the material's behaviour and performance within the specific context of steam turbine applications.

The martensitic stainless steel X22CrMoV12-1 (DIN 1.4923) chosen for characterising the LP blades is a prevalent option in Eskom power stations reported by Booyesen et al. [3]. This specific steel variant is widely employed in LP turbine casings and blades owing to its outstanding strength and resistance to corrosion, making it well-suited for the challenging environmental conditions within steam turbines. It is noteworthy to mention that, although not selected for the current investigation, the material discussed here is a modified version derived from high-temperature grade steel X20CrMoV12-1 that was extensively used in various applications within steam power plants during the early 1960s. This

information is provided as insight into an additional potential material that merits consideration for future studies or applications.

Yan et al. [6] investigated the vibration mechanism of a mistuned bladed disc using the natural frequencies and mode shapes of the bladed disc. They found that the natural frequency of a mistuned bladed disc is denser and has a wider scatter compared to that of the tuned harmonious one. A study conducted by Yan et al. [6] of natural frequencies on tuned and mistuned bladed discs indicates that more resonance may occur in the mistuned bladed disc. The results of Yan et al. study found that the mode shape of the tuned bladed disc is either regularly distributed in cosine wave or the constant, but the mode shape of the mistuned bladed disc is very anomalous. Furthermore, they concluded that the mode shapes of the mistuned bladed disc are characterised by extremely large amplitudes in a few blades. These blades certainly have the most risk of fatigue failure.

Research conducted by Liao et al. [7] illustrates a technique to determine the maximum amplification of the steady-state forced response of steam turbine bladed discs due to mistuning. The authors suggested an optimisation strategy which moderates mistuned bladed discs and considers them as physical approximations of the worst-case disc. Thereafter, the mistuned properties are pursued to maximise the response of a specific steam turbine blade. In their study, Liao et al. [7] observed distribution peak amplitudes ranging from 0.87504 to 1.8301 across an occurrence number spectrum from 0 to 1250.

2. Mathematical modelling

This section serves as a review of the relevant basic mathematical theories used to calculate the HCF life of mistuned turbomachinery blades. Various contributing stresses, i.e. mean and alternating stresses, to the HCF were determined for the specific working conditions (pressure and rotational speed) of the steam turbine. Pressure and rotational speed are the essence of this research to understand how stress affects the fatigue life under operational working conditions. Thereafter, the Brown-Miller algorithm and the Dang Van multiaxial criterion are introduced and mathematically formulated for the calculation of the mistuned blade's fatigue life (crack initiation and propagation). Lastly, relevant statistical studies

are introduced for the determination and development of appropriate probabilistic fatigue life simulation models.

2.1 Life calculation using finite element method

The study in this work is a simplified disc with 8 blades. For life prediction of a steam turbine bladed disc, the FEM is the most effective engineering tool and has been used in many scientific-practical works in the turbine engineering area. The blade structure is rigidly fixed on the disc rim.

The dynamic load in newtons (N) from the partial supply of steam can be defined as in Equation (1) by Booyesen et al. [3]

$$F = \frac{2P \sin(\nu \mu \pi)}{\pi \nu}, \quad (1)$$

where ν is the excitation harmonic, μ is the distance between the blades, P is the aerodynamic pressure and F is the force exerted by air or gas flow on the surface of the steam turbine bladed discs surfaces.

Mukhopadhyay et al. [8] propose that a rotational speed of 3000 rpm is necessary for a steam turbine operating at 50 Hz. The 3rd harmonic of the excitation frequency corresponds to 150 Hz, and the 4th harmonic is at 200 Hz. Notably, the 4th harmonic is the sum of the 50 Hz operational frequency and the harmonic excitation frequency. Figure 1 depicts the application of a constant pressure load on the surfaces of steam turbine bladed discs.

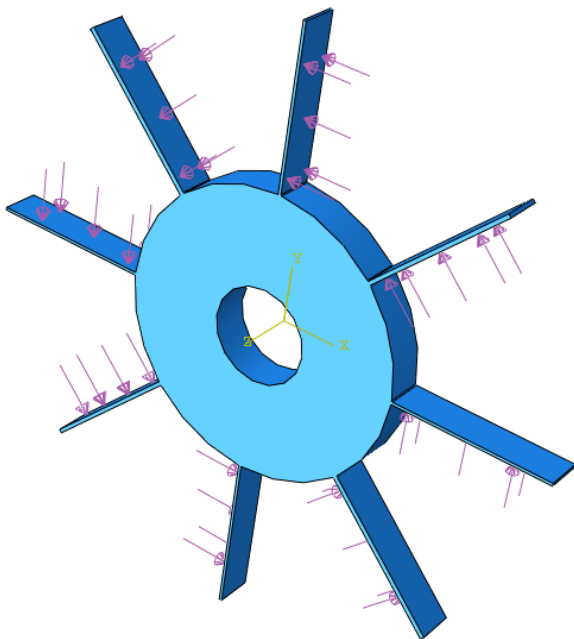

Figure 1. Constant pressure load on steam turbine bladed disc surface

2.2 Statistical analysis and probability

This part represents the background section on the application of statistics and probabilities in fatigue life prediction. Uncertainties and variabilities are present on a daily basis in the engineering field which cannot be ignored. Statistics and probabilities can be useful tools for defining and computing the uncertainties in data, input, and output. The aim is to define the probabilistic fatigue life model of the mistuned steam turbine blades subjected to variation in blade geometry caused by the uncertainty and variability of the geometry of the blades.

Mean and deviation. The present error in the data analysis of blade geometry, amplitude loading or stress distribution within steam turbine blades, can be statistically defined. They can be simplified by computing the mean and standard deviation of the steam turbine geometric blade's variation sample. The mean is the average value and is presented in Equation (2)

$$\mu = \frac{1}{l} \sum_{i=1}^l s_i. \quad (2)$$

where μ is the mean, s_i is the value of each individual in the sample and l is the sample size.

The standard deviation (σ) on how the data is spread out in a distribution and the size of the deviation from the mean is formulated in Equation (3), highlighted by Ross [9]

$$\sigma = \sqrt{\frac{1}{l} \sum_{i=1}^l (s_i - \mu)^2}. \quad (3)$$

Statistical distributions. Due to the large data set, statistical distributions or probability density functions (PDF) are employed. According to Ross [9], out of multiple types of data distributions for variations in key parameters, the normal distribution, also known as the Gaussian distribution is employed. A study by Mofoka [10] presented that the concept mentioned above is the most efficient statistical distribution because of the multiple physical, social and scientific processes that it can model. Normal distribution is defined as a symmetrical bell-shaped curve where the peak occurs at the median or the mean noted by Minitab [11]. The PDF of the normal distribution is given in Equation (4)

$$f(x) = \frac{1}{\sqrt{2\pi}\sigma} \left(\frac{-(x-\mu)^2}{2\sigma^2} \right), \quad \sigma > 0, \quad (4)$$

where μ is the mean, σ^2 is the variance and σ is the standard deviation.

2.3 Blade pass frequency

The blade pass frequency (BPF) refers to the frequency at which the blades of a rotating machine, such as a turbine or compressor, pass a fixed point during each revolution. It is a key parameter in the analysis of machinery vibration and dynamics noted by Kim et al. [12]. Furthermore, BPF is one of the fault frequencies of interest in machine vibration spectra mentioned by Mofoka [10]. The value of the (BPF) is influenced by the number of blades and is quantified by a specific Equation (5)

$$BPF = \frac{Nt}{60}, \quad (5)$$

where BPF is in Hz, N is the rotational speed in rpm and t is the number of blades of the turbomachine.

In this study, the steam turbine model has 8 blades and rotates at a speed of 3000 rpm. Therefore the BPF with substitution of the mentioned variables is calculated as 400 Hz.

3. Numerical modelling

This section describes the development and analysis of an FE model of scaled-down variables simplified mistuned LP steam turbine bladed disc. The analyses used the varied blade geometry and were subjected to a sinusoidal pressure load excitation developed through approximations from the static steam forces with blade pass frequency.

3.1 Model boundary conditions and rotation

The finite element modelling of boundary conditions was initially assigned by applying the rotational constraints to the centre hub surface to prevent axial movements within the simulation. Therefore, a rotational speed of 3000 rpm converted to 314.159 rad/s angular velocity was applied along the centre hub (around the z-direction in Fig. 1).

3.2 Mesh selection

The mesh generation process plays a crucial role in simulation studies as it governs both the computational time of the FE model and the accuracy of the FEA results. In the analysis of the steam turbine bladed disc, the model was meshed using first-order, reduced integration brick elements of the C3D8R type, representing a three-dimensional continuum with homogeneous mass distribution. Consequently, a 1 mm mesh size was chosen as the optimal choice for the blade roots, while the default mesh size was applied to the remainder of the FE model.

3.3 Numerical modelling data

The developed FE model used ASTM 304 stainless steel. The properties of this steel, obtained from Laibi and Shather [13] and Ocaña et al. [14], are presented in Table 1.

Table 1. ASTM 304 stainless steel properties

Property	Value
Tensile strength, MPa	515
Elongation A_{50} , %	40
Hardness (Brinell)	201
Modulus of elasticity, GPa	193
Yield strength, MPa	205
Density, kg/m ³	7896
Poisson's ratio	0.25

Figure 2 illustrates the two-dimensional depictions of the down-sized and simplified model of an 8-bladed disc, with each blade numbered from 1 to 8. The units of measurement in the drawing are original values in mm.

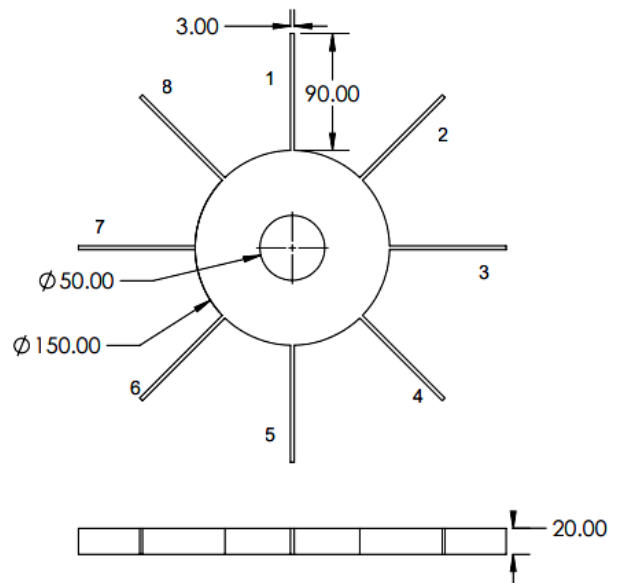

Figure 2. Dimensional steam turbine bladed disc model

4. Results and discussion

4.1 Stress distribution magnitude

In Figure 3 the maximum FE simulation mean stress at blade roots is anticipated as 137.3 MPa. The mathematical centrifugal stress was calculated to be 121.8 MPa by Mashiachidi and Desai [15]. Both stresses are compared to the material yield strength of 205 MPa; thus it can be concluded that no yielding takes place as both the analytical and FE results fall below the maximum yield strength of the material. The mean stress results, which are

depicted in Figure 3, also reveal that the peak stress location is in the blade root spot, which is in agreement with the initial anticipation.

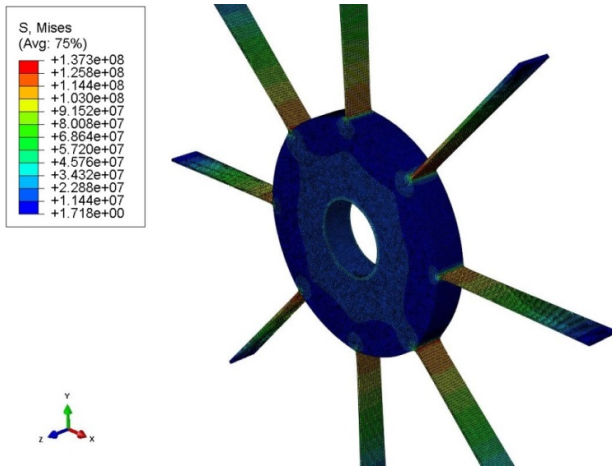

Figure 3. Mean stress (MPa) distribution

4.2 Damping

Damping is one of the key variables that need to be quantified after the boundary conditions to perform the FE steam turbine simulations. The damping ratio is selected to follow the standard distribution adopted from a study by Booyesen et al. [3] of experiment testing results. The damping ratio is a parameter used to quantify the level of damping or energy dissipation in a vibrating or oscillating system. Their damping ratio results range from 0.299 to 0.77 % for the freestanding

steam turbine blades, as illustrated in Figure 1 without applied pressure. The use of a damping ratio of 0.6 % can dissipate the vibration energy in the mistuned blades to limit the dynamic stress that occurs during the operation; hence it is assigned for this study.

4.3 HCF life prediction

This section presents the HCF life prediction with the computed steady-state stress FE model together with the material properties. The *fe-safe* software results for discrete life prediction are compared with the mean of the probability density function of fatigue life mode.

4.4 Fatigue life cycle calculation

Firstly, the used material in this study, ASTM 304 stainless steel is selected from the wide material database of *fe-safe* software as the default material. Then the Brown-Miller multiaxial method was selected as the prescribed HCF life calculation algorithm.

The results discussed by Orsagh and Roemer [16] showed that the scatter of 5 % is considered an accepted tolerance among the blades in the manufacturing industry for LP steam turbine blades. Hence, $\pm 5\%$ was used in the variation of original blade geometries dimensions from Figure 2 which is illustrated in Table 2.

Table 2. Sensitivity of ASTM 304 stainless steel fatigue life cycles to geometric deviation within $\pm 5\%$

Case	Geometric deviation	Fatigue life, cycles
1	Reference (tuned or original) model (90 mm 20 mm 3 mm)	4.587×10^6
14	Decreased blade 1 length (85.5 mm)	4.803×10^6
15	Increased blade 1 width (3.15 mm)	4.397×10^6
16	Decreased blade 1 width (2.85 mm)	4.365×10^6
9	Decreased mixed mistuned pattern blade 1 (85.5 mm 2.85 mm)	4.298×10^6
4	Increased blade width of 2 opposite blades 1 and 5 (3.15 mm)	4.298×10^6
5	Decreased blade width of 2 opposite blades 1 and 5 (2.85 mm)	4.295×10^6
6	Increases mixed mistuned pattern of blades 1 and 5 (94.5 mm 21 mm 3.15 mm)	4.245×10^6
8	Decreased mixed mistuned pattern of blades 1 and 5 (85.5 mm 2.85 mm)	4.221×10^6
3	Decreased blade length of 2 opposite blades 1 and 5 (85.5 mm)	4.217×10^6
10	Decreased mixed mistuned pattern of blade 1 (2.85 mm 19 mm)	4.213×10^6
2	Increased blade thickness of 2 opposite blades 1 and 5 (21 mm)	4.197×10^6
7	Increased mixed mistuned pattern of blade 1 (94.5 mm 3.15 mm)	4.179×10^6
12	Increased blade thickness of 2 opposite blades 1 and 5 (3.15 mm)	4.109×10^6
13	Decreased blade thickness of 2 opposite blades 1 and 5 (2.85 mm)	4.107×10^6
11	Increased mixed mistuned pattern of blade 1 (94.5 mm 21 mm 3.15 mm)	4.065×10^6
17	Decreased mixed mistuned pattern of blade 1 (85.5 mm 19 mm 2.85 mm)	4.043×10^6

The 4.043×10^6 fatigue life cycles result in Figure 4 represent the fatigue life cycles at node 2677 on the blade roots area. These results are obtained by considering blade 1 which is 5 % smaller than the original one (Fig. 4), with dimensions of 85.5 mm (length), 19 mm (thickness) and 2.85 mm (width). The results are presented in Table 2 as case 17.

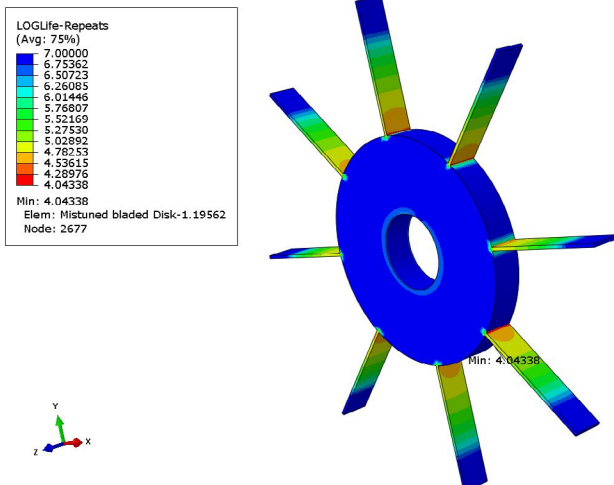

Figure 4. The *fe-safe* fatigue life (cycles) of the mistuned model in case 17

Table 2 illustrates detailed fatigue life cycles resulting from variations in the parameters of length, width and thickness dimensions changed in 17 cases in descending order. The mixed mistuned patterns involve simultaneous alteration of two or three parameters. Table 2 displays a descending sequence of fatigue life cycles, commencing with case 14 with 4.803×10^6 cycles involving length deviation, progressing to case 16 with 4.365×10^6 cycles and concluding with case 17 with 4.043×10^6 cycles. Additionally, it covers the thickness deviation with 4.107×10^6 cycles in case 13. The *fe-safe* software was used to run all 16 cases of the fatigue life models for arbitrary geometric mistuned patterns as shown in Figure 4 and 1 tuned configuration, resulting in a total of 17 cases as illustrated in Table 2.

4.5 Sensitivity analysis

Sensitivity analysis is a systematic process used to assess how changes in length, width and thickness input parameters impact the output or results of a model, simulation and analysis. It helps to understand the sensitivity of the output to variations in the blade geometry parameters and provides valuable insights into which factors have the most significant influence on the outcomes.

Sensitivity analysis has been conducted to assess the reliability analysis outcomes using a

Monte Carlo simulation. The diversity in blade geometry introduces variability in the blade contributing to premature blade failure. According to Ismail et al. [17], Monte Carlo simulation serves as the effective standard for comparing novel calculation theories.

The Monte Carlo simulation procedure involves the following key steps:

- Sampling of random input variables. In this initial step, random input variables are selected to capture the inherent variability within the system.
- Model evaluation in terms of probabilistic fatigue life simulation. Subsequently, the model is evaluated by simulating probabilistic fatigue life, taking into account the sampled input variables.
- Statistical analysis of model output. The final step involves a comprehensive statistical analysis of the model output, providing insights into the reliability and performance characteristics of the system under consideration.

4.6 Probabilistic fatigue life analysis

The life prediction of steam turbine blades is a complex task that requires the use of probabilistic fatigue analysis. Probabilistic fatigue life simulation is a computational approach used to estimate the fatigue life of a component or structure while considering the inherent variability and uncertainty in input parameters. This probabilistic approach takes into account the uncertainties associated with blade geometry for this study. The statistical distribution for the model was used. The probabilistic approach to predict the life of steam turbine blades is by integrating probabilistic fracture mechanics (PFM) with the Monte Carlo simulation method reported by Booyesen et al. [3]. The research by Niu et al. [18] used the probabilistic design methodology to optimise the steam turbine blades. Hence, 17 numbers of random geometric configuration patterns were compiled to acquire a distribution plot for the fatigue lives of a steam turbine.

The results discussed by Tan et al. [19] showed that the mistuning in a bladed disc arises when there is a slight difference between the blades in terms of geometry, mass and material. In this study, the focus is on mistuning due to differences in blades in terms of geometry. The mistuning values are randomly chosen from a set of possible values.

Seventeen random variables assumed to follow the normal distribution have been generated based on $\pm 5\%$ differences. The mistuning degree pertains to the magnitude of differences or deviations among individual dimensions or values within a mechanical or structural system. In the context of this study, it specifically applies to variations in blade geometry.

The generated random mistuning percentages are shown in Figure 5 and were set to follow a normal distribution in Figure 6. From the randomly generated mistuning percentages, a mean and standard deviation, as shown in Table 3, were obtained.

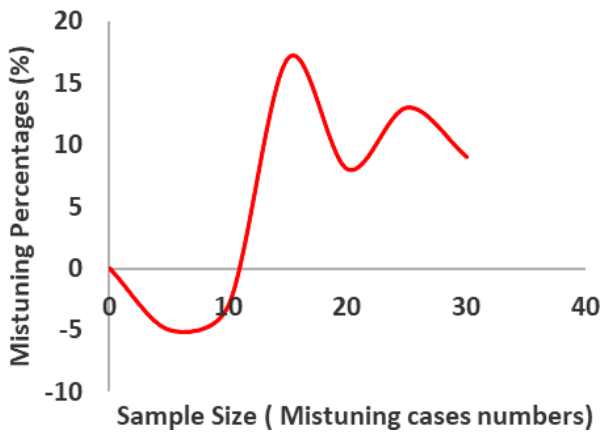

Figure 5. Random distribution plot of mistuning percentage

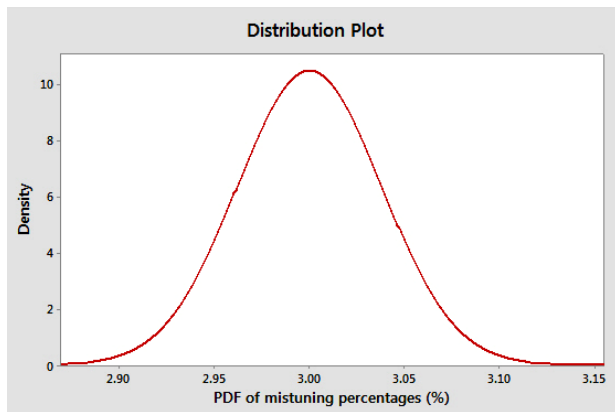

Figure 6. Mistuning degree distribution plot

Table 3. Monte Carlo simulation parameters for variation in geometry

Random variable	Degree of mistuning, %
Mean μ	5
Standard deviation σ	0.0591

The fatigue life cycles were obtained by repeating the fatigue life in *fe-safe* software using the Monte Carlo simulation with variations in blade geometry. The probabilistic fatigue life is

conducted and validated against the seventeen discrete fatigue lives obtained from *fe-safe* software, as presented in Table 4. The discrete fatigue life model focuses on a fixed and defined number of stress cycles that a material or component, in this case ASTM 304 stainless steel, can endure before experiencing failure. This study examines this model within the context of a simplified bladed disc component.

Table 4. Percentage difference in mean between fatigue life models

Fatigue life, cycles		Difference, %
Probabilistic mean	Discrete mean	
4.272×10^6	4.355×10^6	1.92

The connection between probabilistic fatigue life cycles and discrete fatigue life cycles can be attributed to their distinct approaches to the evaluation of the durability of materials or components under cyclic loading conditions. In this specific case, the percentage difference between the two models serves as a valuable tool for confirming the accuracy of the fatigue life cycle results. The results for the probabilistic approach are shown to have a low probability of failure life when compared to the discrete life model solution.

In the analysis of the variable relationships depicted on the scatter plot in Figure 7, the graph's trend line shape indicates the x and y-axis data set's adequacy. The data points closely align with the trend line, demonstrating a strong and linear relationship, which is likely to give accurate future predictions. The trend line confirms that a degree of blade geometric mistuning is inversely proportional to the fatigue life of the mistuned blades.

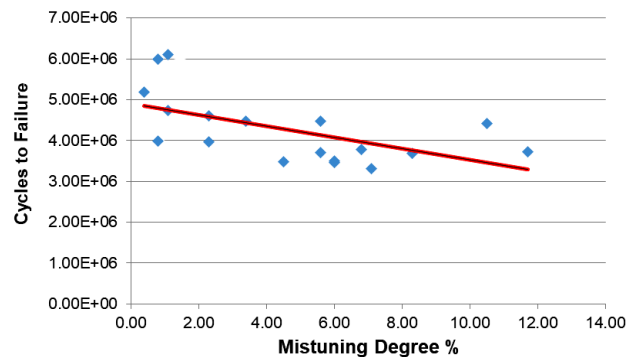

Figure 7. Mistuning degree vs. cycles to failure

Figure 8 illustrates the PDF of the probabilistic life model. PDF of the normal distribution is calculated with Equation (4) in statistical distributions.

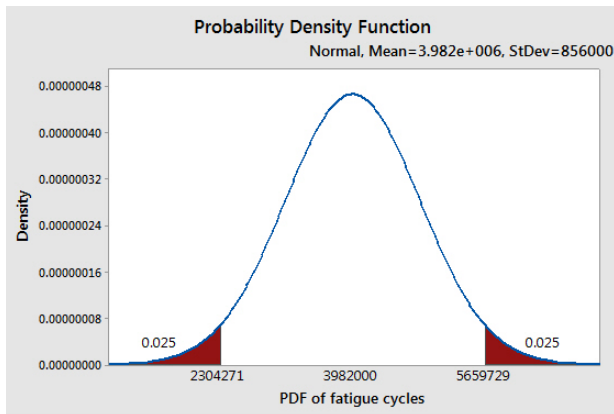

Figure 8. PDF of the probabilistic life model

Utilising the Monte Carlo simulation method successfully produced a PDF model shown in Figure 8. The presented data in Figure 8 indicates the fatigue lives of the bladed disc distributed from 2.304×10^6 to 5.659×10^6 cycles with a mean of 3.982×10^6 cycles. This life correlates well with the probabilistic and discrete fatigue life cycles mean of 4.272×10^6 and 4.355×10^6 , respectively (Table 4). For increased mixed variables case 6 in Table 2, 8 blades maintained the 4.245×10^6 cycles before failure. The minimum life cycles of 4.043×10^6 presented in Figure 4 fall within that range.

The probabilistic fatigue life's mean results correspond with the discrete fatigue life cycles yielded by the *fe-safe* software with approximately a 1.92 % difference, as shown in Table 4. The discrete mean is calculated from Figure 7. The mean of the PDF life cycles in Table 5, taken from Figure 8, and the probabilistic mean calculated from Table 2, exhibit a percentage difference of 7.03 %. Analysing the percentage difference, it becomes evident that the means have a lower percentage. Thus it can be concluded that the developed numerical methodology can be used for real-life mistuned steam turbine blades subjected to variations in blade geometry.

Table 5. Percentage difference in mean for PDF and probabilistic fatigue life

Fatigue life, cycles		Difference, %
PDF mean	Probabilistic mean	
3.982×10^6	4.272×10^6	7.03

5. Conclusion

The HCF life of the blade during operation has been computed in *fe-safe* software. The Brown-Miller algorithm in conjunction with the Dang Van multiaxial method employed in *fe-safe* software for HCF life prediction was used. The simulated

bladed disc results show that fatigue initiate at the blade hot spot, located at the blade root.

The mistuning percentage is set randomly in an assumption to follow the normal distribution. Finally, the Monte Carlo method was used for the development of the distribution plot and probabilistic density to obtain the probabilistic fatigue life of the research study. When the degree of mistuning increases, fatigue life cycles decrease. The discrete results correspond with the probabilistic fatigue life model results, showing a variance of 1.92 % for ASTM 304 stainless steel.

Acknowledgement

This work was financed by the Tshwane University of Technology.

References

- [1] N.F. Rieger, The diagnosis and correction of steam turbine blade problems, in N.F. Rieger (Ed.), *Rotordynamics 2*, Springer, Vienna, 1988, pp. 453-483, DOI: [10.1007/978-3-7091-2846-6_18](https://doi.org/10.1007/978-3-7091-2846-6_18)
- [2] D. Zhang, J. Hong, Y. Ma, L. Chen, A probability method for prediction on high cycle fatigue of blades caused by aerodynamic loads, *Advances in Engineering Software*, Vol. 42, No. 12, 2011, pp. 1059-1073, DOI: [10.1016/j.advengsoft.2011.07.010](https://doi.org/10.1016/j.advengsoft.2011.07.010)
- [3] C. Booyen, P.S. Heyns, M.P. Hindley, R. Scheepers, Fatigue life assessment of a low pressure steam turbine blade during transient resonant conditions using a probabilistic approach, *International Journal of Fatigue*, Vol. 73, 2015, pp. 17-26, DOI: [10.1016/j.ijfatigue.2014.11.007](https://doi.org/10.1016/j.ijfatigue.2014.11.007)
- [4] J.S. Rao, N.S. Vyas, Determination of blade stresses under constant speed and transient conditions with nonlinear damping, *Journal of Engineering for Gas Turbines and Power*, Vol. 118, No. 2, 1996, pp. 424-433, DOI: [10.1115/1.2816607](https://doi.org/10.1115/1.2816607)
- [5] F. Schönleitner, L. Traussnig, A. Marn, F. Heitmeir, Detection of blade mistuning in a low pressure turbine rotor resulting from manufacturing tolerances and differences in blade mounting, *Journal of Mechanics Engineering and Automation*, Vol. 5, No. 5, 2015, pp. 297-308, DOI: [10.17265/2159-5275/2015.05.005](https://doi.org/10.17265/2159-5275/2015.05.005)
- [6] Y.J. Yan, P.L. Cui, H.N. Hao, Vibration mechanism of a mistuned bladed-disk, *Journal of Sound and Vibration*, Vol. 317, No. 1-2, 2008, pp. 294-307, DOI: [10.1016/j.jsv.2008.03.006](https://doi.org/10.1016/j.jsv.2008.03.006)
- [7] H. Liao, J. Wang, J. Yao, Q. Li, Mistuning forced response characteristics analysis of mistuned bladed disks, *Journal of Engineering for Gas*

- Turbines and Power, Vol. 132, No. 12, 2010, Paper 122501, DOI: [10.1115/1.4001054](https://doi.org/10.1115/1.4001054)
- [8] N.K. Mukhopadhyay, S. Ghosh Chowdhury, G. Das, I. Chatteraj, S.K. Das., D.K. Bhattacharya, An investigation of the failure of low pressure steam turbine blades, *Engineering Failure Analysis*, Vol. 5, No. 3, 1998, pp. 181-193, DOI: [10.1016/S1350-6307\(98\)00016-8](https://doi.org/10.1016/S1350-6307(98)00016-8)
- [9] S.M. Ross, Distributions of sampling statistics, in S.M. Ross, *Introduction to Probability and Statistics for Engineers and Scientists*, Academic Press, London, 2021, pp. 221-244, DOI: [10.1016/B978-0-12-824346-6.00015-6](https://doi.org/10.1016/B978-0-12-824346-6.00015-6)
- [10] T.K. Mofoka, *Fatigue Life Prediction of Mistuned Turbomachinery Blades*, MSc thesis, Tshwane University of Technology, Pretoria, 2018.
- [11] Methods and formulas for probability distributions, available at: <https://support.minitab.com/en-us/minitab/21/help-and-how-to/probability-distributions-random-data-and-resampling-analyses/how-to/probability-distributions/methods-and-formulas/methods-and-formulas>, accessed: 12.09.2023.
- [12] J.-S. Kim, U.-C. Jeong, J.-H. Seo, Y.-D. Kim, O.-D. Lee, J.-E. Oh, Noise reduction of dry vacuum pump using the boundary element method to model impeller blade passage frequency, *Applied Acoustics*, Vol. 93, 2015, pp. 51-64, DOI: [10.1016/j.apacoust.2015.01.016](https://doi.org/10.1016/j.apacoust.2015.01.016)
- [13] Y.Q. Laibi, S.K. Shather, Effect of SiC-Cu electrode on material removal rate, tool wear and surface roughness in EDM process, *Engineering and Technology Journal*, Vol. 38, No. 9A, 2020, pp. 1406-1413, DOI: [10.30684/etj.v38i9A.552](https://doi.org/10.30684/etj.v38i9A.552)
- [14] J.L. Ocaña, M. Morales, J.A. Porro, C. Correa, J.J. García-Ballesteros, O. García, Numerical modelling and experimental implementation of laser shock micro-forming of thin metal sheets, *International Journal of Microstructure and Materials Properties*, Vol. 10, No. 1, 2015, pp. 31-46, DOI: [10.1504/IJMMP.2015.068314](https://doi.org/10.1504/IJMMP.2015.068314)
- [15] M.H. Mashiachidi, D.A. Desai, Prediction of fatigue life of mistuned steam turbine blades subjected to variations in blade geometry, in *Proceedings of the 11th International Conference on Advanced Technologies (ICAT '23)*, 17-19.08.2023, Istanbul, Turkey, pp. 89-94, DOI: [10.58190/icat.2023.22](https://doi.org/10.58190/icat.2023.22)
- [16] R.F. Orsagh, M.J. Roemer, *Examination of successful modal analysis techniques used for bladed-disk assemblies*, Report, Impact Technologies, New York, 2002.
- [17] A.E. Ismail, A.K. Ariffin, S. Abdullah, M.J. Ghazali, Probabilistic assessments of the plate using Monte Carlo simulation, *IOP Conference Series: Materials Science and Engineering*, Vol. 17, 2011, Paper 012029, DOI: [10.1088/1757-899X/17/1/012029](https://doi.org/10.1088/1757-899X/17/1/012029)
- [18] X.-P. Niu, R.-Z. Wang, D. Liao, S.-P. Zhu, X.-C. Zhang, B. Keshtegar, Probabilistic modeling of uncertainties in fatigue reliability analysis of turbine bladed disks, *International Journal of Fatigue*, Vol. 142, 2021, Paper 105912, DOI: [10.1016/j.ijfatigue.2020.105912](https://doi.org/10.1016/j.ijfatigue.2020.105912)
- [19] Y. Tan, C. Zang, E.P. Petrov, Mistuning sensitivity and optimization for bladed disks using high-fidelity models, *Mechanical Systems and Signal Processing*, Vol. 124, 2019, pp. 502-523, DOI: [10.1016/j.ymsp.2019.02.002](https://doi.org/10.1016/j.ymsp.2019.02.002)