

## Article

---

"Crossing the Gap: The 1st Canadian Division Engineers and Bridge Construction 1939-1945"

Bill Rawling

*Scientia Canadensis: Canadian Journal of the History of Science, Technology and Medicine / Scientia*

*Canadensis : revue canadienne d'histoire des sciences, des techniques et de la médecine* , vol. 9, n° 2,  
(29) 1985, p. 114-132.

Pour citer cet article, utiliser l'information suivante :

URI: <http://id.erudit.org/iderudit/800213ar>

DOI: 10.7202/800213ar

Note : les règles d'écriture des références bibliographiques peuvent varier selon les différents domaines du savoir.

---

Ce document est protégé par la loi sur le droit d'auteur. L'utilisation des services d'Érudit (y compris la reproduction) est assujettie à sa politique d'utilisation que vous pouvez consulter à l'URI <https://apropos.erudit.org/fr/usagers/politique-dutilisation/>

---

Érudit est un consortium interuniversitaire sans but lucratif composé de l'Université de Montréal, l'Université Laval et l'Université du Québec à Montréal. Il a pour mission la promotion et la valorisation de la recherche. Érudit offre des services d'édition numérique de documents scientifiques depuis 1998.

Pour communiquer avec les responsables d'Érudit : [info@erudit.org](mailto:info@erudit.org)

CROSSING THE GAP:  
THE 1ST CANADIAN DIVISION ENGINEERS  
AND BRIDGE CONSTRUCTION 1939-1945

Bill Rawling\*

(Received 25 March 1985. Revised/accepted 12 November 1985.)

In the course of the Second World War soldiers saw the increased use of technology for air, sea and land forces and their supporting arms. By the end of the war radar, the jet and the main battle tank had made their way from drawing boards into the arsenals of the warring powers. On land, technological developments were used to ensure the rapid movement of troops and equipment. The German *Blitzkrieg* is perhaps the best example of this violent mobile warfare as it set the norm for Axis and Allied armies alike.

The main obstacle to rapid movement over land was not necessarily the enemy's attempts to stop one's advance but the limits imposed by geography. Rivers especially could be formidable obstacles for a tank column, if fords were few and far between. It was thus often necessary to call upon the engineers to prepare crossings, either by filling in the obstacle or by bridging across it. The Canadian Army was no exception. Each infantry division included in its ranks three field companies and one park company of engineers whose task was, among other things, to ensure the rapid movement of the division in an advance, including the construction of bridges over rivers, streams and creeks that were otherwise impassable.

By studying the engineers of the 1st Canadian Infantry Division, one can trace the relationship between the sappers, as the field engineers were called, and the technology -- in this case the bridges -- they had to work with. Though the division had some forty-two months in which to train, certain problems such as how to build under shell-fire could not be solved until the formation began combat operations in Sicily. The engineers' war, then, can be divided into two periods. The first lasted from mobilization in September 1939 to the embarkation for Sicily in late June 1943. In this time the sappers learned the fundamentals of bridge construction and practiced the erection of pre-fabricated and timber bridges. The second period ran from July 1943 to May 1945 and saw the engineers applying their knowledge in Sicily, Italy and the Netherlands often being forced to solve problems that had not been encountered during training in England.

\*Department of History, University of Toronto.

The men under study here had for the most part brought technical skills with them from civilian life. Officers were recruited from the universities, engineering firms and also from among the ranks. Any non-commissioned officer or man who showed promise in the eyes of superior officers might be sent to an officer training camp. The men themselves were recruited from among the skilled trades. In the early days of the war especially, the engineer companies found among their troops blacksmiths, electricians, fitters, surveyors, plumbers, carpenters, draughtsmen, artificers, bricklayers, concretors, masons and miners. These officers and men had the task of applying their technical knowledge and resources to the furtherance of the division commander's plans. To prepare for their role, the sappers underwent military training, such as bridging, to augment their civilian knowledge.<sup>1</sup>

The publication of *Engineer Training: Part I* set the tone for bridge training in England where the 1st Canadian Infantry Division arrived in December 1939. The book was prepared under the direction of the War Office by a staff of Royal Engineers, some of whom were veterans of the First World War. It appeared in early 1940 and laid out in very precise detail how much time recruits, non-commission officers and officers were expected to spend on various aspects of their training. The pamphlet testifies to the engineering complexity, leaving aside tactical considerations, that went into the construction of each bridge. First, the sappers had to prepare approaches to the site and construct abutments. They then had to build piers, over which the actual bridge could be laid. Throughout the operation the engineers had to apply complex skills like pile driving, watermanship and pontooning. *Engineer Training: Part I* allocated six weeks to bridge training, in which time it was hoped the engineers would acquire skills that could be practiced in England's countryside. The sappers would then be able to erect a variety of structures while in proximity to Axis forces.<sup>2</sup>

There were several types of bridging fulfilling the same basic criteria. They had to be quick to build from parts that could be transported on easily-converted three-ton lorries. Each bridge after construction had to be strong enough to handle a certain minimum load. Footbridges could be very light while tank bridges had to be capable of handling thirty-ton loads. Finally, the bridge parts and the completed bridge had to be rugged. Bridges could be separated into two different categories--pontoon and fixed span. If the gap was a river or stream and the banks were not too high, the engineers could build a pontoon bridge which consisted in laying the roadway on floating piers from bank to bank. Pontoons were much quicker to erect than fixed-span bridges which required standing piers.<sup>3</sup> There were several types of pre-fabricated bridges available, and detailed procedures differed from bridge to bridge. Usually, the parts were different though the general order of work was the same. Floating bridges were built by first constructing rafts and then connecting them all together. The structure was then covered with decking to serve as a roadway. Details like railings and kerbs were then added to the bridge.<sup>4</sup>

Before it was possible to build a bridge, officers and sometimes senior NCOs had to gather certain information about the bridge site. Also, they had to ensure that the best area possible was chosen for construction. These men were thus required to check a section of river to find the optimum site for a crossing. Armed with measuring tapes, graduated rods, twine and levels the officers checked the height of banks, current speed, the nature of approaches on both sides of the river as well as sites for unloading and assembling bridge parts. To gather some of this information, reconnaissance parties had to cross into enemy territory, making the task one of the most dangerous of engineer tasks. When all the information had been gathered, the officer prepared a detailed report which the commander used to plan his approach. It was from this report, for example, that the decision was made whether to use a pontoon or a fixed-span bridge.<sup>5</sup> By the spring of 1940, the Canadian engineers had begun training in pontoon bridge construction. They were, however, plagued by equipment deficiencies. At Pangbourne, officers complained that there were not enough raft units to build a bridge all the way across the river. The situation was worsened by the fact that there were no motors for the boats or pontoons. The sappers had to row the pontoons into place, making bridge construction an inordinately long process.<sup>6</sup>

In spite of these difficulties, the engineers learned much. First, there was the problem of unloading the equipment which was carried in lorries specially adapted to carry bridge parts. Since it was highly unlikely that a work site would be large enough to accommodate all the equipment necessary for the construction of a floating bridge, it was crucial for vehicles to arrive in order and be unloaded without delay. The operation could be held up for endless minutes under the watchful eyes of the enemy's artillery spotters if parts were not at hand when they were needed. For example, most pontoons were hooked together with pins. If these had been loaded on the wrong lorry, work could not proceed until they were found. Such embarrassing episodes did occur in these first few months of training, exacerbated by the lack of equipment, as lorries were not available to practice loading and unloading. Company commanders relied on the Royal Engineers to lend them the necessary vehicles.<sup>7</sup>

Once the companies had learned to build the bridge in daytime, they began to practice night construction. This introduced new complexities into an already complicated operation. No lights were used, as these would give away one's position to artillery spotters in actual operations. Discipline was crucial and only the bridge master was allowed to speak, unless a man's safety was in danger. Unloading lorries at night was not only riskier, but could easily lead to loss of critical equipment. Such problems could seriously delay the completion of a task, and the first few attempts at night construction often lasted from dusk to dawn where a day build would have taken a few hours.<sup>8</sup>

Training at Wallingford was similar to that at Pangbourne but with fixed-span bridges. Two types of pre-fabricated

bridging were available here in the spring of 1940. The first was the Large Box Girder Bridge (LBG) which as its name implies was formed of box-shaped girders supporting a decked roadway. Its maximum load was forty tons. The Small Box Girder Bridge (SBG) was quicker to build but could only handle half the load. The first problem at hand, as usual, was to ensure all the necessary materials were available. As it turned out, there was not enough LBG equipment to bridge the gap. After a week or so of begging and cajoling by the Canadians, the Royal Engineers supplied the missing parts and training could begin in earnest. By the end of the ten-day bridge camp, a company of engineers could put up an LBG one hundred thirty feet long in about six and one-half hours.<sup>9</sup>

In the spring and summer of 1940 then, the officers, NCOs and men of the engineer companies of the 1st Canadian Infantry Division were familiarized with the bridge equipment they were expected to use once operations began against Axis forces. To keep their knowledge up to date, the engineers practiced their skills on bridge schemes. These consisted in spending several days building bridge after bridge under simulated combat conditions. Success was measured by the amount of time it took for the sappers to complete their task. 4 Field Company went on such an exercise from 1 to 8 August 1940 and their experience was typical. In the course of the scheme, the company's three field sections built six bridges, three of which were made of Folding Boat Equipment (FBE) and three of SBG equipment. A section of sixty men managed to erect two hundred feet of floating bridge in three and one-half hours and sixty-four feet of SBG in the same amount of time. Other sections did as well. Obviously, floating bridges were the quickest to build. As the summer of 1940 wore to a close, the Canadian engineers increased their proficiency in construction. Near the end of August, 1 Field Company's sections each built one hundred feet of FBG in less than two hours; one section managed to put the structure up in fifty-five minutes and tear it down in forty-nine.<sup>10</sup>

So far, the engineer companies had used almost exclusively pre-fabricated bridge equipment in all their construction schemes. Such material would not always be available on the battlefield, however, so the engineers also had to learn to improvise crossings with whatever they could gather from their immediate surroundings. Improvised bridges were usually made of timber, although steel cubes and girders were sometimes available from Royal Engineer stores to add strength to the piers or roadway. They could not be floating structures because the construction of wooden or steel pontoons would simply have taken too much time and required the skilled labour of carpenters or molders. Because timber had to be cut and notched and each piece put into place before the next could be used, these bridges took a long time to complete. Engineers constructed such improvised structures only as a last resort.<sup>11</sup>

Through the fall and winter of 1940-41, the engineers were kept busy at other tasks and training. Their knowledge of bridge construction was kept fresh with the use of scale models and the odd competition. The models, supplied by the bridge

manufacturers, were impressive, accurate in every detail including such small items as pins and clamps. Thus all ranks could review their respective positions and tasks in a bridge build while waiting for time and equipment to become available for training. The models were only useful for reviewing the procedure for construction. In January 1941 a kind of bridging olympics was held to spruce up the men's manual skills which could not be done with models.<sup>12</sup>

In February 1941 a new type of bridge was introduced to the sappers of the 1st Canadian Infantry Division. Called the Inglis after the man who developed it, the structure was composed of steel tubing, girders and cable and could be built either as a pontoon or fixed-span bridge. The War Office adopted it because the SBG, LBG or FBE did not share this versatility. Two officers had been sent to Cambridge in the summer to learn how to build the bridge, but serious training at the company level did not begin until several months later. It was quickly found that the bridge was not only versatile but also that it required little manpower to erect. Under the command of an NCO only, sixteen men actually worked on the structure, about a one third of the section. This would allow the remainder of the section to work on approaches and thus ensure the quick completion of the entire project.<sup>13</sup>

After the introduction of the Inglis bridge, the engineers began to experience problems with training. There were simply too many types of bridges to remember, and the situation was worsened by the fact that recruits arrived constantly throughout this period. Though the Inglis was obviously superior to other types of bridges, there was not enough of them produced to replace other types. Also, since priority went to manufacturing infantry, artillery and armoured weapons as well as ships and aircraft, the War Office could not justify scrapping older bridge types because some of them had been superceded. Thus, the sappers had to know how to construct FBE, SBG, LBG, Kapok-Float Foot Bridges, Inglis, Pontoon and Improvised bridges. In April, one company had to halt the practice of timing builds and begin reteaching the erection drills for various bridges. Construction was slowed to a crawl to ensure everyone understood how the work was organized. The same company found that training on the FBE Mark III was hampered by the lack of training pamphlets to use as reference material. These problems could only be solved with constant training. Until the end of the war, men were retrained on bridge work whenever time and equipment permitted.<sup>14</sup>

In April 1941, for the first time, the engineers began to train with the infantry in earnest. This was important, for the sappers were expected to support the division as a whole. Various aspects of a bridge construction operation were put to practice with the infantry regiments of the formation. The first part of such an enterprise was mainly in the hands of the infantry who had to capture a bridgehead on the far bank before the sappers could begin construction. This was carried out using boats and/or assault bridging to effect a crossing. The Kapok-Float Foot Bridge, which could be erected in a few minutes, was often used on these exercises. Exercise HARE,

which lasted from 9 to 11 April 1941, was the first application within the 1st Division of combined infantry-engineer skills. Each of the three field companies<sup>15</sup> detached a section to one of the Infantry Brigades to aid in assault water crossings and build the bridges with SBG equipment to allow follow-up forces to cross in mass.<sup>16</sup> These exercises were important in that they exposed the engineers to some of the conditions they would encounter on the battlefield.<sup>17</sup>

Training, field exercises and equipment maintenance soon became routine. Instructors continued to use models when the time or equipment did not allow hands-on training, which was carried out when feasible, often on only a few hours' notice. 2 Field Park Company ensured the equipment was maintained while 1 Field, 3 Field and 4 Field Companies tried to keep up on their bridging skills.

In late October 1941 Major Tregillus, an engineer in Division Headquarters, was sent to Ripon in central England to witness a Bailey bridge demonstration. He was the first Royal Canadian Engineer officer from the 1st Canadian Infantry Division to see the new bridge, which would eventually become the most important piece of water-crossing equipment in the division's stores. Designed in 1940 by Donald C. (later Sir Donald) Bailey, a civilian engineer of the Royal Engineers Experimental Bridging Establishment at Christchurch, it soon proved itself to be one of the most adaptable types of bridging in the world.<sup>18</sup> It was not until June 1942 that other officers and some NCOs managed to examine the new structure, which in sapper lore became known as the 'technical wonder of the Western World.' The first training build with the new equipment took place on 29 June 1942.<sup>19</sup>

The Bailey bridge was both more complex and more versatile than the types that preceded it (see Figures A and B). It could be built as a raft, pontoon bridge or fixed-span structure. Ten-foot-long panels which could be lifted by six-man crews supported the load. The roadway, which ran between the panels, was itself supported by transoms. These could be lifted by eight-man crews. Stringers were placed on the transoms and decking, or chesses, were then positioned into place on the stringers. The basic type of Bailey called for one row of panels each side of the roadway. These could be increased, however, to strengthen the bridge. In Italy, it was common to build Baileys with three rows of panels each side of the roadway. It was technically possible to build up, thus adding stories to rows to a total of three or nine rows of panels altogether. It was therefore possible to construct a light bridge quickly if loads were not heavy or a heavy bridge more slowly if the engineers expected large loads, all with the same bridging equipment. Load-carrying capacity varied from thirty to eighty tons.<sup>20</sup>

Training with the Bailey was interspersed with work on the other bridge types. On 2 July 1942 the companies of the division began a long, elaborate bridge camp in which they were to spend two weeks on each of the SBG, the Bailey and the FBE, a sign that these bridges were considered most important or the

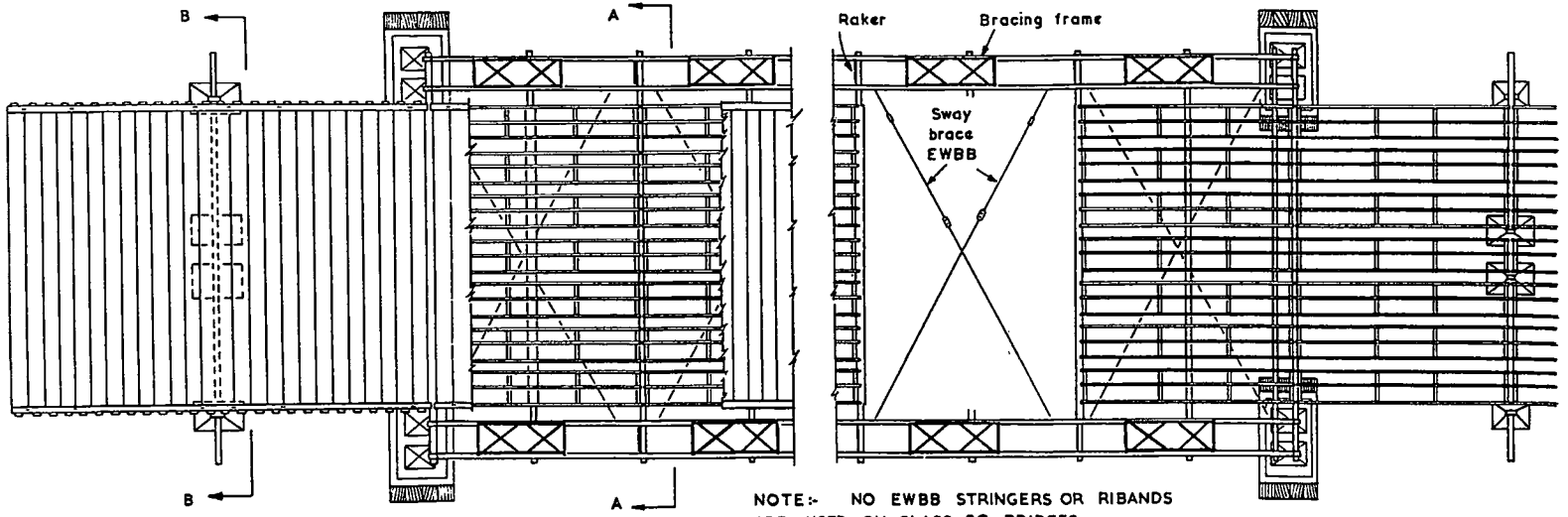
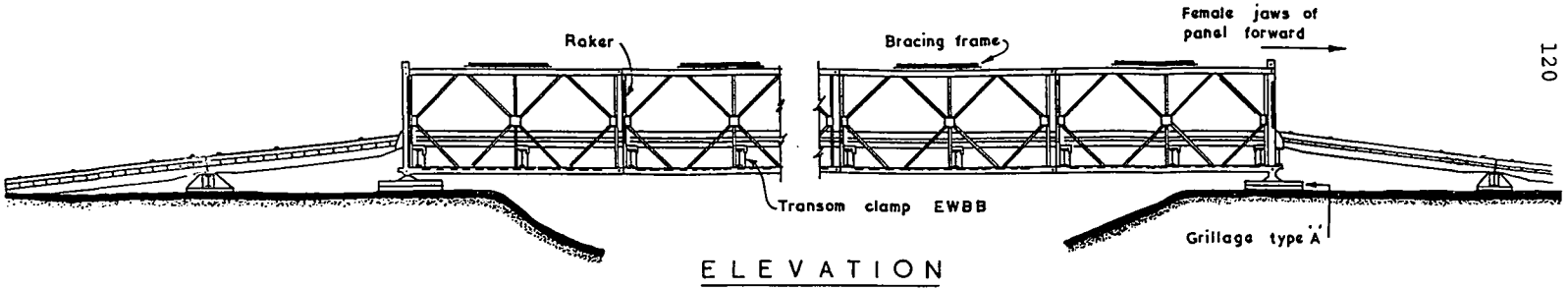

NOTE:- NO EWBB STRINGERS OR RIBANDS ARE USED ON CLASS 30 BRIDGES

FIGURE 1: EXTRA WIDE BAILEY BRIDGE



FIGURE 2: ELEMENTS OF THE BATTERY BRIDGE

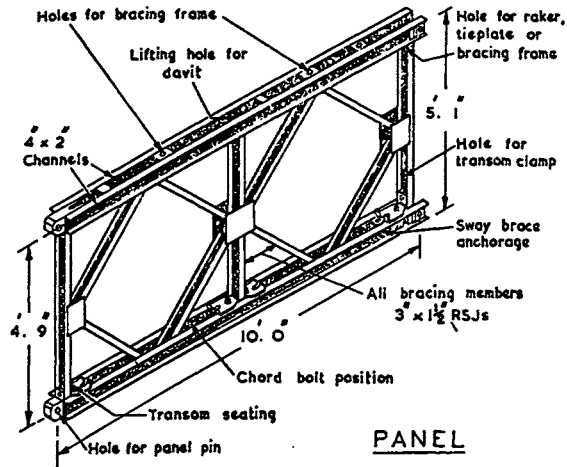

**PANEL**

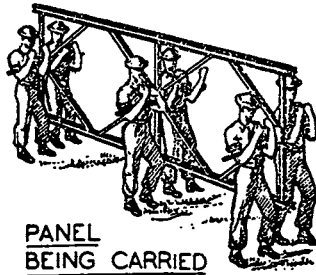
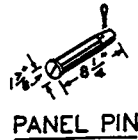
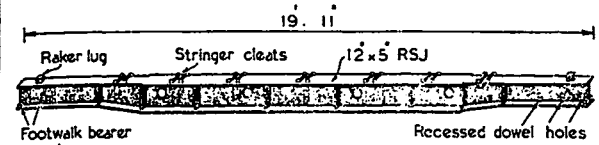
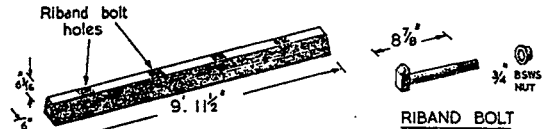
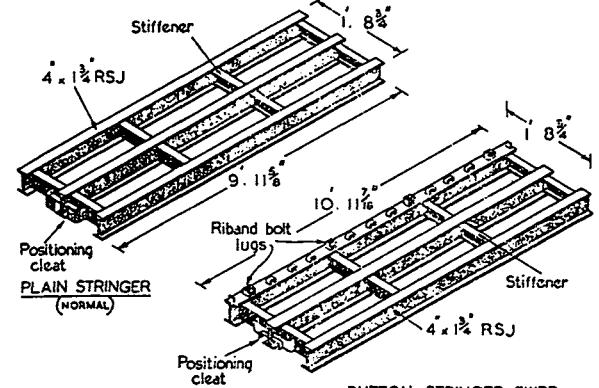

Fig 2—Panel and panel pins



**TRANSOM**



**RIBAND (NORMAL)**  
NOTE. THE RIBAND EWBB IS 10' 11 1/8" LONG  
BUT OTHERWISE IDENTICAL

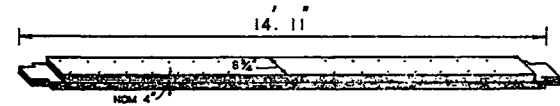

Fig 3.—Transom and deck members

most difficult to build. As with all new equipment, there were technical problems with the Bailey at first. 2 Field Park quickly discovered that the jacks used in raising or lowering the bridge filled with grit under field conditions and ceased to function properly. This could seriously hamper work on the structure, as it had to be jacked up and off construction rollers and then jacked down on the bearing plates before it could be used. The problem was easily solved, however, by simply replacing the jacks with something more rugged available in engineer stores.<sup>21</sup>

The engineers of the division quickly mastered the intricacies of the Bailey. On 24 August 1942, 4 Field Company constructed no fewer than four of the structures. Class 30 Bridges<sup>22</sup> from 100 to 120 feet in length went up in two or fewer hours.<sup>23</sup> Bridge training reached a plateau on Exercise SPINACH from 11 to 22 September 1942. Between them, the field companies put up sixteen bridges and operated five rafts. The worst disaster of the exercise occurred when 3 Field Company required six hours to build a fifty-foot Bailey after they dropped it into the river. One of the quickest builds was attributed to 1 Field Company who managed to construct a 240-foot class-9 FBE in two hours and fifteen minutes and then maintained the structure in good working order as vehicles heavier than nine tons crossed. One of the most complicated builds of the exercise was also 1 Field's responsibility. The structure had to cross a fifty-foot gap, an island thirty to fifty feet wide and another fifty-foot gap. A continuous span would have been too long and tricky to build and the island was too small to use as a work site, so the bridge commander came up with a complicated plan to complete the project. First, the company built a Bailey from the home bank to the island. Then an FBE, which was easy and quick to build but incapable of handling heavy traffic, was constructed from the far side of the island to the 'enemy' bank. This allowed the engineers to take enough Bailey parts across to begin a build from the far bank to the island and connect it to the first Bailey with a ramp. The engineers became more and more innovative in their approach to bridge construction.<sup>24</sup>

In early 1943 the Allies decided to storm the beaches of Sicily in July and thus open up the long-awaited offensive against Hitler's Europe. Two questions immediately came to mind. How would it be possible to get the troops ashore? What do they do then? The engineers figured in the solutions to both these dilemmas. The doctrine for beach assaults had not been fully developed before 1943, when *Combined Operations - Royal Engineers* appeared in March. The book detailed the duties of the engineers as the infantry moved across the beaches. At Z, the time the assaulting troops hit the shore, the sappers' lead sections would accompany them in order to remove obstacles through demolitions. Fifteen minutes later more engineers would arrive to assist tracked vehicles and trucks through any minefields by removing mines so as to form lanes. Simultaneously they would search out a series of exits from the beach so the advance could continue. Thirty minutes after the landing, bulldozers would arrive to assist the engineers in preparing exits as well as setting up landing areas on the beach

for stores and men. Finally, one hour after the initial landing, the leading field companies were supposed to move inland to support the infantry and armoured units in their advance.<sup>25</sup> Bridging experience was important both for the sappers who moved inland to maintain the advance and for those who remained on the beaches to ensure supplies moved forward. While the former built bridges over any serious obstacles the brigades encountered, the latter constructed fish quays and jetties to receive water-borne supplies.<sup>26</sup>

From April to July 1943 the engineers carried out little bridge training because their time was taken up with other concerns. They practiced techniques of combined operations with the infantry battalions they would be supporting in the assault, and they organized the tons of equipment they would be taking ashore to fulfill their various roles in support of the division's advance across Sicily. The division, as part of an Anglo-American invasion force, landed on 10 July 1943 against light opposition and began to push inland; the time for training was over.

On 21 July 1943 the engineers of the 1st Canadian Infantry Division built their first bridge of the Sicilian campaign. The mission foreshadowed the problems both the engineers and the troops they supported would have to overcome. The operation began when Lieutenant D.D. Love, under cover of darkness, managed to get close enough to the gap to estimate it to be forty feet wide. After daybreak, a reconnaissance party approached the site to get accurate measurements of the gap and determine the approaches' hardness. They were immediately driven away by enemy fire from the town of Leonforte, and it was evident that the infantry would have to secure a bridgehead before work could begin (See map). At 2100 on 22 July, the Loyal Edmonton Regiment crossed the river in assault boats and captured the town of Leonforte. Bridging operations began one half-hour later. The forty-foot bridge was in place at 0200 on 23 July and the first vehicle crossed five hours later. The entire operation had taken over two days.<sup>27</sup> In training, the bridge would have been up within six hours of the engineers' arrival on site. Bridges were important to both sides. The assaulting troops needed them to ensure that the tanks, trucks and supplies they required to fight their way through the enemy forces, while the Germans wanted to ensure that the bridges were not built so as to cut their enemies off from their much-needed supply routes. Technology itself became both ally and target.

The 1st Canadian Infantry Division ceased operations in August and the engineers were left to train and rest. During the lull, the sappers practiced, among other things, bridge construction to ensure they were at the peak of efficiency for upcoming operations on the Italian mainland. 1 Field Company set a new record for quick construction by putting up eighty feet of Bailey in one hour and eight minutes. Other companies, though not breaking any records, managed to satisfy their commanders. There were, however, some problems on the tactical side of things. Though timings were good, the engineers were neglecting some of the crucial steps necessary to build bridges

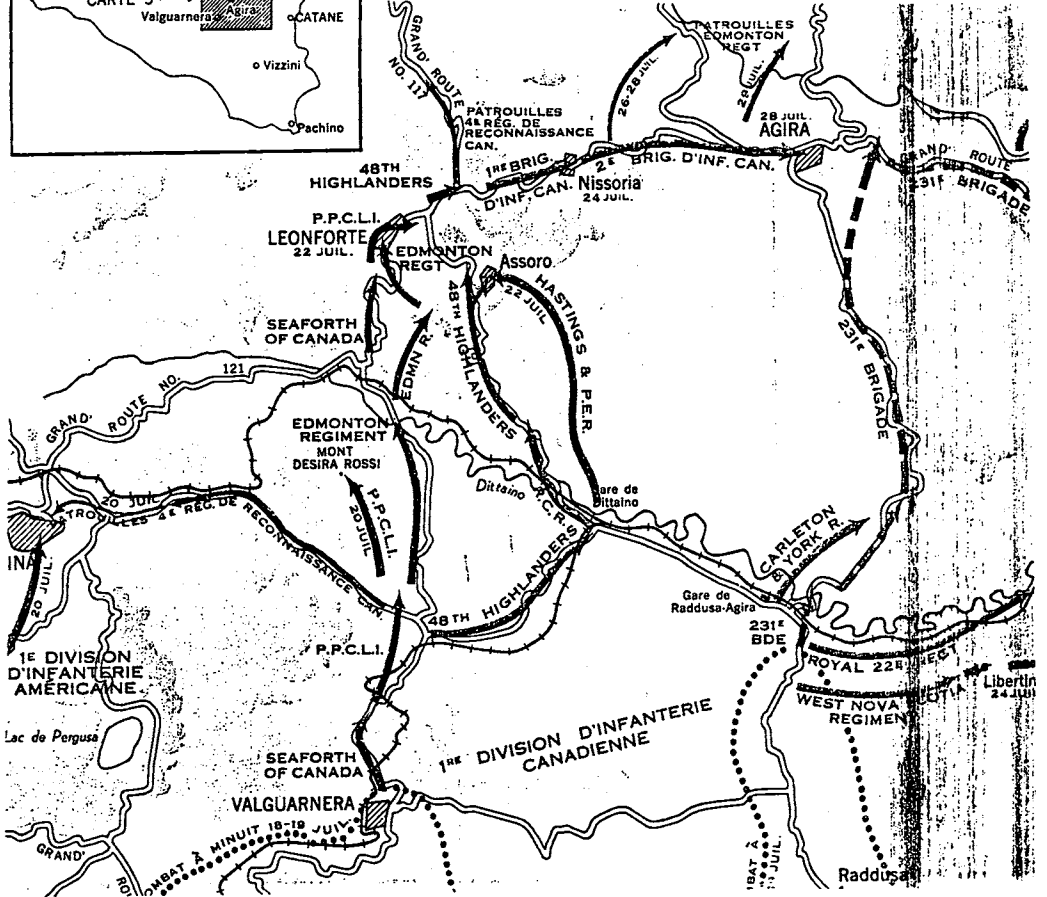
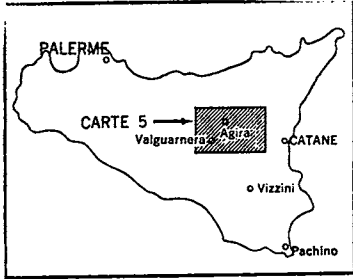

ENGAGEMENT AT LEONFORTE, SICILY

safely. While on exercise or in competition, they often failed to sweep the work site for mines or post sentries to warn against possible enemy attack. An exploding mine or a burst of machine gun fire could inflict heavy casualties and bring a bridge build to a halt. Also, the stores layout was sometimes confusing, which was no problem when one could stop to sort things out but could be devastating on a night build when artillery was flying and everyone was nervous.<sup>28</sup> Assault bridges like the Bailey had been designed to go up in crisis situations. Though the sappers could master the technical complexity of the bridge, the fact that the Germans opposed them with all the means of mass destruction made the engineers somewhat more than technicians: they became soldiers as well. Tactical considerations could thus be as important as technical skill when building bridges.

On 3 September 1943 the 1st Canadian Infantry Division, again as part of an Anglo-American invasion force, invaded the mainland at Reggio di Calabria. Immediately, one of the field companies began to build a bridge just a few miles off the beach. This was no easy task. The far bank was actually a causeway too narrow to hold a Bailey bridge. Transoms, the horizontal girders that support the bridge's roadway, were placed on the causeway, in effect widening it. This field modification allowed the engineers to complete their task.<sup>29</sup>

A few weeks later the engineers were faced with a problem which taxed their knowledge even more. It was common in the advance for certain materials to fall behind. So it was on 22 September when 1 Field Company found itself with a fifty-foot gap and only thirty feet worth of bridge. The solution eventually adopted was to make two major changes to the construction drills. First, the nose was eliminated. This was formed of the same parts as the rest of the bridge and measured about half the total bridge length. Its purpose was twofold. First, the nose was supposed to land on rollers on the far bank so the entire structure could be pushed into place. Second, it ensured that the bridge's centre of gravity never went past the rollers on the near bank. In essence it turned the entire bridge into a seesaw. The nose could not be removed until the bridge was in place and so left the engineers with spare parts. The engineers came up with the novel idea of using the parts for the nose in the actual structure of the bridge. The solution was to build the whole bridge on the near bank and then use a huge counterweight (probably a bulldozer) on the rear of the bridge to launch it to the far side. The second part of the solution was to eliminate the Bailey ramp leading from the roadway to the edge of the bridge, which was normally built above ground. These parts could then also be used in the structure, though this required the engineers to dig out the bank in order to make the bridge roadway level with the road. After much time spent in pushing, shoving and praying, the job was completed. A total rethinking of established procedures had been necessary.<sup>30</sup> The incident demonstrated two things. First, the engineers had reached a level of expertise through almost constant practice that allowed them to improvise from first principles when they encountered a problem that had not been experienced in training. Second, the Bailey bridge itself

was versatile enough to allow such improvisations.

Some problems could only be solved with sweat and hard work. Something the sappers had not had to deal with while training in England was the Mediterranean weather. In Italy rain quickly turned streams into torrents and roads into quagmires. Since a bridge is only as good as its approaches, the weather at times became a more serious problem than enemy shells. At least shell holes could be filled, but a field of mud and clay had to be drained and paved with gravel. It was not unusual for a bridge build to take three or four hours while the approaches took a full seven or eight hours more.<sup>31</sup>

There were of course problems in bridging that required both serious thought and hard work. If rivers were close together, as was often the case in Italy, the sappers would have to erect several bridges in double quick time for the division could not afford to wait as the engineers stopped to roganize for each bridge site. As the war progressed, the Germans became quite proficient at destroying bridges. The solution adopted was the 'bridge gallop.' In November a field company had three bridges to build in quick succession. The plan was to slap them in one after the other with platoons leap-frogging to their sites. 2 Platoon was the first to leave with its bridging equipment, completing its task with 3 Platoon looking on. 3 Platoon then passed over the newly-completed bridge to build another with 1 Platoon following closely to erect still another. Before 1 Platoon had finished the structure, however, the company was ordered to build two more bridges which it also successfully completed. All five bridges were operating within twenty-four hours of the order to build having been given.<sup>32</sup>

With experience the sappers not only became quick at solving new and complicated bridging problems, but also their speed in construction increased. A new record was set when 3 Platoon of 1 Field Company built a class-30, ninety-foot Bailey in four and one-half hours. On 29 November, the same unit reported that it had crossed eighteen gaps in five days.<sup>33</sup>

By the end of 1943 the Bailey and the FBE were the only two bridges in regular use by Canadian engineers, the former for strength and the latter for speed. Other types were considered obsolete or stockpiled for the upcoming Normandy landings. As will be seen below, supplies were limited. During a lull in January 1944, these two types of bridge were the only ones new recruits practiced with during training. One officer said of the Bailey, 'Men are quite interested (in training) for to most the equipment is new. We all begin to wonder if there is anything the Bailey cannot do.'<sup>34</sup> Thus, with fewer types of bridge to worry about, it was easier to teach the replacements that came in whenever the division rested. Much had changed since England, and new recruits had to be taught the innovations that the Italian weather and topography had forced on the sappers of 1 Division's field companies.<sup>35</sup>

The bridges that had been built since the landings had to be maintained. This entailed the erection of guardrails that had not been put into place during construction. It also required

painting and marking bridges so drivers would be careful in crossing them. This caution was to no avail as trucks continued to slam into the bridges and force the engineers to repair them time and time again. The structures required constant attention and became an important part of the engineers' work programmes when the 1st Canadian Infantry Division was in reserve. There were, however, some opportunities to learn more about the structure of the Bailey bridge during maintenance. Such an opportunity arose when, for the first time, a Bailey was hit by shellfire on 26 January 1944. It was found that it could easily be repaired by replacing some of the damaged parts. The Canadian engineers, who had always preferred working with the Bailey, were impressed even more by its show of ruggedness.<sup>36</sup>

Whenever the division went into reserve to rest and train, the engineers began to remove bridges in the rear so they could be used at the front. This process began in earnest in June 1944.<sup>37</sup> The purpose of the work was to recover bridges that were no longer in use. As the Allied armies moved up the boot of Italy, they captured ports through which their supplies could move to the front. Each time a new port was put into operation, the lines of communication to its predecessor became redundant. Given the scarcity of bridge parts in the Mediterranean theatre because of the build-up for D-Day in the summer of 1944, it was considered important to recover the bridges the engineers had built in the heat of battle so they could be used again. The bridging cycle was thus complete, from construction to maintenance to dismantling.

The engineers were also called upon to solve other, more complex problems. The infantry and especially the armoured units asked the engineers to tackle novel problems; meanwhile, the officers and NCOs of the field companies had built up a wealth of experience that could be directed toward the development of new techniques for river crossings. On 1 July 1944, the 4th Princess Louise Dragoon Guards, who were involved in long-range reconnaissance, asked the engineers to design a new type of bridge. The structure was completely new in concept, for the reconnaissance unit wanted it to be portable. The armoured units felt that their missions would be easier to carry out if they had a twenty-foot bridge that could be carried in jeep trailers. Such a device would allow them to cross small rivers and streams quickly without having to perform a time-consuming reconnaissance to find a ford, thereby affording them much greater mobility in the Italian terrain. The bridge only had to be strong enough for jeeps, the main vehicle in reconnaissance work. The engineers came up with not one but several designs constructed of timber which would meet the needs of the Princess Louise.<sup>38</sup> The engineers then prefabricated bridges for other corps.

In March 1945 the 1st Canadian Infantry Division was transferred to the Northwest European theatre of operations to join the 1st Canadian Army in its march through the Netherlands. As in Sicily and Italy, bridges were needed to maintain lines of communication. They were also the subject of the only major training carried out in the final months of the war. The

Germans were destroying dikes to delay the Allied advance, so soon after their arrival in the new theatre, the engineer companies went to a bridge camp to practice their skills. Some of the results were phenomenal. While training on the Waal, 1 Field Company managed to build 480 feet of floating bridge in little more than an hour. Though floating bridges were easier and quicker to build than fixed-span bridges, the company's speed was unprecedented.<sup>39</sup> 4 Field Company took four and one-half hours to complete the same length of bridge.<sup>40</sup> Training ended on 4 April. Though not all the units repeated 1 Field Company's incredible build, their level of ability was very high. Five years of training and experience in England and the Italian campaign had honed their skills. Bridge equipment was complex and required time to master. By 1945 technical and tactical questions related to bridges were familiar to the sappers. Hands-on training and experience were necessary for them to reach their late-war level of expertise.

The floating bridge training was put to the test during Operation CANNONSHOT, in which the engineers demonstrated their experience and proficiency. The operation was supposed to push troops across the River Ijssel and cut off elements of the German 25th Army. Planning began on 5 April, with reconnaissance patrols beginning on the 7th. Crossing sites were chosen the following day and the operation began on the 11th. The division's objective was the town of Apeldoorn and all its engineer companies were involved in the crossing. On the face of it, the battle looked like a well-conducted exercise.<sup>41</sup>

The reconnaissance patrols carried out by the engineers reminded them of bridge camp where of course there is no enemy to deal with. The division was opposed by a paratroop training battalion reinforced with naval troops. Neither seemed interested in doing harm to the reconnaissance parties. One of the company diarists was pleasantly surprised. 'A new type of battle this is - when recon parties can prowl about in the open on a river bank and not be shot at from the far bank.'<sup>42</sup> This first phase of the operation was similar to most training exercises, where the worst danger was falling into the river. Tactical considerations lost much of their importance and the engineers could place more emphasis on technical matters.

The actual assault was somewhat more hazardous. In 1 Company's area of responsibility, the infantry crossed in amphibious Buffaloes at 1630 and had captured a bridgehead within ninety minutes. Meanwhile, the engineers worked on the construction of a raft to bring up the tank support. It was not completed until 2100 because enemy artillery was firing air bursts, which spread glowing hot shrapnel over the entire site. The company also built a mine boom in case the Germans should float mines down the river to sink the heavily laden ferries. The operation was a success and the company crossed to the other side on the afternoon of the 12th.<sup>43</sup>

The mission given to 3 Field Company was somewhat different. Four sections were to go with the assaulting infantry to prepare exits for the Buffaloes ferrying troops across. The



remaining engineers from the company would then cross, sweep a path on the far side and prepare an exit for the bridge 4 Field Company was supposed to build.<sup>44</sup> There was little opposition to the assault and all went according to plan. The diarist described the operation as a 'textbook crossing.' As with 1 Field's operation, 3 Field's was carried out with little difficulty and no fatalities.<sup>45</sup>

Finally, there was 4 Field Company's mission which was the construction of a 360-foot floating bridge which infantry, armoured elements and 3 Field Company were supposed to cross. The unit worked under heavy fire but sustained only two minor casualties. Beginning at 1800 they completed construction of the bridge at 2230. After the division had moved on, 3 Platoon remained behind to maintain the crossing. The operation was completed without serious delays.<sup>46</sup>

The engineers of the 1st Canadian Infantry Division had learned long before how to work under artillery fire while building bridges to span the raging gorges and ragged gullies of Italy. They could judge artillery and determine whether it was truly effective by listening to the fall of shot. If the incoming shells were not a serious threat, the sappers carried on with their work even though artillery fire whistled and exploded seemingly only yards away. Only battle-hardened troops could carry on in this manner.

After the operation the division moved on. Its lines of communication were limited, however, to what the engineers had put across the Ijssel. This meant that all supplies had to cross either on the floating bridge which could carry only nine tons, or the raft which was capable of hauling forty tons but took time to cross the river. These crossings were under much pressure as a result and so it was decided to build a Bailey bridge to allow the faster movement of supplies. The engineers continued to improve the division's lines of communications long after the infantry, armour and artillery had moved forward, giving the front depth.<sup>47</sup>

The next assault water crossing operation came as something of a surprise to the engineers but served to demonstrate their ability to prepare for work on very short notice. Captain Bailey, the Acting Officer Commanding of 1 Field Company, was roused from his sleep at 0445 on 17 April with the news that the Royal Canadian Regiment was crossing the Apeldoorn canal. On short notice, the company built a first bridge across the canal by 0740 and a Bailey bridge in the town by 1100. The unit then crossed and followed the infantry, removing obstacles to the advance. With little or no preparation, the engineers of the company had thus managed to carry out a complete bridging task. The engineers were beginning to show an impressive adroitness.<sup>48</sup>

For the engineers of the 1st Canadian Infantry Division, Apeldoorn was the last bridging operation of the war. On 7 May 1945 the Germans surrendered unconditionally, and the sappers were put to work dismantling some bridges while strengthening others for peacetime traffic. In the course of

some five years and more, the officers, NCOs and men of the field companies had learned much about the complicated task of constructing bridges and near the end of the war had become experts. In studying their trials, tribulations and accomplishments, one comes to realize how complex bridging operations could be. In the course of learning what to do with the new technology, some bridges were dropped in the river, others floated away and still others remained uncompleted. Eventually drills were developed, new techniques improvised and procedures seriously altered -- and experience proved the master.

## NOTES

1. War Office, *Engineer Training Part I: Individual and Collective Training*, 1 January 1941. Public Archives of Canada (PAC), Records of the Department of National Defence. War Diaries, RG 24, Volume 14, 713, Appendix 9, 4 Field Company, May 1941; Appendix IV, March 1941.
2. National Defence Headquarters, Directorate of History (D Hist), Training Manuals, FN 7, *Engineer Training Part I*, Appendix D, 56.
3. PAC, Records of the Department of National Defence, War Diaries, RG 24, vol. 14, 689, of 1st Canadian Division Headquarters - Engineers, 22 February 1940; vol. 14, 701, 1 Field Company, 4 March 1940; vol. 14, 709, 3 Field Company, 3 March 1940.
4. *Ibid.*, vol. 14, 712, 4 Field Company, 9 March 1940.
5. *Ibid.*, vol. 14, 701, 1 Field Company, 16 March 1940 to 16 March 1940.
6. *Ibid.*, vol. 14, 712, 4 Field Company, Appendix II, 9 March 1940; vol. 14, 701, 1 Field Company, 11 March 1940.
7. *Ibid.*, vol. 14, 701, 1 Field Company, 9 March 1940.
8. *Ibid.*, vol. 14, 701, 1 Field Company, 13 March 1940.
9. *Ibid.*, 16 March 1940; vol. 14, 709, 3 Field Company, 13 March 1940; vol. 14, 701, 1 Field Company, 23 March 1940. According to *Engineer Training Part I*, bridging training was broken down as follows:
 

Approaches and Abutments, Trestle and Cribs ...	1 wk
Watermanship and Pontooning .....	2 wks
Assault Boats, Reconnaissance Boats,	
Assault Bridging, FBE, Pile Driving .....	1 1/3 wks
SBG and Inglis .....	1 1/3 wks
10. *Ibid.*, vol. 14, 712, 4 Field Company, 1 August 1940; vol. 14, 701, 1 Field Company, 21 August 1940 to 23 August 1940.
11. *Ibid.*, vol. 14, 709, 3 Field Company, 3 November 1940; vol. 14, 701, 1 Field Company, 11 November to 17 November 1940.

12. *Ibid.*, vol. 14, 701, 1 Field Company, 25 November 1940; vol. 14, 713, 4 Field Company, 6 January 1941, 22 January 1941.
13. *Ibid.*, vol. 14, 701, 1 Field Company, 19 August 1940; vol. 14, 709, 3 Field Company, Appendix J, 24 February 1941; vol. 14, 689, 1st Division Headquarters - Engineers, 28 February 1941.
14. *Ibid.*, vol. 14, 702, 1 Field Company, 15 April 1941, 16 April 1941.
15. The term 'field company' refers to an engineer unit composed of an active strength of about two hundred men. It usually worked closely with an infantry brigade.
16. PAC, Records of the Department of National Defence, RG 24, vol. 14, 709, 3 Field Company, 31 March to 5 April 1941; vol. 14, 689, 1st Division Headquarters - Engineers, 9 April 1941; vol. 14, 777, 2 Field Park Company, 10 April 1941.
17. *Ibid.*, vol. 14, 689, 1st Division Headquarters - Engineers, 27-28 May 1941.
18. A.J. Kerry and W.A. McDill, *The History of the Corps of Royal Canadian Engineers, Volume II 1926-1940* (Ottawa, 1966), 92.
19. PAC, Records of the Department of National Defence, RG 24, 30 October 1941; vol. 14, 702, 1 Field Company, 17 June, 29 June, 2 November 1941.
20. *Ibid.*, vol. 14, 690, 1st Division Headquarters - Engineers, 2 July, 5 July, 20 July 1942; vol. 14, 710, 3 Field Company, 10-31 July 1942; vol. 14, 778, 2 Field Park Company, 21 July 1942.
21. *Ibid.*, vol. 14, 702, 1 Field Company, 4-5 August 1942.
22. A class-30 bridge would have been capable of handling a thirty-ton load without danger. Thus a class-80 could take eighty tons, a class-12 twelve tons and so on.
23. PAC, Records of the Department of National Defence, RG 24, vol. 14, 714, 4 Field Company, 34-28 August 1942.
24. *Ibid.*, vol. 14, 710, 3 Field Company, 13-22 September 1942; vol. 14, 702, 1 Field Company, 13-20 September 1942; vol. 14, 714, 4 Field Company, 13-22 September 1942; vol. 14, 690, 1st Division Headquarters - Engineers, 11 September 1942.
25. War Office, *Combined Operations - Royal Engineers 1943*, March 1943, 32.
26. PAC, Records of the Department of National Defence, RG 24, vol. 14, 715, 4 Field Company, 7 March 1943.
27. *Ibid.*, vol. 14, 711, 3 Field Company, 21 July 1943.

28. *Ibid.*, vol. 14, 711, 3 Field Company, 17 July 1943; vol. 14, 703, 1 Field Company, 23 August 1943; vol. 14, 691, 1st Division Headquarters - Engineers, Appendix 12, 27 August 1943.
29. *Ibid.*, vol. 14, 703, 1 Field Company, 3 September 1943.
30. *Ibid.*, vol. 14, 703, 1 Field Company, 22 September 1943.
31. *Ibid.*, vol. 14, 715, 4 Field Company, 30 October 1943.
32. *Ibid.*, vol. 14, 703, 1 Field Company, 9-12 November 1943.
33. *Ibid.*, 27-30 November 1943.
34. *Ibid.*, vol. 14, 711, 3 Field Company, 5 March 1944.
35. *Ibid.*, vol. 14, 715, 4 Field Company, Appendix 4, 22-30 January 1944.
36. *Ibid.*, vol. 14, 704, 1 Field Company, 22, 26 January 1944; vol. 14, 711, 3 Field Company, 26 February 1944; vol. 14, 691, 1st Division Headquarters - Engineers, 25 January 1944.
37. *Ibid.*, vol. 14, 716, 4 Field Company, June 1944; vol. 14, 691, 1st Division Headquarters - Engineers, 6 June 1944; vol. 14, 711, 3 Field Company, 10 June 1944.
38. *Ibid.*, vol. 14, 706, 1 Field Company, 27 March 1945.
39. *Ibid.*, vol. 14, 717, 4 Field Company, 29 March 1945.
40. *Ibid.*, vol. 14, 692, 1st Division Headquarters - Engineers, 5 April 1945; vol. 14, 706, 1 Field Company, 6 April 1945.
41. *Ibid.*, vol. 14, 706, 1 Field Company, 10 April 1945.
42. *Ibid.*, 11 April 1945.
43. *Ibid.*, vol. 14, 711, 3 Field Company, 10 April 1945.
44. *Ibid.*, 11 April 1945.
45. *Ibid.*, vol. 14, 717, 4 Field Company, 10-12 April 1945.
46. *Ibid.*, vol. 14, 692, 1st Division Headquarters - Engineers, 13 April 1945.
47. *Ibid.*, vol. 14, 706, 1 Field Company, 17 April 1945.
48. *Ibid.*, vol. 14, 706, 1st Division Headquarters - Engineers, 7 May 1945.