

This is a repository copy of *Bulla Regia II : Excavations in the Christian cemetery*.

White Rose Research Online URL for this paper:

<https://eprints.whiterose.ac.uk/207522/>

Version: Published Version

Article:

Fenwick, Corisande, Chaouali, Moheddine, Alexander, Michelle orcid.org/0000-0001-8000-3639 et al. (9 more authors) (2023) *Bulla Regia II : Excavations in the Christian cemetery*. *Libyan Studies*. pp. 123-134. ISSN 2052-6148

<https://doi.org/10.1017/lis.2023.20>

Reuse

This article is distributed under the terms of the Creative Commons Attribution (CC BY) licence. This licence allows you to distribute, remix, tweak, and build upon the work, even commercially, as long as you credit the authors for the original work. More information and the full terms of the licence here:

<https://creativecommons.org/licenses/>

Takedown

If you consider content in White Rose Research Online to be in breach of UK law, please notify us by emailing eprints@whiterose.ac.uk including the URL of the record and the reason for the withdrawal request.

Article

Bulla Regia II: Excavations in the Christian cemetery

Corisande Fenwick¹, Moheddine Chaouali², Michelle Alexander³, Dirk Booms¹, Samantha L. Cox⁴, Alice Di Muro³, Constanze Höpken⁵, Guy Hopkinson¹, Heike Möller⁶, Efthymia Nikita⁷, Anita Radini⁸ and Nicholas Ray⁹

¹University of London; ²Institut National de Patrimoine (INP), Tunis; ³University of York; ⁴University of Pennsylvania; ⁵University of Cologne; ⁶Deutsches Archäologisches Institut, Berlin; ⁷The Cyprus Institute; ⁸University College Dublin and ⁹University of Leicester

Abstract

This paper reports the preliminary results from three seasons of excavations in the Christian cemetery by the Tunisian-British Bulla Regia Archaeological Project. In 2017–2019, excavations in, and around, the Late Antique church in the western cemetery uncovered a complex funerary landscape with a variety of different tomb types, including mosaic caisson tombs, simple masonry tombs, amphora tombs, and earthen graves and multiple funerary *mensae*. The mosaics, inscriptions and finds (ceramics, glass, coins) studied in 2022 support a fourth to seventh century date for the main period of use of the cemetery.

بولا ريجيا الجزء الثاني:
أعمال التنقيب في المقبرة المسيحية

تعرض هذه الورقة للنتائج الأولية لثلاثة مواسم من التنقيب في المقبرة المسيحية من قبل مشروع بولا ريجيا التونسي-البريطاني الأثري. في 2017–2019، كشفت أعما التنقيب في الكنيسة العتيقة المتأخرة وما حولها عند المقبرة الغربية عن مشهد جنازتي معقد يضم مجموعة متنوعة من أنواع المقابر المختلفة، بما في ذلك صناديق الفسيفساء، والمقابر الحجرية البسيطة، ومقابر الأمفورا، وقبور ترابية (مدافن في الأرض) بالإضافة إلى عدد من الطاولات الجنائزية. إن الفسيفساء والنقوش والاكتشافات المختلفة من السيراميك والزجاج والعملات المعدنية و التي تمت دراستها في عام 2022 تدعم أن الفترة الرئيسية لاستخدام المقبرة هي من القرن الرابع إلى القرن السابع.

Keywords: late antique church, tomb, mosaic, amphora, inscriptions

Introduction

The Tunisian–British Bulla Regia Project is a collaborative project between the Institut National du Patrimoine (INP) and University College London (UCL), which investigates the Late Antique and early medieval history of the town of Bulla Regia in northern Tunisia. This article presents the preliminary results of excavations at a Late Antique church and cemetery discovered to the west of the protected site boundaries of Bulla Regia during a rescue excavation in 2010. The aim of these excavations is to explore the development of Christianity at the site, and to understand the diet, health, lifestyle, origins and mobility of its inhabitants. The church and its surrounding cemetery (Figure 1) have been the subject of four, short field seasons of intensive investigation, initiated with a geophysical survey in 2016, and followed by architectural analysis in 2017 (Chaouali *et al.* 2018). Excavations between 2017 and 2019 have focused on two trenches: a funerary chapel (Room 3) inside the church, and an area of the cemetery south-east of the church. This article first presents the preliminary results of our excavations, and then brief summaries of the ceramic and glass finds, the human remains, isotopic analysis and micro-debris analysis of the dental calculus.

The funerary church and cemetery

A complex Late Antique funerary landscape has been uncovered in, and around, the church to the west of the pagan cemetery

Corresponding author: Corisande Fenwick, email: c.fenwick@ucl.ac.uk

Cite this article: Fenwick C *et al.* (2023). Bulla Regia II: Excavations in the Christian cemetery. *Libyan Studies* 54, 123–134. <https://doi.org/10.1017/lis.2023.20>

excavated by Louis Carton in the 1890s (Carton 1890a; 1890b). To date, 281 tombs have been identified within the excavation limits which can be further divided into the following areas (Figure 2):

The **church** (Area 1000) is a three-naved basilica, which was probably constructed in the late fourth to fifth century. It served as a funerary space in its earliest phases; however, the number and distribution of tombs within the naves is unknown. A test sondage in the southern nave identified at least two layers of superimposed stone cist tombs; the uppermost tombs were marked with mosaics which served as a floor to the church. At some point in the sixth century, the church was remodelled, and a paved surface closed off the basilica to burial (see Chaouali *et al.* 2018 for a full account of the phasing). A series of **funerary annexes** to the north, west and south of the church contain further burials. Rooms 1–4 to the north contain predominantly mosaic tomb markers commemorating men, women and children, as well as two priests. To the south, Rooms 7 and 10 also contain several funerary mosaics, while the apsed Room 8 contains stone cist graves. Room 12, the latest annex added to the church, contained stone cist graves, including one inscribed to the bishop Proculus (see Chaouali 2019). Some, but not all, of the tombs in Room 1 and Room 12 were excavated in 2010. The 2017–2019 excavations focused on Room 3 where we have excavated six tombs to date; a further two tombs were excavated in the sondage in the main church.

A **walled enclosure** (Area 2000: 26.3 × 24.3 m) to the west of the church contains at least 98 tombs. These are typically stepped masonry tombs, mortared or covered in mosaics; below the cover is an unmortared, stone-slab burial cist or a simple undecorated sarcophagus, though they vary in quality of construction.

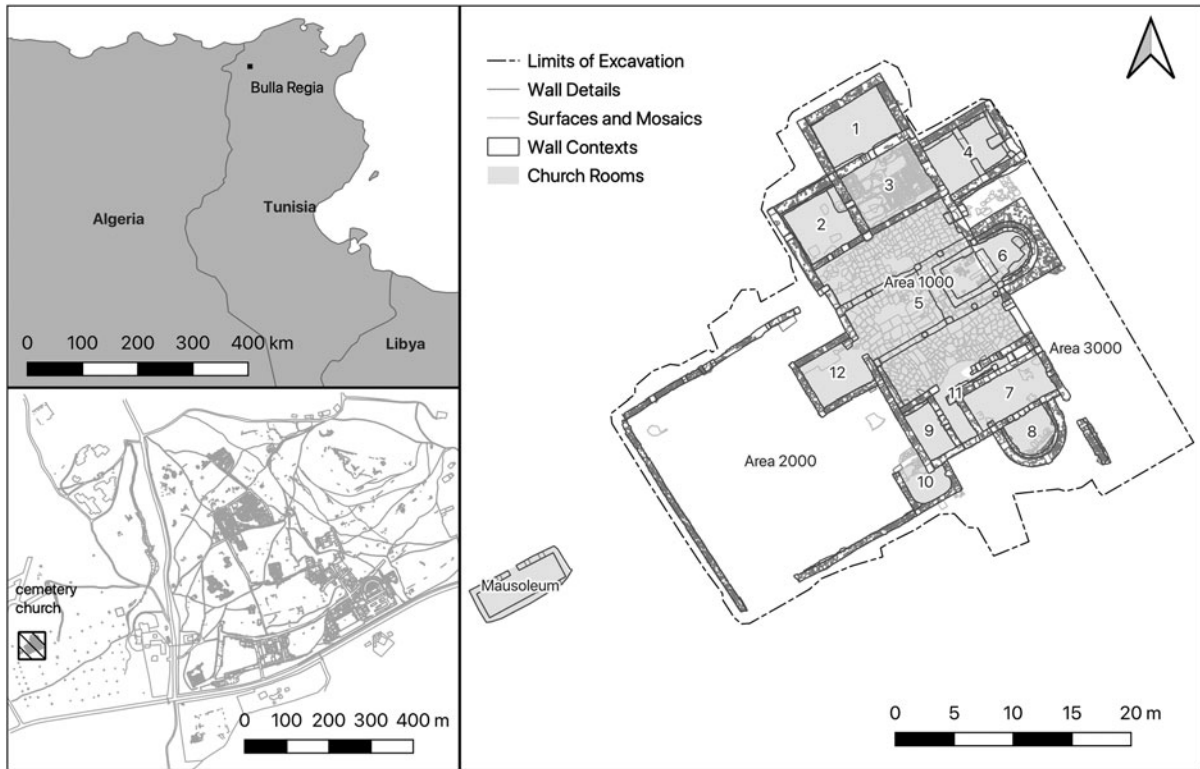

Figure 1. Plan of funerary church at Bulla Regia and its location (INP/UCL, Bulla Regia Project).

Several funerary *mensae* – grave markers above one or more burials with surfaces for hosting funerary banquets – are in the enclosure, and one was cut by the construction of Room 12. During the 2010 rescue excavations, 21 tombs were excavated in

the west of the enclosure. Three, probably late, tombs of infants at risk of destruction were excavated in 2018.

A substantial **outer cemetery** surrounds the church and the walled enclosure. The full extent of the cemetery has yet to be



Figure 2. Plan of church and cemetery showing excavated tombs in 2010 and 2017–19 excavations (INP/UCL, Bulla Regia Project).



Figure 3. Mausoleum showing sarcophagus excavated by INP in 2010 rescue excavations (Moheddine Chaouali).

determined, but we have identified at least 87 tombs outside the church and enclosure within the limits of excavation. A large diversity of tomb types including mausolea, funerary *mensae*, mosaic-clad tombs, mortared tombs, rubble tombs and earthen graves have been noted. Eleven tombs were excavated in the 2010 rescue excavations: eight to the north of the enclosure wall and three to the south-west of the church entrance. During the 2017–2019 campaigns, we opened a trench (Area 3000) immediately to the south-east of the church apse, which contains at least 67 tombs, of which 16 have been excavated to date.

To the west of the walled enclosure, a Late Antique, below-ground **mausoleum** was also excavated in 2010. It contained the large marble sarcophagus of a single individual and three later graves cut into the floor (Figure 3). Jewellery and nine bronze *nummi* of Justin II (r. 565–574) were found in one of the later graves, giving a *terminus post quem* of the second half of the sixth century (see Chaouali *et al.* 2018).

The 2017–2019 excavations

The funerary annex (Room 3) – Area 1000

Room 3 is one of a series of small funerary annexes on the north side of the church. Though several mosaics were lifted in Room 3 in the 2010 rescue excavations, none of the underlying tombs had been investigated, offering the ideal opportunity to excavate the burials of a complete funerary annex (Figure 4). Traces of several mosaics remained *in situ*; these were lifted and conserved in 2018.

The room (6.75 x 5 m) has *opus africanum* walls and four entrances leading into the *quadratum populi* of the church, and other funerary annexes (Rooms 1, 2, and 4). It contains 18

tombs built below ground; each was covered with a mosaic tomb cover. All were similarly constructed with minor variations (Figure 5). Each tomb was dug into the dark grey packing clay present throughout the room; the cut was lined by upright stone slabs or stone blocks creating a space for the body to be interred. The burial was closed by large stone slabs, which were first covered by either a series of thin mortar, levelling layers or thick, hewn limestone blocks, followed by a thick layer of smaller mortared stones, and levelled with a layer of hard mortar or sand, on top of which was the softer mortar preparation for the funerary mosaic.

The surviving tomb mosaics are similar in style and composition: each has an upper field with a wreath and an inscription below it, while some have an additional lower field with decorative elements. The lower fields most often have a simple patterning, such as hexagons, triangles, stars or crosses, but in a few examples they are elaborate and figurative. Borders are often ornate, displaying triangles, semi-circles or guilloches, while most wreaths contain a chi-rho motif and sometimes alpha and omega. The colour palette is limited to red and yellow Chintou marble, white and black stones, and blue and green glass; however, the execution is often of a high quality and the skills of the craftsmen can clearly be recognised. Several mosaics use different hues of white, yellow and red, creating fluent transitions between the colours and playing with shading. M5, for example, uses complex patterning, with alternating light and dark, and yellow and red tesserae between octants of a wreath (Figure 6). Mosaic inscriptions commonly include the phrase *IN PACE* after the deceased's name, and in some cases also their age. A double tomb mosaic (M19, M20) commemorating two women, Restituta Inocens (*sic*) and Onorata (*sic*) Fidelis (Figure 7), is more elaborate than most others in the church complex and warrants further description. While Onorata has a very simple wreath with stylised flowers and a plain inscription on a field of hexagons, Restituta has a brilliant wreath in shaded hues, elaborate multi-coloured flowers and two decorated fields. The upper field depicts variegated leaves, and the lower one portrays a detailed peacock of blue and green glass tesserae standing among flowers (Figure 8). Currently, the relationship between the two women remains unknown, and although the mosaics appear to be linked, the difference in elaboration and quality is striking.

So far, six tombs have been excavated. In the centre of the room was T215. Its cist contained a lead coffin with the remarkably well-preserved skeleton of a robust adult male 1362* (Figure 9). Small pieces of fabric are probably the remnants of the shroud. The funerary mosaic M40 was removed in 2010. Its inscription commemorates *VICTORINVS PRESBITER IN PACE*, 'Victorinus the priest, in peace', which explains the use of an expensive lead sarcophagus, the higher quality construction and the prestigious position within the room. In the north-west corner of the room, T208 contained the incomplete skeleton of an adult, probably female, 1323* buried in the supine position. The tomb was covered by M5, which was cut and destroyed at a later date in order to insert an infant grave in the lower half; it was then backfilled with earth, rubble and many tesserae, probably those of M5. In the south-east of the room, T222 contained only a few remains of unarticulated children's bones. Its mosaic M18 shows a wreath with a chi-rho motif, the dedication *TRIBVNVS IN PACE* and a St Andrew's Cross. To its south, another infant grave, T223, also contained only a few unarticulated bones 1347*. Several tombs show signs of ancient destruction or disturbance. On the eastern side of the room, T220 contained a small concentration of bones, 1339*, which had been pushed to the side when the cist was re-opened to insert a second body 1324*. Between those two phases, T221 to the south had been built over the original south wall of T220. It contained the skeleton of an adolescent 1332* – parts of its skull were found in the



Figure 4. Orthophoto of Room 3 mid-excavation, with all five mosaics visible. Rubble packing layers in T218, 219, and 220 have already been removed (INP/UCL, Bulla Regia Project).

secondary fill of T220. The southern half of T221 had in turn been cut away, including half of its mosaic M4, to place a second body in the tomb, after which the mosaic was restored. Its top shows a wreath with a chi-rho motif; of the reconstructed bottom part, the inscription *ANNIS XVII* could still be read, indicating that the deceased was 17 years old, which is consistent with the maturation of the skeleton. T218 and T219 have been only partially excavated, but they also appear to have been re-opened at a later stage to insert additional individuals.

At a later date, the entrances into Rooms 1 and 4 were blocked, as was the door into the *quadratum populi*. An abandonment layer was preserved in the south-eastern part of the room, which in turn was covered by the collapse of the southern wall of the room. One particularly large block, probably a door lintel, was responsible for the subsidence of M19 and M20.

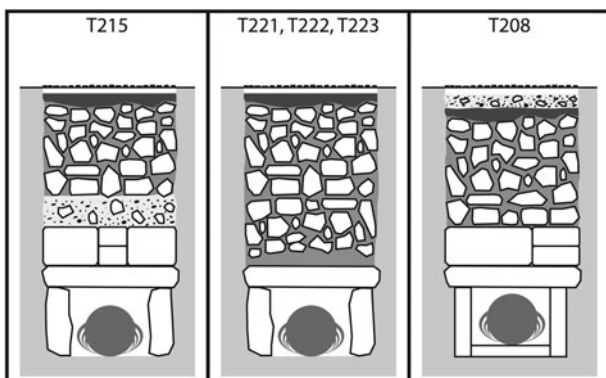

Figure 5. Tomb construction in Room 3 (Samantha Cox).



Figure 6. M5 – detail (Dirk Booms).



Figure 7. Double tomb mosaic (M19 and M20) of Restituta Inocens (*sic*) and Onorata Fidelis (Dirk Booms).

The outer cemetery – Area 3000

The area surrounding the church served as a substantial cemetery with built tombs and earthen graves. In 2017, a trench ('Area 3000') was opened on the southern side to investigate the relationship between the cemetery and the church and to understand funerary practices in late antiquity (Figure 10).

The earliest feature identified is a wall of large, neatly finished ashlar blocks [1335] which pre-dates the construction of the eastern façade of the church (Figure 11), and bonds with ashlar wall [1079] inside the church. This well-built structure might be a mausoleum of the early Roman period.



Figure 8. Detail of peacock (Dirk Booms).



Figure 9. T215, showing the skeleton (1362*) in a lead coffin (Dirk Booms).

The area to its east was given over to several clusters of tombs and funerary *mensae*. None of these features have been excavated and it is as yet unclear whether they predate or postdate the construction of the church. In the south-east of the trench, the earliest features identified are two funerary *mensae* (Figure 12). The southernmost [3164] is a square-shaped platform with a semi-oval raised section on its north side, constructed of stones, and covered in a layer of mortar. Several tombs are built against it. A second sigma-shaped *mensa* [3165] lies 1.5 m north and is a semi-circular mortared platform with a semi-oval recess on the south-eastern side. The interior of the recess is lined with tile and a preserved remnant of the white mosaic that would have originally covered the structure. Seven metres to the north-west is a large, mortared feature [3095], which is probably a funerary *mensa*: it seems to be quadrangular but is not fully exposed. An arrangement of interlocked mortared masonry features lies 2 m to the north-east and is another

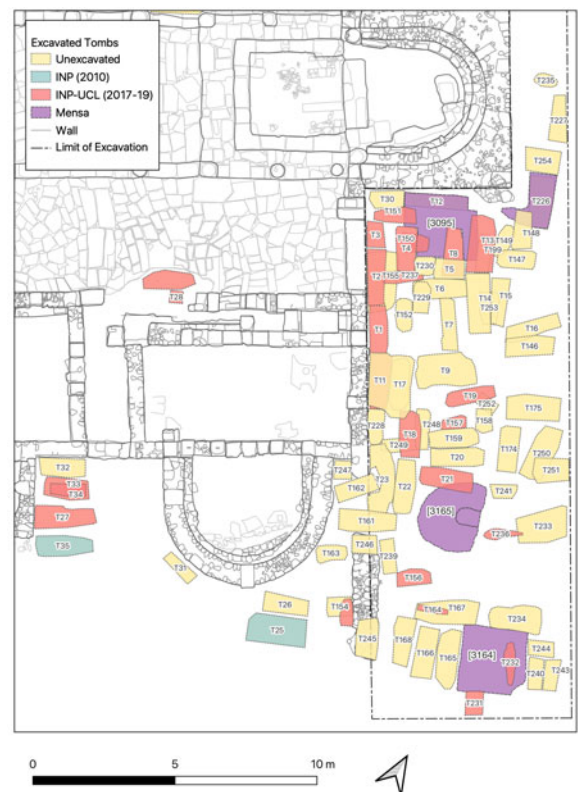

Figure 10. Plan of Area 3000 showing the placement of tombs at the end of 2019 season (INP/UCL, Bulla Regia Project).



Figure 11. Ashlar wall [1335] of a possible mausoleum below the eastern wall [1068] of the church (Corisande Fenwick).

probable funerary *mensa*; some of these features are certainly rectangular tombs, including one which has an illegible inscription (T226).

In a subsequent phase, the eastern apse of the church (Room 6) was built (or remodelled) and its construction cut damaged the mortared feature [3095] from the previous phase. The NE–SW wall [3100] in the south of the trench aligns with the eastern façade of the church and may also date to this phase. The area continued to be used for burial, and new tombs are clustered



Figure 12. Orthophoto of the south of Area 3000 showing two funerary *mensae* (Corisande Fenwick).



Figure 13. T19: tomb cist sealed with amphora (Samantha Cox).

close to the church. The tombs typically have rectangular, rubble-built superstructures; some were clad in mosaics, as indicated by the presence of tesserae or tesserae imprints. We have excavated one tomb from this phase. T19 contained an adult burial 3292*, which was covered by large pieces of broken amphora of the *tradition punique du golfe d'Hammamet*, in a cist of un-mortared stone slabs, which was itself covered by stones and a slab of schist over the feet (Figure 13). Unfortunately, the rim and toe of the vessel are lost so it is difficult to be precise about the date; however, the latest production of this form occurs in the seventh century AD (Bonifay 2004, 92–97). A few infant burials in tile or schist coffins (T157, T158, T235) may be late burials in this phase, or the following phase. Concentrations of coins, ceramics, glass and charred olive pits in the associated cemetery fill layer (3259) indicate intensive use in this phase.

The final phase of cemetery use is characterised by a series of simple, un-mortared cist tombs and earthen graves cut into the fill layers (3066) and (3105). By the church, a series of graves were cut into probable *mensa* [3095], including the SW–NE burial of a child 3113* (T150), the SW–NE anthropoid burial of an adult 3235* (T151) with traces of ochre, the NW–SE burial of an adult male 3027*(T8) and the NW–SE burial of a probable male adult 3123* (T13). These tombs were all covered by large slabs of schist or roof tile and sometimes the burial pit was lined with slabs. Probably contemporary is an earthen grave of an adult female 3092* (T155), whose head had been removed by T2, and is immediately to the south of T150. Four later tombs were built against, or close to, the south-west wall of the church and cut into the latest cemetery fill (3003). These seem to respect a path to the church entrance which was raised in this period by the insertion of two re-used pagan funerary inscriptions which served as a door sill [3067]. These are all NW–SE stone cist tombs with stone slabs or ceramic tiles covering the grave: T2 contained loose bones from an adult; T1 contained an adult, probably male 3022*; T11 contained an adolescent 3184*; and T4 contained a child 3007*. Further south are two graves with multiple interments: T18, a NW–SE stone cist tomb cut into (3091) which contained at least three individuals – an adult female 3067* and two infants 3068*, 3093*, as well as two copper coins. To its south is a similar cist tomb T21 cut into (3091) which contained at least six individuals, including the articulated skeletons of adult female 3090* and adult 3120* and a reduction of two other adults and two children 3064*. Two beads were found within the fill. Perhaps contemporary are five shallow, poorly preserved earthen graves on east–west and north–south orientations in the south of the trench, including an adult female 3278* (T236), an adult, probably female, 3236* (T232), an adult 3220* (T231), a child burial 3160* (T164) and



Figure 14. T232: anthropoid earthen grave cut into *mensa* [3164] in a later phase (Corisande Fenwick).

an adult 3108* (T156). The shape of these graves is difficult to discern; some may have been anthropoid, as in the example of T232 (Figure 14).

The dating of the final two phases is unclear. Fill layers (3259), (3066) and (3105) contain ceramics predominantly from the sixth century; however, sherds from these fills are generally very fragmented, suggesting rapid accumulation processes. The earliest residual sherds in these layers date to between the second century BC and the first century AD, represented by fingernail-sized fragments of so-called Colour Coated Ware (Rhodes?) of South Gaulish Sigillata. The latest ceramic finds are ARS Hayes 90, Calcitic Ware of sixth/possibly seventh century AD. Several pieces, including a bowl with red painting on white ground, utilitarian pottery and storage jars, may date to the seventh to eighth centuries, but this remains hypothetical. A medieval date for some of the burials is further suggested by the presence of a medieval coin (C86) of probable eleventh to twelfth century date in the latest cemetery fill layer (3105).

Ceramics

The majority of the ceramics found in the church and cemetery are typical fifth to sixth/early seventh century AD vessels common in northern Tunisia (for their distribution, see Andreoli and Polla 2019). The assemblage includes common wares, mainly mortars, bowls and jugs of probable local or regional production, as well as tablewares, mainly African Red Slip Ware (ARS) D from Medjerda Valley productions, cooking wares (cf. Late Roman Cooking Ware (Figure 15.3), so-called Calcitic Ware (Figure 15.2) and many lamp fragments, presumably also of

local/regional production. Particularly striking are numerous, well-preserved, large and deep basins found in the church and annexes (e.g., Figure 16.2). It seems that they had a specific liturgical or funerary use, as similar forms are characteristic of Byzantine funerary contexts in Chimtou (Figure 16 and Figure 16.1). An important assemblage of so-called Painted Ware was found in the post-abandonment layers of the church and cemetery enclosure excavated in 2010. These comprise the typical jugs and pitchers with zoomorphic or geometric patterns known throughout the region and beyond (Figure 15.6). A series of open vessels have few published parallels: these comprise small (Figure 15.7) and large bowls (Figure 15.8) with floral and geometric brown and red painting. The latter could be a late production (seventh/eighth? century AD) and thus predecessors of medieval glazed wares with the same or similar decoration, though this remains purely speculative. Vessels of certain medieval date are very rare; however, a few larger jugs and bowls (Figure 15.9–11) made in the eighth? or ninth century are present in the latest accumulation layer in the outer cemetery.

The majority of forms seem to have been produced locally or regionally. The locally/regionally produced common ware is characterised by a reddish-brown to ochre-coloured fracture, sometimes changing to yellowish or greenish. Quartz, microfossils and lime inclusions are usually present. The surface is usually light brown to ochre, rarely also reddish or whitish slipped. The fabric of the Painted Ware is similar to the presumed local common ware productions, but further archaeometric analyses are necessary to understand the production and distribution of this important group of pottery (cf. Fenwick *et al.* 2022). A local or regional production of fine ware is also possible. The presence of a variant of ARS Hayes 91? with rouletting (Figure 15.4) is suggestive: these differ from the known ARS D types (Bonifay 2004, 178), but take the form of the local *mortaria* (as, e.g., Figure 15.5). Other ARS D? productions are similar to the ceramic assemblage at Chimtou (e.g., Figure 15.1; see Von Rummel and Möller 2019) and do not compare with types described by Hayes (1972) or Bonifay (2004). The fracture is usually rough and coarse-grained and pale to orange-red. The quartz inclusions are regularly distributed, aeolian quartz is present, rarely also microfossils. The surface is usually covered with a thin, orange slip. Archaeometric analyses conducted by Claudio Capelli on Chimtou samples suggest Henchir Hamdoune as one possible production area (Von Rummel and Möller 2019, 199) – a similar origin might be postulated for vessels of this production found at Bulla Regia. There is evidence for late pottery production at Bulla Regia: kilns (no longer visible) were noted by Carton in both the north-east baths (Carton 1915, 185) and the baths of Julia Memmia which he putatively dated to the medieval period (Carton 1909, 583; 1922, 333). Our ongoing petrographic analysis should identify local and regional productions of Late Antique forms and wares and, in particular, whether fabrics of pottery made in Bulla Regia and Chimtou can be chemically distinguished.

The glass finds

The majority of glass finds in the church and cemetery date from the fourth to the seventh centuries AD. The assemblage is dominated by vessels, mainly lamps, beakers, goblets and, less commonly, bottles and jugs, characteristic of other church and Late Antique cemetery contexts in Tunisia (see, e.g., Sterrett Krause, 2017; Foy 2003). A few glass beads and bracelet fragments were also found. Glass was also used for details in funerary mosaics (see, for example, Figure 8) and glass tesserae of different colours, including some with gold inlay, have been collected for chemical analysis. A fragment of a glass cake was found in the walled

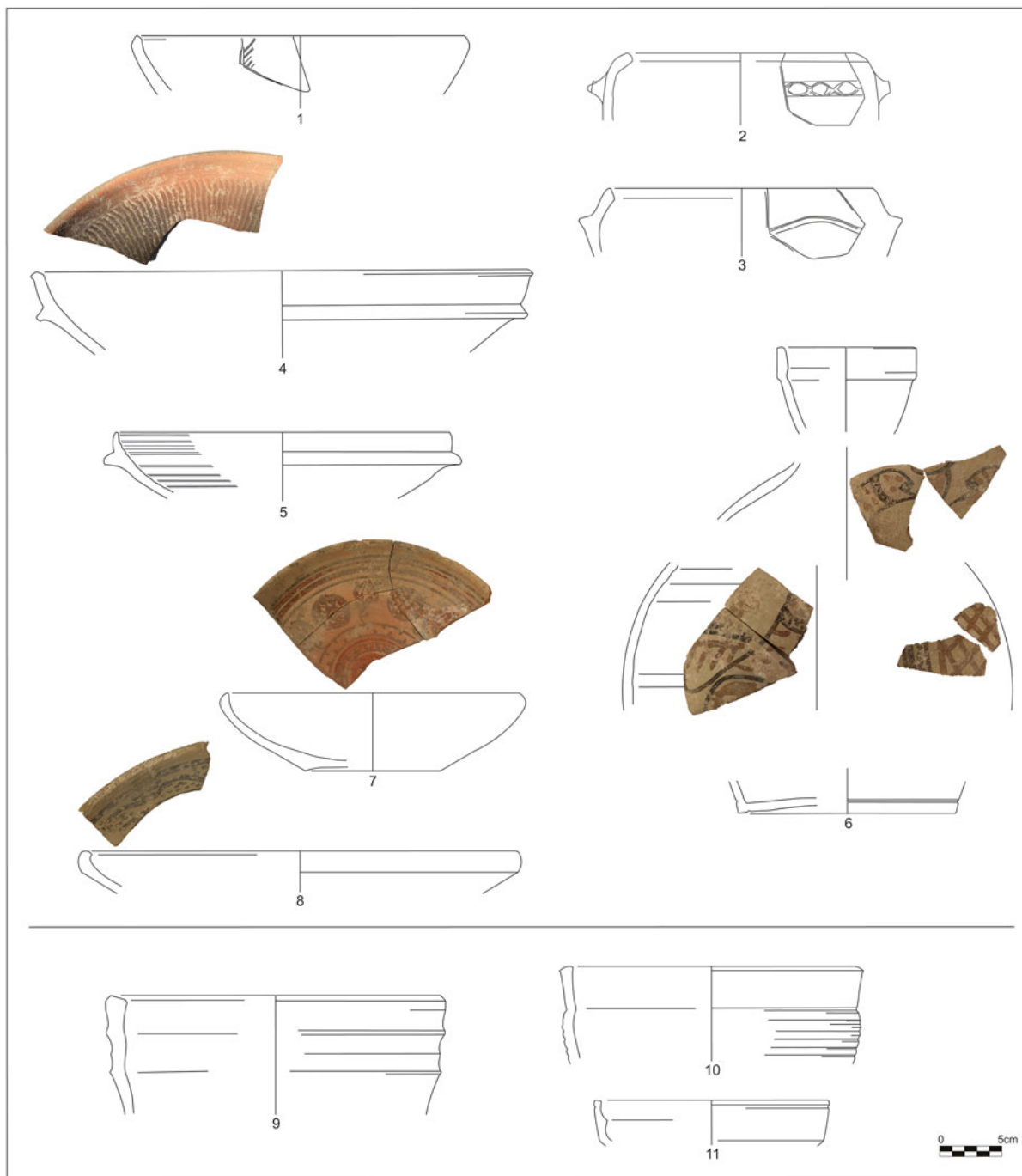

Figure 15. A sample of representative ceramics from the church and cemetery at Bulla Regia (INP/UCL, Bulla Regia Project).

cemetery, which suggests that some of the glass tesserae may have been made (or remelted) on site.

Lamps predominate. About half of all rim sherds have an outfolded rim and most probably belong to beaker-shaped lamps with handles which usually had a slightly convex base (Figure 17.1; see, for example, Foy 2003, 80, Fig. 84; Foy 2011, 211, Fig. 1.1). Many handle fragments can also be assigned to this form. Each lamp would have had three handles, which allowed a chain suspension, so that each one could be hung individually. Many of the cracked-off rims may also have belonged to beakers – in this case probably of conical-shaped lamps (Figure 17.2; cf. Foy 2003, 72, Fig. 37). There are a few stemmed lamps with rounded or outfolded rims; the stems would have been inserted into a polycandelon (see, for example, Sterrett-Krause 2017, 56, Fig. 6; Foy 2003, 81–83). Rounded rims are found on lamps, beakers and goblets. The goblets usually have an attached

base and may also have been used as lamps (Figure 17.3; see, for example, Foy 2003, 75–77; Sterrett-Krause 2017, 62, Fig 9.49–57); occasionally the base is shaped by indentation (see, for example, Foy 2003, 78; Fünfschilling 1999, 495, Abb. 14; Sterrett-Krause 2017, 62, Fig. 9 65–84).

Some initial observations can be made about the distribution of glass finds. Conical lamps with a cracked-off rim and beaker-shaped lamps with handles are found in the church, the walled cemetery and the outer cemetery, as are lead wick holders, which could have been used with different lamp types (see Figure 18). Strikingly, stemmed lamps are only found inside the church where presumably they would have been inserted into a polycandelon hanging from the ceiling and used to light the church. Bottles and jugs (e.g., Foy 2003, 72, Figs 39 and 40) are mainly found in the church and in the outer cemetery, but are rare. Goblets are found in the church as well as in the walled

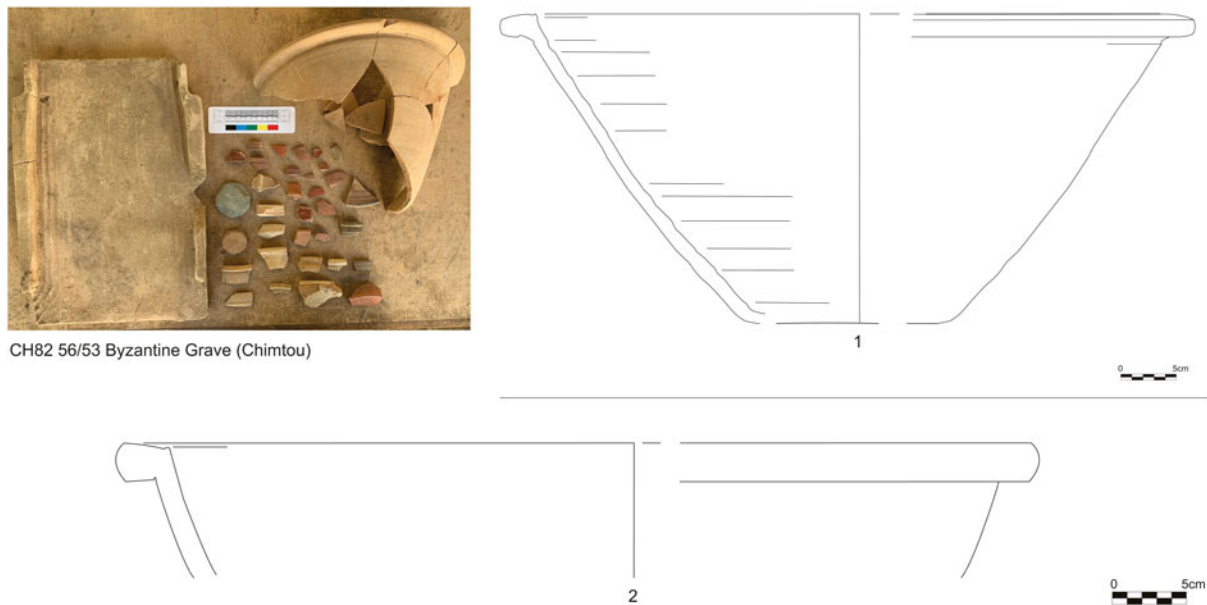

Figure 16. A comparison of bowls found in Christian contexts at Chimtou and Bulla Regia (DAI/INP, Chimtou-Project and INP/UCL, Bulla Regia Project)

cemetery, but not so far in the outer cemetery. A comprehensive evaluation of the glass finds will show whether the spatial patterning suggested can be confirmed and whether further insights can be gained.

The human remains

The bioarchaeological study of human skeletal remains includes material excavated in 2010 by the INP, as well as material excavated during the 2017–2019 field seasons, from four areas inside and around the basilica: the mausoleum, cemetery enclosure, church, outer cemetery, as well as an early Roman cemetery enclosure to the west of the church (see Chaouali *et al.* 2018).

A total of 117 human skeletons have thus far been studied (Table 1; 2 individuals are not included in the table due to poor preservation). Males and females are equally represented, with 35 males and 34 females preserved well enough to estimate sex. Of the adult individuals who could be classified into broad age categories, 58.2% had an age-at-death of less than 35 years, 31.3% died between 35–50 years and 10.4% were older than 55 years. For juveniles, the demographics of the assemblage are 33.3% less than 3 years, 41.7% between 3 to 11 years and 25% from 12 to 18 years. Thus far, the only clear distinction between the different areas of the cemetery

is that a greater number of young adults are buried in the early Roman cemetery enclosure than in the Late Antique church cemetery, with very few middle- and old-aged adults. This may be indicative of improved living conditions at Bulla Regia in late antiquity in comparison with the early Roman period.

Table 2 gives the number of individuals that exhibited the most common pathological lesions and so-called non-specific stress markers. One female individual (Skeleton 95), excavated in 2010 in the walled enclosure, had two fully fused cervical vertebrae (axis and C3). The complete fusion characterised both the body as well as the spinous and transverse processes (Figure 19). There was no evidence of trauma on these skeletal elements that may have produced the fusion as a secondary response. It appears that the two vertebrae were congenitally fused and the individual probably suffered from Klippel-Feil syndrome, a rare disorder affecting 1 in 30,000–40,000 births in contemporary populations (González-Reimers *et al.* 2001), seen more commonly in females (Nouri *et al.* 2019).

Enthesal changes (ECs) are alterations on the bone surface at the sites of muscle attachments, where new bone is either formed or resorbed in response to the size and strain of mechanical stress acting upon it. ECs are often used as skeletal manifestations of activity, based on the premise that individuals with more

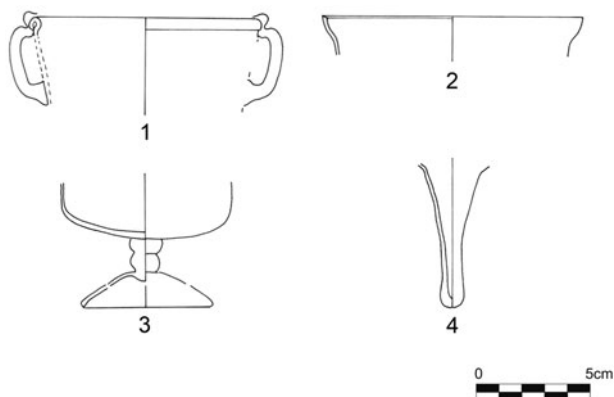

Figure 17. 18.1–3: Lamp with outfolded rim and handles, lamp (?) with cracked-off rim and goblet, all found in the walled cemetery (Z2 US6); 18.4 stemmed lamp found in the church behind a column during cleaning (1000). Scale is 1:3.



Figure 18. Lead wick holder found in church (INP 2010 excavations, Z3, S2) (Letty Ten Harkel).

Table 1. Number of individuals per age-at-death, sex and depositional area

Depositional area	Infant	Child	Adolescent	Males				Females				Indeterminate			
				YA	MA	OA	A	YA	MA	OA	A	YA	MA	OA	A
Mausoleum	0	0	3	1	0	0	0	1	0	0	0	0	0	0	0
Cemetery enclosure	7	2	1	3	4	2	0	4	2	1	0	0	0	0	1
Church	0	2	1	2	2	0	0	0	1	0	1	1	0	0	2
Outer cemetery ¹	4	8	2	3	5	2	1	6	3	1	3	2	0	0	2
'Pagan' cemetery ²	1	3	2	7	1	0	2	7	3	1	0	2	0	0	0
Total	12	15	9	16	12	4	3	18	9	3	4	5	0	0	5

¹The outer cemetery also included a subadult skeleton without further narrowing of the age range being possible due to very poor preservation.

²The 'Pagan' cemetery included one individual of unknown sex and age due to poor preservation.

Table 2. Number of individuals with different palaeopathological lesions per depositional area

Depositional area	Cribriform orbitalia	Porotic hyperostosis	Dental caries	Dental calculus	Enamel hypoplasias	Periodontal disease	AMTL	Osteoarthritis	Vertebral osteophytosis	Schmorl's nodes	Fractures	Periostitis	Exostosis
Mausoleum	1	1	1	4	3	1	0	0	0	0	0	0	0
Cemetery enclosure	1	2	7	7	6	4	7	7	5	5	1	2	2
Church	0	2	3	4	5	3	2	5	6	5	3	1	1
Outer cemetery	2	2	9	14	14	7	7	10	9	5	1	6	2
'Pagan' cemetery	5	5	8	16	10	3	5	6	7	1	3	7	1
Total	9	12	28	45	38	18	21	28	27	16	8	16	6



Figure 19. Fully fused cervical vertebrae (axis and C3) of adult female (Skeleton 95) (Efthymia Nikita).

pronounced changes probably engaged in more strenuous repetitive activities (Havelková *et al.* 2011; Lieverse *et al.* 2009). While several studies have stressed the critical role of age and body size in the expression of these changes (e.g., Michopoulou *et al.* 2015), recent evidence supports their potential as occupational indicators (Karakostis *et al.* 2019). Percent frequency of males with EC changes in the upper limbs exceeds that of females in all bones and for both sides of the body. It seems that males probably engaged in more mechanically stressful upper limb activities than females, and there is no clear pattern suggesting a systematic overuse of one side of the body.

Analysis of human dental calculus

Analysis of dental calculus (mineralised dental plaque) is increasingly popular in bioarchaeology, due to the great variety of micro-particles and molecules that are preserved in its matrix (Radini *et al.* 2017). Previous studies of dental calculus samples in Africa have focused on a small number of prehistoric individuals (Buckley *et al.* 2014). Since 2018 a systematic programme of sampling and analysis of dental tartar has been undertaken as part of the ‘A taste of hard work’ project, funded by the Wellcome Trust. Following decontamination, analysis of the microparticles in dental tartar from Bulla Regia was conducted on over 25 samples with a combination of Light Microscopy, SEM/EDX and micro-Raman Spectroscopy, in order to fully characterise the remains found (Cristiani *et al.* 2016). Preliminary analysis has revealed that the individuals were exposed to textile fibres including wool, flax/hemp and potentially even silk, as well as tree-pollen from olives and palms, both of which are still present in modern vegetation. Dietary remains show the ubiquity of starch granules across the assemblage, which suggests that a variety of starchy foods were consumed including wheat/barley (tribe *Triticeae*), legumes (tribe *Fabeae*) and millets (from at least two tribes of *C4* plants, *Panicaceae* and *Andropogoneae*). Analysis is ongoing and will be published in full elsewhere.

Isotopes

Multi-isotopic analysis has been conducted across the burial population of Bulla Regia to explore the dynamics of mobility and diet by sex, age, status and phase. Our recently published strontium ($^{87}\text{Sr}/^{86}\text{Sr}$) and oxygen ($\delta^{18}\text{O}$) isotope results from tooth enamel from 27 individuals have revealed that a high proportion of people buried at Bulla Regia did not spend their childhood there (Nikita *et al.* 2023). Of the burials analysed, seven of 22 Late Antique individuals and one of five Roman individuals were potentially non-locals. The isotopic values for non-locals probably indicate inter-regional mobility within northern Tunisia rather than long-distance migration. Non-locals from

the Late Antique phase tended to be those buried in privileged tombs within funerary chapels at the site, which could reflect the mobility of wealthy town dwellers in the region in this period, perhaps along the Carthage-Hippo route.

Previous dietary isotope studies from Roman and Late Antique populations from Tunisia, although limited in number, have hinted at a diversity in subsistence strategies during late antiquity, particularly related to the consumption of aquatic resources (Keenleyside *et al.* 2009, Ma *et al.* 2021). Preliminary data from bulk carbon ($\delta^{13}\text{C}$) and nitrogen ($\delta^{15}\text{N}$) stable isotope analysis of bone collagen of adults analysed from Bulla Regia so far are more in keeping with those published from Carthage (c. fifth to sixth century, Ma *et al.* 2021) rather than Leptiminus (second to sixth century, Keenleyside *et al.* 2009) in that there is little evidence for marine protein consumption. Analysis of further individuals and contemporary animal remains is ongoing and further research will explore dietary biographies through analysis of tooth dentine.

Conclusion

Excavations at Bulla Regia have yielded finds and preliminary data which begin to address questions about the lives and deaths of a Christian community in Late Antique North Africa. A final planned field season, long delayed by Covid-19, will further clarify the relationships between the church and cemetery, tomb construction and phasing, and the shift from pagan to Christian funerary practices in the town. In-depth analysis of the human remains is under way, looking at the patterns of mobility, kinship, ancestry and diet, including bimolecular analysis of stable isotopes, dental calculus and ancient DNA.

Acknowledgements. We acknowledge, in particular, the permission and support of the Institut National du Patrimoine and its Director, Prof. Faouzi Mahfoudh and the financial support of the British Institute for Libyan and Northern African Studies for this Flagship Project. We are also very grateful to the Garde Nationale of Jendouba, who ensured our security in the field. Efthymia Nikita’s contribution to this research was supported by the European Regional Development Fund and the Republic of Cyprus through the Research Promotion Foundation (People in Motion project: EXCELLENCE/1216/0023). Anita Radini’s contribution was supported by the Wellcome Trust (‘A taste of work’: Grant Number 209869/Z/17/Z). Field seasons took place in 2017 (7–22 September), 2018 (5–28 September) and 2019 (5 September–5 October) with the following team: Sihem Aloui Naddari (University of Tunis), Walid Ammouri (INP), Amira Absidi (University of Tunis), Mehdi Arifa (University of Tunis), Dr Dirk Booms (Assistant Director, Roman architecture specialist), Mahres Brinsi (archaeologist, INP), Armina Ben Rbeh (University of Tunis), Rayhen Boukil (University of Kairouan) Dr Gabriella Carpentiero (building specialist, University of Siena), Dr Moheddine Chaouali (Co-Director, INP), Najd Chalhouni (anthropologist, INP), Dr Samantha Cox (anthropologist, UPenn), Malek Dhaouia (University of Jendouba), Jacopo Dolci (archaeologist, Milan), Dr Corisande Fenwick (Co-Director, UCL), Olfa Gorgueb (anthropologist, INP), Guy Hopkinson (GIS specialist, UCL), Dr Gaygysz Jorayev (photogrammetry specialist, UCL), Raluca Lazerescu (archaeologist, UCL), Marie Middleton (archaeologist, UCL), Rihab Mzoughi (University of Tunis), Manel Nasri (University of Tunis), Dr Efythmia Nikita (anthropologist, Cyprus Institute), Marie Pype (archaeologist), Dr Anita Radini (dental calculus, York), Dr Nicholas Ray (archaeologist, University of Leicester), Dr Aleida Ten Harkel (archaeologist, University of Oxford), Sonia Wertani (University of Tunis), Fouzia Zoghalmi (University of Tunis). Our work was facilitated by a team of 18 workmen managed by Mounir Abidi and our food provided by Olfa Abidi. Isotopic analysis took place at BioArCh at the University of York by Alice Di Muro and Prof. Michelle Alexander with the support of Matthew Von Tersch (mass spectrometry). Finds analysis took place in 2022–2023 by Dr Heike Möller (ceramics, DAI-Berlin) and Dr Constanze Höpken (glass, Köln). We are grateful to Dr Tom Fitton for his assistance with plans and figures.

References

- Andreoli, M. and Polla, S. 2019. La ceramic domestica. In: Vos Raaijmakers, M. and Maurina, B. (eds), *Rus Africum IV. La fattoria bizantina di Ain Wassel, Africa Proconsularis (Alto Tell, Tunisia)*. Archaeopress, Oxford: 149–244.
- Bonifay, M. 2004. *Études sur la céramique romaine tardive d'Afrique*. BAR (Archaeological Reports International Series 1301), Oxford.
- Buckley, S., Usai, D., Jakob, T., Radini, A. and Hardy, K., 2014. Dental calculus reveals unique insights into food items, cooking and plant processing in prehistoric central Sudan. *PLoS One*, 9(7).
- Carton, L. 1890a. La nécropole de Bulla Regia. *BAC*: 149–226.
- Carton, L. 1890b. Les nécropoles païennes de Bulla Regia. *RA* 1: 16–28.
- Carton, L. 1909. Note sur les fouilles exécutées en 1909 dans les thermes publics de Bulla Regia. *CRAI* 53(8): 581–89.
- Carton, L. 1915. Découvertes faites en 1914 dans les fouilles de Bulla Regia. *Bulletin archéologique du Comité des travaux historiques et scientifiques* 1915: 184–208.
- Carton, L. 1922. Les fouilles de Bulla Regia au printemps de 1922. *Comptes rendus de l'Académie des Inscriptions et Belles-Lettres* 66(5): 326–33.
- Chaouali, M. 2019. La nouvelle église ouest de Bulla Regia et les évêques Armonius et Procopius. In: R. Bockmann, A. Leone and P. von Rummel (eds) *Africa-Ifriqya: Cultures of Transition in North Africa between Late Antiquity and Early Medieval* Wiesbaden, Harrassowitz: 173–82.
- Chaouali, M., Fenwick, C. and Booms, D. 2018. Bulla Regia I: a new church and Christian cemetery. *Libyan Studies* 49: 187–97.
- Cristiani, E., Radini, A., Edinborough, M. and Borić, D., 2016. Dental calculus reveals Mesolithic foragers in the Balkans consumed domesticated plant foods. *Proceedings of the National Academy of Sciences* 113(37): 10298–303.
- Fenwick, C., Dufton, A., Ardeleanu, S., Chaouali, M., Möller, H., Pagels, J. and Von Rummel, P. 2022. Urban transformation in the Central Medjerda Valley (north-west Tunisia) in late antiquity and the middle ages: A regional approach. *Libyan Studies* 53: 142–60.
- Foy, D. 2003. Le verre en Tunisie: l'apport des fouilles récentes tuniso-françaises. *Journal of Glass Studies* 45: 59–89.
- Foy, D. 2011. Les porte-mèche des lampes en verre de l'antiquité tardive. *Provence historique, Hommages à Jean Guyon*, LXI, fasc. 243–44, janvier–juin 2011 : 207–39.
- Fünfschilling, S. 1999. Gläser aus den Grabungen des Deutschen Archäologischen Instituts in Karthago. Die Grabungen 'Quartier Magon' und Rue Ibn Chabâat sowie kleinere Sondagen. In: Rakob F (ed.) *Die deutschen Ausgrabungen in Karthago (Karthago III)*, Philipp von Zabern, Mainz: 435–529.
- González-Reimers, E., Mas-Pascual, A., Arnay-De-La-Rosa, M., Velasco-Vazquez, J. and Jiménez-Gómez, M.C. 2001. Klippel-Feil syndrome in the prehispanic population of El Hierro (Canary Islands). *Annals of the Rheumatic Diseases* 60: 173–17.
- Havelková P., Villotte S., Velemínský P., Poláček L. and Dobisková M. 2011. Enthesopathies and activity patterns in the early medieval great Moravian population: evidence of division of labour. *International Journal of Osteoarchaeology* 21: 487–504.
- Hayes, J. W. 1972. *Late Roman Pottery*. British School at Rome, London.
- Jennings, S. 2006. *Vessel glass from Beirut. BEY 006, 007, and 045*. American University of Beirut, Beirut.
- Karakostis, F.A., Wallace, I.J., Konow, N. and Harvati, K. 2019. Experimental evidence that physical activity affects the multivariate associations among muscle attachments (entheses). *Journal of Experimental Biology* 222: jeb213058.
- Keenleyside, A., Schwarcz, H., Stirling, L. and Lazreg, N.B., 2009. Stable isotopic evidence for diet in a Roman and Late Roman population from Leptiminus, Tunisia. *Journal of Archaeological Science* 36(1): 51–63.
- Lieverse A.R., Bazaliiskii V.I., Goriunova O.I. and Weber A.W. 2009. Upper limb musculoskeletal stress markers among Middle Holocene foragers of Siberia's Cis Baikal region. *American Journal of Physical Anthropology* 138: 458–72.
- Ma, Y., Bockmann, R., Stevens, S.T., Roudesli-Chebbi, S., Amaro, A., Brozou, A., Fuller, B.T. and Mannino, M.A., 2021. Isotopic reconstruction of diet at the Vandalic period (ca. 5th–6th centuries AD) Theodosian Wall cemetery at Carthage, Tunisia. *International Journal of Osteoarchaeology*, 31(3): 393–405.
- Michopoulou, E., Nikita, E. and Valakos, E.D., 2015. Evaluating the efficiency of different recording protocols for enthesal changes in regards to expressing activity patterns using archival data and cross-sectional geometric properties. *American Journal of Physical Anthropology* 158(4): 557–68.
- Nikita, E., Alexander, M., Cox, S., Radini, A., Le Roux, P., Chaouali, M. and Fenwick, C., 2023. Isotopic evidence for human mobility in late antique Bulla Regia (Tunisia). *Journal of Archaeological Science: Reports* 47: 103816.
- Nouri, A., Patel, K., Evans, H., Saleh, M., Kotter, M.R.N., Heary, R.F., Tessitore, E., Fehlings, M.G. and Cheng, J.S., 2019. Demographics, presentation and symptoms of patients with Klippel-Feil syndrome: analysis of a global patient-reported registry. *European Spine Journal* 28: 2257–65.
- Radini, A., Nikita, E., Buckley, S., Copeland, L. and Hardy, K., 2017. Beyond food: The multiple pathways for inclusion of materials into ancient dental calculus. *American Journal of Physical Anthropology* 162: 71–83.
- Sterrett-Krause, A.E. 2017 Drinking with the dead? Glass from Roman and Christian burial areas at Leptiminus (Lamta, Tunisia). *Journal of Glass Studies* 59: 47–82.
- Von Rummel P. and Möller, H. 2019. Chimtou médiévale. Les derniers niveaux d'occupation de la ville de Simitthus (Tunisie). In: R. Bockmann, A. Leone und P. von Rummel (eds) *Africa-Ifriqya: Cultures of Transition in North Africa between Late Antiquity and Early Medieval*. Harrassowitz, Wiesbaden: 185–215.