

SURFACE WAVES FOR ANISOTROPIC MATERIAL CHARACTERIZATION---

A COMPUTER AIDED EVALUATION SYSTEM

J. L. Rose, Y. Huang and A. Tverdokhlebov

Department of the Mechanical Engineering and Mechanics
Drexel University
Philadelphia, PA 19104

INTRODUCTION

Along with a wide application of nondestructive evaluation methods by ultrasonic techniques, Rayleigh surface waves are being studied for their applications in material characterization. Because surface waves can offer some sensitive measurement features of wave propagation, it is suggested that surface waves be conveniently used as an experimental technique for the solution of the inverse problem of determining elastic constants and/or other characteristics in materials [1-3]. The most common direct problem is to obtain wave propagation features by theoretical analysis, experimental measurement, or numerical calculation. A desired problem in material evaluation however, is to solve an inverse problem to find material characteristics from a set of field measurement data. In surface wave problems, the closed form solutions may not even exist for some direct problems. Moreover, often material constants collectively influence the ultrasonic wave propagation in anisotropic medium, and we can not decouple them and evaluate them individually by each single ultrasonic measurement. Therefore, a numerical computational procedure is proposed.

Emphasis in this paper is on the development of a Computer Aided Evaluation (CAE) system to determine sensitive measurement feature components in acoustic measurement vector space and to generate a material property data base and the corresponding wave propagation feature data base. Based on these two data bases, anisotropic material constants and/or inhomogeneity parameters can be evaluated numerically by a multi-dimensional interpolation method from a set of measurement wave features such as the velocities of different wave modes in multiple (known) directions, dispersion parameters of guided waves, reflection coefficients etc.

Finally, a sample result for evaluating the elastic constants of a columnar-grained Centrifugally Cast Stainless Steel (CCSS) specimen (a transversely isotropic medium) by multi-directional measurements of surface wave velocity is explored.

COMPUTER AIDED EVALUATION SYSTEM

Physically, wave propagation features are determined by material characteristics. Therefore, if given the material characteristics, it is easy to obtain wave propagation features by theoretical analysis, experimental measurement, or numerical calculation though some times the procedure may be lengthy and complicated. Schematically, the dependency of wave propagation features on material characteristics may be expressed by:

$$\begin{cases} f_1 (F_1; E_1, E_2, \dots , E_n) = 0 \\ f_2 (F_2; E_1, E_2, \dots , E_n) = 0 \\ \dots \\ f_m (F_m; E_1, E_2, \dots , E_n) = 0 \end{cases} \quad (1)$$

where $E_i, i = 1, 2, \dots, n$ are n material characteristic variables, $F_i, i=1, 2, \dots, m$ are m measurements of wave propagation features where m may be much larger than n , f_i are functions that relate the corresponding wave feature and material characteristic variables in various forms. What we propose to do in this system is to solve n independent simultaneous equations which are appropriately selected from the above m equations for n material characteristic variables $E_i (i = 1, 2, \dots, n)$.

To minimize the efforts, analyses are needed to divide the equations into decoupled groups if possible. For example in the case that F_1 and F_2 are dependent only on E_1 and E_2 , Eq. (1) can be rewritten as two sets of equations:

$$\begin{cases} f_1 (F_1; E_1, E_2) = 0 \\ f_2 (F_2; E_1, E_2) = 0 \end{cases} \quad (2)$$

$$\begin{cases} f_3 (F_3; E_1, E_2, \dots , E_n) = 0 \\ f_4 (F_4; E_1, E_2, \dots , E_n) = 0 \\ \dots \\ f_m (F_m; E_1, E_2, \dots , E_n) = 0 \end{cases} \quad (3)$$

which are easier to attack since Eq. sets (2), (3) are of lower order than Eq. set (1).

Once the decoupling of the equation system is accomplished, the system can be reduced to its lowest possible order containing, for example, k material constants. Then k independent features out of the m features should be appropriately selected to obtain a system of k equations as:

$$\begin{cases} f_1 (F_1; E_1, E_2, \dots , E_k) = 0 \\ f_2 (F_2; E_1, E_2, \dots , E_k) = 0 \\ \dots \\ f_k (F_k; E_1, E_2, \dots , E_k) = 0 \end{cases} \quad (4)$$

In case analytical forms of the functions f_i are available, with a set measured feature values $F_i (i=1, 2, \dots, k)$ the corresponding set of material characteristic variables $E_i (i=1, 2, \dots, k)$ can be solved either analytically or in most cases iteratively on a computer. Similar ideas to those discussed here have been used in some published research [3-6].

In many situations, a closed form expression of the function f_i is not readily available, hence we can not find the analytical form f_i^{-1} . Moreover, often material constants collectively influence the ultrasonic wave propagation in anisotropic medium. We can not decouple them and evaluate individually by a single ultrasonic measurement. Therefore a Computer Aided Evaluation (CAE) system is proposed for this research. The correspondence between the measurements and the set of the material constants may be expressed as a vector form:

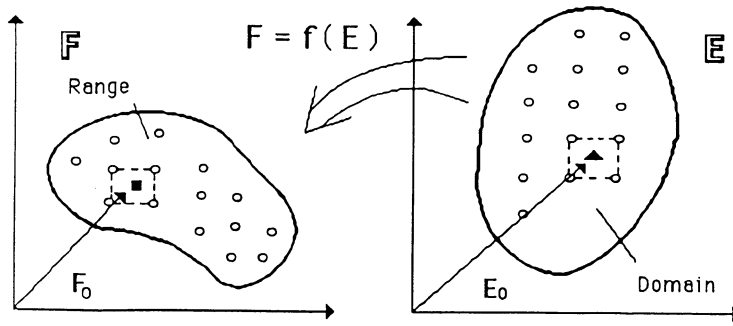

Fig. 1. Mapping of material characteristic space \mathbb{E} onto wave propagation feature space \mathbb{F} ; and determination of vector \mathbf{E}_0 by interpolation method based on a specific field measurement vector \mathbf{F}_0 . In this Figure, \circ represents the vector stored in data bases, \blacksquare represents a field measurement vector \mathbf{F}_0 , and \blacktriangle represents a resulting material characteristic vector \mathbf{E}_0 which is the original image of \mathbf{F}_0 .

$$\mathbf{F} = \mathbf{f}(\mathbf{E}) \quad (5)$$

Equation (5) represents a mapping of a vector space \mathbb{E} onto a vector space \mathbb{F} as shown in Figure 1. In space \mathbb{E} a finite, large number of vectors may be selected and experiments or especially numerical calculations may be performed to obtain their image vectors in space \mathbb{F} . The resulting correspondence is stored in a computer in the form of a data base and will be used for actual material characterization.

To determine the n material constants of a material in the same category as the material of the data base, a set of n features are selected and measurements of them are obtained from field inspection. The result obtained can be considered as a vector \mathbf{F}_0 in an n dimensional subspace of \mathbb{F} . In general \mathbf{F}_0 is not one of the vectors stored in the data base, however, several vectors in a neighborhood of \mathbf{F}_0 can be easily chosen and their original images in space \mathbb{E} can be obtained from the data base. Then certain multi-dimensional interpolation technique can be used to determine the original image of \mathbf{F}_0 . The resulting vector \mathbf{E}_0 can be considered as the material constants to be evaluated. The concept is illustrated in Fig. 1 schematically. Finally, we can use these resulting material constants as input values to calculate the corresponding acoustic feature values. The comparison between the calculation values of acoustic features and the experimental measurements of them will tell us how accurate the evaluated material constants are.

NUMERICAL EVALUATION SOFTWARE

Formulation of the Problem and Software Development

A computer program has been written to calculate surface wave propagation in a half space. The traction-free surface may take an arbitrary orientation other than coincide with any crystal plane of the material. In the program, Euler angles are used to identify the traction free surface and wave propagation direction in the free surface. A plane wave form solution below is assumed

$$\mathbf{u}_k = \alpha_k \exp \{ i P(\mathbf{n} \cdot \mathbf{r}) \} \exp \{ i [Q(\mathbf{e} \cdot \mathbf{r}) - \omega t] \} \quad (6)$$

where α_k is the displacement vector, vector \mathbf{n} is the normal vector of an arbitrarily oriented free surface, vector \mathbf{e} is the propagation direction of the surface wave in the free surface, Q is the magnitude of the propagation vector in the free surface, P is the decay

$\omega/Q = v$ is the phase velocity. To be the solutions of the surface wave, the quantity P in each of the terms of the solution must be such that the amplitudes of all the displacement components vanish as $(\mathbf{n} \cdot \mathbf{r})$ approach to $-\infty$.

We utilized the approach which combined the equations of the motion and the stress-free boundary condition into a system of equations to solve for the phase velocity of the surface wave. An extended bisection method was used to search the slowness value of the surface waves Q ($Q = 1/v$) on a complex plan, so that the phase velocities of surface waves propagating along any direction in an arbitrary free surface of a half-space of a general anisotropy medium could be determined.

The Computation of Two Data Bases and Multi-dimension Interpolation

A computer program to map a material property vector to a surface wave propagation feature vector needs to be developed, while another program to compute an inverse image point in the material data base from a given point surrounded in the wave propagation feature data base by a multi-dimension interpolation method needs also to be developed in this CAE system.

Finite Element Method Code

Another potentially powerful approach to the material characteristic evaluation makes use of a Finite Element Method (FEM) code. Though the FEM approach has not been applied to NDT extensively, a few publications [8-11] show that this method can benefit the NDT researches in a variety of problems, especially those involving not only material anisotropy but also inhomogeneity. Fig. 2 are the results of a sample run by a finite element code. This example shows that FEM has the capability to simulate the ultrasonic wave propagation in an anisotropic and/or inhomogeneous medium. We can use this code to find the sensitive measurement features and generate the wave propagation feature data base for some advanced material such as a layered medium.

AN APPLICATION EXAMPLE OF THE CAM SYSTEM

The Specimen and the Experiments

An application of the computer aided evaluation system to evaluate a Centrifugally Casting Stainless Steel (CCSS) structure was carried out in this research. The specimen "F" is composed of two different structures. The side A is a columnar-grained CCSS, while the side B is a equiaxial one. The measurements along five different directions on the top surface and the lateral surface of side A with the columnar structure were carried out (see Fig. 3a). The experimental results in Fig. 3b show that 1) There is no substantially dependency of surface wave velocity on the propagation direction on the top surface of side A of specimen "F", hence, the anisotropy director can be considered to be normal to the top surface. 2) There is a dependency of surface wave velocity on the propagation direction on the lateral surface of the columnar structure of specimen "F".

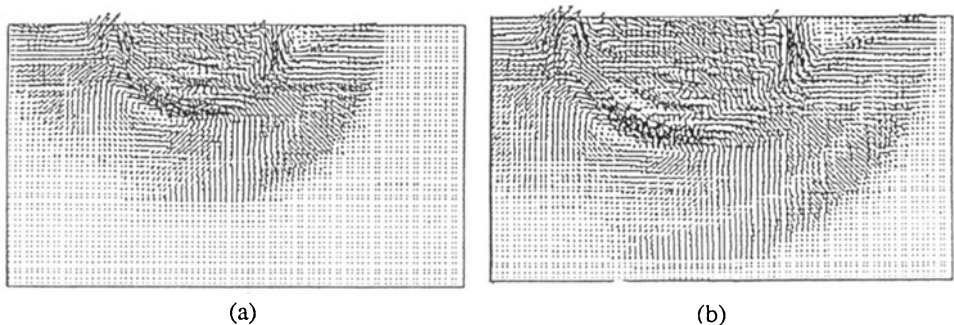

Fig. 2. Finite element simulation of wave propagation. (a) Velocity field distribution at $t = 60 \mu s$. (b) Velocity field distribution at $t = 60 \mu s$. Longitudinal wave, shear wave, surface wave and head wave are all seen clearly on these vector plot.

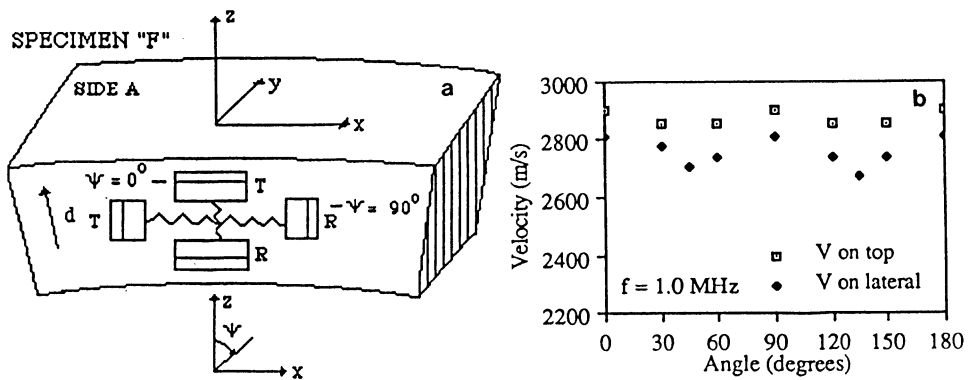

Fig. 3. (a) Experimental Configuration for measurements along 5 different directions on the lateral surface of the columnar-grained side of specimen "F". (ψ is the azimuthal angle of propagation, d is the anisotropy director) (b) Experimental results of surface wave velocity versus the azimuthal angle of propagation on the top and lateral surface of specimen "F".

Material Constants (C_L , C_T , E , S , B)

For simplicity, in this research we used another five parameters (C_L , C_T , E , S , B) taken from Ref.[7] instead of the traditional independent elastic constants (C_{11} , C_{33} , C_{12} , C_{13} , C_{44}) to describe the elastic properties of a transversely isotropic medium. The material constants C_L , C_T , E , S , and B are the combinations of elastic constants of a transversely isotropic material as shown below:

$$C_L = \sqrt{\frac{C_{11}}{\rho}}, \quad C_T = \sqrt{\frac{C_{44}}{\rho}},$$

$$S = (C_{33} - C_{11}) / \rho, \quad B = (C_{66} - C_{44}) / \rho,$$

$$E = \left(\frac{C_{13} + C_{44}}{\rho} \right)^2 - \left(\frac{C_{11} - C_{44}}{\rho} \right)^2 - \frac{(C_{11} - C_{44})(C_{33} - C_{11})}{\rho^2} \quad (7)$$

where ρ is the density of material.

The Determination of the Components of Space F and E

A parametric study has been carried out for a columnar grained CCSS (a transversely isotropic material) by using the program we developed. The numerical results (Fig. 4) show that 1) the surface wave velocity on the (x, y) plane which is perpendicular to the axis of symmetry and along the azimuthal angle 0° , 45° , 90° on the (x, z) or (y, z) plane which is parallel to the axis of the symmetry are sensitive to the variation of material constants C_T , E , S , and B . 2) Material constants C_T , E , S all collectively affect the surface wave velocity along the azimuthal angle 0° , 45° on the lateral surface and the surface wave velocity on the top surface.

Evaluation of Material Elastic Constants

For simplicity, we assume that side A of specimen "F" is a homogeneous and transversely isotropic medium. The evaluation procedure for inspection of the material constants of this sample can be performed as following:

- 1) Since the anisotropy director was assumed along the radius direction of the pipe

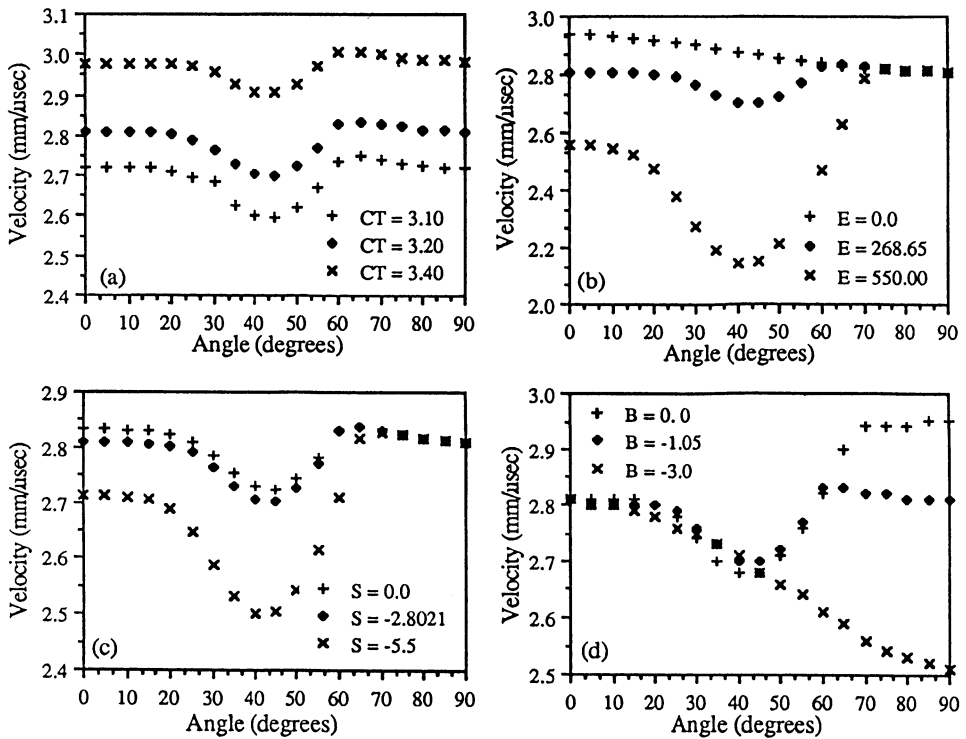

Fig. 4. Wave velocity versus azimuthal angle of surface waves propagating in xz plane which is parallel to the axis of symmetry for three different values of parameters (a) C_T , (b) E , (c) S , and (d) B in a columnar-grained CCSS structure.

we can easily determine the parameter C_L by measuring the longitudinal wave velocity along the longitudinal direction of pipe using either a critical angle technique or bulk wave technique, so that $C_L = 5.66 \text{ mm}/\mu\text{sec}$.

2) From the inspection of the calculated results in Fig. 4b, and c, when the azimuthal angle of surface wave propagation in the lateral plane is greater than 70° , the surface wave velocities do not change with the variation of E and S . And, calculation results show that the surface wave velocities in the top surface do not substantially depend on parameter B either. So the value of parameter B could be determined alone by fitting the calculation velocity of surface waves along the 90° which is the direction perpendicular to the columnar grains in the lateral plane to the measurement value ($2.810 \text{ mm}/\mu\text{sec}$) at the same direction by using a bisectional technique. Then, $B = -1.05 (\text{mm}/\mu\text{sec})^2$ was determined.

3) The values of the parameters C_T , E and S were determined by the CAE system from a given set of the experimental measurement data ($V^{\text{top}} = 2.824 \text{ mm}/\mu\text{sec}$, $V(\theta = 0^\circ) = 2.810 \text{ mm}/\mu\text{sec}$ and $V(\theta = 45^\circ) = 2.670 \text{ mm}/\mu\text{sec}$). A computer program has been written to map a material property vector with three material constants (C_T , E , S) as three components in E space to a surface wave propagation vector with the velocities along three different directions (V^{top} , $V(\theta = 0^\circ)$, $V(\theta = 45^\circ)$) as three components (see Fig. 5a). The range of each component of material property space was derived at 10 intervals. For any values of (C_T , E , S), the velocities of the surface wave (V^{top} , $V(\theta = 0^\circ)$, $V(\theta = 45^\circ)$) were calculated, so that two data space F and E with $11^3 = 1331$ data points in each were constructed and stored in the computer. Meanwhile another 3-dimensional interpolation program has been written to compute an inverse image point in the material data base from a given point surrounded in the wave propagation feature data base (see Fig. 5b). Finally,

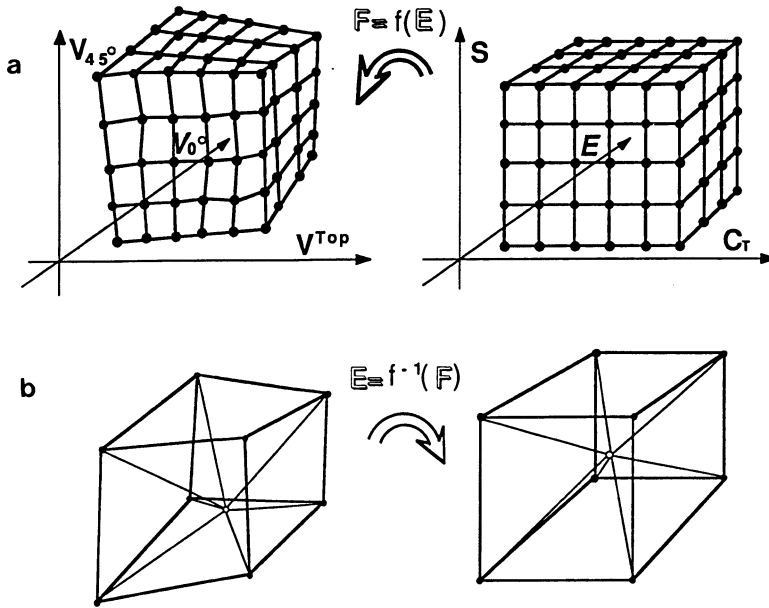

Fig. 5. (a) The mapping of the material property space \mathbb{E} with components (C_T, E, S) onto the measurement feature space \mathbb{F} with components $(V^{\text{top}}, V_{(\theta = 0^\circ)}, V_{(\theta = 45^\circ)})$ (b) The inverse mapping of a point surrounded in a cell in space \mathbb{F} back to a point in the space \mathbb{E} by a three dimensional interpolation method to determine the material constants (C_T, E, S) .

the resulting values of material constants, $C_T = 3.23 \text{ mm}/\mu\text{sec}$, $E = 273.83 \text{ (mm}/\mu\text{sec})^4$, and $S = -4.75 \text{ (mm}/\mu\text{sec})^2$ were determined.

4) We then used these resulting elastic constants as known material constants to calculate the surface wave velocities on the top surface and the lateral surface. The computational results of the surface wave velocities based on the resulting constants are $V^{\text{top}} = 2.841 \text{ mm}/\mu\text{sec}$, $V_{(\theta = 0^\circ)} = 2.812 \text{ mm}/\mu\text{sec}$, $V_{(\theta = 45^\circ)} = 2.706 \text{ mm}/\mu\text{sec}$, and $V_{(\theta = 90^\circ)} = 2.837 \text{ mm}/\mu\text{sec}$. The comparison between the given experimental data of the surface wave velocities with these corresponding calculation data shows that this calculated velocities fits the experimental data very well. Therefore it is assumed that all of the material constants were determined correctly. Then, the corresponding conventional elastic constants of the columnar grain structure are derived as $C_{11} = C_{22} = 249.91 \text{ GPa}$, $C_{33} = 212.86 \text{ GPa}$, $C_{12} = 103.51 \text{ GPa}$, $C_{13} = C_{23} = 115.60 \text{ GPa}$, $C_{44} = C_{55} = 81.35 \text{ GPa}$, $C_{66} = 73.16 \text{ GPa}$.

CONCLUSION

The CAE system proposed in this paper has been demonstrated as a useful technique for solving an inverse problem in material characterization. With the CAE system, the wave propagation feature data base which is the mapping of material property data base can be directly generated by numerical calculation, experimental measurement and finite element codes. Then, the correlated elastic constants and/or inhomogeneity parameters of the anisotropic material can be determined simultaneously from a set of directly measurable field data of wave propagation features by a multi-interpolation method. The accuracy of this technique depends mainly on 1) the error of the experimental data obtained from field

inspection; 2) the sensitivity of the acoustic features to the variation of material constants; and 3) the size of the variation intervals of each component in material property vector space.

ACKNOWLEDGMENT

The authors gratefully acknowledge the support of this work by Electric Power Research Institute Nuclear Power Division under contract #RP2405-25.

REFERENCES

1. Kaibichev, I. A., " Dispersion relation for Rayleigh waves in a medium with subsurface inhomogeneities," Sov. Phys. Acoust. Vol. 32(5), Sept.-Oct.(1986).
2. Rose, J. L., A. Plarski, and A.H. Nayfeh, " Surface waves for material characterization," to be published in the ASME Journal of Applied Mechanics.
3. Rose, J.L., and A. Plarski, " An ultrasonic NDE surface wave feature matrix technique for composites," Proceedings, Wave Propagation in Structural Composites, Mal, A.K., and Ting, T.C.T., Ed., The American Society of Mechanical Engineers, New York, NY., AMD-Vol. 90 (1988).
4. Bucur, V., and F. Rocaboy, " Surface wave propagation in wood: prospective method for the determination of wood off-diagonal terms of stiffness matrix," Ultrasonic, Vol. 26, pp. 344-347, Nov. (1988).
5. Kline, R. A., and Z.T. Chen, " Ultrasonic technique for global anisotropic property measurement in composite materials," Materials Evaluation, Vol.46, pp.986-992, June (1988).
6. Buskirk, A. C. Van, S.C. Cowin, and R. Carter, Jr., " A theory of acoustic measurement of the elastic constants of a general anisotropic solid," J. of Material Science (1986).
7. Tverdokhlebov, A., and Rose, J.L., " On green's functions for elastic waves in anisotropic media," Journal of the Acoustical Society of America, Vol. 83, pp. 118-121 (1988).
8. Temple, J.A.G., " Modeling the propagation and scattering of elastic wave in nonhomogeneous anisotropic media," J. Phys. D: Appl. Phys. (1988).
9. Sansalone, M., N.J. Carino, and N.N. Hsu, " Finite element studies of transient wave propagation," Review of Progress in ONDE, Vol. 6A, Eds., Thompson, D.O., and Chimenti, D.E., Plenum Press, New York pp.125-133 (1986).
10. You, Z., W. Lord, and R. Ludwig, " Numerical modeling of elastic wave propagation in anisotropic materials," Review of Progress in ONDE, Vol. 7A, Eds., Thompson, D.O., and Chimenti, D.E., Plenum Press, New York pp. 649-655 (1986).
11. Ludwig, R.L., D. Moore, and W. Lord, " Transducer models for the finite element simulation," Review of Progress in ONDE, Vol. 6A, Eds., Thompson, D.O., and Chimenti, D.E., Plenum Press, New York pp. 23-30 (1988).