

Dorneich, M.C., Hamblin, C., Lancaster, J., & Olofinboba, O. (2014). "Perceptual Groupings Effects on Cursor Movement Expectations," *Human Factors*. Vol. 56, No. 3, pp. 535-552.

Perceptual Grouping Effects on Cursor Movement Expectations

Michael C. Dorneich¹, Christopher J. Hamblin², Jeff A. Lancaster³, Olu Olofinboba³

¹Honeywell Laboratories. Now at Iowa State University, Ames, Iowa, USA

²Honeywell Laboratories, Olathe, Kansas, USA

³Honeywell Laboratories, Golden Valley, Minnesota, USA

Author Note

This research was funded in part by a contract with Lockheed Martin (RH6-118204).

Correspondence concerning this article should be addressed to Michael Dorneich, Iowa State University, 3004 Black Engineering, Ames, IA 50011. Contact: dorneich@iastate.edu

PRÉCIS

Two studies were conducted to understand perceptual grouping factors that drive user expectations when navigating between discrete display elements via a limited degree-of-freedom cursor control device. A rule set was developed for display format designers to leverage expectations in order to reduce navigation errors, increase usability, and decrease access time.

ABSTRACT

Objective: Two studies were conducted to develop an understanding of factors that drive user expectations when navigating between discrete elements on a display via a limited degree-of-freedom cursor control device (CCD).

Background: For the Orion Crew Exploration Vehicle spacecraft, a free-floating cursor with a graphical user interfaces (GUI) would require an unachievable level of accuracy due to expected acceleration and vibration conditions during dynamic phases of flight. Therefore, Orion program proposed using a “caged” cursor to “jump” from one controllable element (node) on the GUI to another. However, nodes are not likely to be arranged on a rectilinear grid, and so movements between nodes are not obvious.

Methods: Proximity between nodes, direction of nodes relative to each other, and context features may all contribute to user cursor movement expectations. An initial study examined user expectations based on the nodes themselves. A second study examined the effect of context features on user expectations.

Results: The studies established that perceptual grouping effects influence expectations to varying degrees. Based on these results, a simple rule set was developed to support users in building a straightforward mental model that closely matches their natural expectations for cursor movement.

Conclusion: The results will help designers of display formats take advantage of the natural context-driven cursor movement expectations of users to reduce navigation errors, increase usability, and decrease access time.

Application: The rules set and guidelines tie theory to practice and can be applied in environments where vibration or acceleration are significant, including spacecraft, aircraft, and automobiles.

Keywords: Human-computer interaction, display-control compatibility, perceptual grouping, cursor control device, Orion Crew Exploration Vehicle

Perceptual Grouping Effects on Cursor Movement Expectations

Michael C. Dorneich¹, Christopher J. Hamblin², Jeff A. Lancaster³, Olu Olofinboba³

¹Honeywell Laboratories. Now at Iowa State University, Ames, IA USA

²Honeywell Laboratories, Olathe, KS USA

³Honeywell Laboratories, Golden Valley, MN USA

Word Count: 8,883 (text), 546 (references)

INTRODUCTION

This paper describes two studies conducted to develop an understanding of factors that drive user expectations when navigating between discrete elements on a display via a cursor control device (CCD). Specifically, the research goal was to explore a user's expectations when cursor control was limited to a 2 degree-of-freedom (i.e., 4-way) or 1 degree-of-freedom (i.e., 2-way) CCD, and when cursor navigation was restricted to discrete jumps between displayed controllable elements. Controllable elements were defined as icons or alphanumeric fields on the graphical user interface (GUI) that could be controlled or manipulated by a user via the CCD.

The studies were conducted to support development of the Orion Crew Exploration Vehicle. Orion is a human-rated space vehicle that uses modern avionics, including digital displays manipulated with a CCD. Orion crews are expected to experience vibration loads greater than those experienced on any previous spacecraft. Due to the expected acceleration and vibration conditions during dynamic phases of flight, the crew will not be able to accurately use a free-floating cursor. Therefore, a "caged" cursor was proposed to achieve required accuracy levels. The caged cursor would "jump" from one controllable GUI element to another GUI element in sequential order. An example of a controllable element might be a valve icon on an Orion system display that, when selected, could be used to open or close the actual valve. In other contexts, the concept of a caged cursor is similar to a "tab" key on a standard keyboard,

which can be repeatedly pressed to jump through a series of hyperlinks on a webpage, and arrow keys on a remote control, which can be used to jump between menu items on a digital video disc (DVD). Additionally, as software displays have become more common in cars, caged cursors are becoming increasingly integrated into the automotive domain (e.g., BMW's "iDrive"). These cursors have been designed to mitigate potential user confusion in manipulating a broad array of controls, such as air conditioning, radios, and vehicle health systems.

Given the CCD's restrained degrees of freedom, display designers for Orion needed a simple set of cursor movement rules to govern the movement of the cursor between controllable elements in a predictable manner. The display layout was governed by the function and information of the system(s) being controlled, and therefore the controllable elements (or nodes) were not arranged on a rectilinear grid. This meant that expected cursor movements were not always obvious. For instance, if the user inputted an "up" on a 4-way CCD, and there was no node directly above the current node, would the cursor jump to the node that was "northeast" (i.e., up and to the right) or "northwest" (i.e., up and to the left)? Given the dynamic nature of Orion missions, it was important that the cursor movements be predictable and use of the CCD minimize error. It was hypothesized that the distance between nodes, the direction of the nodes from each other, and context features would all contribute to user cursor movement expectations when using the CCD.

While it is possible to poll users and accept the most frequent response for each node jump on each display as the "correct" cursor movement, this is not a practical solution for a variety of reasons. Such a process would be time-consuming to apply to each new GUI. Furthermore, its application would not necessarily guarantee cursor transition consistency across displays. Finally, there would be no basis for a user to develop a consistent mental model of cursor

movement with repeated use. Thus our goal was to provide Orion designers a simple set of cursor movement rules consistent with user expectations, thereby reducing navigation errors, increasing usability, and decreasing task completion time.

BACKGROUND

The design of a set of cursor movement rules was influenced by three factors. These included the operational environment of the Orion Crew Exploration Vehicle, the capabilities of the CCD input device, and the cognitive processes that might drive a user's cursor movement expectations.

Orion Crew Exploration Vehicle

In 2005, NASA embarked on the Constellation Program with the intention of developing a variety of human-rated space vehicles that would take astronauts beyond low earth orbit, returning to the moon and on to Mars as well. Although the Constellation Program has since been cancelled, elements of the program continue to be developed, including the Orion Crew Exploration Vehicle (now known as the Orion Multi-Purpose Crew Vehicle). Unlike previous spacecraft, Orion command and control is designed to be largely the responsibility of onboard crew members (astronauts), thus reducing the vehicle's reliance on ground-based mission control. To accomplish this, Orion will rely on a highly automated avionics system. In fact, during normal operations, the most dynamic phases of flight (e.g., launch and reentry) will be entirely automated, relegating the astronauts to the role of system monitors. During abnormal or emergency operations, the astronauts will be required to intervene as necessary to control the necessary systems. Orion's cockpit is designed to accommodate these disparate levels of automation with a balance of displays and controls, similar to those found on modern aircraft. Rather than interacting with a myriad of buttons, switches, knobs, dials, and circuit breakers,

Orion's astronauts are provided with a "glass cockpit," allowing the astronauts to monitor and command the vehicle's systems via approximately 80 graphics-based user interfaces depicted on computer-based display units with a small complement of manual controls for abnormal or emergency situations (NASA, 2008).

Command and control of Orion will prove most difficult during dynamic phases of flight when acceleration and vibration forces will be highest (i.e., launch and reentry). The flight environment during nominal phases of flight can include gravitational loads calculated to be as high as 3.8G during launch with perhaps higher loads during reentry (Adelstein et al., 2008). Orion crews may also experience vibration loads greater than those experienced on any previous spacecraft. While the final vibration loads have yet to be determined, analysis suggests that the loads may approach 0.25G (0-peak) (Adelstein et al., 2008). In contrast, Shuttle and Apollo limited vibration loads to 0.1G. Visual and motor performance limits are exceeded at 0.5G (NASA, 2008). Thus, there may be phases of flight when the astronauts' cognitive and physical abilities are less than optimal.

To protect the crew from these environmental conditions, the astronauts will be fully suited, seated, and restrained during dynamic phases of flight. While these conditions are obviously necessary for the safety of the crew, they create additional challenges for GUI designers. For example, the suit, seat restraints, and flail restraints used to protect the crew during launch and reentry will intentionally and severely limit the astronauts' range of motion; however, depending on the astronauts' anthropometry, these restraints may also prevent the astronauts from reaching the controls on the instrument panel. To further challenge cockpit designers, the astronauts' suits will be lightly pressurized during normal launch and reentry and

highly pressurized during abnormal and/or emergency conditions. The pressurized suits will increase the physical effort required to perform tasks and further restrict range of motion.

The extreme environmental conditions coupled with the crew's protective equipment will require a remote control device that will allow the astronauts to command and control the vehicle's systems during dynamic phases of flight. The CCD needs to allow the crew to remotely interact with the GUIs using simple finger movements, thus accommodating the crew's protective equipment while still providing command and control capabilities.

Design of the Cursor Control Device

Once the need for a CCD was identified, requirements were determined using functional and ergonomic analyses. The design of the CCD focused on reducing input errors due to the combination of task criticality with the gravitational and vibration loads discussed previously. Another concern was accommodating the use of the CCD while wearing gloves, especially when the suit is pressurized, as glove box evaluations demonstrated that tactile feedback and hand dexterity are reduced during gloved use (Boyer, Hamblin, Holden, 2008). Given these considerations, it was determined that the fine motor movements required of a free floating cursor would yield unacceptable error rates and be nearly impossible to use in flight. Thus, the decision was made to use a caged cursor movement, where the cursor jumps between the controllable elements of the display.

Once the caged cursor concept was chosen, NASA needed to determine the degrees of freedom to provide the crew a balance between freedom of movement and accuracy. Fewer degrees of freedom decrease the number of potential movement errors, but also increase access time. Conversely, more degrees of freedom increase the potential for movement errors, but decrease access time. Several studies were performed to compare performance between 1, 2, and

4 degrees of freedom (DOF) (Hamblin, Boyer & Holden, 2008; Boyer, Hamblin & Holden, 2009). Figure 1 illustrates the degrees of freedom for an 8-way, 4-way, and 2-way CCD.

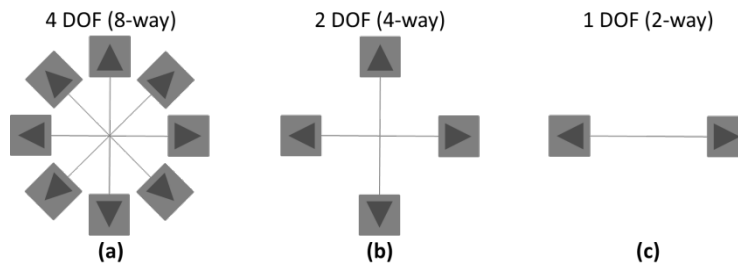

Figure 1. Degrees of freedom (DOF) for an 8-way, 4-way, and 2-way cursor control device.

Pilot studies demonstrated that cursor movement error rates with an 8-way CCD were too high, primarily due to inaccuracies in the diagonal directions (Hamblin, Boyer & Holden, 2008). Conversely, movement error rates with a 2-way CCD were almost non-existent; however, the astronauts were concerned with excessive access time (Boyer, Hamblin & Holden, 2009). The results of the pilot evaluations suggested that a 4-way cursor may provide adequate balance between error rates and accessibility.

Given the nature of Orion displays, requiring Orion display designers to arrange the controllable elements in a rectilinear grid was too restrictive. For instance, system displays are often based on schematic diagrams whose layout is governed by functional connections between system elements (e.g., batteries, valves, circuit breakers) rather than by a geometric layout optimized to support cursor movement. However, there are several human cognitive processes that explain how interface features might drive cursor movement expectations; these are described in the following paragraphs.

Cognitive Processes Driving Cursor Expectations

There are many cognitive processes that can influence user expectations regarding the behavior of an input device like a CCD. User experiences built up over time, including cultural

factors (e.g. direction of reading text), procedural behavior scripts built up in long-term memory, and mental models of interaction can all drive expectations. However, the features of the display itself can also influence cursor movement expectations. This is the focus of this paper.

In 1923, Wertheimer proposed that humans have a visual ability to extract significant relationships from an image using lower-level primitive image elements. Humans are able to group image elements to obtain a meaningful higher level structure without any knowledge of the image content (Iqbal & Aggarwal, 2001). This capability allows humans to recognize an object as a house rather than as a random assortment of “327 brightnesses and nuances of colour” (Wertheimer, 1923 as translated by Ellis, 1938, p.71). Wertheimer proposed a series of principles, the *Gestalt Grouping Principles*, to assist understanding of the different factors that influence the grouping or composition of elements into a whole, including *symmetry*, *similarity*, *proximity*, *common fate*, *good continuation*, *past experience*, *closure*, and *smoothness* (Koffka, 1935; Wertheimer, 1938, as summarized in Tuceryan & Jain, 1998). More recent work has added to these principles, including perceptual grouping principles such as *common region* (Palmer, 1992) and *element connectedness* (Palmer & Rock, 1994). Overall, the influence of these principles supports an overarching *Good Gestalt Principle*: elements tend to be grouped together if they are parts of a pattern which has a meaning that is simple, orderly, balanced, unified, coherent, and as regular as possible (Todorovic, 2008). For instance, similarity promotes coherence and regularity. Node color can also be a similarity factor (Schmidt, 2001). One or more of these principles can be at work when determining the perceived grouping, where the principles can work in concert or can compete with each other (Tuceryan & Jain, 1998).

Distance and direction (proximity principle) play a key role in influencing the speed and accuracy of cursor movements (Fitts, 1954; Fitts & Peterson, 1964; Thompson, et al., 2006);

however, it is unclear what influence they might have in terms of predicting ambiguous cursor movements. It is assumed that a user would select the optimum path to navigate from point A to point B, but what if the optimum path is not immediately evident? Thus, the influence of node distance and direction on user anticipation of cursor movements was explored in the first study of the two described in this paper.

As distance and direction also play a role in perceptual grouping (Wertheimer, 1923; Kubovy & Wagemans, 1995), context-based perceptual grouping principles such as the common region principle and the element connectedness principle, might impact cursor movement expectations. Thus, the influence of context features (e.g., boxes, connecting elements, and other visual grouping elements) on user anticipation of cursor movements was explored in the second study.

The goal of the two studies was to derive a simple set of rules governing the movement of a cursor given the user CCD input, and consistent with user expectations. GUI designers could then develop displays that meet user expectations, resulting in reduced navigation errors, increased usability, and decreased access time. To the extent that the Gestalt principles of perceptual grouping could be used to explain the expectations, the research team could be more confident that the movement design rules developed based on a limited set of displays would be generalizable to the 80 or so expected Orion display GUIs, and ultimately to GUIs incorporating discrete navigation in other domains.

STUDY 1: BASELINE CURSOR CONTROL

The baseline study evaluated the effect that relative locations of controllable elements have on a user's cursor movement expectations, independent of any contextual features in the

displays. This was motivated by Wertheimer’s original Gestalt principles, which were limited to the features of the elements themselves, and served as a baseline of user movement expectations.

In particular, the effect of node proximity was evaluated, which was operationalized as the location and distance of one node in relation to another. In this initial study, similarity was controlled by showing all nodes as either like-sized dots or squares; thus, there was no expectation that similarity would drive grouping. Since node color can also be a similarity factor, all nodes were the same color. As illustrated in Figure 2 for the set of nodes used in Trail B of the study, the set of nodes presented to participants were abstracted from real display designs, with features removed that would allow participants to call on past experience.

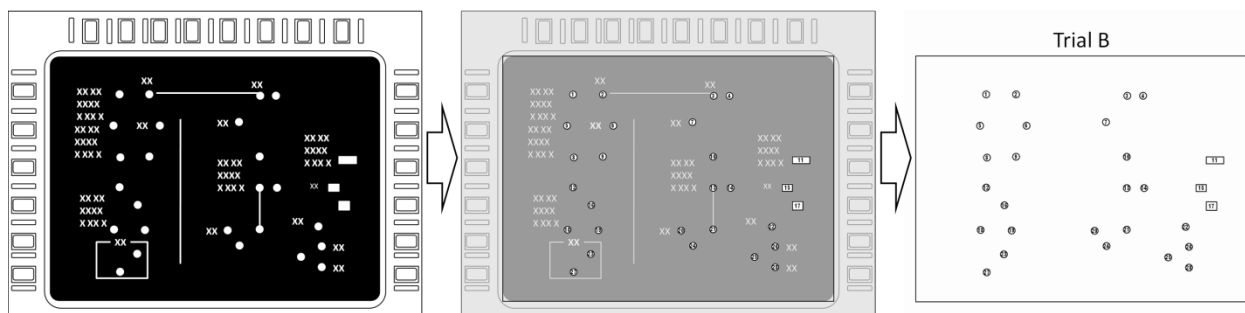

Figure 2. An Orion GUI design (left) was systematically reduced to the “controllable elements” or “nodes” (right).

Method

Objective. The objective of the study was to understand user expectations for cursor movements when the navigated nodes were arranged on a non-rectilinear grid. The results were used to develop a rule set to serve as a basis for algorithms to govern cursor response to operator inputs.

Participants and Tasks. Eleven aerospace engineers from Honeywell served as participants (nine male and two female). The participants averaged 11.6 years of professional experience (standard deviation 6.0 years, range 1-21 years). They were each given a paper-based cursor movement mapping task with four trials. Each trial represented a set of nodes on one

display. The first three trials were based on existing Orion GUI display designs (e.g. see Figure 2 for Trail B) to replicate the application domain as much as possible while still keeping the trials free of any elements (such as colors, labels, or icons) beyond the controllable elements that might drive expectations. The fourth trial was not based on an existing Orion GUI display, but rather specifically designed to study some “special cases” of node arrangements (e.g., two 45 degree diagonal options equidistant from the origin node).

The collection of nodes for each trial was constructed by removing all the graphics from the GUI except for the controllable elements, resulting in an abstracted set of nodes (see Figure 2). A 4-way CCD was chosen as an appropriate balance between reduced errors and access time.

Procedure. Participants were given the following instructions when completing their paper-based cursor movement task:

1. Assume a device that has four inputs: LEFT, RIGHT, UP, and DOWN. The device could be a gated cursor device, four arrow keys, or some other input device.
2. For each node on the display, indicate to which node a LEFT/RIGHT/UP/DOWN cursor control input would move the cursor.
3. You may not be able to use every direction for a particular node.

Participants did not use an actual CCD, but rather completed a “jump table” for each trial where they recorded the destination node for the LEFT/RIGHT/UP/DOWN cursor movements from each origin node (see Figure 3 for an illustrative example). After completing the jump tables, participants were given the opportunity to describe any heuristics or general rules of thumb that they developed or used.

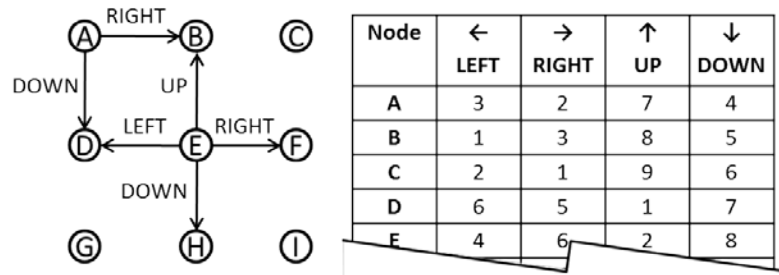

Figure 3. Sample trial (participants only saw nodes, the arrows are added to aid reader understanding) and associated jump table (not all table entries shown by arrows in the figure on the left).

Data Analysis Terminology. Two conventions were used to describe the direction of the cursor control input versus the direction of the cursor movement. The 4-way cursor control device had four possible user inputs – LEFT, RIGHT, UP, and DOWN (see Figure 4a). The directions of the resulting movement were likened to a north-up map: if the movement (from one node to another) was straight up, then the direction of the movement was defined as “north.” The other three directions followed in similar fashion (see Figure 4b). In other words, “west/east/north/south” were used to describe directions on the display, while “LEFT/RIGHT/UP/DOWN” were used to describe the four inputs on the CCD.

A *direct transition* is a cursor movement from one node to another within the boundaries of the GUI (see Figure 4c). A *wrap transition* is a cursor movement from one node to another through an edge that “came around” on a different side through the display boundary, as if it went behind the display and comes around on the other side (see Figure 4c). A *cardinal transition* is a cursor movement from one node to another where the two nodes align on the x or y axis (i.e., the transition is in the exact direction of the cursor input direction, e.g., north, east, west, south; see Figure 4d). A *non-cardinal transition* is a cursor movement from one node to another where no cardinal option exists, and thus the movement is necessarily on a diagonal (Figure 4d).

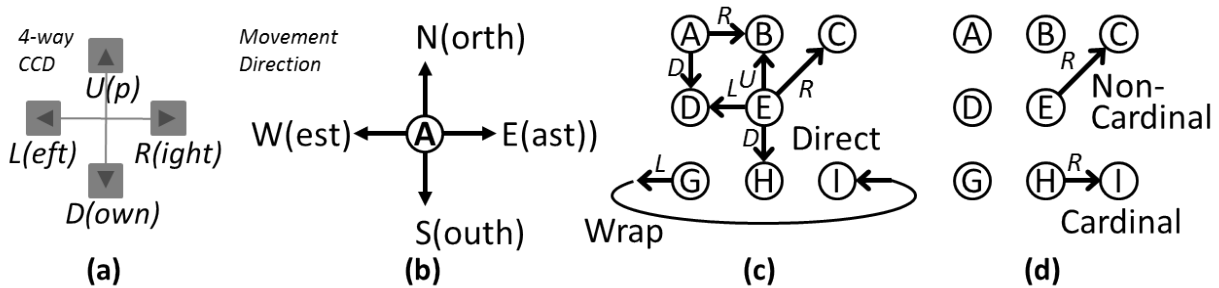

Figure 4. Nomenclature on input (a) vs. movement directions (b), direct and wrap transitions (c), and cardinal and non-cardinal transitions (d).

Data Analysis. The data analysis plan was a combination bottom-up and top-down analysis. Data were analyzed bottom-up by taking a question-based approach. Questions were asked, and the data were evaluated to determine how much of the observed results were explained by the answers. Different questions were asked until those answers which explained the majority of the transitions were identified. Example questions included the following:

- When a cardinal option existed, did participants choose it?
- For non-cardinal transitions, was there a preference of which diagonal to take?
- Are LEFT/RIGHT expectations different than UP/DOWN?
- Are wrapping expectations different than direct?

To answer these questions, data were assigned to one of four groups across two dimensions:

- Direct transitions vs. wrap transitions
- Cardinal transitions vs. non-cardinal transitions

In a top-down analysis, a threshold of agreement was identified to determine when a rule could be established. This threshold was determined by comparing how well the participants agreed with each other for all transitions. This was defined as a baseline threshold for establishing user expectations.

Limitations. There were two main limitations to the study. First, the trials did not systematically consider every possible distance/angle transition from a given node. A more systematic design would have created trials that presented an equal number of cases where the distance and angle deflection (from the intended cursor movement direction) were varied to form a set of all possible transitions. This study used Orion displays as the basis for three of the four trials. Basing the trials on these Orion displays outweighed the concern of exhaustively testing every possible transition combination.

Second, although the trials were based on Orion GUIs, all graphical elements except the controllable elements were removed because keeping any of the other graphical elements could have served to cluster nodes into subgroups. This may have driven cursor movement expectations. This limitation was the basis of the second study described in this paper.

Results

Characterization of the Data. Across the four trials, there were a total of 3025 possible transitions. The transitions were broken down into the following categories:

- 2253 direct transitions
- 292 wrap transitions
- 480 no transitions (participants left the jump table entry blank)

The number of wrap transitions was low because only four participants considered them. The instructions did not explicitly mention/demonstrate wrapping, so not all participants were aware that wrapping was a possibility. The wrapping results reported later looked at only these four participants.

Baseline Results. The data were analyzed to determine the most frequent response for each node's four cursor input possibilities (i.e., LEFT, RIGHT, UP, DOWN). This provided, at a

node-by-node transition level, a measure of consistency of the participants' answers. Considering the entire data set of all cursor movements from each participant, 81.8% of the time (2085 of 2550 transitions) participants agreed with each other on a particular node transition. For example, as seen in Table 1, when participants input a LEFT cursor control input, they jumped (moved) to the same destination node 83.9% of the time. In addition to good overall agreement, there were consistently high agreement rates for all four cursor control input directions (see Table 1).

Table 1. Level of agreement between participants for the four cursor input directions.

Cursor Input Direction	Level of Agreement
LEFT	542 of 646 (83.9%)
RIGHT	536 of 655 (81.8%)
UP	505 of 627 (80.5%)
DOWN	507 of 627 (80.9%)

On average, for each node, 9 of the 11 participants chose the same transitions. It is worth noting that those participants who chose a different node than the majority might still have chosen a node that most people would find acceptable – the majority-chosen node was just not first node of choice for the minority. Our goal was to define a cursor movement rule set that matched user expectations. Given the level of agreement shown in Table 1, a goal of 75% agreement between the users for movements was set to define the rule set for the movements of users. If a rule set could be designed that matched the baseline performance (i.e., the rule captured 75% or better of the user data), then the participants' dominant expectations were identified. Dominant expectations are a type of population stereotype, where a large proportion of a given population has a consistent expectation that is prominent within the population.

***Cardinal Transitions.** What did participants do when a cardinal option existed? For instance, what happened when a participant wanted to move the cursor right, and one of the*

possible target nodes lay directly east of his or her current node? When a direct transition was available, 93.1% (580 of 623 data points) of the time, participants selected a cardinal LEFT/RIGHT when the option existed. However, when a cardinal UP/DOWN option existed, participants took it only 54.3% (202 of 281) of the time.

For those participants who considered wrapping when a wrap cursor movement was available, participants took the cardinal LEFT/RIGHT when the option existed only 27% (34 of 126) of the time. When a cardinal UP/DOWN option existed for a wrap cursor movement, participants took it 63.8% (30 of 47) of the time.

The results suggest that there was a strong preference amongst the participants for a direct LEFT/RIGHT cardinal cursor movement over other options. However, there was no apparent preference for a direct UP/DOWN cardinal cursor movement when the option was available. Additionally, there was a strong preference against LEFT/RIGHT cardinal wrapping, and a weak preference for UP/DOWN cardinal wrapping.

UP/DOWN Transitions. *Why did participants not always take the cardinal UP/DOWN when it existed (especially since they preferred the cardinal LEFT/RIGHT)?* One possible explanation is that many cardinal options arranged north or south of a node were a far distance away, crossing “imaginary rows” (described in the next section). Thus, the dominant expectations of UP/DOWN transitions needed to be addressed.

What if, for UP/DOWN transitions, the closest node was taken (regardless of angle, as long as it lay in the hemisphere that represented the direction of input; i.e., an UP movement would look at nodes in the northern [upper] semi-circle above the node)? Data analysis revealed the following:

- 75.5% (438 of 580) of the time, participants selected the closest direct node UP (see Figure 5a for an example where the closer direct node was preferred over a cardinal, but more distant node).
- 79.8% (474 of 594) of the time, participants took the closest direct node DOWN.

The results suggest that UP/DOWN transition preference was dominated by distance.

Furthermore, there were cases when two non-cardinal destination nodes were equally distant from the origin node. If two nodes were the same distance away, participants preferred the node with the smaller relative angle deflection (from the cardinal direction). If two nodes were the same distance and angle, participants preferred the node to the left (see Figure 5b).

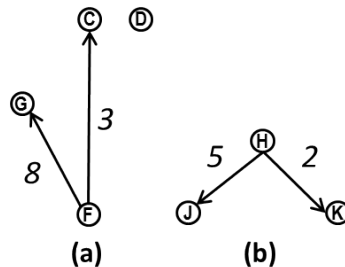

Figure 5. For an UP transition (a) at node F, closer node (labeled G) was preferred over cardinal node C. For a DOWN transition (b) with equidistant destination nodes, the left node J was preferred over the right node K. Arrows are labeled with the number of participants choosing that transition.

Wrapping Transitions. *Finally, why did participants not always take the cardinal LEFT/RIGHT wrap when it existed?* One possible explanation is that participants may have been viewing wrapping in the context of a one-dimensional device design (e.g., a rocker switch that has only two inputs) where the cursor cycles through all nodes, wrapping to the beginning of the next line down when moving RIGHT from the last node in a row. Sometimes this action is referred to as “typewriter wrapping” (see Figure 6). Data analysis revealed the following results:

- 85.5% (53 of 62) of the time, participants wrapped to the beginning of the next line with a RIGHT movement on right edge
- 79.4% (54 of 68) of the time, participants wrapped to the end of the previous line with a LEFT movement at the left edge node

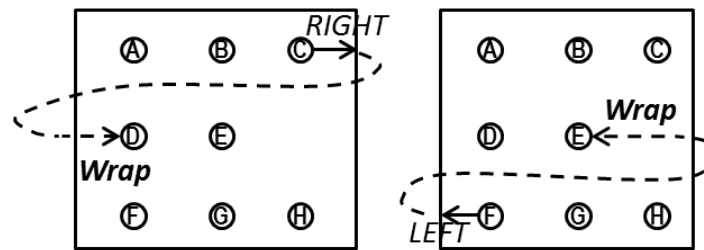

Figure 6. "Typewriter" wrapping.

The results suggest that, for these formats, LEFT/RIGHT wrapping by participants was dominated by *thinking in rows*.

Rule Set

A rule set was developed to capture what was learned in the data analysis. The rules were applied to the four trials to measure degree of fit with user responses. A high degree of fit indicated that the rule set met the dominant expectations for cursor movement. The rule set can serve as a basis for software algorithms to govern cursor response to operator inputs.

The rule set was based on a concept of pre-defined rows. A row is defined as any set of nodes arranged in a horizontal spacing, where no two nodes share the same x - (horizontal) coordinate. Another way to visualize the definition of rows is to draw horizontal lines on the display that separate rows of nodes. With this rule set, inputs resulted in the following:

- A LEFT input resulted in a transition to the node with the next smaller x -coordinate within the row (i.e., immediately to the left within the row).
- A RIGHT input resulted in a transition to the node with the next greater x -coordinate within the row (i.e., immediately to the right within the row).
- An UP input resulted in a transition to the node with the shortest distance in the next higher row.

- A DOWN input resulted in a transition to the node with the shortest distance in the next lower row.
- Note that for both UP and DOWN inputs, if there were two nodes with the same distance from the current node, then the node with the smaller angle was chosen. If the two destination nodes were the same distance and had the same angle from the current node, then the one to the left was chosen.

Figure 7 illustrates these rules (direct only, only RIGHT and DOWN movements shown).

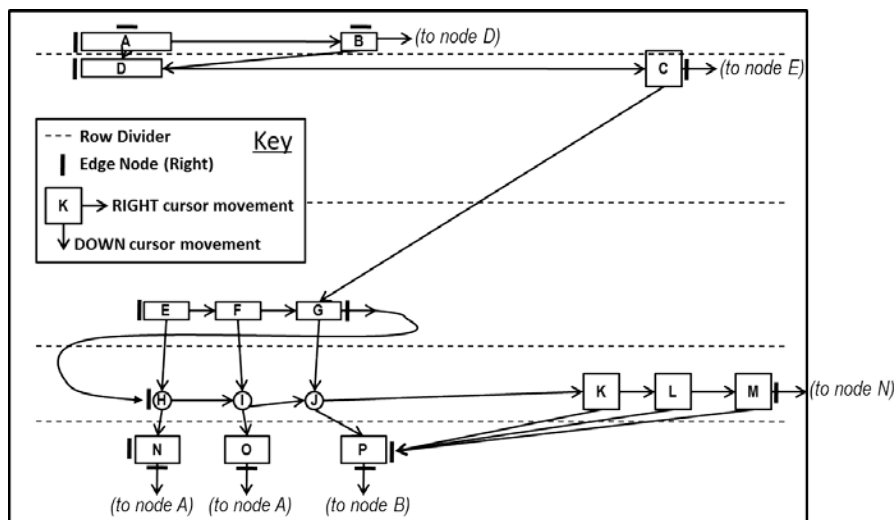

Figure 7. Rule set applied to one of the display trials (only RIGHT and DOWN inputs shown).

With respect to wrap transitions, edge nodes were defined. All nodes on the top row of the display represented the upper edge; all nodes on the bottom row of the display represented the lower edge. The nodes in each row with the smallest x -coordinate (i.e., leftmost node in each row) represented the left edge nodes, and the nodes in each row with the greatest x -coordinate (i.e., rightmost node in each row) represented the right edge nodes. This rule set included the following:

- When executing a LEFT wrap, the transition was to the rightmost (smallest x -coordinate) of the next upper row.
- When executing a RIGHT wrap, the transition was to the leftmost (greatest x -coordinate) of the next lower row.
- When executing an UP wrap, the transition was to the smallest angle of the bottom row.
- When executing a DOWN wrap, the transition was to the smallest angle of the top row.

This rule set was developed to capture as much of the observed participant transition data as possible: this accounted for 77.0% (1963 of 2550) of the observed transition results. The following were observed across all four possible cursor inputs:

- 81.0% (523 of 646) of LEFT transitions followed the rule set
- 78.0% (511 of 655) of RIGHT transitions followed the rule set
- 75.1% (471 of 627) of UP transitions followed the rule set
- 74.2% (465 of 627) of DOWN transitions followed the rule set

The rule set had a 94.2% overall match with the baseline. In addition, all four input directions showed high levels of agreement.

Discussion

It would be possible to apply the methodology outlined in this experiment to fill in the cursor jump table in Figure 3. For each new GUI, designers could poll a number of participants and accept as “correct” the cursor movement with the most frequent response for each node jump. However, this is not a practical solution for a variety of reasons. Such a process would be time-consuming to apply to each new GUI. Furthermore, its application would not necessarily

guarantee cursor transition consistency across displays. Finally, there would be no basis for a user to develop a consistent mental model of cursor movement with repeated use.

Participants reported two principal strategies when deciding to which node a cursor should jump given a CCD input. Most participants reported thinking in “rows” or “horizontal planes,” with some identifying wrapping to the next row similar to a typewriter or reading. Seven subjects reported factoring proximity and angles when making choices. Six participants stated that they favored proximity to angle (“I seem to be using a general rule of going to the nearest within a certain size cone.”), while one “favored straight shots/smaller angles over proximity to capture the node.” In cases of equidistant possible target nodes, three participants reported favoring “either the leftmost or topmost target,” and one participant reported “when there was a tie as far as distance from node, I favored up and right”.

The use of the rule set developed here ensures the following: 1) all nodes are reachable, and 2) all transitions are “undoable.” That is, if a user mistakenly enters the wrong movement, doing the reverse of the last movement would return the cursor to the previous node, thereby supporting the desirable ability of user error recovery. In addition, the simplicity of the rule set may make it relatively easy for users to develop a mental model through repeated use. Finally, this rule set is relatively easy to apply to a given GUI. The rule has a disadvantage in that it does influence GUI designers to arrange controllable elements in a quasi-row structure. A row structure is not strictly required, but the preference would be for easily identifiable rows of controllable elements. This may work well for system diagrams that are based on schematics, but this may not work as well in flight control displays, where controllable elements are less uniformly distributed within the displays. It is possible to develop another rule set based only on

node geometry (Dorneich et al., 2010); however, this rule set could not guarantee that all nodes are reachable.

Given that the rule set developed shows a high degree of match (94.2%) with the baseline, it appears that it would be a reasonable software algorithm to govern four-way cursor movement. The first study examined user expectations based on the nodes themselves. A second study then examined the effect of context features on user expectations to determine if the rule set needed to be modified.

STUDY 2: PERCEPTUAL GROUPING EFFECTS ON CURSOR MOVEMENT EXPECTATIONS

Motivation

One limitation of the previous study was that the GUIs used did not have context features such as boxes, connections, or other visual stratification elements which could drive user cursor movement expectations. Because of this, a second study was conducted to address the effect of context on user's cursor movement expectations.

More recent work in perceptual grouping has developed two additional Gestalt principles that consider features within which nodes reside, rather than features of the nodes themselves: *common region* (Palmer, 1992) and *element connectedness* (Palmer & Rock, 1994). Palmer and colleagues (1992) developed the common region principle, which states that elements located in the same closed region tend to be grouped. Thus, the area defined by a common boundary feature may drive cursor expectations. Palmer and Rock (1994) proposed the element connectedness principle, which states that elements connected by other elements tend to be grouped. The lines between nodes in system schematics can be interpreted in this way, and may drive cursor movement expectations.

Finally, it can be surmised that the distance between nodes influences whether the human visual system organizes their arrangement perceptually as rows or columns (Schmidt, 2001). Thus, while a set of nodes may share an x -coordinate (column) or a y -coordinate (rows), it is the sets that have a smaller distance between nodes that are perceived as columns (or rows), which may drive cursor movement expectations and break from the default rule set. A study was conducted that included formats with the following context features of interest:

- *Area* – a group of nodes separated from other nodes by a common boundary (e.g., a line or a box).
- *Schematic-line nodes* – a set of nodes that are connected with lines.
- *Column of nodes* – a set of nodes that line up in a natural column, usually of three or more nodes.

Modified Rule Set

As in Study 1, Study 2 focused on user cursor navigation expectations of actual Orion GUI designs. Unlike Study 1, however, user cursor navigation expectations were determined for a 2-way CCD rocker switch actuation, as this was the new design chosen by NASA. The 2-way cursor was selected because it produced the least number of errors and ultimately represented the safest and simplest solution for the engineers and the astronauts. The rule set developed in Study 1 was adapted for a 2-way CCD input, resulting in the following modified rule set:

- LEFT input resulted in a transition to the node with the next smaller x -coordinate within the row (i.e., immediately to the left within the row).
- RIGHT input resulted in a transition to the node with the next greater x -coordinate within the row (i.e., immediately to the right within the row).
- LEFT input at the leftmost node of a row resulted in a (wrapping) transition to the rightmost node in the row immediately above it.
- RIGHT input at the rightmost node of a row resulted in a (wrapping) transition to the leftmost node in the row immediately below it.

Method

Objective. The objective of the study was to understand the effect of context elements on user cursor movement expectations. The results were used to develop design guidelines that could be used in conjunction with the (modified) control rule set derived in the previous study.

Participants and Tasks. Ten participants (five male and five female) were recruited to participate in the study, all of whom were aerospace engineers. Only one of these participants also took part in Study 1. The remaining nine participants were recruited from NASA or Lockheed Martin. The participants averaged 9.6 years of professional experience (standard deviation 7.4 years, range 2-26 years).

The cursor movement study had four separate trials. Two trials were constructed using two Orion GUI designs per the same procedure as the previous study, but where context features were retained. The context features of interest included nodes grouped by *common boundary* or *area*, nodes grouped by *schematic-lines*, and *columns* of nodes grouped by proximity.

The third and fourth trials were not based on an Orion GUI design, but instead were created to include “special cases” (i.e., relatively complex node arrangements and locations). The four trials are shown in Figure 8.

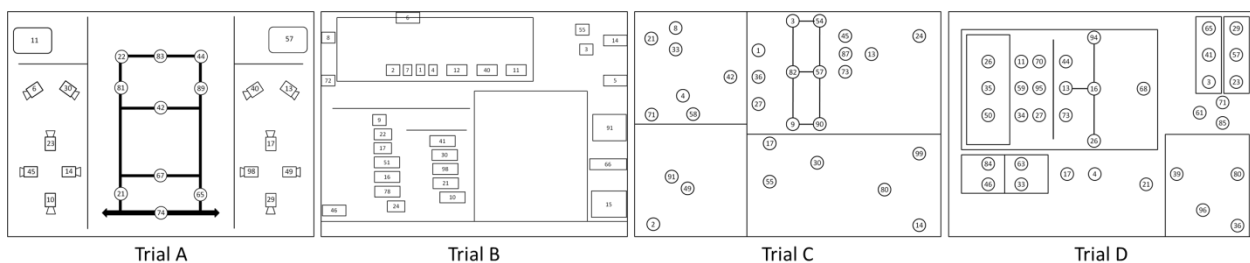

Figure 8. Trials A through Trial D for Study 2. Randomized numbers are used as node labels (used for reference in jump table).

Procedure. This study used the same procedure as the previous study; however, participants only needed to fill in two movements for each node, rather than four, due to the change to a 2-way CCD. Participants were also informed of the concept of wrapping and were instructed that they may or may not want to include it in their cursor movements. At the end of the study, participants were given the opportunity to describe their strategies, if any. Specifically, participants were asked if they were consistent through all four trials, and how area, columns, and lines affected navigation.

Data Analysis Terminology. In addition to direct and wrap transitions (defined previously), three more types of transitions were defined (see Figure 9):

- A *line transition* was defined as a cursor movement from one node to another node directly adjacent to it and connected to it via a line.
- A *column transition* was defined as a transition between one node and another in a column (i.e. up or down).
- An *internal wrap transition* was defined as a cursor movement from one node to another node through an edge of an area (defined previously as a group of nodes surrounded by a common border) that “comes around” on a different side of the same area.

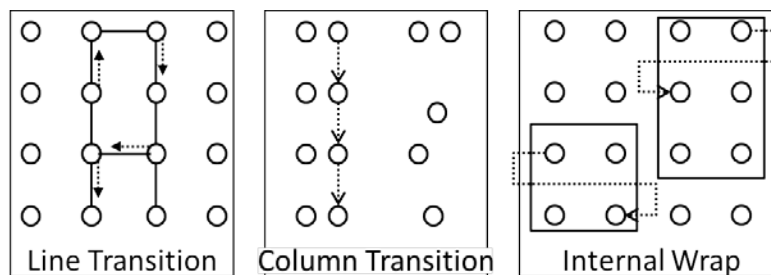

Figure 9. Nomenclature used to categorize cursor movements.

Data Analysis. As in the previous study, the current analysis considered the threshold for a cursor navigation expectation to be 75%. The data analysis focused on the evaluation of subgroups of nodes to determine if respondents followed the same or different navigation strategies for nodes that existed within areas, schematic lines, and columns, and whether the

navigation strategies used could be explained via a rule set. For each question, a data set of applicable node transitions (extracted from the overall data set) was identified and scrutinized to look for consistency in cursor navigation expectations.

Assumptions and Limitations. There were several assumptions and limitations to Study 2. This study assumed that the 4-way baseline results of the previous study could be used to derive a baseline set of expectations for the new 2-way CCD. With the addition of context elements, this study did not create equivalent trials *with* and *without* context features. Again, the Study 1 results were taken as the context-free, baseline expectations. The concern was that this study would become prohibitively lengthy if baseline context-free trials were included. Thus, the baseline threshold of 75% agreement between user responses from Study 1 to define a rule was used in Study 2. Finally, this study used Orion displays as the basis for two of the four trials. This resulted in confounding of controllable elements that were themselves part of combinations of multiple context elements (areas, schematic lines, and columns). However, basing two of the trials on these Orion displays outweighed the concern of exhaustively testing every possible element in isolation.

Results

Effect of Common Boundary. When a set of nodes was within a common boundary, the rightmost and leftmost nodes in each row were defined as edge nodes for that boundary. In an *internal wrap transition*, the participant was essentially treating the bounded area as its own display and thus navigated between rows within that area. Two possibilities are illustrated in Figure 10; normally, a right transition from node A takes the cursor to node B. However, the addition of a boundary between those nodes may result in an internal wrap between node A and node C.



Figure 10. Possible effect of area boundary on cursor navigation. Diagram (a) is a right transition without any context features. Diagram (b) is a right transition with an area context feature.

A subset of the data (496 nodes) qualified as potential internal edge nodes within an area. Results on this data set indicated that participants chose the internal wrap across all trials 80.6% of the time when a boundary was present (see Table 2). Four trials were conducted, each with a different set of nodes. The first two trials (A, B) were based on Orion displays; the remaining trials (C, D) were constructed to create situations of interest. Trial A (83.3%) and Trial B (92%) showed a strong preference for internal wraps. However, Trial C (60.5%) and Trial D (72.5%) showed a weaker preference.

Table 2. Results of the boundary area investigation.

TRANSITION	Trial A	Trial B	Trial C	Trial D	TOTAL
Internal Wrap	155 (83.3%)	126 (92%)	26 (60.5%)	93 (71.5%)	400 (80.6%)
Row-dominant	8 (4.3%)	9 (6.6%)	10 (23.3%)	16 (12.3%)	43 (8.6%)
Other	23 (12.4%)	2 (1.5%)	7 (16.3%)	21 (16.2%)	53 (10.8%)

Analysis at each individual node suggests that several boundary effects are confounded for some of these nodes. For example, it could be that there was a “column effect” for a left transition at an area left edge node, as four participants navigated to the northeast (i.e., up and the *right*, which would be an internal wrap) instead of straight north (which would be a column effect). It is this type of effect that may be behind the “other” category transition (10.8% of all trials, as seen in Table 2). In general, the “other” category was for transitions not explained by either internal wraps or row-dominant behavior. A focused analysis on the effect of column node

arrangements on navigation decisions is described to help investigate this possibility further. When there are no confounding effects, the area boundary creates a strong preference for an internal wrap.

Effect of Connectedness. When two nodes are connected by a line, it may affect where users expect the cursor to jump. Two possibilities are illustrated in Figure 11; normally, a right transition from node A takes the cursor to node B (Figure 11a). However, in the presence of lines (Figure 11b), a right transition from node A may “follow the line” and jump to node C.

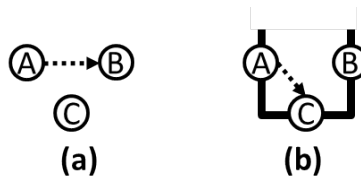

Figure 11. Possible effect of line connections between nodes. Diagram (a) is a right transition without any context features. Diagram (b) is a right transition with an line context feature.

To answer the question of whether line-connected node transitions were different from baseline expectations, a data set was constructed to include only those data where the participants following the row-dominant strategy chose a different node than if they were “following the line” between nodes. Thus, the strategy (following the line vs. row dominant) was obvious by which destination node was chosen. Over the trials (note that Trial B had no line-connected nodes), there was a total data set of 122 transitions. The results are summarized in Table 3.

Table 3. Results of connector line investigation.

TRANSITION	Trial A	Trial C	Trial D	TOTAL
Follow Line	14/54 (25.9%)	13/41 (31.7%)	10/27 (37%)	37/122 (30.3%)
Follow Row-dominant	38/54 (70.4%)	12/41 (29.3%)	7/27 (25.9%)	57/122 (46.7%)
Follow Other	2/54 (3.7%)	16/41 (39.0%)	10/27 (37.0%)	28/122 (23.0%)

Only 30.3% of transitions “followed the line” rather than followed the row-dominant strategy (46.7%) or a different strategy (23.0%). Thus, not quite a third of participants changed their behavior from the baseline strategy to a “follow the line” strategy. While not explicitly tested, the thickness of the line did not seem to influence behavior. Though not entirely conclusive, line connections between nodes appear to have only a weak effect on user cursor navigation expectations.

Effect of Proximity (Column Node Arrangements). In situations where a set of nodes formed a natural column, data were analyzed to determine whether participants “followed the column” or followed the row-dominant “cross the column” rule set. Two possibilities are illustrated in Figure 12; normally, a right transition from node B takes the cursor to node C (Figure 12a). However, in the presence of a column arrangement of nodes (Figure 12b), a right transition from node B may “follow the column” and jump to node E.

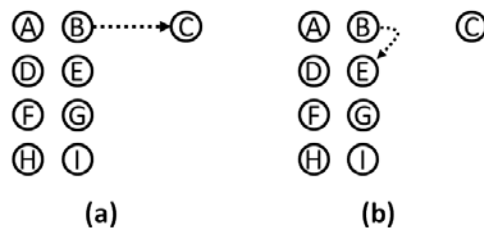

Figure 12. Possible effect of a column node arrangement between nodes. Diagram (a) is a right transition without any context features. Diagram (b) is a right transition with column node arrangement.

As in the previous analysis, the data set consisted of nodes where the strategy (i.e., row or column dominant) resulted in a different target node being chosen. Areas that contained one column of nodes were not included in the analysis, as they were edge nodes.

Analysis of transitions revealed that 68.4% of the time, participants chose to move along the column i.e., up or down instead of following the row-dominant philosophy or “other”, (chosen 31.5% of the time by participants, see Table 4). Transitions identified as “other”

represented stepwise-type navigations, where participants chose to move along the columns by jumping back and forth between columns.

Table 4. Results of column node investigation.

TRANSITION	Trial B	Trial C	Trial D	TOTAL
Column Movement (Up or Down)	62 (68.9%)	44 (83%)	22 (50%)	128 (68.4%)
Row-dominant Expectation or Other	28 (31.1%)	9 (17%)	22 (50%)	59 (31.5%)

While not as strong as the row-dominant philosophy, columns of nodes appeared to “pull” movements down to the right and up to the left. Furthermore, when nodes were very close together vertically, there was an increased chance that participants chose to transition along the column; however, when nodes become more spread out vertically, participants tended to choose to move in a row-dominant strategy. Thus, it appears that for column node arrangements, users can be expected to transition up and down through the column when the column is well-defined and closely spaced.

Discussion

The row-dominant rule set suggested that *without* the presence of common boundaries, schematic lines (connectedness), and columns, participants typically navigated across the entire GUI along a series of nodes as if they existed in a perceived row or grid arrangement. The results of Study 2 indicated that the presence of bounding boxes that created distinct areas of nodes on GUIs changed user cursor navigation expectations. Within an area boundary, participants followed the *row-dominant* rule set but wrapped to nodes within the boundary rather than exiting the area. The effect of schematic lines between nodes was found to be weak, as users tended to maintain stronger expectations of row-dominant cursor navigation. Finally, the presence of distinct columns within an area did affect expectations; users used the LEFT and RIGHT inputs to navigate up or down the column efficiently.

Anecdotally, participants reported that their movement heuristics stayed the same for all trials, but did change in response to some context features. For example, one participant reported, “Areas of nodes highly influenced my movements. Even where explicit boundaries did not exist I expected the cursor to behave as if there were implicit sub-groups or blocks of nodes.” This was the prevailing opinion of participants who commented on the effect of areas and columns of nodes. However, when asked if they would follow schematic lines or follow their regular movement pattern, all but three participants ignored the lines. Perhaps the act of navigation is faster when focusing on the placement of nodes, rather than trying to follow the flow of interconnected lines on a system diagram. Of the remaining three participants, two moved along the lines, and the third reported being influenced by “the predominant orientation of the other nodes.”

Because the areas, lines, and columns of nodes in the current study were rarely presented in isolation, there was likely a confounding effect that did not allow the results to be as clear-cut as those in the first study; hence, it is more difficult to reduce these results into a simple rule set. However, there are some rules that can be applied by display designers to help support most users’ expectations of how to navigate the cursor using a two-way input (e.g., rocker switch). While displays will be laid out first and foremost because of function and system considerations, when display designers have choices about layout, it would be useful to consider some design guidelines:

- If it is desirable for users to remain within a series of nodes particular to a function, then present those nodes surrounded by a visual boundary, as participants will tend to expect to wrap internally within the boundary area.

- Do not change cursor movement rules because of lines connecting nodes. When transitioning between nodes located on a schematic line, users expect to navigate from node to node with the “normal” strategy, and not necessarily along the line if that movement would be in a different direction.
- Avoid complex node arrangements that are visually connected in different ways within the same visual boundary. For example, avoid placing nodes that are located along a schematic line within an area, when the boundary also contains a column arrangement of nodes that are not along a schematic line.
- If it is important to maintain cursor navigation along nodes within a column, then try to make the column visually distinct from other nodes. For example, when there are multiple columns of nodes or when column nodes exist near other non-column nodes, keep the columns as far apart horizontally as possible and/or keep the column nodes as far away from the non-column nodes as possible. Also, keep nodes within a column in close proximity to one another.

CONCLUSIONS

GUIs that respond in a way that match a user’s expectations will be deemed more usable and intuitive. The two studies described in this paper established that perceptual grouping effects influence a user’s expectations of cursor movements to varying degrees. Cursor movement expectations were dependent upon the strength of the various grouping effects, and particularly those of grouping by proximity and grouping by common region.

Based on these results, a simple rule set was developed to govern how a cursor should move through a set of nodes on an Orion GUI, no matter how the nodes are arranged. The simple

rule set also supports users in building a straightforward mental model that closely matches their natural expectations for cursor movement.

While format designers could have dictated a rule set and forgone the analysis described in this paper, it was important to investigate and identify a cursor control methodology that is as intuitive as possible for users because the Orion vehicle will experience wide extremes of operational environments (i.e., from slow-paced, zero-gravity operations to high-G, high-vibration, time-critical operations). The perceptual grouping Gestalt principles of proximity and past experience were the principal drivers of cursor expectations. Location and distance (i.e., proximity in a particular direction) drove direct cursor transition expectations. Past experience with cursor devices, and in particular, line-feed typewriters, command line displays, and the performance of general word processing tasks, most likely governed the wrap transition expectations.

While the rule set of the initial study was attractive in its simplicity, there were tradeoffs in the experimental design in that it removed all context features in order to understand the baseline user cursor expectations. A second study was conducted to understand if there was any modulating effect by the three principal context features found in Orion displays: area boundaries, schematic lines, and column node arrangements. The data did show some effects, principally for area boundaries and a somewhat weaker preference to navigate up and down columns. Perceptual grouping principles of common region (i.e., nodes in an enclosed area) and proximity (i.e., rows or columns distinct from other nodes) had a strong effect on user cursor expectations, while the principle of element connectedness (i.e., schematic lines between nodes) had a weak effect. When several principles competed, the grouping results were less clear-cut. However, the results did help to identify a set of cursor navigation design guidelines that will

help format designers take advantage of natural context-driven user cursor movement expectations.

Potential applications of this research include any display format design where users are restricted to a limited degree-of-freedom CCD, or where cursor navigation is restricted to discrete jumps between displayed controllable elements. These restrictions often occur in environments where vibration and/or acceleration are significant, including in spacecraft, aircraft, and automobiles. This research also demonstrates that users have inherent expectations of how a cursor should transition among various elements, and these expectations are surprisingly consistent. Results from these studies can be used by GUI designers to anticipate users' cursor movement expectations and apply them accordingly to improve the usability of GUI designs.

ACKNOWLEDGMENTS

This paper was supported by a contract with Lockheed Martin (RH6-118204), for which Cleon Lacefield serves as the Program Manager of the Orion program. The opinions expressed herein are those of the authors and do not necessarily reflect the views of Lockheed Martin or NASA. The authors would like to thank Paul Campbell, Lisa Fairey, Robert De Mers, Leslie Potter, and Max Morris for feedback on drafts of the manuscript.

KEY POINTS

- Due to extreme gravitational and vibration loads during dynamic phases of flight, Orion GUI designs used a “caged” cursor to “jump” from one controllable element (node) to another. However, nodes were not likely to be laid out on a rectilinear grid, and so movements between nodes were not obvious.
- This paper described two studies conducted to develop an understanding of factors that drive user expectations when navigating between discrete elements on a display via a limited degree-of-freedom cursor control device (CCD).
- Gestalt principles of perceptual grouping could be used to explain cursor movement expectations. It was hypothesized that the distance between nodes, the direction of the nodes from each other, and context features all contribute to user cursor movement expectations when using the CCD.
- Our goal was to provide Orion display designers a simple set of cursor movement rules consistent with user expectations, thereby reducing navigation errors, increasing usability, and decreasing task completion time.

REFERENCES

- Adelstein, B.D., Beutter, B.R., Kaiser, M.K., McCann, R.S., Stone, L.S., Anderson, M.R., Renema, F., & Paloski, W.H. (2008). Influence of Combined Whole-Body Vibration Plus G-Loading on Visual Performance. *NASA Human Research Program*. Available online at:
http://humansystems.arc.nasa.gov/groups/isis/publications/Readability_Vibration_Report_20081113.pdf.
- Boyer, J., Hamblin, C.J., & Holden, T. (2008). Orion Cursor Control Device Glove Box Evaluation. Unpublished NASA report.
- Boyer, J., Hamblin, C.J., & Holden, T. (2009). Usability and Workload Evaluation: A Rocker Switch and a Four-way Castle Switch. Unpublished NASA report.
- Dorneich, M.C., Lancaster, J., Hamblin, C.J., DeMers, R.E., and Olofinboba, O.A., (2010). Deriving Cursor Control Device Expectations for the Orion Crew Exploration Vehicle. *Proceedings of the Human Factors and Ergonomics Society's 54th Conference*, San Francisco, CA, September 27 – October 1.
- Ellis, W. (1938). *A source book of Gestalt psychology* (pp. 71-88). London: Routledge & Kegan Paul.
- Fitts, P.M. (1954). The information capacity of the human motor system in controlling amplitude of movement. *Journal of Experimental Psychology*, 47, 381-391.
- Fitts, P.M., & Peterson, J.R. (1964). Information capacity of discrete motor responses. *Journal of Experimental Psychology*, 67, 103-112.
- Hamblin, C.J., Boyer, J., & Holden, T. (2008). Orion Cursor Control Device Functional Evaluation. Unpublished NASA report.
- Iqbal, Q., & Aggarwal, J. K. (2001). Perceptual Grouping for Image Retrieval and Classification, *Third IEEE Computer Society Workshop on Perceptual Organization in Computer Vision (POCV 01)*, Vancouver, BC, Canada, July 8.
- Koffka, K. 1935. Principles of Gestalt Psychology. *Psychological Bulletin*, 19. 531-585.
- Kubovy, M., & Wagemans, J. (1995). Grouping by proximity and multistability in dot lattices: A quantitative Gestalt theory. *Psychological Science*, 6 (4), 225-234.
- NASA (2008). *NASA-Orion Crew Exploration Vehicle*. Available from NASA Web site:
http://www.nasa.gov/mission_pages/constellation/orion/.

- Palmer, S.E. (1992). Perceptual Grouping: It's later than you think. *Current Directions in Psychological Science*, 11, 3, 101-106.
- Palmer, S. & Rock, I. (1994). Rethinking perceptual organization: The role of uniform connectedness. *Psychonomic Bulletin and Review*, 1, 29-55.
- Schmidt, C.F. (2001). Wertheimer on organizing principles of perceptual grouping: On Perceptual Grouping. Available online at: http://www.rci.rutgers.edu/~cfs/305_html/Gestalt/wertheimer2.html.
- Thompson, S.G., McConnell, D.S., Slocum J.S., and Bohan, M. (2006). Kinematic Analysis of Multiple Constraints on a Pointing Task. *Human Movement Science*, 26, 11-26.
- Todorvic, D. (2008). Gestalt Principles, *Scholarpedia*, 3(12):5345.
- Tuceryan, M. & Jain, A. K. (1998). Texture Analysis, In *The Handbook of Pattern Recognition and Computer Vision*, C. H. Chen, L. F. Pau, P. S. P. Wang (editors.), World Scientific Publishing Co., pp. 207-248.
- Wertheimer, M. (1923). Untersuchen zur Lehre von der Gestalt II. *Psychologische Forschung*, 4, 301-304.

BIOGRAPHIES

Michael C. Dorneich was a Principal Research Scientist in the Human Centered Systems Group at Honeywell Laboratories and is now an Associate Professor in the Industrial and Manufacturing Systems Department at Iowa State University. He earned his Ph.D. in Industrial Engineering in the Human Factors Program at the University of Illinois at Urbana-Champaign in 1999.

Christopher J. Hamblin is a Senior Research Scientist in the Human Centered Systems Group at Honeywell Laboratories. He earned his Ph.D. in Human Factors Psychology from Wichita State University in 2005.

Jeff A. Lancaster is a Research Scientist in the Human Centered Systems Group at Honeywell Aerospace. He earned his Ph.D. in Industrial & Systems Engineering-Human Factors from Virginia Tech in 2004.

Olu Olofinboba is the Technology Portfolio Manager for Crew Interface at Honeywell Laboratories. He earned his M.S. in Computer Engineering at the University of Southern California in 1993 and MBA from the University of Minnesota in 2012.