

A NEW ECT PROBE WITH ROTATING DIRECTION EDDY CURRENT

H. Hoshikawa and K. Koyama
College of Industrial Technology
Nihon University
Izumicho Narashino Chiba 275, Japan

INTRODUCTION

In the eddy current testing, various kinds of noise are generated by variations of many factors such as the probe lift-off and the material configuration. A lot of efforts have been made to develop new probes with little noise[1,2]. The authors think that it is necessary to develop a new noise free ECT probe in order to conduct the quantitative nondestructive testing.

The authors have devised a new ECT probe called the Hoshi Probe which utilizes uniform direction rotating eddy current. The probe features are 1)self-differential, 2)lift-off noise free, 3)self-nulling, and 4)different signal generating, depending on the direction and the position of the flaw to the pick-up coil. The probe will conduct eddy current nondestructive testing with minimal noise and will generate high levels of data on flaws.

STRUCTURE OF THE HOSHI PROBE

As shown in Figure 1, the Hoshi Probe comprises of a pair of rectangular exciting coils and a pancake pick-up coil. These two exciting coils are wound orthogonally carrying electric currents of 90 degrees out of phase. The exciting coils produce a uniform direction rotating magnetic field within the conducting material under the probe. Thus the direction of the eddy current induced within the material, rotates synchronizing to the cycle of the exciting coil currents.

The pick-up coil detects the local variations of the uniform rotating eddy current under the probe. If the flaws, such as cracks, are only in one direction, the pick-up coil can be rectangular or rhombic.

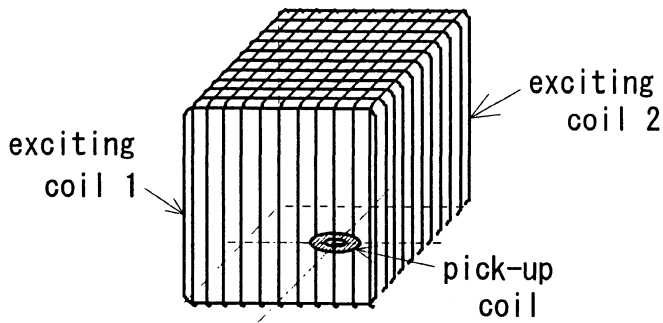

Figure 1. Structure of the Hoshi Probe.

PERFORMANCE AND FEATURES OF THE HOSHI PROBE

Every small arc of the circular pick-up coil winding detects only the local eddy current component parallel to the arc. When the eddy currents running under two small arcs of the pick-up coil winding opposite the circular coil center, are identical, the induced voltages at the arcs cancel out each other. This is because the eddy currents flow in the same direction and the voltages along the coil winding are induced in the opposite direction. Thus a pair of small arcs across the pick-up coil center detect only the difference between the eddy currents induced under them. Consequently, the Hoshi Probe has a self-differential nature which eliminates the influences from single-dimensionally uniform variations of electromagnetic characteristics and configurations in the test material. The authors consider that the self-differential nature can make the Hoshi Probe applicable to the inspection of tubing with support plates and welded parts in metal products.

Each pick-up coil arc detects flaws which cause the local variations of the eddy current component parallel to it. Since the coil configuration is circular and the eddy current direction rotates under the probe, the probe detects all flaws of every direction while the probe scans precisely over the flaws.

The self-differential feature also makes the Hoshi Probe free from lift-off noise because the probe lift-off happens single dimensionally uniform to the pick-up coil. Thus the Hoshi Probe is very low noise ECT probe.

Furthermore the self-differential feature gives the Hoshi Probe self-nulling characteristics, which eliminate the bridge circuit and its balance procedures. Thus the self-differential makes eddy current testing with the Hoshi Probe easier and quicker.

Each small pick-up coil arc detects only the component of eddy current variation parallel to its direction. The arc is sensitive to flaws perpendicular to it and not flaws in the same direction. Consequently, if the probe scans precisely over a flaw and displays the signal three

dimensionally, the line connecting the maximum signal position indicates the direction of the flaw.

The phase of the pick-up coil voltage depends on the direction of the small pick-up coil arc which detects the eddy current variation in the same direction as the arc. On the other hand, the eddy current rotates synchronizing to the exciter current cycle. Therefore, the flaw signal phase is determined by the direction of a flaw and so the Hoshi Probe can also distinguish the direction of a flaw by using the flaw signal phase.

The Hoshi Probe emits a different signal phase for a front surface flaw and back surface flaw. This is because the phase of the eddy current changes according to the position from the front surface. Thus the authors consider that the Hoshi Probe provides more information on flaws than conventional ECT probes.

EXPERIMENTAL SETUP

Figure 2 shows the experimental set-up of the Hoshi Probe. The probe has a dice shaped exciter with 50 mm edges and a circular pick-up coil of 5 mm diameter or 10 mm diameter. The materials are brass plates of 160x160x1 mm³ each of which has a 0.2 or 0.5 mm wide slit-like flaw with different length and depth made by an electric discharge machine. The X-Y table moves the test material, allowing the probe to scan precisely over the flaw.

EXPERIMENTAL RESULTS

Figure 3 (a) shows flaw signal patterns obtained by scans of the Hoshi Probe when a flaw with a different direction passes along the

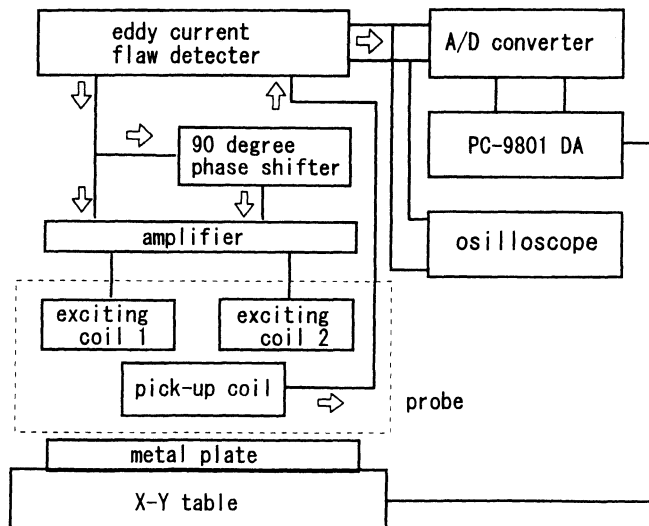

Figure 2. Experimental set-up.

scanning line ①. The flaw is a slit like one with a length of 5 mm, a width of 0.5 mm, and a depth of 0.8 mm. The flaw direction indicates the angle between the scanning direction and the flaw direction. It is seen from the figure that a flaw gives a different signal pattern depending on its direction, and a 90 degree direction flaw generates the largest signal.

Figure 3 (b) shows flaw signal patterns obtained by scans of the Hoshi Probe when a flaw with a different direction passes along the scanning line ③. The figure shows that a flaw generates a figure eight pattern and indicates that the small arc of the pick-up coil is

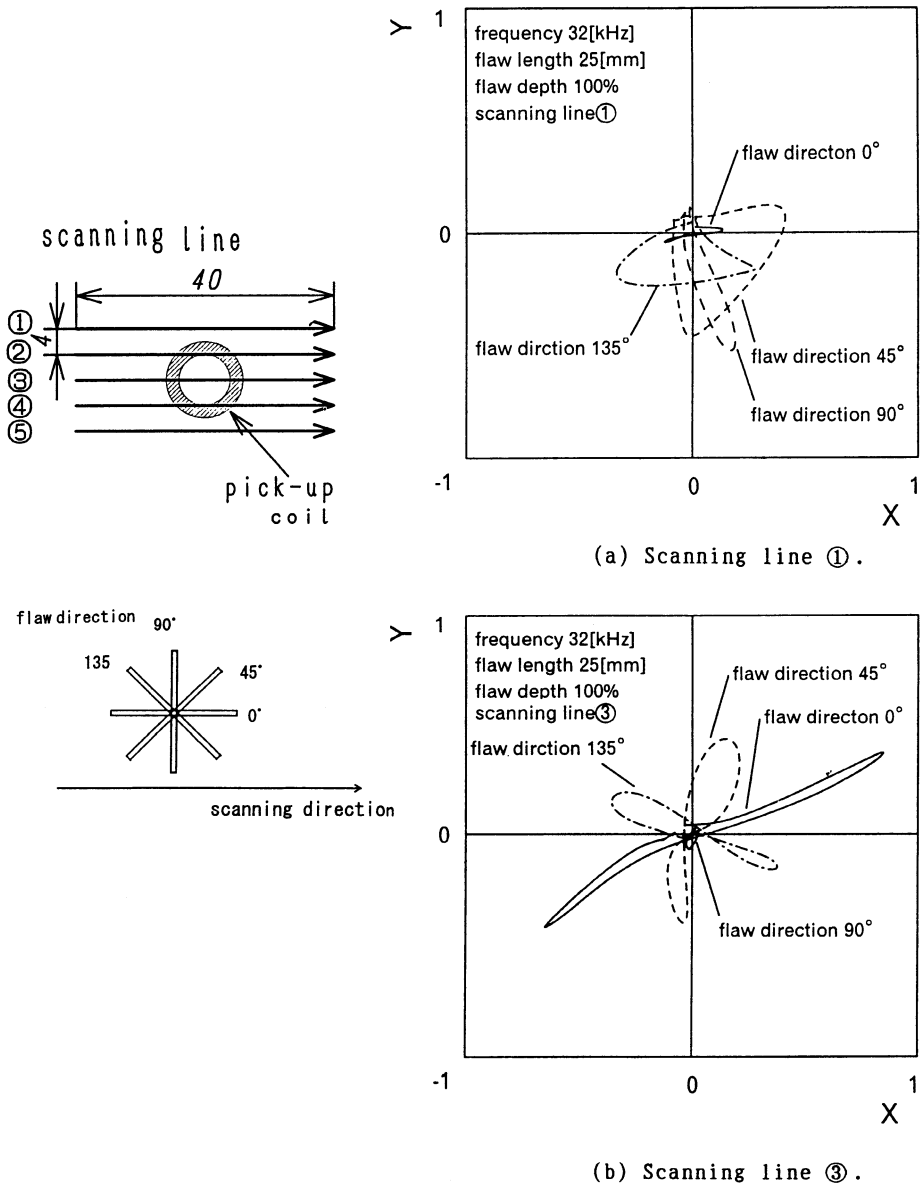
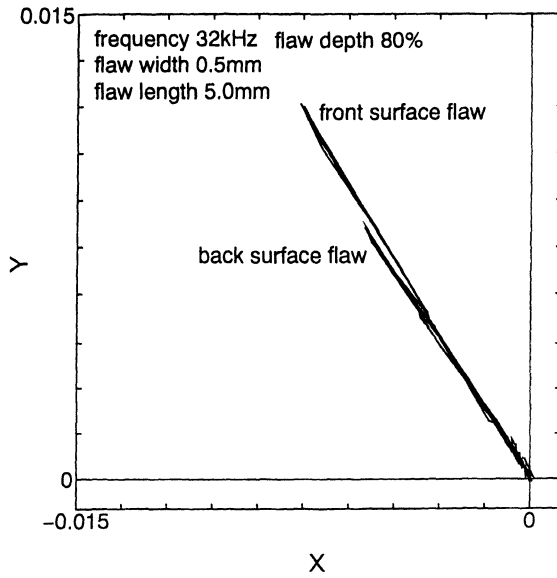
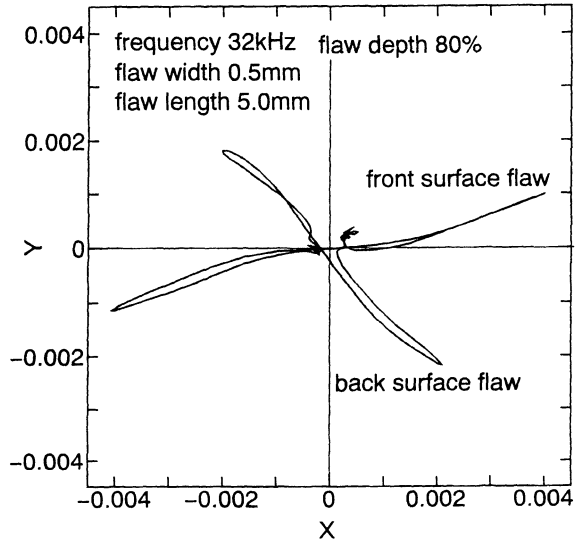

Figure 3. Flaw signal patterns.



(a) Conventional probe.



(b) the Hoshi Probe.

Figure 4. Signal patterns for a front surface flaw and for a back surface flaw.

sensitive to flaws perpendicular to the arc and not flaws parallel to the arc.

Figure 4 shows the flaw signal patterns obtained by a conventional probe and the Hoshi Probe. The conventional probe can hardly distinguish between the front surface flaw and the back surface flaw, while the Hoshi Probe provides flaw signals with different phases.

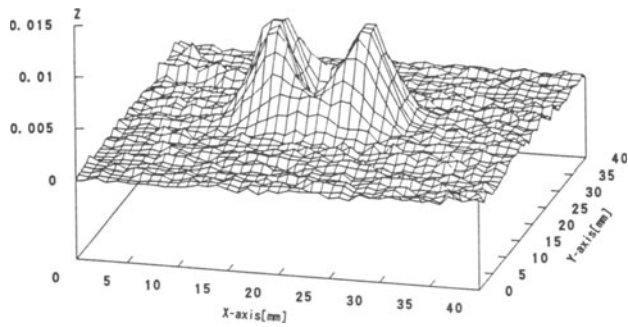

(a) without ferro-magnetic block.

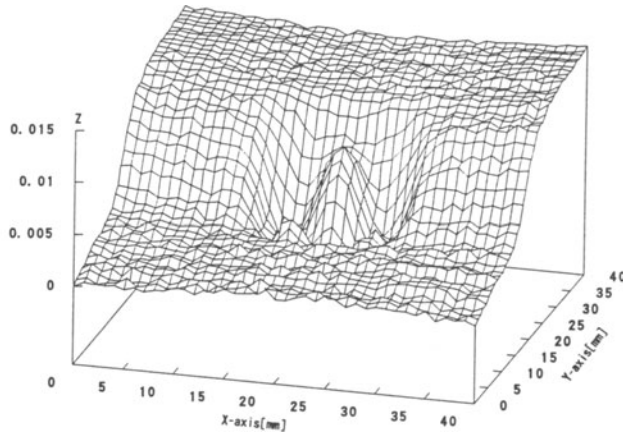

(b) with ferro-magnetic block.

Figure 5. Three dimensional display of flaw signal obtained by a conventional ECT probe.

Figure 5 shows the three dimensional display of a flaw signal obtained by the conventional pancake coil with and without a ferro-magnetic block behind the brass plate. The flaw signal is embedded in the signal from the ferro-magnetic block. Thus it is seen that the conventional probe can hardly detect flaws along the ferro-magnetic block.

Figure 6 shows the three dimensional display of flaw signal obtained by the Hoshi Probe with and without a ferro-magnetic block behind the brass plate. The figure shows that the flaw signal has little influence from the ferro-magnetic block. These results indicate that the Hoshi Probe is able to detect flaws of heat exchanger tubes under support plates.

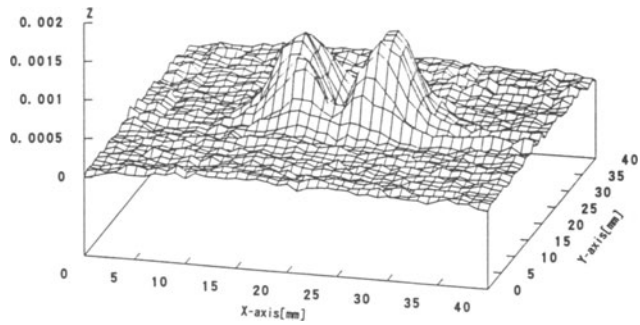

(a) without ferro-magnetic block.

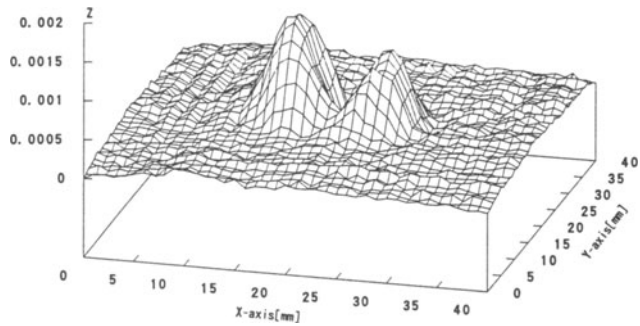

(b) with ferro-magnetic block.

Figure 6. Three dimensional display of flaw signal obtained by the Hoshi Probe.

Figure 7 shows the flaw signals and the lift-off noises. It is obvious that the Hoshi Probe generates little lift-off noise compared to the flaw signal, while the conventional probe produces quite a lot of lift-off noise. Moreover, the Hoshi Probe produces large phase differences between flaw signals and lift-off noises compared to the conventional probe. The large phase difference means it effectively suppresses the lift-off noise by phase discrimination. This results indicate that the Hoshi Probe can be a probe with minimal noise.

SUMMARY

The newly devised ECT probe using uniform rotating eddy current has been proved to be a noise-free one with high levels of data on the flaw compared to the conventional probe. The authors hope that the Hoshi Probe will be effective in some practical fields.

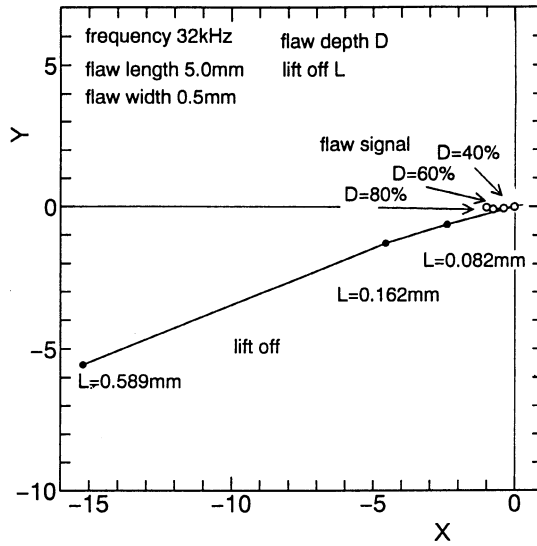

(a) Conventional probe.

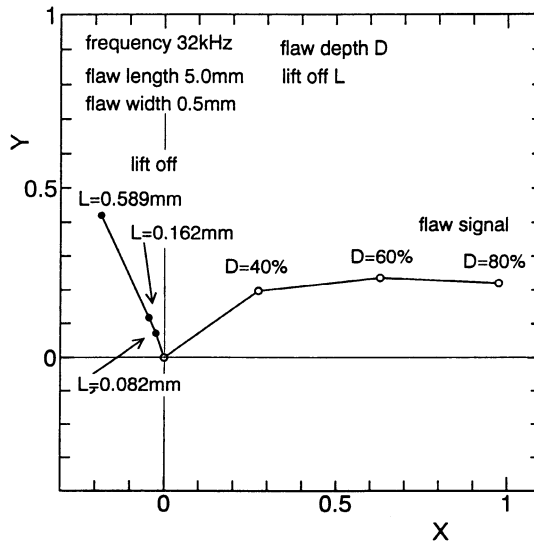

(b) the Hoshi Probe.

Figure 7. Flaw signal and lift off noise.

REFERENCES

1. Buzz Wincheski, Jim Fulton, Shrinthar Nath, and Min Namkung, "Analysis of Eddy Current Distribution and Resulting Flaw Detection Mechanism for Self-Nulling Probe", Review of Progress in QNDE, Vol.14A, p291. Plenum Press, New York, 1995
2. J. P. Fulton, B. Wincheski, S. Nath, J. Reilly and M. Namkung, "A New Electromagnetic Instrument for Thickness Gauging of Conductive materials", Review of Progress in QNDE, Vol.14A, p2317. Plenum Press, New York, 1995