

# Journal of Engineering Research

---

Volume 7

Issue 5 *This is a Special Issue from the Applied Innovative Research in Engineering Grand Challenges (AIRGEC) Conference, (AIRGEC 2023), Faculty of Engineering, Horus University, New Damietta, Egypt, 25-26 October 2023*

Article 59

---

2023

## A developed IoT technique and P&O-MPPT to enhance the output power of solar cell systems

ahmed Ali, Raafat A. El-Kammar El-Kammar, Hesham F. A. Hamed, Adel A. Elbaset, Aya Hossam

Follow this and additional works at: <https://digitalcommons.aaru.edu.jo/erjeng>

---

### Recommended Citation

Ali, Raafat A. El-Kammar El-Kammar, Hesham F. A. Hamed, Adel A. Elbaset, Aya Hossam, ahmed (2023) "A developed IoT technique and P&O-MPPT to enhance the output power of solar cell systems," *Journal of Engineering Research*: Vol. 7: Iss. 5, Article 59.

Available at: <https://digitalcommons.aaru.edu.jo/erjeng/vol7/iss5/59>

This Article is brought to you for free and open access by Arab Journals Platform. It has been accepted for inclusion in Journal of Engineering Research by an authorized editor. The journal is hosted on [Digital Commons](#), an Elsevier platform. For more information, please contact [rakan@aaru.edu.jo](mailto:rakan@aaru.edu.jo), [marah@aaru.edu.jo](mailto:marah@aaru.edu.jo), [u.murad@aaru.edu.jo](mailto:u.murad@aaru.edu.jo).



# A developed IoT technique and P&O-MPPT to enhance the output power of solar cell systems

Ahmed H. Ali<sup>1\*</sup>, Raafat A. El-Kammar<sup>2</sup>, Hesham F. A. Hamed<sup>1, 3</sup>, Adel A. Elbaset<sup>3, 4</sup>, Aya Hossam<sup>2</sup>

<sup>1</sup>Department of Telecommunications Eng., Faculty of Eng., Egyptian Russian University, Egypt – email: [ahmed-hamdy@eru.edu.eg](mailto:ahmed-hamdy@eru.edu.eg)

<sup>2</sup>Electrical Eng. Department, Faculty of Eng. (Shoubra), Benha University, Egypt – email: [rafat.alkmaar@feng.bu.edu.eg](mailto:rafat.alkmaar@feng.bu.edu.eg) and [aya.ahmed@feng.bu.edu.eg](mailto:aya.ahmed@feng.bu.edu.eg)

<sup>3</sup>Department of Electrical Eng., Faculty of Eng., Minia University, Egypt – email: [hfh66@yahoo.com](mailto:hfh66@yahoo.com)

<sup>4</sup>Department of Electromechanics Eng., Faculty of Eng., Heliopolis University, Egypt – email: [adel.soliman@hu.edu.eg](mailto:adel.soliman@hu.edu.eg)

**Abstract-** Given the urgent need for continuous development in solar cell systems to increase their efficiency, in this study, a developed IoT technique was built to monitor the solar irradiance fluctuation around the solar cell systems, and a Perturbation and observation algorithm (P&O) was developed to increase the output power from the PV systems. In order to save energy, the IoT technique has been supported with a light-dependent resistor to operate and shut down with sunlight. The whole IoT technique was fed from the PV system to save energy and avoid a power outage. The measured solar irradiance profile was displayed online on the ubidots. Then, the measured solar power irradiance through IoT was introduced to the MATLAB simulation program to study the performance of the proposed P&O maximum power point tracking (P&O-MPPT) algorithm. The P&O-MPPT algorithm was used to control the voltage and current by continuous adjustments in the duty cycle to improve the output power of the studied solar system. The obtained results showed the efficiency of the monitoring system based on IoT in recording changes in solar radiation and the improvement in the output power as a result of the developed P&O-MPPT system.

**Keywords-** PV plant, IoT technique, P&O algorithm.

## I. INTRODUCTION

Photovoltaic power plants are one of the sustainable and green energy sources whose use has increased recently [1-2]. However, the PV systems face many challenges, such as the rapid monitoring of the environmental fluctuation and the reduction in their output power [3-4]. The rapid monitoring of the surrounding environmental parameters of PV systems, such as solar irradiance, temperature, and humidity, and quickly taking appropriate measures to overcome the problems and respond to the resulting changes is the basic foundation for ensuring the effective production of electrical energy [5-6]. The Internet of Things is considered one of the very effective technologies in monitoring changes surrounding solar cell systems and the speed of transferring fluctuation in PV output data (voltage, current, and power), which has recently become popular in this field [7-8]. On the other hand, artificial intelligence algorithms such as P&O considered one of the effective means to enhance the output power of the PV-systems [9-11]. The high flexibility and performance of the P&O algorithm make it a famous AI algorithm for conducting the purpose required. It is also one of the AI algorithms that provide highly efficient solutions to improve the performance of systems in general and solar cell systems in particular [12-13]. N. Priyadarshi et al. used in 2014 a PSO artificial intelligence algorithm supported by IoT technique to reach the maximum output power. They showed that the efficiency of

the PV system enhanced significantly as a result of using PSO-IoT embedded system. In 2023, Amor Hamied et al constructed a low-cost monitoring system based on IoT for an off-grid photovoltaic (PV) system. The authors created a web page to visualize the measured data. The total cost of the built system was 73 euros and consumed 13.5 Wh daily. They concluded that their implemented system able to identify the examined defects accurately [15]. D. D. Prasanna Rani et al in 2023 proposed a cost-effective technique inclusion of IoT for remotely monitoring a solar plant performance. The authors concluded that their implemented IoT monitoring system can assist in the solar power stations real-time monitoring, diagnostics, and maintenance [16].

Hence, based on the above and with the aim of improving the efficiency of solar cells, in this study, an integrated system based on the Internet of Things and the P&O algorithm was built to monitor and improve the output power. A solar irradiance of a PV system was measured during a solar day, 7 am to 6 pm. The measured solar power irradiance was included in the MATLAB simulation to control of the output volage and current using P&O-MPPT to enhance the output power. Many adjustments in duty cycle of the P&O algorithm were carried out to reach a high maximum power output.

## II. PROBLEM STATEMENT

The monitoring systems of solar cell power stations are exposed to many difficulties and challenges, foremost of which is the delay in obtaining the surrounding circumstances of the cells, on which all procedures to be taken to repair any defect are based. The solar system output power is directly affected by the shadow, temperature, and humidity.

### A. Solar Radiation and Shadow Effect

Although the solar power radiation that is received by the solar panel approaches 1000W/m<sup>2</sup>, the unexpected shaded conditions are negatively effect on that amount, which reflects directly on the solar system performance. Under shaded conditions, the solar cells are forced to carry the current in the reverse bias, causing an appearance of negative volts, which results in an increase in the reverse current. The current multiplication I effect is estimated directly through modeling shaded PV cells by the equation [1]

$$I = I_{ph} - I_0 \left[ e^{\left( \frac{V_c + IR_s}{V_t} \right)} - 1 \right] - \frac{V_c + IR_s}{R_p} \left[ 1 + k \left( \frac{V_c + IR_s}{V_b} \right)^{-n} \right] \quad (1)$$

where,  $R_s$  and  $R_p$  are the series resistance associated with conductive losses and shunt resistance associated with distributed losses inside of the p-n material. The  $V_t$  is the thermal voltage, which calculated through  $V_t = k_B / Tq$  ( $k_B$  and  $q$  are Boltzmann's constant and the electron charge). The  $V_b$  and  $V_c$  are the breakdown and PV-cell voltage,  $I_0$  and  $I_{ph}$  are the inverse saturation current and the photo-generated current,  $k$  is the fraction of current involved in avalanche breakdown, and  $n$  is the avalanche breakdown exponent. The augmentation of the solar irradiance and the environmental temperature strongly increase the module temperature, which in turn effects on the I-V characteristics. The increase of the module temperature strongly reduces the PV-cell volage causing a reduction in fill factor and the PV efficiency. On the other hand, due the negative impact of the breakdown voltage on the output power, the reducing of the breakdown voltage reduces the dissipated power leading to an enhancement in the output power of the PV system.

The photo-generated current calculated based on the following relation

$$I_{ph} = [I_{sc\_STC} + (C_{Ti}(T_c - T_{STC}))] \frac{G_i}{G_{STC}}, \quad (2)$$

where,  $G_i$ ,  $C_{Ti}$ , and  $T_c$ , are the incident irradiance, the thermal current coefficient, and the cell temperature respectively.  $I_{sc\_STC}$ ,  $T_{STC}$ , and  $G_{STC}$  are the short-circuit current, the cell temperature, and the incident irradiance for Standard Test Conditions (25 °C and 1000 W/m<sup>2</sup>), respectively.

### B. Temperature Effect

Several parameters directly affect the solar cell temperature  $T_c$ , which are the variables of the weather [ambient temperature, local wind speed, solar radiation  $I(t)$ ], materials, and system (glassing cover-transmittance  $\tau$  and plate absorbance  $\alpha$ ). The temperature influence on the solar cell performance obtained using [18-19]

$$P_{max} = I_{max}V_{max} = (FF)I_{sc}V_{oc} \quad (3)$$

where,  $FF$ ,  $I_{sc}$ , and  $V_{oc}$  are fill factor, short circuit current, and open circuit voltage.

Due to both open circuit voltage and the fill factor decrease strongly with temperature, and short-circuit current increases slightly, the net effect leads to a following linear relation between solar cell temperature  $T_c$  and its efficiency [18-19]

$$\eta_c = \eta_{Tref} [1 - \beta_{ref}(T_c - T_{ref}) + \gamma \log_{10} I(t)] \quad (4)$$

where,  $\eta_{Tref}$  is the PV module efficiency at the reference temperature  $T_{ref}$  (at solar power 1000W/m<sup>2</sup>),  $\beta_{ref} = 0.004 \text{ K}^{-1}$  is the temperature coefficient, and  $\gamma = 0.12$  is the solar irradiance coefficients. The value  $\gamma \log I(t)$  take as zero, hence equation 4 reduce to be

$$\eta_c = \eta_{Tref} [1 - \beta_{ref}(T_c - T_{ref})] \quad (5)$$

### C. Humidity Effect

Humidity, which refers to the accumulation of tiny water droplets on the solar panels' surfaces side by side with the water evaporation, is one of the most critical factors that directly affects the output of solar cells and requires regular cleaning. The layer of water droplets on the solar panels reflects, refracts, and deflects the solar irradiance, reducing the intensity of the radiation reaching the solar cell. On the other hand, continuous exposure to moisture causes corrosion in solar cell panels, and the possibility of this corrosion increases with the increase in temperature on the surfaces of the cells [20-21]. The impact of moisture on the solar cell efficiency depends on the area of the solar collector ( $A_c$ ), average incident solar radiation ( $I_s$ ), total amount of water to be removed ( $M_w$ ), latent heat of vaporization of water ( $L_h$ ), power consumed by the fan ( $P_f$ ), and power requirement of mobile alert system ( $P_m$ ) according to the equation 6 [22].

$$(\%) \eta = \frac{M_w \times L_h}{(I_s \times A_c) + P_f + P_m} \times 100 \quad (6)$$

### III. METHODOLOGY OF THE PROPOSED SYSTEM

Embedded system of smart monitoring IoT system and P&O-MPPT artificial intelligence algorithm were designed and constructed, as shown in Fig. 1. The constructed integrated system consisted of a LDR starter, relay, solar irradiance, Node MCU ESP8266 (ESP-12E), PV array, DC-DC converter, and P&O-MPPT.

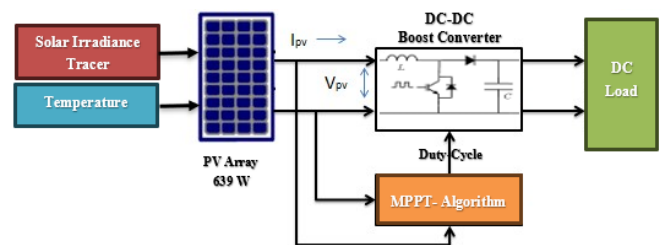

Figure 1. The block diagram of the proposed IoT and P&O system.

#### A. IoT System

The main description of the block diagram of the smart IoT system, the feeding system, and the flow chart are shown in Fig. 2. An integrated system of the radiation sensor LDR was connected to the Node MCU ESP8266 (ESP-12E) kit was built and fed through a PV to save energy and protect from outages. The Node MCU ESP8266 was programmed to sense the solar irradiance (lux) and convert it to the solar power irradiance (W/m<sup>2</sup>) according to the illustrated conde in Fig. 3.

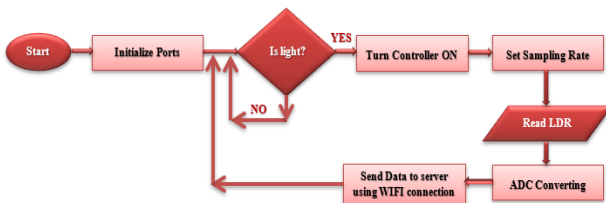
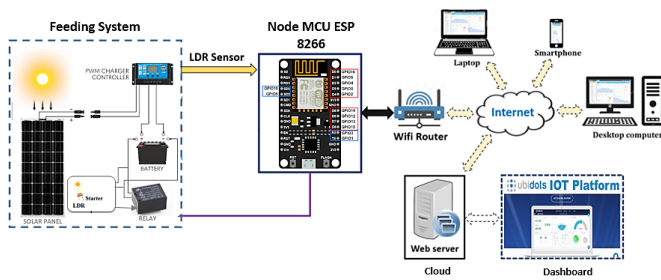

Fig. 2. The proposed IoT block diagram and flow chart.

```

#include "Ubidots.h"
#include <DHT.h>
float hum = 0.0, temp_c = 0.0;
const byte DHT_PIN = D1;
const byte DHT_TYPE = 11;
DHT dht(DHT_PIN, DHT_TYPE);
int LDR = 0;

const char* UBIDOTS_TOKEN = "BBFF-ixrMcLhLVBCFmRnNCPggrOYqARQKFD";
const char* WIFI_SSID = "ARE";
const char* WIFI_PASS = "0102795252Ar#";
Ubidots ubidots(UBIDOTS_TOKEN, UBI_HTTP);

void setup() {
  dht.begin();
  Serial.begin(115200);
  pinMode(LDR, INPUT);
  ubidots.wifiConnect(WIFI_SSID, WIFI_PASS);
  ubidots.setDebug(true);
}

void loop() {
  delay(5000);
  double hum = dht.readHumidity();
  double temp_c = dht.readTemperature();
  if (isnan(hum) || isnan(temp_c)) {
    Serial.println("Failed to read from DHT sensor!");
    return;
  }

  double vout1 = analogRead(A0);
  float vout = vout1/204.6;
  float R = (11000-vout*2200)/vout;
  float lux = (pow(R, (1/-0.8616)))/(pow(10, (5.118/-0.8616)));
  float solarpower = (lux/683)*345.396656;

  ubidots.add("Humidity", hum);
  ubidots.add("Temperature", temp_c);
  ubidots.add("Irradiance", lux);
  ubidots.add("Power radiation", solarpower);
  bool bufferSent = false;
  bufferSent = ubidots.send();
  if (bufferSent) {
    Serial.println("Values sent by the device");
  }
}
    
```

Figure 3. The programming code of the considered system.

The Node MCU ESP8266 (ESP-12E) kit has been connected to router by TCP/IP protocol stacks, which gives the microcontroller access to the WiFi network. Finally, using HTTP protocol, an account was conducted on the ubidots to accelerate the data receiving and displaying online on a live profile.

The constructed hardware of the IoT prototype is shown in Fig. 4. A solar panel, charger controller, PV battery, LM7805CT regulator, smart operating system, Node MCU ESP8266 (ESP-12E), and LDR sensor. In the smart operating system, the LDR starter was connected to the 5V relay driven by the BC547BP

transistor. The smart operating system automatically controls the feeding power of the monitoring system depending on the solar LDR starter through the relay. The PV-battery output is linked to the regulator, which in turn is linked to the smart operating system and the Node MCU ESP8266 (ESP-12E). The radiation sensor directly feeds from the Node MCU, while the router feeds directly from the PV system to avoid the loss of transferred data due to power outages.

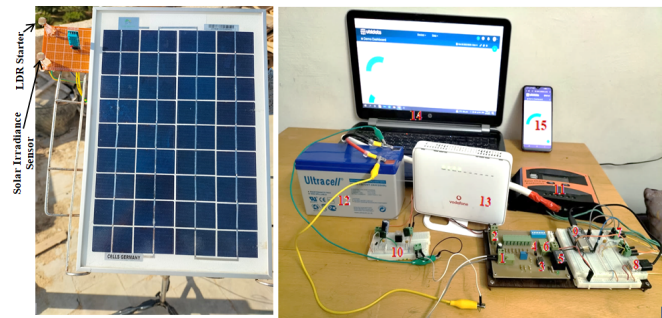

Figure 4. The implemented IoT prototype a) The installed PV panel, LDR starter, and solar irradiance sensor and b) The practical control system, 1) LDR starter jumper, 2) 5V from regulator, 3) Operational amplifier, 4) Transistor BC547BP, 5) 5V Relay, 6) 5V to Node MCU, 7) 2 jumpers from solar radiation sensor to 3.3V of Node MCU and analog pins A0, 8) Usb cable, 9) Node MCU ESP8266, 10) Regulator LM7805CT and diode 1N4007, 11) Solar charger controller (12V, 10A), 12) Rechargeable PV battery (12V, 7.2A), 13) Router, 14) Laptop, 15) Mobile phone.

### B. Artificial Intelligence Simulation

To enhance the output power of PV systems through controlling the duty cycle of P&O, a PV-array linked to DC-DC boost converter was built on MATLAB/ Simulink, as illustrated in Fig. 5. The PV array and DC-DC boost converter parameters are tabulated in Table 1. The constructed PV system was supplied by the measured solar power irradiance data, which were measured using the smart IoT technique. The output PV voltage and current are sensed by the P&O-MPPT algorithm. The P&O-MPPT controller algorithm modify the duty ratio and generating a PWM, which in turn transfer to the switch of the DC-DC boost converter. The proposed MATLAB/Simulink PV array model was built through three series PV modules in one string. The PV array for the studied system and fed by variable solar power irradiance at 25 °C as shown in Fig. 5.

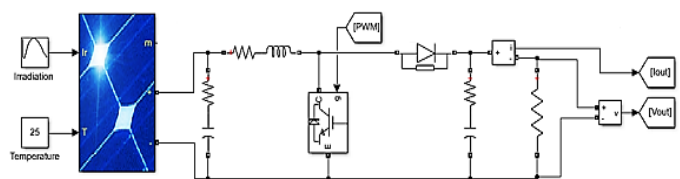

Figure 5. The PV source linked with DC-DC boost converter.





Table I. The PV array and DC-DC converter characteristics.

PV-array		DC-DC converter	
Parallel strings	1	Inductor	10mH
Series-connected modules per string	3	Capacitor	500µF
Module	1Soltech 1STH-215-P	Switching frequency	50kHz
Maximum Power (W)/ module	213.15		

By properly adjusting the duty cycle, the maximum power output can be achieved. Here, P&O-MPPT algorithm was used to control the duty adjustment. Generally, the P&O-MPPT controller based on the voltage pulses perturbation, growth and reduction, around its initial value. The perturbation is the main factor affecting the duty cycle of PWM, which controls the DC-DC converter output [22]. The MPP is obtained through P&O by realizing the following condition

$$\Delta P_{pv} \Delta V_{pv} = 0 \quad (7)$$

Hence, to improve the P&O output voltage, a changing in duty cycle D was carried out to tune the variable value of the perturbation through the factor  $\Delta D$  as shown in Fig. 6. The fluctuation of the output value around MPP was controlled and minimized using reducing the step size. Step size makes a large change in the duty cycle if the operating point is far from MPP and reduces the change when the operating point is close to MPP.

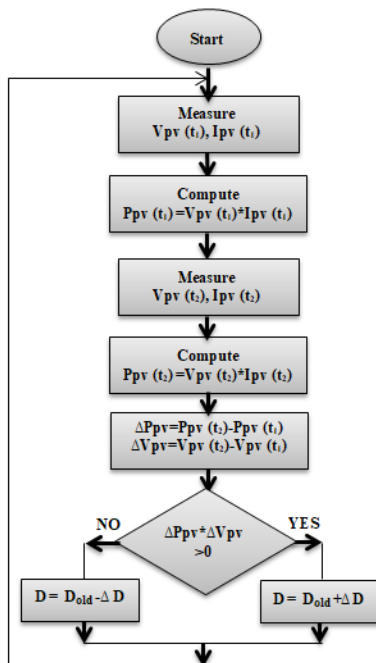

Figure 6. The improved P&O flowchart.

The Simulink block diagram model of the P&O-MPPT algorithm is shown in Fig. 7.

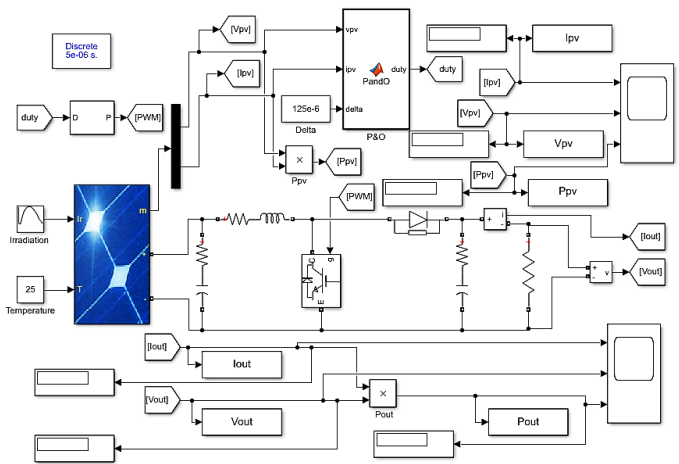

Figure 7. The block diagram of P&O MPPT controller.

#### IV. RESULTS AND DISCUSSION

Fig. 8 shows the measured solar profile of the building smart IoT system. The profile is displayed online live, moment by moment, through ubidots platform in several different graphical forms, as shown in Fig. 8. The ubidots platform is accessed directly through any device connected to the Internet, such as a mobile phone or laptop.

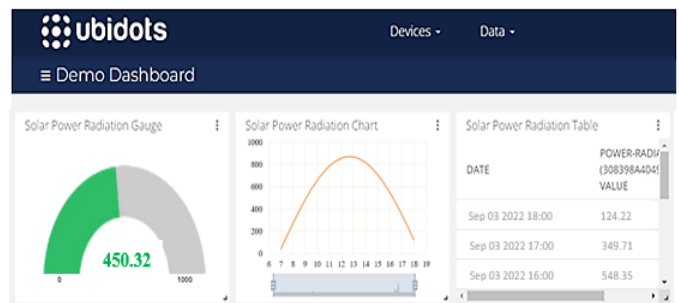

Figure 8. The ubidots live visualization of the measured solar power irradiance using the proposed IoT system.

The obtained simulation results of current, voltage, and maximum generated power waveforms of the conventional P&O and improved P&O under different solar irradiance conditions are shown in Fig. 9. First, it was found that both the current and voltage are dramatically influenced by irradiance changes. It was observed from Fig. 9, the output voltage of the improved P&O is the highest due to the permanent control in the duty allowing tracking of the maximum power output. Consequently, the output power of the system based on the improved P&O outperforms that the conventional P&O for each value of solar irradiance.

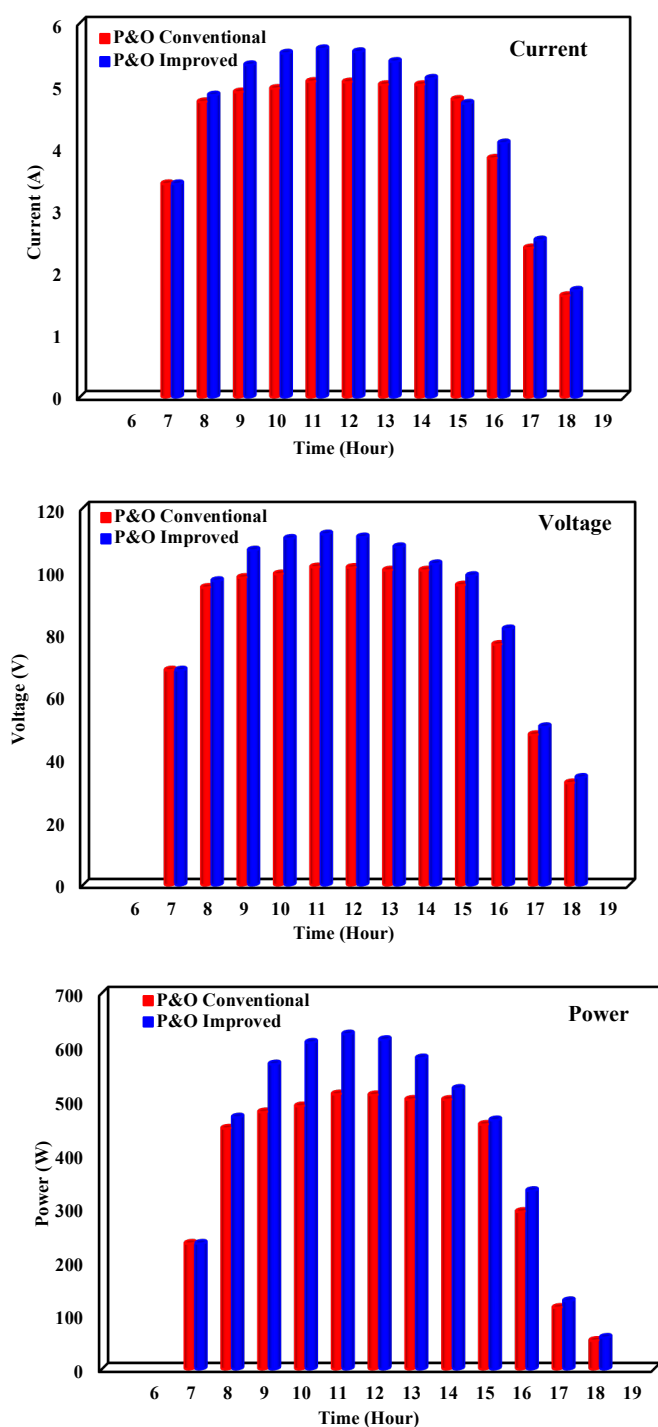

Figure 9. The output current, voltage, and maximum output power of the conventional and improved P&O.

#### V. CONCLUSION

A smart IoT technique depending on an integrated system of Node MCU ESP8266 (ESP-12E) was implemented to monitor the PV systems and the receive the solar power irradiance data quickly. On the other hand, a P&O-MPPT artificial intelligence algorithm was used to control the output voltage and current to enhance the output power of PV systems. The implemented IoT technique monitor, transfer, and lively

Doi: 10.21608/erjeng.2023.243128.1282

display the solar power irradiance data successfully. The improved P&O-MPPT has a faster-reaching speed to MPP than conventional one. Hence, the produced smart IoT prototype can be used in the continuous monitoring of PV systems aiming to rapidly intervene to solve any encountering operating problems, which is positively affect the improving of the PV systems performance. On the other hand, the carried out modification on the P&O-MPPT enhanced the PV systems' ability to harvest maximum power output for a longer period.

#### Acknowledgment

The authors are thankful for the kind support from the Egyptian Russian University to carry out the research work.

**Conflict of Interest:** The authors declare that there is no conflict of interest related to the article.

#### REFERENCES

- [1] Z. Didi and I. El Azami, "Experimental analysis and monitoring of photovoltaic panel parameters", *Int. J. of Adv. Comp. Sci. and App.*, vol. 14, no.6 pp. 151-157, 2023.
- [2] N. Priyadarshi, S. Padmanaban, M. S. Bhaskar, F. Blaabjerg, and J. B. Holm-Nielsen, "An improved hybrid PV - wind power system with MPPT for water pumping applications," *Int. Trans. Electr. Energ. Syst.*, vol. 30, no.2 pp. e12210, 2020.
- [3] A. Youssef, M. El-Telbany, and A. Zekry, "The role of artificial intelligence in photo-voltaic systems design and control: a review," *Ren. Sust. Ener. Rev.*, vol.78, pp. 72-79, 2017.
- [4] H. Patel, R. Gajjar, and M. R. Pandya, "Artificial intelligence based MPPT techniques for solar PV system: a review," *J. Emer. Techn. Innov. Res.*, vol. 6, no.5 pp. 212-221, 2019.
- [5] O. B. Belghith, L. Sbita, and F. Bettaher, "MPPT design using PSO technique for photovoltaic system control comparing to fuzzy logic and P&O controllers," *Energ. Pow. Engin.*, vol. 8 pp. 349-366, 2016.
- [6] Y. Liu, H. Huang, J. Huang, and W. Liang, "A particle swarm optimization-based maximum power point tracking algorithm for PV Systems operating under partially shaded conditions," *IEEE Trans. on Ener. Conve.*, vol. 27, no.4 pp. 1027-1035, 2012.
- [7] G. V. Bhau, R. G. Deshmukh, T. R. kumar, and S. Chowdhury, Y. Sesharao, Y. Abilmazhinov, "IoT based solar energy monitoring system", *Mat. Proc.*, vol. 80, no.3 pp. 3697-3701, 2023.
- [8] F. Peprah, S. Gyamfi, M. Amo-Boateng, and E. Buadi, M. Obeng, "Design and construction of smart solar powered egg incubator based on GSM/IoT," *Sci. Afr.*, vol. 17, pp. e01326, 2022.



- [9] N. Priyadarshi, V. K. Ramachandaramurthy, S. Padmanaban, and F. Azam, "An ant colony optimized mppt for standalone hybrid PV-wind power system with single cuk converter," *Ener.*, vol. 12 pp. 1-23, 2019.
- [10] Balamurugan M., Narendiran S., S. K. Sahoo, R. Das, and A. K. Sahoo, "Application of particle swarm optimization for maximum power point tracking in PV system," *3<sup>rd</sup> Int. Conf. on Elect. Energ. Sys.*, vol. 2016, pp. 35-38, 2016.
- [11] B. Amrouche, M. Belhame, and A. Guessoum, "Artificial intelligence-based P&O MPPT method for photovoltaic systems," *Rev. des Energ. Ren. ICRESD-07 Tlemcen*, vol. 2007, pp. 11-16, 2007.
- [12] D. M. Rodríguez, R. Novella, G. Bracho, J. G. Soriano, C. Fernandes, T. Lucchini, and A. D. Torre, R. J. Villanueva, J. I. Hidalgo, "A particle swarm optimization algorithm with novelty search for combustion systems with ultra-low emissions and minimum fuel consumption," *App. Sof. Comp.*, vol. 134, pp. 110401, 2023.
- [13] N. Priyadarshi, S. Padmanaban, J. B. H. Nielsen, and M. S. Bhaskar, F. Azam, "Internet of things augmented a novel PSO employed modified zeta converter-based photovoltaic maximum power tracking system: hardware realisation," *IET Pow. Elect.*, vol. 13, pp. 2775-2781, 2020.
- [14] C. Carvalho and N. Paulino, "On the feasibility of indoor light energy harvesting for wireless sensor networks," *Proc. Tech.*, vol. 17, pp. 343-350, 2014.
- [15] A. Hamied, A. Mellit, M. Benghanem, and S. Boubaker, "IoT-based low-cost photovoltaic monitoring for a greenhouse farm in an arid region," *Energ.*, vol. 16, no.9 pp. 3860, 2023.
- [16] D. D. P. Rani, D. Suresh, P. R. Kapula, C. H. M. Akram, N. Hemalatha, P. K. Soni, "IoT based smart solar energy monitoring systems," *Mat. Tod.: Proc.*, vol. 80, pp. 3540-3545, 2023.
- [17] A. G. Galeano, M. Bressan, F. J. Vargas, and C. Alonso, "Shading ratio impact on photovoltaic modules and correlation with shading patterns," *Energ.*, vol. 11, pp. 852 2018.
- [18] S. Dubey, J. N. Sarvaiya, and B. Seshadri, "Temperature dependent photovoltaic (PV) efficiency and its effect on pv production in the world a review," *Energ. Proc.*, vol. 33, pp. 311-321, 2013.
- [19] R. Foster, M. Ghassemi, and A. Cota, "Solar energy: renewable energy and the environment," CRC Press, New York, USA, (2010).
- [20] K. Hasan, S. B. Yousuf, Mohammad S. H. K. Tushar, and B. K. Das, P. Das, M. S. Islam, "Effects of different environmental and operational factors on the PV performance: A comprehensive review," *Energ. Sci. Eng.*, vol. 10, pp. 656-675, 2022.
- [21] S. Mekhilef, R. Saidur, and M. Kamalisarvestani, "Effect of dust, humidity and air velocity on efficiency of photovoltaic cells," *Ren. Sust. Ener. Rev.*, vol. 16, pp.2920-2925, 2012.
- [22] S. Murali, P. V. Alfiya, D. S. A. Delfiya, S. Harikrishnan, S. Kunjulakshmi, M. P. Samuel "Performance evaluation of PV powered solar tunnel dryer integrated with a mobile alert system for shrimp drying," *Sol. Energ.*, vol. 240, pp. 246–257, 2022.