

# Journal of Engineering Research

---

Volume 7

Issue 5 *This is a Special Issue from the Applied Innovative Research in Engineering Grand Challenges (AIRGEC) Conference, (AIRGEC 2023), Faculty of Engineering, Horus University, New Damietta, Egypt, 25-26 October 2023*

Article 42

---

2023

## A Review of Hybrid Humidification and Dehumidification Desalination Systems

M.A. Elazab, A.E. Kabeel, Maher Rashad Salem, hamouda Abueldahab, Mohamed S. Elhadidy

Follow this and additional works at: <https://digitalcommons.aaru.edu.jo/erjeng>

---

### Recommended Citation

Elazab, A.E. Kabeel, Maher Rashad Salem, hamouda Abueldahab, Mohamed S. Elhadidy, M.A. (2023) "A Review of Hybrid Humidification and Dehumidification Desalination Systems," *Journal of Engineering Research*: Vol. 7: Iss. 5, Article 42.

Available at: <https://digitalcommons.aaru.edu.jo/erjeng/vol7/iss5/42>

This Article is brought to you for free and open access by Arab Journals Platform. It has been accepted for inclusion in Journal of Engineering Research by an authorized editor. The journal is hosted on [Digital Commons](#), an Elsevier platform. For more information, please contact [rakan@aar.edu.jo](mailto:rakan@aar.edu.jo), [marah@aar.edu.jo](mailto:marah@aar.edu.jo), [u.murad@aar.edu.jo](mailto:u.murad@aar.edu.jo).

# A Review of Hybrid Humidification and Dehumidification Desalination Systems

M.A. Elazab<sup>1</sup>, A.E. Kabeel<sup>2</sup>, Maher Rashad<sup>3,4</sup>, H. A. Dahab<sup>5</sup>, Mohamed S. Elhadidy<sup>6</sup>

<sup>1</sup> Faculty of Engineering, Mechanical Power Engineering Dept., Horus University (HUE), Damietta 34517, Egypt – email: mahelazab0@gmail.com

<sup>2</sup> Mechanical Power Engineering Department, Faculty of Engineering, Tanta University, Tanta, EGYPT – email: Kabeel6@yahoo.com

<sup>3</sup> Production Engineering and Mechanical Design Department, Faculty of Engineering, Tanta University – email: Dr.maherrashad@f-eng.tanta.edu.eg

<sup>4</sup> Mechatronics Engineering Department, Faculty of Engineering, Horus University – Egypt, New Damietta, Egypt – email: mrashad@horus.edu.eg

<sup>5</sup> Department of Basic Science, Faculty of Engineering, Horus University (HUE), Damietta 34517, Egypt – email: haboeldahab@horus.edu.eg

<sup>6</sup> Department of Mechatronics Engineering, Faculty of Engineering, Horus University (HUE), Damietta 34517, Egypt – email: melhadidy@horus.edu.eg

**Abstract-** The escalating threat of water scarcity, coupled with the inclusion of numerous countries in the list of water-scarce nations, has elevated the issue of water availability to a paramount concern in today's global landscape. Freshwater sources are becoming increasingly scarce, with their proportional decline steadily progressing. Consequently, a growing number of nations have resorted to the desalination of seawater as a viable solution. In response to this critical need, a surge of studies and research endeavors has been dedicated to the development and refinement of desalination processes. One of the most promising innovations in this field is Humidification-Dehumidification (HDH) desalination technology. This paper aims to delve into the potential of HDH desalination technology and its integration with another advanced desalination method known as a hybrid system. By combining these two distinct approaches, it becomes possible to not only enhance productivity but also address certain limitations inherent in each technology. In this paper, we provide an overview of various desalination processes, shedding light on their classifications and characteristics. Our primary focus, however, lies in exploring how HDH desalination technology can be effectively harmonized within a hybrid system to maximize efficiency and mitigate shortcomings observed in individual technologies. The integration of HDH with existing desalination methods has demonstrated notable success, as evidenced by numerous research studies in the field. This research underscores the significance of hybridization in advancing HDH sustainability practices within the desalination sector, ultimately contributing to the global effort to combat water scarcity. Through the synergy of HDH and hybrid systems, we pave the way for more efficient and effective water desalination methods that hold the potential to alleviate water shortages worldwide.

**Keywords-** Humidification-Dehumidification, Hybrid Systems, Water Desalination, HDH sustainability

## I. INTRODUCTION

Desalination refers to the procedure of extracting dissolved salts from seawater to generate potable water. The predominant methods employed for water treatment globally encompass the membrane desalination technique and the thermal desalination method [1]. A desalination process's major and minor classifications are shown in Figure 1 [2]. Water envelops approximately 75% of the Earth's surface. Within the planet's total water supply, freshwater constitutes a mere 3%, whereas the oceans account for a substantial 97% of the world's saltwater reserves [3]. According to recent estimates, 40 percent of the global population is presently confronting severe water scarcity, and this figure is projected to increase to 60 percent by the year 2025 [4]. Furthermore, approximately 66 percent of the global population, equating to 4 billion individuals, inhabit regions that encounter severe water scarcity conditions for a minimum of one month each

year [5]. For sectoral water usage, livelihoods, ecosystems, and climate change, we must rethink water resource planning and management, including creatively utilizing practical but unconventional water supplies. Adaptability and long-term development in water-stressed nations and populations [6].

About 95.37 million m<sup>3</sup>/day (34.81 billion m<sup>3</sup>/year) is the total desalination capacity of the 15,906 desalination plants currently in operation. Approximately 81% and 93% of all desalination plants ever built have been accounted for by this figure [5]. It is hoped that this brief examination of modern large-scale commercial water desalination systems will help identify possible areas of technological progress for future growth [7]. The desalination potential of nanoparticles has been examined in experimental and computational investigations [8]. Both renewable and non-renewable energy sources are broad classifications that can be applied to the myriad of different kinds of energy sources that are now in use. The term "renewable energy" denotes any type of energy that can be continuously replenished and is derived from natural sources within the environment. This encompasses electricity and heat generated from various sources, such as solar, wind, ocean, hydropower, biomass, geothermal resources, biofuels, and hydrogen derived from renewable sources. More than 130 RED plants have been put into operation over the course of the previous few years [9]. The hybridization of methods used in solar desalination has the potential to increase efficiency [1].

## II. HYBRID DESALINATION SYSTEMS

Combining two or more desalination technologies into a single unit, a hybrid desalination system delivers a more cost-effective end product while also better matching power demand with water requirements and maximizing the benefits of each process [1]. Recently, there has been a significant shift in the desalination sector, where hybrid desalination plants have become more prominent compared to thermal desalination plants. These hybrid facilities utilize a blend of both thermal and mechanical technologies [10]. The ability of hybrid desalination systems to integrate thermal and mechanical desalination in a way that minimizes the drawbacks of each method while maximizing the benefits is a major advantage [10]. Hybridization of desalination processes can reduce energy consumption by overcoming the constraints of each process and taking advantage of their strengths [11]. Wei et al. [12] used integrated/hybrid membrane systems in reverse osmosis desalination operations and water treatment plants. Hybrid desalination procedures have been examined in terms of the approaches utilized to improve hybrid systems [11].

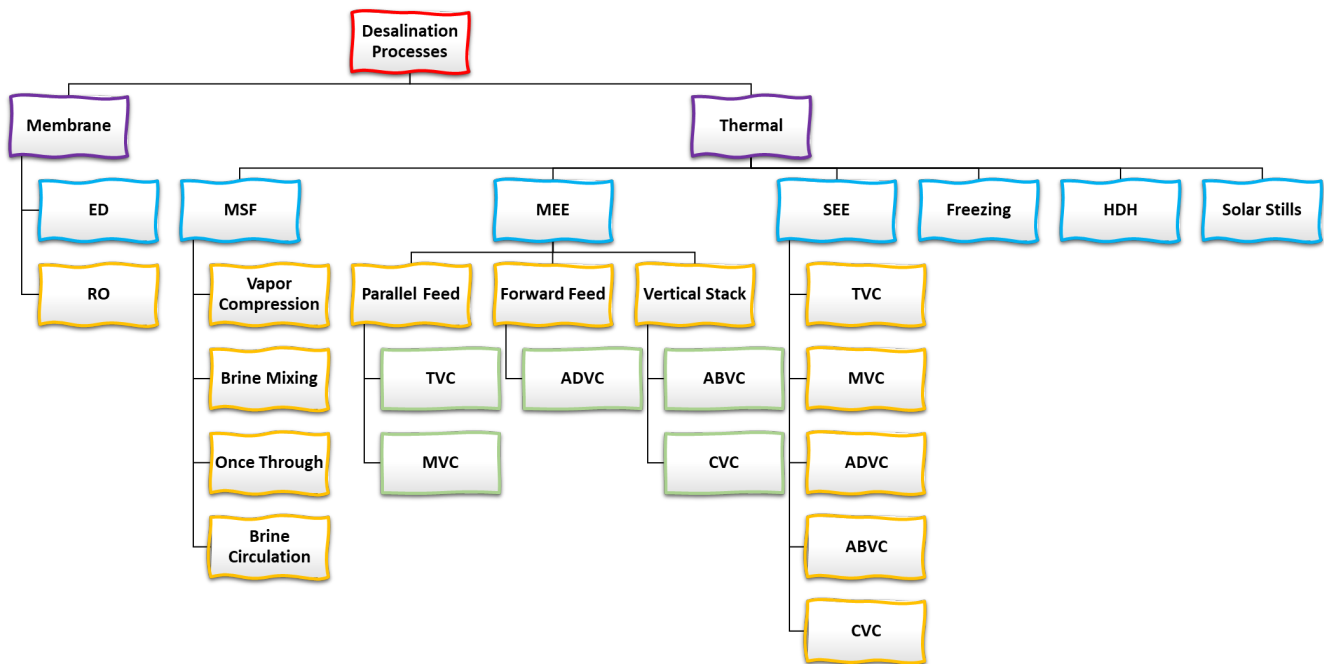

Figure 1. Classification of desalination process [2].

In arid regions characterized by high seawater temperature and salinity, the prevalence of thermal desalination and power plants, often referred to as "dual-purpose" or "cogeneration" plants, is notable [10]. These plants represent an efficient approach as compared to utilizing separate boilers for power cycle and thermal desalination processes. The integrated approach of a dual-purpose plant results in higher overall efficiency than producing electricity and water independently. As an illustration, vacuum membrane distillation (VMD) units and adsorption desalination (AD) units exemplify the hybridization of thermal and membrane technologies [13]. In the realm of water desalination, the concept of hybrid or integrated desalination systems holds significant importance. It entails the amalgamation of at least two processes to achieve more cost-effective water production and to align control requirements with water demands, a feat that neither process can accomplish in isolation. There are two noteworthy advantages associated with integrating desalination with salinity gradient energy harvesting techniques. Firstly, desalination brine can serve as a concentrated solution for power generation. Secondly, the combination of energy harvesting with desalination opens up possibilities for creating self-sustaining desalination systems [11].

### III. HUMIDIFICATION-DEHUMIDIFICATION DESALINATION

The latent heat of condensation is a major source of energy loss in solar stills, which led to the development of the humidification–dehumidification (HD) principle [14]. Desalination technology has been studied extensively by a number of researchers, and it has been found that this method can produce freshwater at high capacity and optimal efficiency [15]. The humidification–dehumidification process offers numerous advantages, particularly its compatibility with low-temperature renewable energy sources [14]. In this process, water evaporates from the seas, condenses into freshwater precipitation, and returns to the Earth, forming a part of the natural water cycle that can be used for drinking.

The sun's energy facilitates the evaporation of seawater, and the resulting vapor condenses on the cooler glazing of the still, where it can be collected for drinking purposes. This represents the fundamental principle underlying a solar still. However, it's worth noting that during the condensation process, all of the latent heat of water evaporation dissipates into the environment, leading to suboptimal thermal efficiency. Humidification is the technique of adding moisture to dry air by introducing water droplets into the mix. When air and water vapor mix, they create a concentration difference, which acts as the driving force behind this diffusion process. Various humidification techniques are employed in desalination processes, including spray towers, bubble columns, wetted-wall towers, and packed bed towers [16]. In these processes, water vapor in the humid air is condensed by a dehumidifier to yield distilled water. Figure 2 illustrates the two fundamental HDH processes. The HDH cycle builds upon this fundamental concept by splitting the evaporation and condensation stages into distinct devices. The latent heat generated during evaporation is subsequently harnessed and employed to heat the ocean, thus contributing to the overall efficiency of the system [14].

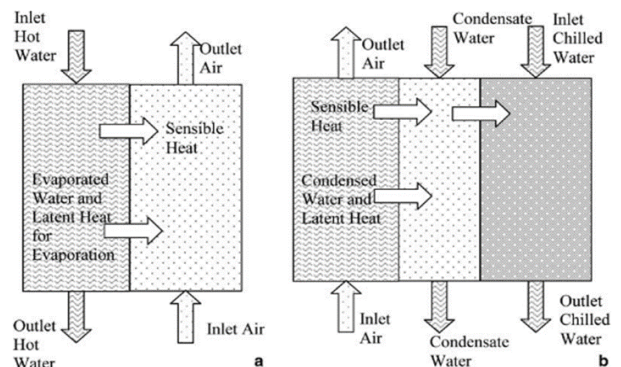

Figure 2. Schematic illustrating the heat and mass transfer processes occurring in both the humidifier (a) and (b) the dehumidifier [17].

HDH systems can be categorized into three fundamental types. The first classification is based on the type of energy employed, which can encompass solar, thermal, geothermal, or hybrid energy sources. This categorization underscores a key advantage of the HDH concept, namely its ability to produce water using low-grade energy, with a particular emphasis on renewable energy sources. A humidifier, a dehumidifier, and a heater are need to be included in HD cycles. Various sorts of cycles can be produced depending on how these three components are ordered [18]. The second classification of HDH processes is determined by the cycle configuration, as depicted in Figure 3. There are various works on cycle configurations in the literature. Important aspects of the system under consideration, as well as key findings from these investigations, are examined and summarized by Abdelmoez et al. [19].

#### IV. HYBRID HDH SYSTEMS

Through the process of hybridization, which involves combining the strengths of two or more processes, it becomes possible to decrease energy consumption while still meeting the desired water production requirements. If you're looking for an effective way to overcome the constraints of a single process to increase overall system performance and/or satisfy specific needs, hybrid processes may be the answer [11]. Another advantage of this technology is its compatibility with various renewable energy sources and its potential for integration with other desalination technologies. This integration can enhance overall output while mitigating potential drawbacks. The most important hybrid HDH systems include the following:

##### A. HDH-TVC

Two HD-TVC cycle designs were numerically studied and optimized in order to identify the greatest possible thermal performance. To keep the suggested cycle's pressure difference constant, compression and expansion devices are used to maintain the pressure disparity. The dehumidifier dehumidifies the humidified carrier gas that exits the humidification chamber in the cycle described in this study (see Figure 4). Using either a throttle or an air expander, the dehumidified carrier gas is then expanded [21]. There is evidence that the most basic HD-TVC setup (GOR 0.8–2.0) performs as well as a standard HD cycle (GOR 0.8–2.0).

##### B. HDH-RO

The integration of HDH-RO resulted in a 50% reduction in product costs compared to using HDH in isolation [22]. Furthermore, research has explored a reverse osmosis humidification-dehumidification system incorporating high-temperature steam-driven humidification-dehumidification with pressure variations [23]. These cycles are thoroughly examined to assess their advantages and drawbacks, with a focus on identifying their respective strengths and weaknesses. Research has been conducted involving the modeling and exergy analysis of an innovative configuration incorporating RO, HDH, and a flat plate collector (FPC). This analysis considers factors such as feed water mass flow rate, chemical exergy, salinity, and applied pressure [24]. A schematic of the new setup is presented in Figure 5. This setup is being investigated for use in conjunction with a concentrated photovoltaic/thermal solar collector capable of generating both electrical and thermal energy. The research focuses on a hybrid reverse osmosis (RO) and humidification-dehumidification (HDH) system. Under steady-state

conditions, this hybrid HDH/RO system, utilizing both thermal and electrical energy, has the potential to produce 38% more freshwater compared to using the entire solar collector output to power a standalone RO system [25].

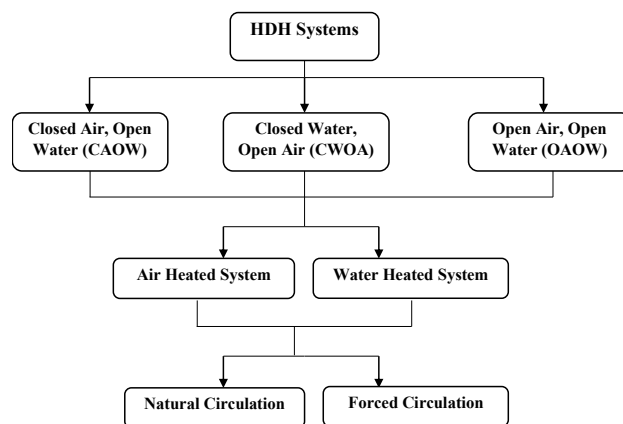

Figure 3. Classification of typical HDH processes based on the cycle configuration [19, 20].

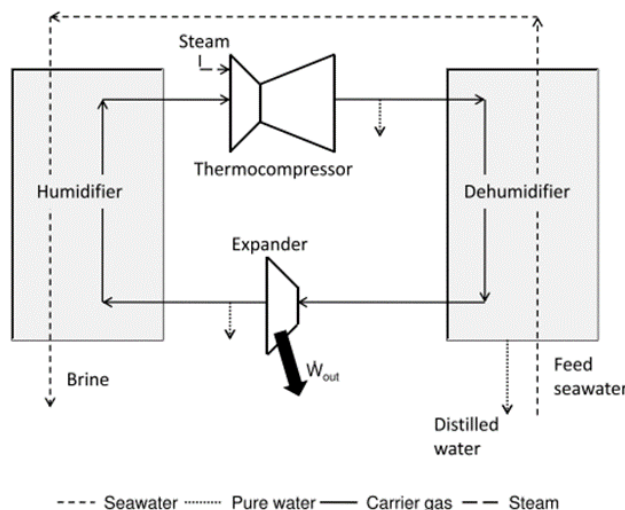

Figure 4. Schematic diagram of basic HDH cycle with TVC and expansion device [21].

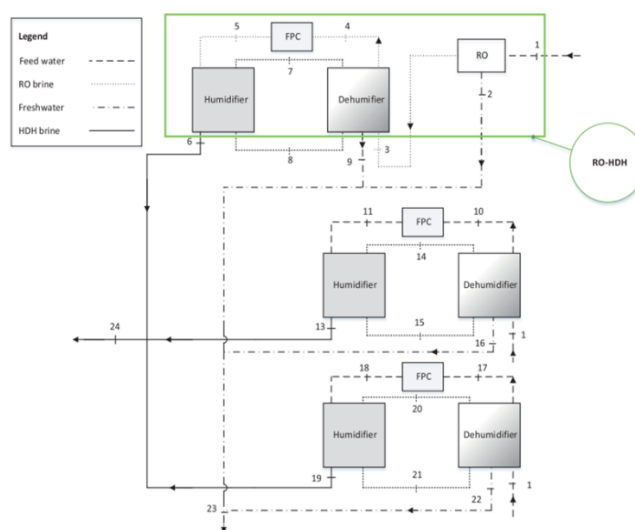

Figure 5. Schematic of the HDH-RO desalination plant [24].



In the study conducted by Jamil et al. [26], the exergo-economics of a desalination system employing a humidification-dehumidification (HDH) process in an open-water, open-air configuration are investigated. Additionally, the study explores the feasibility of connecting a reverse osmosis (RO) system to an HDH unit.

According to the study's findings, the HDH-RO system with a Pelton turbine and the basic HDH-RO exhibit the lowest second-law efficiency. The cost for an electrical heater is \$0.12/m<sup>3</sup>, while a solar heater costs \$0.13/m<sup>3</sup> for the hybrid HDH-RO pressure exchanger.

Abdelgaied et al. [27] have developed a model for an innovative hybrid desalination unit that combines two widely used processes to achieve high freshwater production: HDH and RO (Reverse Osmosis). Figure 6 illustrates the photovoltaic (PV) system employed to provide power for the hybrid HDH-RO unit, ensuring low power consumption. This system incorporates double pass solar air collectors (SACs), thermal energy recovery (TER) units, and evacuated tube solar water collectors (SWCs) to enhance its efficiency. Solar panels' backsides were linked in parallel to TER units, which had a dual purpose: to chill and pre-heat saltwater before it entered the SWC.

### C. HDH-AD

Adsorption bed were cooled with saltwater before entering HDH dehumidifiers in this hybrid system configuration. When the hybrid system was optimized, the GOR of the HDH was approximately 3.5, whereas the GOR of the heat recovery system was around 8 even in its optimal state. In the hybrid HDH-AD system, the indirect heating method resulted in a lower freshwater production compared to the standalone HDH system. However, the cost of freshwater in the hybrid system was significantly lower, at 0.65 ¢/L, which is three times less than that of the standalone HDH system. This cost reduction was achieved despite the lower exchange of heat and water content in the hybrid system [22]. There has been research towards a hybrid HDH system that combines humidification and dehumidification with an extra adsorption phase. Degree of freedom analysis and process modeling for HDH and adsorption units are detailed in [28]. Figure 7 illustrates a Humidification-Dehumidification process that incorporates an air-drying stage through vapor adsorption, coupled with a dual regeneration column for drying purposes.

Qasem and Zubair [29] introduced an innovative combination of adsorption desalination (AD) and a unique humidification-dehumidification (HDH) system to produce freshwater and obtain chilled water for cooling purposes. In two hybrid HDH-AD designs, it is proposed to replace the HDH heater with the AD system's condenser. In Scheme #1, the HDH input saltwater is pre-cooled in the AD evaporator before being fed to the HDH system, while in Scheme #2, seawater is used to chill the adsorption process. Figure 8 illustrates the distinctions between these two schemes.

This investigation has yielded a novel hybridization of the HDH desalination system with the AD desalination cycle. In theory, the proposed AD-HDH hybrid system has the potential to simultaneously produce freshwater and provide cooling capacity [30].

The system's flowchart may be seen in Figure 9. The silica gel-packed adsorption beds in the hybrid system's AD section are depicted in the diagram. A humidifier and dehumidifier make up the HDH component. Through the condenser, water vapor condensation acts as a heating source for the HDH portion of the system.

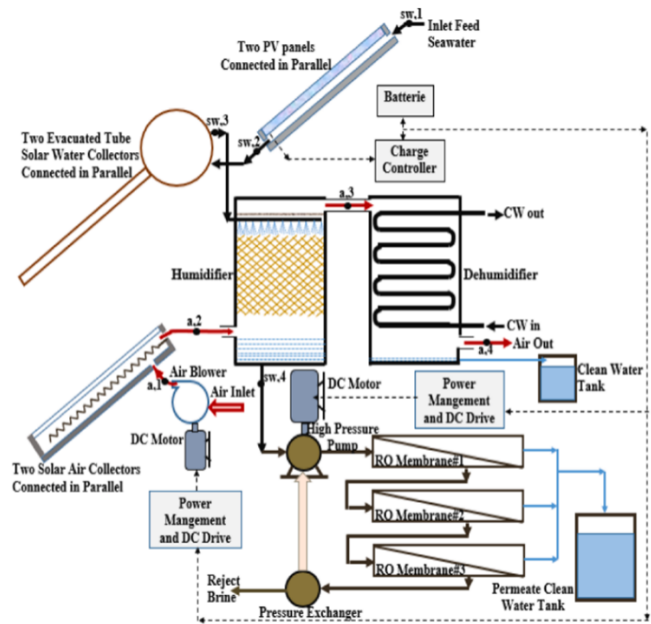

Figure 6. Proposed hybrid HDH-RO desalination system schematic diagram [27].

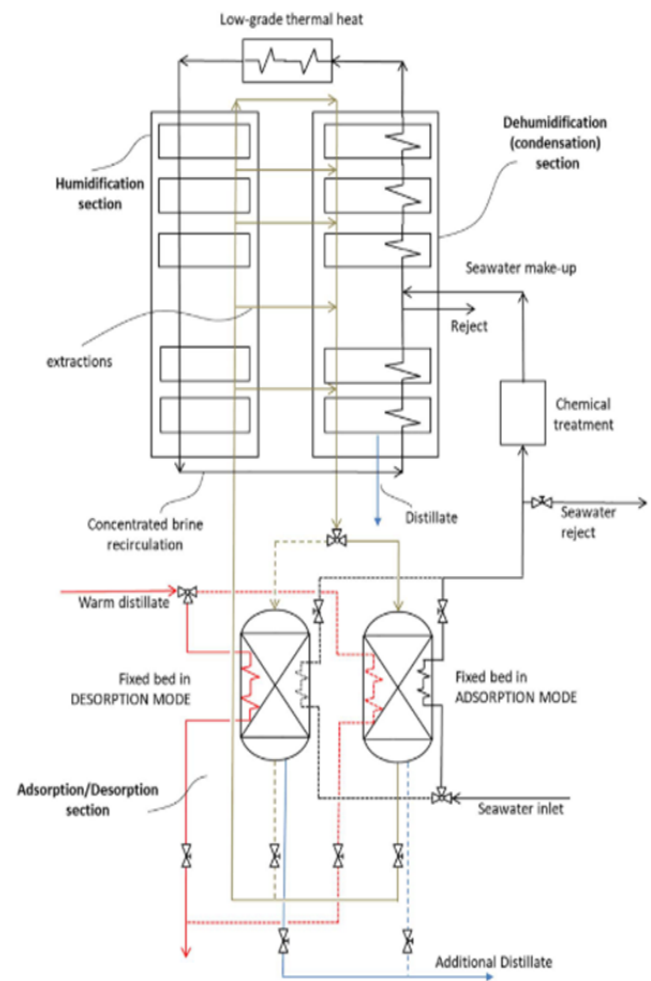

Figure 7. Schematic provided the analysis process of HDH incorporates with Adsorption-Desorption units and Brine Recirculation and the movement of distillate (represented by blue lines), brine (indicated by black lines), and air (depicted in sand-colored lines) within the system. [28].

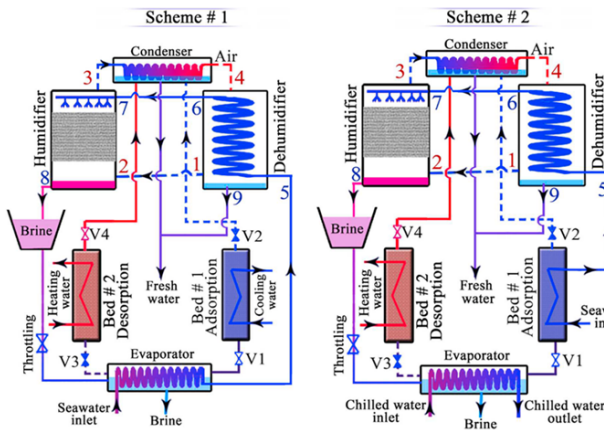

Figure 8. Schematic diagrams of the hybrid HDH and AD systems [29].

The integration of three technologies, namely AD, HDH, and two ejectors, is demonstrated in this configuration. By utilizing two ejectors in conjunction with the HDH cycle, the AD cycle significantly enhances the freshwater production of the hybrid plant, with a tenfold or greater increase in output. Solar thermal energy is used to power the AD cycle in the proposed integrated system (AD2EJ-HDH). Simultaneously, the waste heat generated by the AD cycle is utilized to drive the HDH, leading to an overall improvement in the system's performance [31]. The hybrid system consists of an AD cycle, two ejectors (vapor-vapor and liquid-vapor ejectors), and an HDH desalination unit, as illustrated in Figure 10.

D. HDH-SS

An HDH and SS system might potentially operate together to provide a continuous solar still (SS). In the HDH system, an evacuated solar water collector is employed. The fundamental operation of HDH relies on closed-air and open-water cycles [32]. Two steps are involved in the procedure (see Figure 11). In the initial theoretical and experimental phase, the warm water with a high temperature of 66-75°C from the bottom of the humidifier is directed into an insulated tank. It's expected that in the second (theoretical) phase, the insulated tank's stored water feeds the single-stage SS at 70°C. HDH's warm-water discharge is hot enough to provide SS with water for a whole day.

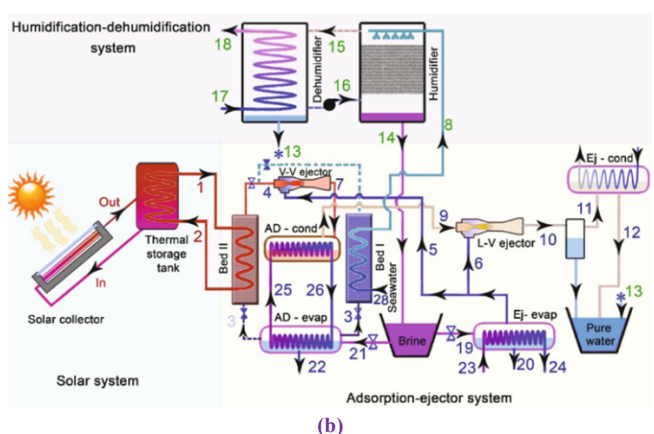
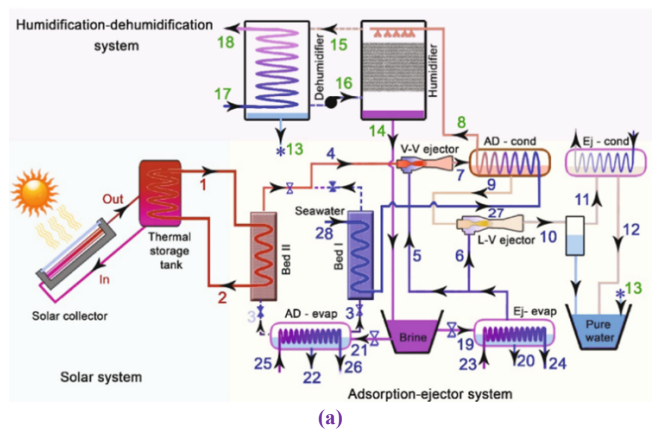

Figure 10. Schematic diagram of (a) AD2EJ/HDH and (b) AD2EJ-HR/HDH systems [31].

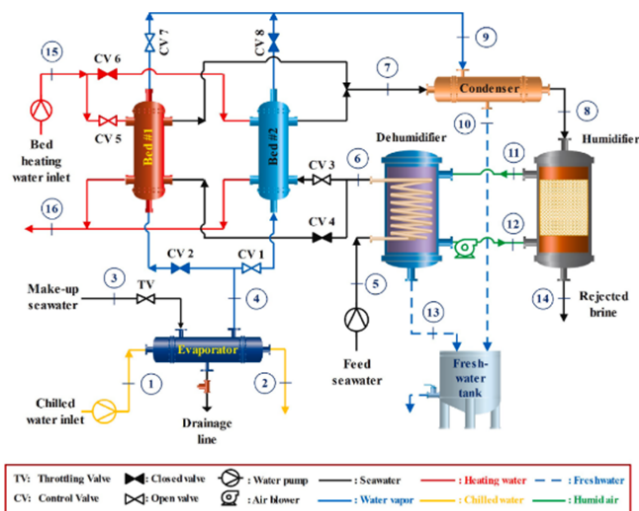

Figure 9. Process flow diagram for the hybrid AD-HDH system [30].

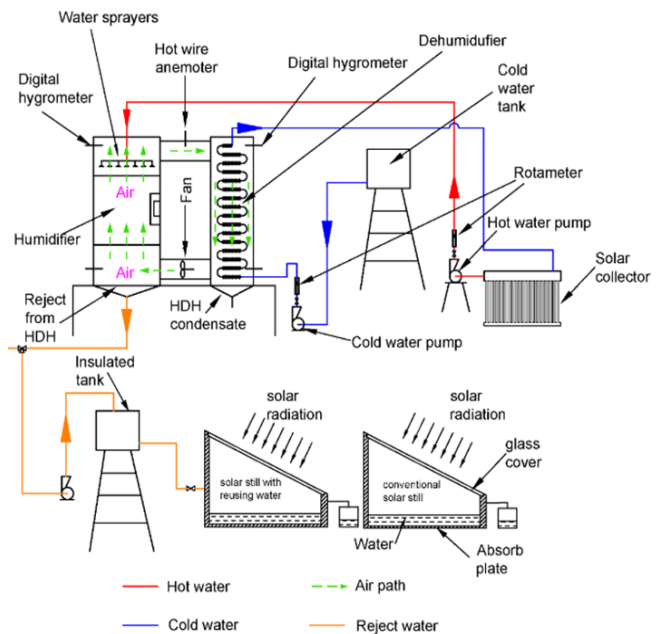

Figure 11. Schematic diagram of HDH-SS experimental setup [32].

Theoretically, a new wick is being studied. In Figure 12, the Humidification-Dehumidification (HDH) unit shows how the still is supplied by the warm water that it rejects. In addition, the effectiveness of glass film cooling is examined. Additionally, the flow of feed water across the wick is taken into account [33]. Using a humidification-dehumidification



system and a cascade solar still, researchers conducted an experiment. The inclining solar stills simultaneously distil and heat water. A variety of operating situations and configurations were also examined to see how they affected the solar system's thermal performance and productivity [34]. The schematic representation of the solar weir cascade still, highlighting the essential components of the humidification tower and condenser, is illustrated in Figure 13.

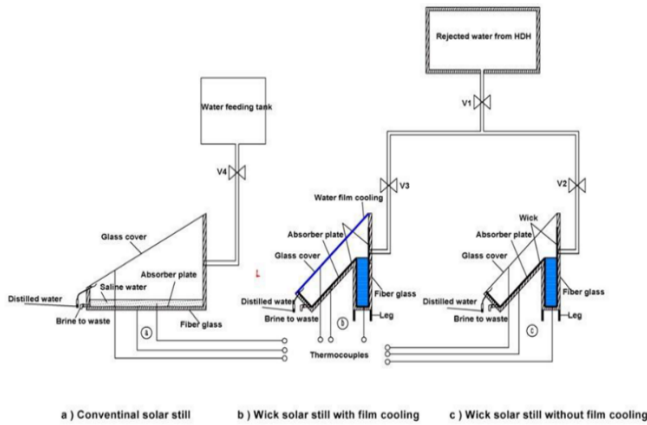

Figure 12. Schematic diagram of the desalination system [33].

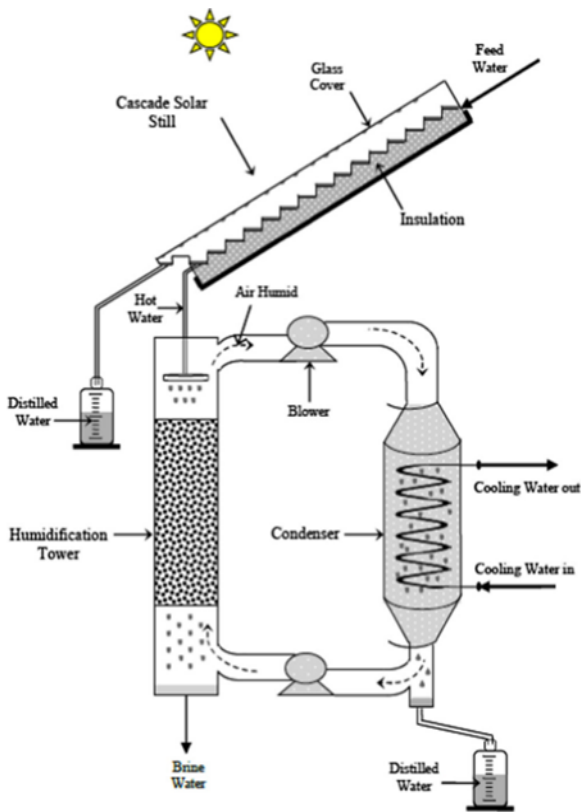

Figure 13. A schematic diagram of the investigated weir cascade solar still coupled with HD system [34].

Kabeel et al. [35] conducted research on utilizing a solar energy-driven water preheater to elevate the temperature of the feed water for both solar stills (SS) and humidification-dehumidification (HDH) systems and circulate it. Figure 14 provides a photograph of the experimental arrangement. The primary objectives of this research were to assess how

different water and air mass flow rates impact system performance and efficiency, as well as to conduct an economic analysis of a hybrid distillation system that combines a solar still (SS) with humidification and dehumidification (HDH). To achieve these goals, an experimental setup was meticulously designed, constructed, and tested. This hybrid system, comprising an HDH unit and six wick solar stills, was evaluated for its performance. Figure 15 provides a visual representation of the experimental test setup. In addition, various packing materials, such as aspen pads and thorn trees, were tested in the humidifier, and water flow rates were examined at 1, 2, 3, and 4 kg/min [36]. Furthermore, another study explored a hybrid system that integrates a solar still with a two-effect humidification-dehumidification desalination system, known as SS-HDH-PV/T. This innovative system employs both closed air and open water loops, as illustrated in Figure 16.



Figure 14. SS-HDH experimental set-up photo [35].

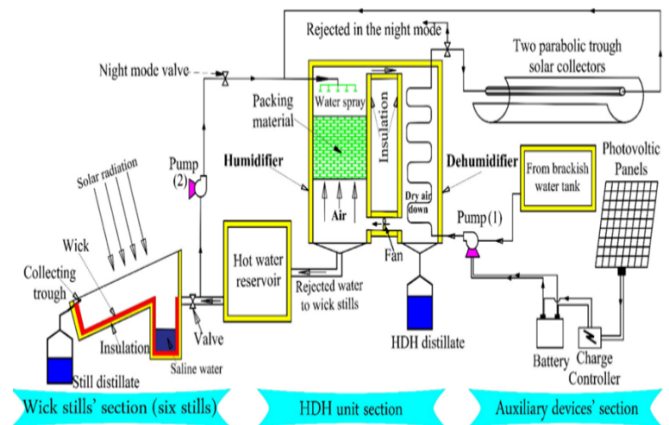

Figure 15. Schematic diagram of the tested SS-HDH system [36].

E. HDH-SSF

Kabeel and El-Said [39] carried out experiments on a small-scale prototype HDH-SSF desalination system that used solar thermal energy for both humidification and dehumidification. Experiment setup diagram is shown in the Figure 17. The HDH-SSF hybrid mode outperformed the separated mode in terms of productivity and production costs [40]. This hybrid system was also subject to numerical analysis [41,42]. The study also involved comparing various configurations of a hybrid solar-powered desalination system for HDH-SSF, as well as testing a different hybrid desalination system. This alternative system includes a nano-fluid solar water heater, a two-stage humidification-dehumidification unit using  $Al_2O_3/H_2O$ , and a single-stage flashing evaporate unit called MSH-SSF.

F. HDH-MD

Two emerging desalination methods, ideal for inland or "zero liquid discharge" (ZLD) purposes, encompass MD and HDH. In the context of desalinating saline groundwaters with TDS levels of up to 6.3%, an MD system was utilized, resulting in brine with a TDS concentration of 10.2% at a daily flow rate of one cubic meter ( $m^3/d$ ). Subsequently, a pilot HDH crystallizer was supplied with this brine.

The MD unit produced distillate with a TDS concentration of  $20\text{ mg/L}$  at a steady flow rate of  $5\text{ L/m}^2\text{-h}$ . Stable MD operation need pre-treatment, which may be accomplished by adding anti-scalant or acid concentrations. In the process of generating additional distillate with a TDS concentration of  $100\text{ mg/L}$ , HDH demonstrated its effectiveness as a crystallizer for MD brine. MD and HDH collectively consumed  $260\text{ kWh/m}^3$  and  $220\text{ kWh/m}^3$  of energy, respectively [45].

G. HDH-MSF

Ongoing research is focused on harnessing energy from a Multi-Stage Flash (MSF) system by implementing a hybrid Multi-Stage Flash Humidification Dehumidification (MSF-HDH) desalination system. For a visual reference, you can consult Figure 18. This innovative hybrid MSF-HDH system enhances overall efficiency and reduces brine discharge. Pre-treated MSF brine is heated to the required temperature for HDH system operation by utilizing the hot condensed steam exiting the MSF brine heater [46].

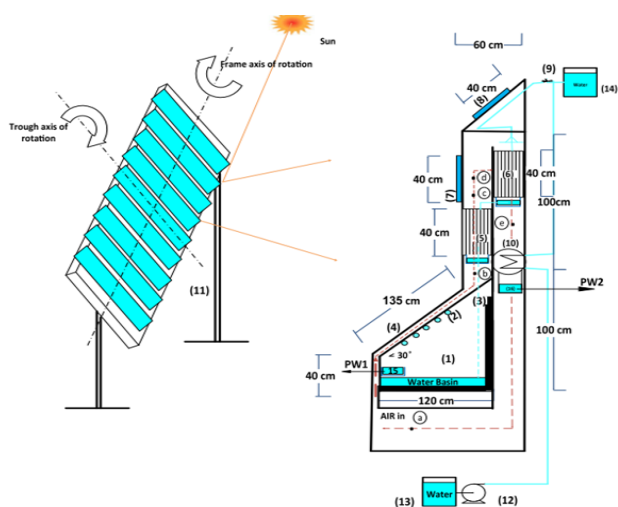

Figure 16. SS-HDH-PV/T Desalination System Schematic [37,38].

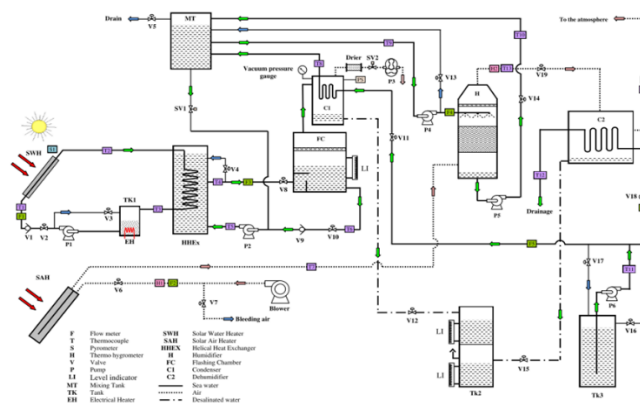

Figure 17. HDH-SSF experimental set-up schematic diagram [39].

H. HDH-SD

A comprehensive experimental investigation was carried out on a solar hybrid HDH-SD desalination system. Figure 19 offers a schematic representation of the air and water flow within this proposed hybrid system, comprising key components such as a humidifier, a dehumidifier, a solar water heater, and a distiller integrated with a solar air heater. The system's performance was rigorously assessed based on various testing and operating parameters, and it achieved its highest productivity, reaching  $6.7\text{ kg/m}^2$  per day, with a production cost of  $10.4\text{ \$/m}^3$ . In evaluating the system's performance, metrics such as system efficiency, humidifier efficiency, and gain output ratio (GOR) were used.

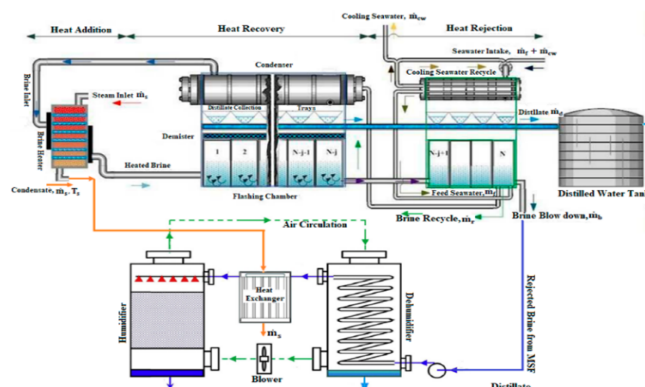

Figure 18. Schematic of HDH-MSF desalination system [46].

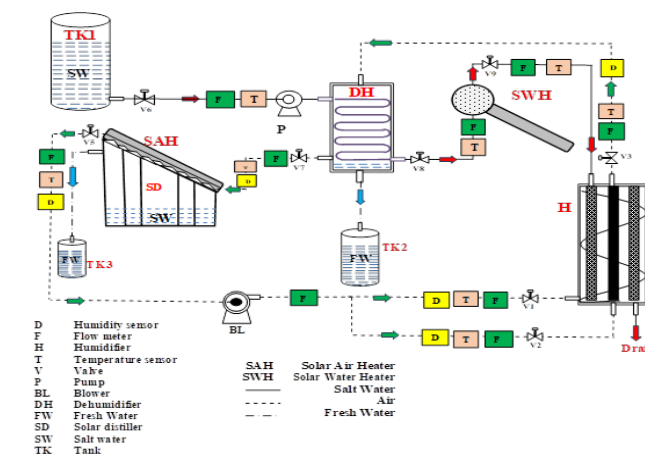

Figure 19. Schematic diagram of the experimental set-up for HDH-SD system [47].





The system demonstrated remarkable performance indicators, achieving a system efficiency of 95%, a humidifier efficiency of 98%, a maximum gain output ratio of 1.65, and an exergy efficiency of 7.2% [47,48]. An exergo-economic analysis for this system has been conducted [49] also, a comparison between different system configurations has been investigated [50].

## V. CONCLUSION

The culmination of our exploration into water desalination systems and processes underscores the paramount importance of freshwater resources. Drawing upon our extensive survey, we derive the following pivotal conclusions:

- It is undeniably evident that Humidification-Dehumidification (HDH) technology is among the most promising techniques in the field of water desalination. Furthermore, it continues to be a subject of ongoing advancement and innovation.
- HDH has numerous advantages, with the most significant being:
  - Simplicity in design and operation.
  - Flexibility for scaling up, rendering it adaptable to diverse production requirements.
  - Favorable operational cost profiles, contributing to economically viable desalination.
  - Operation at lower temperatures, which curtails energy demands.
  - The capacity to harness renewable energy sources to fulfil thermal energy requisites, facilitating seamless integration with sustainable energy solutions.
- Versatility across a broad salinity spectrum, simplifying brine pretreatment and disposal procedures.
- Streamlined operation and maintenance procedures, surpassing the ease of upkeep associated with alternative desalination methodologies.
- Widespread acclaim as a preferred choice for small-scale water production applications, owing to these intrinsic attributes.
- Adaptive components within the system, allowing for optimization of design configurations and the attainment of peak productivity.
- As hybrid HDH systems and other desalination methods are discussed, it becomes clear that hybridization is a good way to combine the best parts of two or more processes into one. This approach not only curtails energy consumption but also effectively meets the imperative objectives of water supply.
- The discernible impact and substantial disparity in performance between standalone HDH systems and their hybrid counterparts manifest themselves unequivocally. This discrepancy is substantiated by the performance metrics delineated in Table 1 for various hybrid systems. Hybrid systems distinctly demonstrate heightened productivity, an elevated GOR (gain output ratio), and corroborated by economic assessments, reduced water production costs.

Table 1. comparison of hybrid HDH systems

System	Type	Energy Source	Max Productivity m <sup>3</sup> /day	GOR	System Efficiency	Exergy Efficiency	Water Cost / l	Remarks	Ref.
HDH-AD	Theoretical	Electrical	30 m <sup>3</sup> /day	7	-	-	-	Enhanced distillate recovery through adsorption-desorption processes on porous materials leads to an increased GOR. Expanding the cycle's temperature range is achieved by reducing the wet bulb temperature of the incoming gas. This, combined with iterative extraction procedures, amplifies the thermodynamic efficiency of the process.	[28]
HDH-AD	Theoretical	Electrical	20–30 kg/h	7.8	-	-	0.64 €/Liter	The performance and energy consumption of HDH are regulated by the Automatic Control (AD) system. Replacing the conventional HDH system with HDH-AD results in a threefold increase in freshwater production costs.	[29]

<b>HDH-CSS</b>	Experimental	Solar	5.4 kg/m <sup>2</sup>	-	39%	-	-	<p>The combination of cascade solar stills with HD (Humidification-Dehumidification) systems enhances efficiency, leading to a performance improvement ranging from 9% to 20% for flow rates within the range of 40 to 150 ml/min.</p> <p>The incorporation of a cascade solar still into the HD (Humidification-Dehumidification) system results in significant improvements, with daily output increasing by 28% to 141% and efficiency rising by 9% to 20% within the flow rate range of 40 to 150 ml/min.</p>	[34]
<b>HDH-SS</b>	Experimental	Solar	18.25 l/ m <sup>2</sup> day	2.57	21% -39%	-	0.0081 US\$	<p>A humidification efficiency of 79% indicates that the process is successful in achieving and maintaining a high level of moisture content in the air or gas being treated.</p> <p>Elevating both temperature and airflow within the system has the effect of augmenting the water output. Changes in temperature and flow rate have a significant influence on the overall system performance.</p>	[35]
<b>HDH-SS</b>	Experimental	Solar	4 kg/min	5.7	-	-	-	<p>The use of Aspen pad packing led to a greater increase in freshwater production compared to the utilization of thorn trees.</p> <p>Utilizing a fan to aid in the removal of wick still water vapor and a dehumidifier to gather and store the condensed water substantially enhances the rate of wick still evaporation.</p>	[36]
<b>HDH-SS</b>	Theoretical	PV-solar concentrator	12 L/m <sup>2</sup>	-	-	-	-	<p>Boosting system productivity can be accomplished by reducing the airflow within the system.</p> <p>Solar concentrators significantly increase the system's output.</p>	[37]
<b>HDH-MSF</b>	Theoretical	-	30,549 m <sup>3</sup> /day	8.73	-	-	1.068 \$/m <sup>3</sup>	<p>The present hybridized desalination approach successfully addresses environmental concerns by effectively recovering freshwater from the warm, concentrated, pretreated, and deaerated brine reject generated during the Multi-Stage Flash (MSF) process.</p>	[46]
<b>HDH-SD</b>	Experimental	Solar	6.7 kg/m <sup>2</sup> per day	1.65	95%	7.20%	10.4 \$/m <sup>3</sup> .	<p>A novel helical humidifier design has been introduced, enhancing the system's performance.</p> <p>The solar distillation system comprises multiple integrated sections, including a solar air heater, to improve its overall efficiency and functionality.</p>	[47]
<b>HDH-TVC-RO</b>	Theoretical	Electrical	8.46 Kg/h	9.46	-	-	-	<p>The HDH-TVC-RO system is designed for desalinating medium-scale saltwater using medium-pressure steam. With the integration of high-efficiency components, this system can achieve a Gain Output Ratio (GOR) of 20 and maintain a low energy consumption rate of 9.5 kWh/m<sup>3</sup>.</p>	[23]
<b>HDH-RO</b>	Theoretical	PV	200 L	-	-	-	-	<p>The water recovery rate ranges from 48% to 49.8%.</p> <p>The specific power consumption (SPC) ranged from 1.22 to 1.24 kWh/m<sup>3</sup>.</p>	[27]
<b>HDH-SSF</b>	Theoretical	Solar	96 l/day	10.2	-	-	12.53\$/m <sup>3</sup>	<p>The specific work consumption is 0.029 kWh/m<sup>3</sup>.</p> <p>In all system designs, the system's operational lifespan has a more pronounced impact on water cost.</p>	[43]



<b>HDH-RO</b>	Theoretical	PV	5.76 m <sup>3</sup> /h	-	-	20.60%	-	This arrangement diminishes the necessity for pressurizing incoming water for HDH/RO units and pretreatment procedures. It's worth noting that the salinity levels of both the brine and freshwater are below 61,866 parts per million (ppm).	[24]
<b>MSH-SSF</b>	Theoretical	Solar	112.5 kg/day	7.5	-	-	6.43 US\$/m <sup>3</sup>	Elevating the nano-particle volume fraction results in increased freshwater output while concurrently reducing the cost of the solar water heater. The specific work consumption of the system stands at 2.32 kWh/m <sup>3</sup> , signifying the energy needed for desalination. Furthermore, the efficiency of the solar water heater is approximately 49.4%, denoting its effectiveness in converting solar energy into heat.	[44]
<b>HDH-AD</b>	Theoretical	Natural gas - PV	21.75 kg/h	2.62	-	-	1.15 €/liter	Hybrid GOR usually exceeds that of standalone HDH, frequently achieving a substantial increase of approximately 350 percent in the GOR value. The hybridization process leads to cost savings, with a documented decrease in water cost typically falling within the range of 30 to 40 percent. From a thermoeconomic perspective, the AD-(water-heated) HDH system demonstrates somewhat poorer performance compared to the air-heated system.	[30]
<b>HDH-SSF</b>	Experimental	Solar	41.8 kg/day	-	-	-	-	The performance of the SSF (Seawater to Freshwater) unit ranges from 0.32 to 1.4, while the flashing temperature varies from 3 to 9 °C. The solar water heater collector exhibits an efficiency of 55%, whereas the solar air heater collector has an efficiency of 56%.	[39]
<b>HDH-SS</b>	Theoretical	Solar	7.15 l/m <sup>2</sup>	-	-	-	-	Implementing film cooling results in a 5.38% boost in daytime productivity and a significant 30% enhancement in nighttime productivity. The production of wick still is significantly higher, with a 278.4% increase compared to traditional basin systems. Similarly, it is 210.2% greater than conventional basin systems, indicating its superior performance in freshwater production.	[33]
<b>HDH-SS</b>	Theoretical-Experimental	Solar	37 L/ day	-	-	-	-	Small-scale HDH or SS (Seawater to Freshwater) units typically exhibit inefficiency when tasked with desalinating brackish or saltwater sources. The practice of reusing exit warm water enhances the production of warm water in SS with HDH by a significant margin, achieving a remarkable 242% increase, while the GOR also experiences a substantial improvement, rising by 39%.	[32]
<b>HDH-AD2EJ</b>	Theoretical	Solar	83.1 m <sup>3</sup> per ton of silica gel per day	2.7	-	-	\$0.54/m <sup>3</sup>	By incorporating a heat recovery circuit, the suggested system showcases significant enhancements, with the Specific Daily Water Production (SDWP) and GOR witnessing a remarkable increase of 180% and 23%, respectively. Furthermore, the heat recovery system boosts HDH's SDWP by an impressive 80%.	[31]



## Statements & Declarations

**Funding:** The authors affirm that they did not receive any financial assistance, grants, or other forms of support while preparing this manuscript.

**Conflicts of Interest:** The authors do not have any pertinent financial or non-financial interests to disclose.

## REFERENCES

- [1] A.E. Kabeel, E.M.S. El-Said, Technological aspects of advancement in low-capacity solar thermal desalination units, *International Journal of Sustainable Energy*. 32 (2013) 315–332. <https://doi.org/10.1080/14786451.2012.757613>.
- [2] H.T. El-Dessouky, H.M. Ettouney, *Fundamentals of Salt Water Desalination*, First edit, Elsevier Science B.V, Netherlands, 2002.
- [3] N. Ghaffour, T.M. Missimer, G.L. Amy, Technical review and evaluation of the economics of water desalination: Current and future challenges for better water supply sustainability, *Desalination*. 309 (2013) 197–207. <https://doi.org/10.1016/j.desal.2012.10.015>.
- [4] I. Ullah, M.G. Rasul, Recent developments in solar thermal desalination technologies: A review, *Energies (Basel)*. 12 (2019). <https://doi.org/10.3390/en12010119>.
- [5] E. Jones, M. Qadir, M.T.H. van Vliet, V. Smakhtin, S. mu Kang, The state of desalination and brine production: A global outlook, *Science of the Total Environment*. 657 (2019) 1343–1356. <https://doi.org/10.1016/j.scitotenv.2018.12.076>.
- [6] M. Qadir, Policy Note: "Addressing Trade-offs to Promote Safely Managed Wastewater in Developing Countries", *Water Economics and Policy*. 4 (2018) 1871002.
- [7] D.S. Likhachev, F.C. Li, Large-scale water desalination methods: A review and new perspectives, *Desalination Water Treat.* 51 (2013) 2836–2849. <https://doi.org/10.1080/19443994.2012.750792>.
- [8] S. Daer, J. Kharraz, A. Giwa, S.W. Hasan, Recent applications of nanomaterials in water desalination: A critical review and future opportunities, *Desalination*. 367 (2015) 37–48. <https://doi.org/10.1016/j.desal.2015.03.030>.
- [9] A. Alkaisi, R. Mossad, A. Sharifian-Barforoush, A Review of the Water Desalination Systems Integrated with Renewable Energy, in: *Energy Procedia*, Elsevier Ltd, 2017: pp. 268–274. <https://doi.org/10.1016/j.egypro.2017.03.138>.
- [10] G.M. Zak, A. Ghobeiry, M.H. Sharqawy, A. Mitsos, A review of hybrid desalination systems for co-production of power and water: Analyses, methods, and considerations, *Desalination Water Treat.* 51 (2013) 5381–5401. <https://doi.org/10.1080/19443994.2013.769697>.
- [11] F.E. Ahmed, R. Hashaikheh, N. Hilal, Hybrid technologies: The future of energy efficient desalination – A review, *Desalination*. 495 (2020). <https://doi.org/10.1016/j.desal.2020.114659>.
- [12] W.L. Ang, A.W. Mohammad, N. Hilal, C.P. Leo, A review on the applicability of integrated/hybrid membrane processes in water treatment and desalination plants, *Desalination*. 363 (2015) 2–18. <https://doi.org/10.1016/j.desal.2014.03.008>.
- [13] Y.D. Kim, K. Thu, K.C. Ng, G.L. Amy, N. Ghaffour, A novel integrated thermal-/membrane-based solar energy-driven hybrid desalination system: Concept description and simulation results, *Water Res.* 100 (2016) 7–19. <https://doi.org/10.1016/j.watres.2016.05.002>.
- [14] E. Mathioulakis, V. Belessiotis, E. Delyannis, Desalination by using alternative energy: Review and state-of-the-art, *Desalination*. 203 (2007) 346–365. <https://doi.org/10.1016/j.desal.2006.03.531>.
- [15] F. Esmaeilion, Hybrid renewable energy systems for desalination, *Appl Water Sci.* 10 (2020). <https://doi.org/10.1007/s13201-020-1168-5>.
- [16] K. Srithar, T. Rajaseenivasan, Recent fresh water augmentation techniques in solar still and HDH desalination – A review, *Renewable and Sustainable Energy Reviews*. 82 (2018) 629–644. <https://doi.org/10.1016/j.rser.2017.09.056>.
- [17] G. Al-Enezi, H. Ettouney, N. Fawzy, Low temperature humidification dehumidification desalination process, *Energy Convers Manag.* 47 (2006) 470–484. <https://doi.org/10.1016/j.enconman.2005.04.010>.
- [18] K.H. Mistry, A. Mitsos, J.H. Lienhard, Optimal operating conditions and configurations for humidification- dehumidification desalination cycles, *International Journal of Thermal Sciences*. 50 (2011) 779–789. <https://doi.org/10.1016/j.ijthermalsci.2010.12.013>.
- [19] W. Abdelmoez, M.S. Mahmoud, T.E. Farrag, Water desalination using humidification/dehumidification (HDH) technique powered by solar energy: A detailed review, *Desalination Water Treat.* 52 (2014) 4622–4640. <https://doi.org/10.1080/19443994.2013.804457>.
- [20] A.E. Kabeel, M.H. Hamed, Z.M. Omara, S.W. Sharshir, Water Desalination Using a Humidification-Dehumidification Technique—A Detailed Review, *Natural Resources*. 04 (2013) 286–305. <https://doi.org/10.4236/nr.2013.43036>.
- [21] K.H. Mistry, G.P. Narayan, A. Mitsos, J.H. Lienhard, Optimization of multi-pressure himidification-dehumidification desalination using thermal vapor compression and hybridization Terms of Use Creative Commons Attribution-NonCommercial-Share Alike 3.0 ISHMT USA 015 OPTIMIZATION OF MULTI-PRESSURE HUMIDIFICATI, 2011. <http://hdl.handle.net/1721.1/71227http://creativecommons.org/licenses/by-nc-sa/3.0/>.
- [22] P.S. Goh, H.S. Kang, A.F. Ismail, N. Hilal, The hybridization of thermally-driven desalination processes: The state-of-the-art and opportunities, *Desalination*. 506 (2021). <https://doi.org/10.1016/j.desal.2021.115002>.
- [23] G.P. Narayan, R.K. McGovern, S.M. Zubair, J.H. Lienhard, High-temperature-steam-driven, varied-pressure, humidification-dehumidification system coupled with reverse osmosis for energy-efficient seawater desalination, *Energy*. 37 (2012) 482–493. <https://doi.org/10.1016/j.energy.2011.11.007>.
- [24] M. Ameri, M.S. Eshaghi, A novel configuration of reverse osmosis, humidification-dehumidification and flat plate collector: Modeling and exergy analysis, *Appl Therm Eng.* 103 (2016) 855–873. <https://doi.org/10.1016/j.applthermaleng.2016.04.047>.
- [25] T. Otanicar, W. Qu, Thermodynamic analysis of hybrid humidification-dehumidification (HDH) - Reverse osmosis (RO) desalination system powered by concentrating photovoltaic/thermal solar collector, in: *AIP Conf Proc*, American Institute of Physics Inc., 2018. <https://doi.org/10.1063/1.5067164>.
- [26] M.A. Jamil, S.M. Elmutasim, S.M. Zubair, Exergo-economic analysis of a hybrid humidification dehumidification reverse osmosis (HDH-RO) system operating under different retrofits, *Energy Convers Manag.* 158 (2018) 286–297. <https://doi.org/10.1016/j.enconman.2017.11.025>.
- [27] M. Abdelgaied, A.E. Kabeel, A.W. Kandeal, H.F. Abosheisha, S.M. Shalaby, M.H. Hamed, N. Yang, S.W. Sharshir, Performance assessment of solar PV-driven hybrid HDH-RO desalination system integrated with energy recovery units and solar collectors: Theoretical approach, *Energy Convers Manag.* 239 (2021). <https://doi.org/10.1016/j.enconman.2021.114215>.
- [28] M. Capocelli, M. Balsamo, A. Lancia, D. Barba, Process analysis of a novel humidification-dehumidification-adsorption (HDHA) desalination method, *Desalination*. 429 (2018) 155–166. <https://doi.org/10.1016/j.desal.2017.12.020>.
- [29] N.A.A. Qasem, S.M. Zubair, Performance evaluation of a novel hybrid humidification-dehumidification (air-heated) system with an adsorption desalination system, *Desalination*. 461 (2019) 37–54. <https://doi.org/10.1016/j.desal.2019.03.011>.
- [30] M.H. Elbassoussi, R.H. Mohammed, S.M. Zubair, Thermoeconomic assessment of an adsorption cooling/desalination cycle coupled with a water-heated humidification-dehumidification desalination unit, *Energy Convers Manag.* 223 (2020). <https://doi.org/10.1016/j.enconman.2020.113270>.
- [31] E.S. Ali, R.H. Mohammed, N.A.A. Qasem, S.M. Zubair, A. Askalany, Solar-powered ejector-based adsorption desalination system integrated with a humidification-dehumidification system, *Energy Convers Manag.* 238 (2021). <https://doi.org/10.1016/j.enconman.2021.114113>.
- [32] S.W. Sharshir, G. Peng, N. Yang, M.O.A. El-Samadony, A.E. Kabeel, A continuous desalination system using humidification - Dehumidification and a solar still with an evacuated solar water heater, *Appl Therm Eng.* 104 (2016) 734–742. <https://doi.org/10.1016/j.applthermaleng.2016.05.120>.

- [33] S.W. Sharshir, M.O.A. El-Samadony, G. Peng, N. Yang, F.A. Essa, M.H. Hamed, A.E. Kabeel, Performance enhancement of wick solar still using rejected water from humidification-dehumidification unit and film cooling, *Appl Therm Eng.* 108 (2016) 1268–1278. <https://doi.org/10.1016/j.applthermaleng.2016.07.179>.
- [34] F. Farshchi Tabrizi, M. Khosravi, I. Shirzaei Sani, Experimental study of a cascade solar still coupled with a humidification-dehumidification system, *Energy Convers Manag.* 115 (2016) 80–88. <https://doi.org/10.1016/j.enconman.2016.02.006>.
- [35] A.E. Kabeel, E.M.S. El-Said, Experimental study on a modified solar power driven hybrid desalination system, *Desalination.* 443 (2018) 1–10. <https://doi.org/10.1016/j.desal.2018.05.017>.
- [36] A.S. Abdullah, F.A. Essa, Z.M. Omara, M.A. Bek, Performance evaluation of a humidification-dehumidification unit integrated with wick solar stills under different operating conditions, *Desalination.* 441 (2018) 52–61. <https://doi.org/10.1016/j.desal.2018.04.024>.
- [37] A. Mahmoud, H. Fath, M. Ahmed, Enhancing the performance of a solar driven hybrid solar still/humidification-dehumidification desalination system integrated with solar concentrator and photovoltaic panels, *Desalination.* 430 (2018) 165–179. <https://doi.org/10.1016/j.desal.2017.12.052>.
- [38] A. Mahmoud, H. Fath, S. Ookwara, M. Ahmed, Influence of partial solar energy storage and solar concentration ratio on the productivity of integrated solar still/humidification-dehumidification desalination systems, *Desalination.* 467 (2019) 29–42. <https://doi.org/10.1016/j.desal.2019.04.033>.
- [39] A.E. Kabeel, E.M.S. El-Said, A hybrid solar desalination system of air humidification, dehumidification and water flashing evaporation: Part II. Experimental investigation, *Desalination.* 341 (2014) 50–60. <https://doi.org/10.1016/j.desal.2014.02.035>.
- [40] A.E. Kabeel, T.A. Elmaaty, E.M.S. El-Said, Economic analysis of a small-scale hybrid air HDH-SSF (humidification and dehumidification-water flashing evaporation) desalination plant, *Energy.* 53 (2013) 306–311. <https://doi.org/10.1016/j.energy.2013.02.042>.
- [41] A.E. Kabeel, E.M.S. El-Said, A hybrid solar desalination system of air humidification-dehumidification and water flashing evaporation. Part I. A numerical investigation., *Desalination.* 320 (2013) 56–72. <https://doi.org/10.1016/j.desal.2013.04.016>.
- [42] E.M.S. El-Said, A.E. Kabeel, THEORETICAL STUDY OF A NANOFUID SOLAR COLLECTOR ASSISTED-HYBRID DESALINATION SYSTEM FOR SMALL COMMUNITIES NEEDS, 2015.
- [43] A.E. Kabeel, E.M.S. El-Said, A hybrid solar desalination system of air humidification dehumidification and water flashing evaporation: A comparison among different configurations, *Desalination.* 330 (2013) 79–89. <https://doi.org/10.1016/j.desal.2013.10.004>.
- [44] E.M.S. El-Said, A.E. Kabeel, M. Abdulaziz, Theoretical study on hybrid desalination system coupled with nano-fluid solar heater for arid states, *Desalination.* 386 (2016) 84–98. <https://doi.org/10.1016/j.desal.2016.03.001>.
- [45] J. Minier-Matar, R. Sharma, A. Hussain, A. Janson, S. Adham, Field evaluation of membrane distillation followed by humidification/dehumidification crystallizer for inland desalination of saline groundwater, *Desalination.* 398 (2016) 12–21. <https://doi.org/10.1016/j.desal.2016.07.006>.
- [46] D. Lawal, M. Antar, A. Khalifa, Integration of an MSF desalination system with an HDH system for brine recovery, *Sustainability (Switzerland).* 13 (2021). <https://doi.org/10.3390/su13063506>.
- [47] A.E. Kabeel, M.R. Diab, M.A. Elazab, E.M.S. El-Said, Solar powered hybrid desalination system using a novel evaporative humidification tower: Experimental investigation, *Solar Energy Materials and Solar Cells.* 248 (2022) 112012. <https://doi.org/https://doi.org/10.1016/j.solmat.2022.112012>.
- [48] A.E. Kabeel, M.R. Diab, M.A. Elazab, E.M.S. El-said, Multi-sections solar distiller integrated with solar air heater : numerical investigation and experimental validation, *Experimental Heat Transfer.* 00 (2023) 1–18. <https://doi.org/10.1080/08916152.2022.2164810>.
- [49] A.E. Kabeel, M.R. Diab, M.A. Elazab, E.M.S. El-said, Hybrid solar powered desalination system based on air humidification dehumidification integrated with novel distiller: Exergoeconomic analysis, *J Clean Prod.* 10 (2022) 401. [https://doi.org/10.1016/s0959-6526\(02\)00002-1](https://doi.org/10.1016/s0959-6526(02)00002-1).
- [50] A.E. Kabeel, M.R. Diab, M.A. Elazab, E.M.S. El-said, Different configuration comparisons for hybrid solar desalination systems : process and performance analyses, *International Journal of Energy and Water Resources.* (2022). <https://doi.org/10.1007/s42108-022-00220-1>.