

Utah State University

DigitalCommons@USU

College of Engineering Magazines

Colleges

12-2018

Utah State Engineer, Fall 2018

College of Engineering

Follow this and additional works at: https://digitalcommons.usu.edu/engineering_magazines

Recommended Citation

College of Engineering, "Utah State Engineer, Fall 2018" (2018). *College of Engineering Magazines*. 11. https://digitalcommons.usu.edu/engineering_magazines/11

This Book is brought to you for free and open access by the Colleges at DigitalCommons@USU. It has been accepted for inclusion in College of Engineering Magazines by an authorized administrator of DigitalCommons@USU. For more information, please contact digitalcommons@usu.edu.





Utah State | **ENGINEER**

2018 A YEAR OF
**STUDENT
SUCCESS**



UtahStateUniversity.



PAYLOAD:

Experimental hybrid CubeSat thruster system and plume contamination sensor package

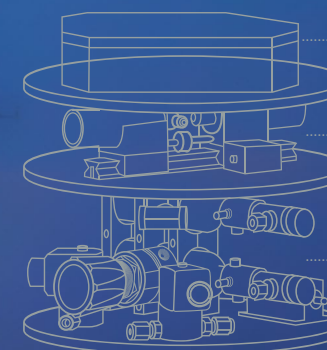

COMPUTER HOUSING

THRUSTERS AND SENSORS

OXYGEN TANKS, REGULATORS AND TUBING

LAUNCH INFO:

MISSION: Flight test green propellant CubeSat thruster system

DATE: March 25, 2018

TIME: 6:51:30 a.m. EDT

LAUNCH LOCATION: Wallops Island, Virginia, ARC Launcher - Pad 2

VEHICLE: Two-stage Terrier-Improved Malemute sounding rocket

MAX ALTITUDE: 600 km

MAX PAYLOAD: 1200 lbs

On March 25, NASA launched a USU student-built experiment into space. The purpose of the mission was to flight test a new environmentally-friendly thruster system created by a professor and students at Utah State University. Photo by Chris Perry/NASA

Flight Tested

USU student-built 'green' thruster technology flies on NASA rocket

Three aerospace engineering students were holding their breath at t-minus zero as their payload rocketed into the early morning skies over Wallops Island, Va. Their innovative technology, invented by USU professor Stephen Whitmore, could revolutionize the small spacecraft industry.

[Learn more on page 24](#)

Utah State Engineer is the annual alumni magazine of the College of Engineering at Utah State University. For delivery information and other inquiries, contact engineering.office@usu.edu. ©2018, Utah State University

Industry Advisory Board

| | |
|---|---|
| TODD ADAMS Utah Department of Natural Resources | KI HO KANG KIHOMAC |
| KATHY ALLMAN Northrop Grumman | JEFFREY KWOK Hill Air Force Base |
| RICHARD ANDERSON Hewlett-Packard (ret.) | EVA NIEMINSKI Utah Dept. of Environmental Quality |
| MARSHA BALA Idaho National Laboratory | JIM NOTTINGHAM Hewlett-Packard |
| VANCE CHECKETT'S EMC-Dell | SCOTTY R. NOWLIN BAE Systems |
| GREG CRANE GE Health Care | REX PLAZIER WesTech Engineering |
| NIEL HOLT Space Dynamics Lab | MARK RIPKE Boeing |
| GEORGE HUMBERT Rocky Mountain Power | STEVEN ROWLAN NUCOR (ret.) |
| LARRY JACOBSEN Campbell Scientific | MEL TORRIE Autonomous Solutions |
| KENT JONES Utah Division of Water Rights | CATHERINE WONG Domo |

On the Cover:

Lucy Campos is preparing for a career in engineering leadership. The environmental engineering student is an undergraduate researcher, she's president of USU's Society of Hispanic Professional Engineers student chapter and she has spent the last five months collaborating on the design and construction of a new student fabrication shop.

Photo by Matt Jensen

Credits:

Managing Editor: Matt Jensen
Art Director: Jamie Lancaster
Graphic Designer: Brooke Nielson
Copy Editor: Maren Aller
Development Assistant: Shelly Wardell



Contents

7 Just the Facts
Here's what you need to know about USU Engineering

19 It Runs in the Family
Brother, sister both lead USU Hispanic student group

31 A New Twist
Engineers put a new twist on Archimedes' screw

8 News & Events
Highlights about student, faculty and staff success

21 A Digital Dilemma
Computer scientist revamps biodiversity software

16 Boa Sorte!
Brazilian Aeronautics Institute signs five year partnership with USU

28 Engineers Without Borders
Student team returns to rural Mexico



Matt Alexandre

34 Aircraft on Demand
Engineering alumnus pioneers new UAV paradigm

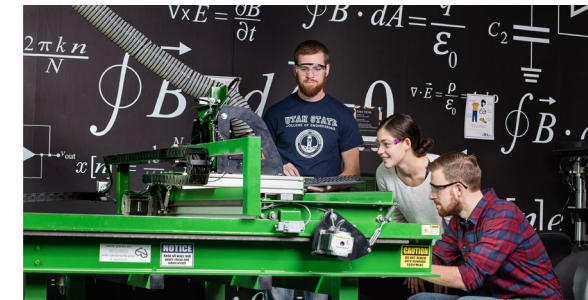

40 What's New?
Check out our new spaces created just for students

To our Alumni, Donors and Friends of the College of Engineering

Whether you're a recent graduate or longtime alum, a lot has changed since we saw you last. The college is growing and changing in ways we didn't imagine a short time ago. In less than one year we have opened four brand new facilities all dedicated to improving the student experience.

Last fall we opened a state-of-the-art design, collaboration and fabrication space called the Idea Factory where students have access to tools and training that will elevate their senior capstone projects to a new level. This summer, we built a new 915-square-foot tutor center, and we continue our popular free in-house tutoring program. We also opened a new student leadership headquarters for the motivated young people who oversee our student chapters and associations. The new space will help foster new networking and leadership opportunities and improve student retention.

In the last few weeks, we've been putting the final touches on our new Metal Factory — a large design and

fabrication facility equipped with everything students need to become experienced designers and creators.

All of this is being done to reach a simple goal: invite more industry collaboration. We want more of our students working alongside Utah's industry leaders and seeing firsthand what a career in engineering or computer science can offer.

We continue to be a leading institution for advanced engineering research supported through funding from state and federal agencies. And thanks to the generous contributions from the David G. and Diann L. Sant family, we created a new endowed professorship that will empower a new generation of the most qualified electrical engineering faculty.

We thank our Industry Advisory Board members for their continued support and direction on how to prepare our students for today's engineering marketplace. Most importantly, we thank our alumni — our Utah State Engineer family. It's thanks to you that our remarkable legacy is expanding. Thank you. ■



Jagath Kaluarachchi,

PhD | PE | D.WRE | FASCE | FEWR
Dean, College of Engineering, Utah State University

USU Engineering at a Glance

We foster a creative and inclusive learning environment where students and faculty are empowered with the knowledge and experience to become the leaders in engineering and computer science who will improve tomorrow's economy, environment and society.

RESEARCH

- \$24.2 million in research expenditures in 2017
- 7 research centers
- 15 patents issued in 2017
- 106 students awarded Engineering Undergraduate Research Program (EURP) fellowships since 2010

ENROLLMENT & DEGREES

- 2,853 undergraduate students, Fall '18
- 347 graduate students, Fall '18
- 393 bachelor's degrees, Spring '18
- 124 master's degrees, Spring '18
- 22 PhDs, Spring '18



BIOLOGICAL ENGINEERING



Civil & Environmental ENGINEERING



Computer SCIENCE

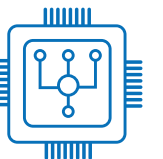

Electrical & Computer ENGINEERING



Engineering EDUCATION

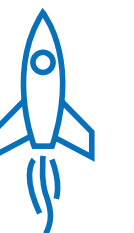

Mechanical & Aerospace ENGINEERING

News & Events

UNPRECEDENTED STUDENT SUCCESS

Three students in the College of Engineering are shaping Utah State University's reputation. They are redefining the term student success and outcompeting their peers from the nation's most prestigious universities.



Darcie Christensen

Darcie Christensen is one of 31 engineering students nationwide to receive a 2018–19 Tau Beta Pi Honor Society academic fellowship. Christensen will receive a \$10,000 cash stipend to advance her graduate studies. She earned a bachelor's degree in biological engineering in 2017 and is currently working toward two advanced degrees: a master's in environmental engineering and a Ph.D. in Engineering Education. The Tremonton, Utah, native serves on the College of Engineering's student leadership council and is an active member of Society of Women Engineers and Tau Beta Pi.

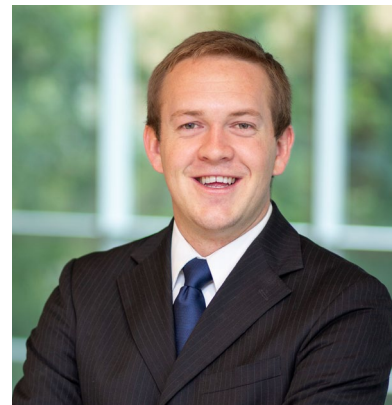

Jeff Taylor

Jeff Taylor is one of five students nationwide to receive a fellowship from NASA's Aeronautics Research Mission Directorate. Taylor will get \$55,000 each year for three years to cover the costs of tuition, fees and professional development. The funding also covers a yearly 10-week stay at NASA's Ames Research Center in Mountain View, Calif., where Taylor will work alongside top NASA engineers. Taylor is from Kaysville, Utah, and has served on the Engineering Council and USUSA. He is also an active member of the American Institute of Aeronautics and Astronautics.



Seth Thompson

Seth Thompson is one of 18 people nationwide to receive a major scholarship from the American Society of Civil Engineers (ASCE). He received the Samuel Fletcher Tapman ASCE Student Chapter Scholarship valued at \$2,300. He was the only student from Utah to receive the award. Other recipients represent Purdue University, MIT, Virginia Tech, Embry-Riddle and other prestigious schools. Thompson, a Payson, Utah native, serves as USU's ASCE student chapter president. He says student involvement has been key to his success as an undergraduate.



USU Students Take Third Place at National Robotics Challenge

Fifteen teams from engineering schools across the Western U.S. competed in this year's E-Fest Student Design Competition organized by the American Society of Mechanical Engineers. The event was held March 23–25 in Pomona, Calif. Students Blake Barber, Maddie Wood, Christian Mayne, Kyler Hendrickson, Anya Neilson, Mason Moore, Brandon Kenison, Ryan Millerberg, Austin Southwick and engineering faculty member Spencer Wendel built multiple small robots designed to play in a four-way soccer tournament.



College of Engineering Lights up Salt Palace at Education Conference

Utah State University was center stage at the Salt Palace Convention Center in June during a major event for engineering education. Educators from around the world came to Salt Lake City for the 125th annual conference and expo of the American Society for Engineering Education. The event drew professors, deans, university administrators and industry representatives together to discuss all things engineering education. USU's College of Engineering sponsored the event which was attended by about 4,000 people. Institutions including Purdue University, University of Michigan, National Science Foundation and Texas Instruments were among the attendees.



Ribbon Cutting Marks Growing University-Industry Partnerships

USU and Rocky Mountain Power officials marked the first phase completion of a new solar array and new electric vehicle charging stations at the Electric Vehicle and Roadway Research Facility and Test Track. The solar panel system was made possible through Rocky Mountain Power incentives and a large Blue Sky grant. The ChargePoint stations were provided through funding from the Utah Sustainable Transportation & Energy Plan initiative administered by Rocky Mountain Power. These two installations and three current research projects represent more than \$1.2 million in funding from Rocky Mountain Power over the past year.

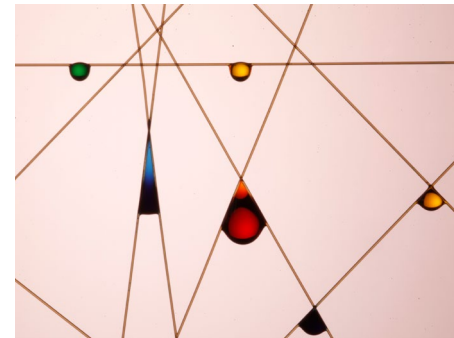

Hanging By A Thread: Why Bent Fibers Hold More Water

Researchers at USU's Splash Lab discovered the exact angle at which a bent fiber holds the most fluid. Their findings were published in the Royal Society of Chemistry's *Soft Matter*. Lead researcher, associate professor Tadd Truscott, says the study offers important insight into fluid dynamics. Truscott compares the bent fiber concept to a spider web. Water droplets attach to the web fibers at various locations, but the largest drops form at intersections made by acute angles. The best angle for a large droplet: 36 degrees. The research has many applications including drug manufacturing and microfluidics.

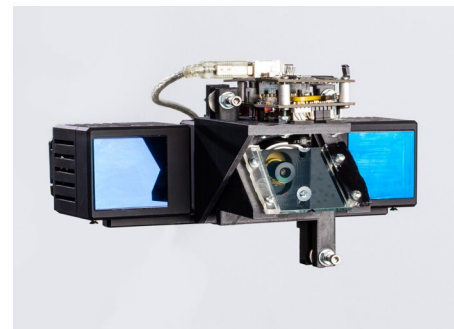

New LiDAR Technology Promises Sharper Aerial Views

Electrical engineering associate professor and researcher Scott Budge received a major research grant to improve the aerial imagery acquired from small, unmanned aerial vehicles. Budge developed a low-cost LiDAR sensor and camera package called the Texel camera. His work will lead to clearer images used to support precision agriculture, watershed science and public safety.



Aerospace Engineer Develops Technology for Dream Chaser Spacecraft

Last fall, the new Dream Chaser spacecraft completed a historic test flight with the help of a new technology developed by aerospace engineering professor Stephen Whitmore. Dream Chaser is a multi-use spacecraft designed to glide back to Earth. The spacecraft determines its air speed using an algorithm that Whitmore patented.



Engineering Education Researcher Partners with National Federation of the Blind

Assistant professor of Engineering Education Wade Goodridge is developing non-visual techniques to teach the fundamentals of engineering to students who are blind or low vision. Goodridge received \$400,000 of a larger \$2 million National Science Foundation grant that was awarded to the National Federation of the Blind in February. Goodridge is overseeing a research study on how to enhance blind students' spatial cognition ability.

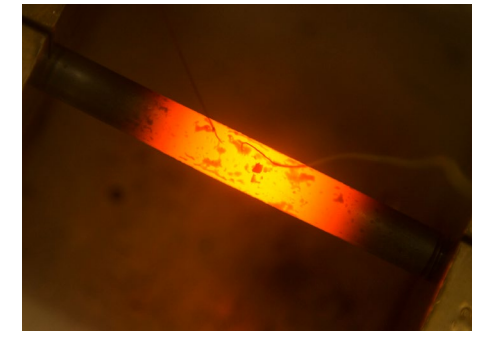

Red Hot: Researcher Develops Imaging Test for Glowing Rocket Engines

Rocket engines get hot! Engineers want to know more about how extreme temperatures affect the structural integrity of rocket engines. Ryan Berke, an assistant professor of mechanical and aerospace engineering, is leading a NASA-funded study to develop a high-speed camera test that captures a never-before-seen perspective of glowing-hot engines. Understanding how engines and nozzles respond to extreme heat is an important step in preventing cracks and other dangerous failures.



Two Faculty Join Dean's Leadership Team

Professors Thom Fronk and Rose Hu joined the dean's leadership team earlier this year. Hu joined USU in Spring 2011 as an associate professor of electrical and computer engineering. She was granted tenure in 2014 and was promoted to full professor in 2017. Before joining USU, she had more than 10 years of R&D experience. Fronk joined USU in 1990 as a faculty in the mechanical and aerospace engineering department. He was promoted to associate professor in 1995.



CEE's David Tarboton Named to AGU Fellowship

Veteran professor, engineer and hydrologist David Tarboton has been named a Fellow of the American Geophysical Union. The announcement was made by AGU President Eric Davidson on Aug. 9. Only one in a thousand members is elected to the AGU Fellowship each year. Tarboton is a professor of civil and environmental engineering with a joint appointment at the Utah Water Research Laboratory. He is revolutionizing the way data are stored and shared among scientists around the globe.



Biological Engineer Elected to AIMBE College of Fellows

Professor Ron Sims was named to the College of Fellows of the American Institute for Medical and Biological Engineering. The organization comprises the most accomplished individuals in the fields of medical and biological engineering. Sims has led a 45-year career in industry, government and higher education. His work has improved public health and environmental sustainability.



Leslie Buxton Named New Advisor of the Year

Buxton joined the College of Engineering in November 2016 and provides advising services for undergraduates in civil, environmental and mechanical engineering. In June, she received the USU 2018 Outstanding New Advisor award. Buxton says she enjoys both the challenges of her career and working with engineering students.



USU Steel Bridge Team Takes Third at Regionals

USU engineering made a top-three spot at ASCE's 2018 Rocky Mountain Regionals Conference. The event was held April 5-7 at the South Dakota School of Mines & Technology in Rapid City, S.D. The competition lets students apply their technical skills to a real-world experience by building a small steel bridge. Each bridge must pass several requirements, including fast assembly and the ability to hold up to 2,500 pounds.

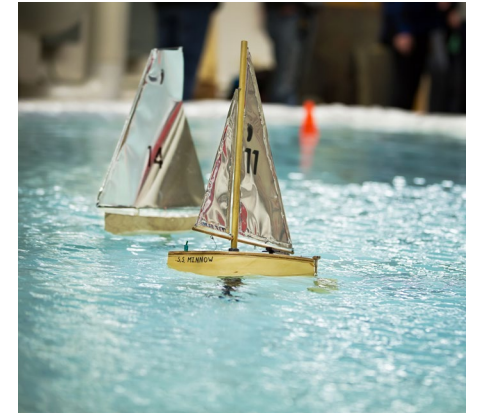

Ahoy, Aggies: First-Year Students Learn to Sail

In landlocked Utah, freshmen engineering students get a hands-on lesson in sailing the open seas. Students in the introductory engineering course design and build radio-controlled sailboats and race them in a shallow indoor pool built specifically for this unique student experience. Instructor Kathryn Graham says the experience shows students the connection between design and problem solving.



27 Years Young: Engineering State Summer Camp Going Strong

Future engineers from seven states converged on the USU Logan campus in June for the 27th annual Engineering State youth summer camp. A total of 212 participants, including 58 young women, took part in the four-day event featuring hands-on challenge sessions, tours of the Space Dynamics Lab and a barbecue bash at First Dam. Registration for Engineering State 2019 opens Jan. 1. Visit estate.usu.edu to learn more.

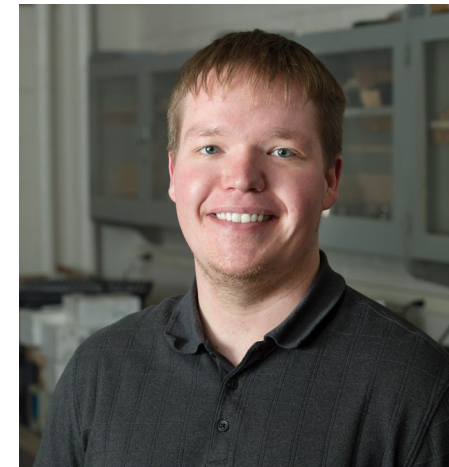

Two Aggie Engineers Receive NSF Fellowships

USU engineering alumni Darcie Christensen and Trevor Bird received the prestigious National Science Foundation Graduate Research Fellowship Award. Christensen ('17) earned a bachelor's degree in biological engineering and is now a PhD student in USU's Department of Engineering Education. Mechanical engineering alumnus Trevor Bird ('17) is working toward a Ph.D. at Purdue University. The award will help cover the costs of graduate school and open new doors for the future engineers.



V. Dean Adams Retires from College of Engineering

The USU community extended a heartfelt congratulations and farewell to professor V. Dean Adams who officially retired from his role as executive associate dean of the College of Engineering in June. Adams joined the leadership team in 2012. He served as associate dean for undergraduate academic affairs and as head of the Department of Engineering Education. Adams provided valuable service in building the reputation of the college and expanding academic services.

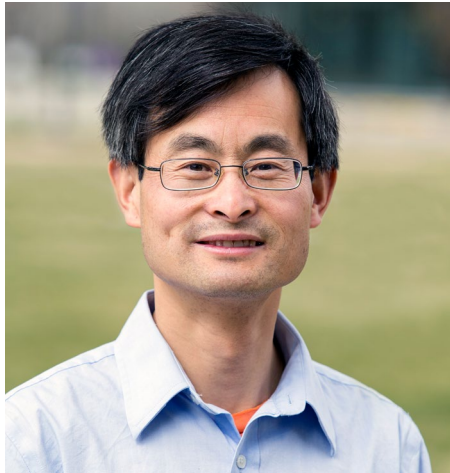

Veteran Educator Named Interim Department Head

An award-winning educator and engineer has been named interim head of the Department of Engineering Education. Professor Ning Fang brings twenty years of industry experience from the Ford Motor Company and a wealth of teaching and research expertise. Fang specializes in teaching foundational engineering courses and educational and assessment courses. His research interests include teaching and learning technologies that improve student problem solving.

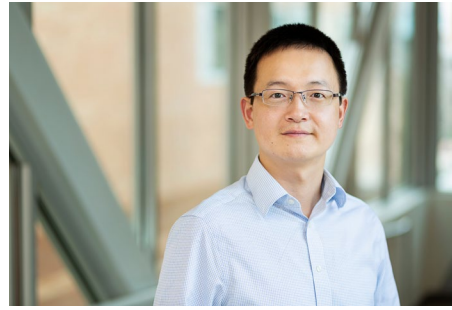

Two Major Research Grants Awarded to MAE Faculty

Assistant professor **Ling Liu** was recently awarded the NSF CAREER Award for his work in understanding and designing materials at the molecular level. He and his colleagues are working to understand how various natural and synthetic materials formed through hydrogen bonds can improve thermal transport efficiency across a range of applications.

Assistant professor **Doug Hunsaker** is one of 32 nationwide recipients of the ONR Young Investigator Program award. He's leading an innovative study to develop next-generation, tailless, morphing aircraft. His research will lead to advancements in aircraft efficiency and noise reduction in both military and civilian aviation.



How Much is Too Much? New Online Tool Estimates Snow Load

Structural engineers now have access to a free online tool that estimates snow load requirements for new homes and buildings. Civil engineering faculty Marc Maguire developed the software with help from the Structural Engineers Association of Utah and industry sponsors. Users simply input a street address or latitude-longitude coordinates and the software calculates snow load in pounds per square feet or kilopascals. Try the new tool for yourself by visiting utahsnowload.usu.edu

Ready to Change Engineering?

The First and Only 100% Online Graduate Certificate of Engineering Education

ceed.usu.edu

- ▶ Become a **Better Educator**
- ▶ Earn Your Certificate In **One Year**
- ▶ Build a World-Class **Teaching Portfolio**

SCAN NOW to learn more about the CEED program





ITA's Rector Anderson Ribeiro Correia, left, USU Provost Frank Galey, right, and professor Charles Swenson, middle back row, met in August to kick off a five-year partnership that facilitates the exchange of research efforts and scientific knowledge.

USU Launches Partnership with Brazilian Aeronautics Institute

Two global leaders in aerospace engineering education are joining forces. Administrators from Utah State University and Brazil's Instituto Tecnológico de Aeronáutica located in São Jose dos Campos signed a memorandum of understanding on Aug. 6 to coordinate research efforts and exchange scientific knowledge.

The document, signed by USU's President Noelle Cockett and ITA's Rector Anderson Ribeiro Correia, kicks off a five-year partnership. USU Provost Francis D. Galey led the signing event. University leaders say the arrangement provides a unique opportunity for the two organizations to pursue joint research and exchange faculty and students.

USU's relationship with ITA goes back several years. Charles Swenson, a USU professor of electrical engineering and director of the USU Center for Space Engineering, has worked with many of Brazil's science and space agencies. His ongoing research into space weather and its effects on global communication and navigation is particularly relevant in Brazil. The country's northern regions are susceptible to an upper atmospheric phenomenon that disrupts GPS and radio communications.

Swenson is the deputy principal investigator on a joint NASA-Brazil CubeSat mission formed to study the problems and potential solutions. A CubeSat is scheduled to be launched

to an Earth orbit approximately 217–248 miles high (350–400 km). Its operational phase is expected to last at least a year. ■



Professor and Student Patent New Heart Rate Estimation Technology

Researchers in the Electrical and Computer Engineering Department don't need an Apple Watch or stethoscope to measure your heartbeat. They only need a video camera.

Professor of electrical engineering Jake Gunther and his former student Nate Ruben are the inventors of a USU-patented technology that estimates heart rate using a video camera and specialized software.

“When your heart circulates blood through your arteries and veins, the light absorbed by your skin changes by measurable amounts,” says Gunther. “You can't see it with the naked eye, but when our system processes the images from a camera, the changes are obvious.”

Video cameras record images in values of red, green and blue. The green channel provides information that makes heart rate estimation possible.

“Hemoglobin in the blood has an absorption peak for green light,” said Gunther. “So when the heart pushes blood into arteries near the skin, more green light is absorbed and less is reflected. This means we see fewer green values in the images from the camera.”

The system processes the color



Electrical engineering alumnus Nate Ruben, left, and ECE professor Jake Gunther are the inventors of a technology that estimates heart rate using only a video camera and special software.

data and computes an average over regions of the image where skin is visible on the face, neck or arms. This contact-less monitoring system could revolutionize medical equipment and consumer products including baby monitors and exercise gear. A future version of the inventors' design could even replace hospital tools that monitor blood pressure or blood-oxygen levels.

“The operation of our system is similar to a pulse oximeter,” said co-inventor and USU alumnus Nate

Ruben. “But instead of looking at the light transmitted through skin tissue, we're looking at the light being reflected from it.”

The inventors are expanding their patented technology with the creation of a new company called Photorithm. Gunther and Ruben are also developing a new baby monitor system called Smartbeat that uses similar software to detect breathing in a sleeping infant. They say the technology will be a game changer. ■

Have You Heard of SHPE?

The Society of Hispanic Professional Engineers is quickly becoming one of Utah State University's most active student organizations. Members get career development and service opportunities, learn leadership skills and connect with top industry leaders to find meaningful engineering careers and internships.

SHPE's mission at USU is to change the lives of its members by empowering the Hispanic and Latin@ community to realize its fullest potential and to impact the world through STEM awareness, access, support and development.

Faculty advisor, assistant professor Idalis Villanueva, says SHPE offers a two-fold mission which benefits both student members and residents



Above: Jorge Espinoza, professor Idalis Villanueva, Lucy Campos and Paola Muñoz participated in the 2017 national SHPE conference in Kansas City, Mo. Below: Students participate in SHPE events, including a regional conference held at Utah State University in 2015.

in the local community.

“We communicate with the Hispanic community culturally and linguistically to discuss the importance of engineering careers,” she said. “We support parents and students in college admission procedures, and we motivate children to pursue engineering or STEM careers through our continual presence in their lives.”

SHPE leaders envision a world in which Hispanics are highly valued as influential innovators, scientists,

mathematicians and engineers.

SHPE has an active outreach mission. Each year student members organize several events for grade school students. Events include Science and Engineering Day for 4th–8th graders, the Science Unwrapped lecture series and the Cache Makers engineering and design workshop for Cache Valley kids ages 6–12. ■



A SHPE Family Success Story

Lucy Campos and her brother José don't shy away from responsibility. The Brownsville, Texas natives — one now a junior engineer at Boeing — both studied engineering at USU and served as president for the Society of Hispanic Professional Engineers student chapter.

Lucy Campos is the current SHPE chapter president. She also works as an undergraduate researcher alongside professor Idalis Villanueva. Campos collaborated on the design and construction of the new Metal Factory student fabrication space. She says her SHPE experience is preparing her for an exciting future.

“Being a leader in SHPE has taught me the importance of reaching out to create bigger networks and to help others reach their full potential. I have learned to work on a team and listen to ideas that enrich our community. This organization helps me feel like I belong, like I'm a part of something big and important.”

José Campos (BS, '16) served in SHPE leadership roles for three years. He was instrumental in organizing several successful events including a college admissions workshop for local Hispanic parents and a SHPE regional conference held at USU in 2015.

After participating in local and national SHPE conventions, he landed internships at Inovar, Delta Airlines and Boeing's Engineering Career Foundation Program.

Today, he's an engineer at Boeing working on the 787 Dreamliner program in Charleston, S.C.



Lucy CAMPOS

- Major: Environmental Engineering
- SHPE Chapter President
- Undergraduate Researcher
- Metal Factory Student Lead

José CAMPOS

- Mechanical Engineering Alumnus (BS '16)
- Former SHPE Chapter President, PR Chair and Regional Conference Chair
- Current Multi-Skill Engineer at Boeing in South Carolina



Computer Science Students Hack Homelessness

Computer science and engineering students from across Utah met on the USU campus last fall for the third-annual HackUSU event.

About 250 students took part in the 36-hour hackathon Nov. 17–18. The event gave participants an opportunity to develop a unique app or technology designed to solve a problem encountered in technology or programming.

A team of USU computer science students took first place for their app designed to combat Utah's growing homelessness problem. Team 'Homeless QRypto' designed an app that allows users to donate Bitcoin currency to panhandlers. The app eliminates the transfer of physical currency and lets the donor designate which type of goods or services the recipient can spend the currency on.



Computer science student Haley Manning coordinated multiple HackUSU events at the Logan campus.

Throughout the hackathon, participants heard from experts on Utah's homelessness problem. Drew Mingl, Utah's open data coordinator, provided access to the state's open data portal. Users accessed millions of lines of data related to poverty and income, housing, public health and other social services. ■



Hack USU gives participants an opportunity to develop a unique app or technology designed to solve a problem encountered in technology or programming. Engineering and computer science students from across the region convene in Logan each year for this popular event.

A Digital Dilemma

USU computer scientist revamps biodiversity software

In the United States, we've accumulated an estimated 500 million specimens of animals, plants, bugs and mushrooms. The specimens are an important resource for scientists, but only 15 percent of the giant collection has been digitized for use in our modern, connected world.

Part of the problem is a lack of robust software tools that can handle such a big job. This digital dilemma creates a unique opportunity for collaboration among biologists and computer scientists. USU's Curtis Dyreson, an associate professor of computer science who has more than a decade of experience in bioinformatics, is leading a major effort to overhaul Symbiota — one of the most widely-used biodiversity database platforms in the world.



"Symbiota is an open-source software tool used to create and manage biological specimen data," said Dyreson. "Scientists use it to document specimens from around the world."

The software is a popular tool, but it's not perfect. "Symbiota was created about 15 years ago, and since then, software development has changed so much," he added.

"We're going to completely revamp it."

The updated software, dubbed Symbiota2, will work on mobile devices and will feature new web compatibility services along with the latest plugin architecture. Symbiota2 will also feature an improved layout and a new feature known as 'Auto Awesome.'

"Auto Awesome is a function that was introduced years ago by the Google Photo Assistant," said Dyreson. "In our application, we



Professor Curtis Dyreson

want to make Symbiota2 do certain things to improve data analysis automatically."

Dyreson is a database expert who's worked on dozens of life science applications. In June, he was awarded a \$780,000 National Science Foundation grant to oversee the Symbiota2 project. Collaborators include USU Department of Biology faculty Mary Barkworth and Will Pearse, along with Neil Cobb and Ben Brandt of Northern Arizona University. As Dyreson explains, it's an ambitious project.

"There's still a long way to go in digitizing all these collections. Our goal is to increase the number of digitized collections and improve data analysis. When more of these collections become digitized, scientists will have access to more data. With more data, we can start to uncover patterns and perform data analysis that was never possible before. For example, we'll see how climate change impacts a species because we'll have a larger digitized historical record. But we can't do any of that until we improve Symbiota." ■



CIVIL & ENVIRONMENTAL Engineering

USU Leads \$4M Collaborative Water Research Initiative

National Science Foundation grants enhance data-sharing tool developed by hydrologists

Utah State University hydrologists are revolutionizing the way scientific data is stored and shared among scientists around the globe. Professor David Tarboton is leading a \$4 million National Science Foundation-funded collaborative effort aimed at improving HydroShare — an online database system that simplifies the storage and sharing of hydrological data and models.

“HydroShare is an online system for the scientific community that allows us to easily and freely share products from our research,” said Tarboton, a professor of civil and environmental engineering and a leading hydrology expert who helped create HydroShare. “We’re interested in sharing not just the scientific publication summarizing a study, but also the data and models used to create that study.”

Sharing scientific data helps researchers collaborate and improves the quality of data. Enhancing HydroShare’s capabilities will help hydrologists and a broad community of Earth-science researchers transform data-sharing techniques and improve scientific knowledge. Upgrades to HydroShare include enhancements to data-sharing tools and new features that enable its 1,000-plus users to develop apps to access HydroShare resources.

“HydroShare represents the latest thinking in collaborative hydrology research,” said Tarboton. “This program serves a diverse community of researchers ranging from hydrologists and environmental engineers to aquatic ecologists.”

HydroShare will play an important role in understanding the devastating flooding events



Professor David Tarboton

from Hurricanes Harvey and Irma. Tarboton and collaborators at The University of Texas at Austin are using HydroShare as a key resource for understanding how such large and sustained flooding and rainfall events occur and how critical infrastructures should be designed to better withstand extreme weather events. ■

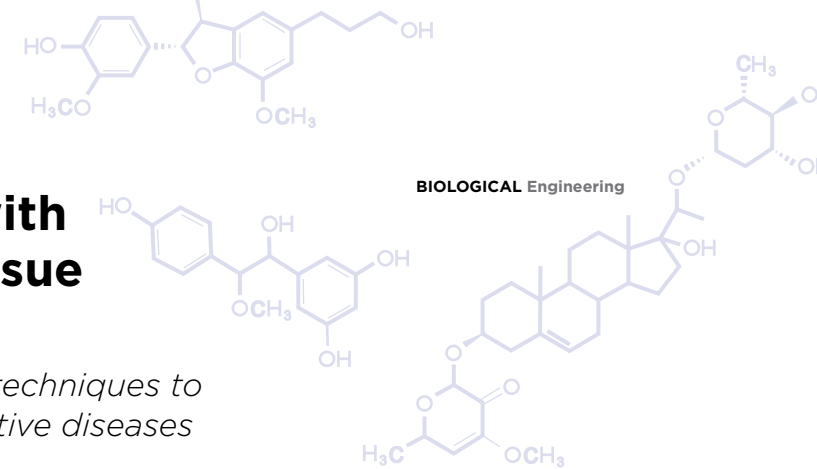

BIOLOGICAL Engineering

Combating Alzheimer’s with 3-D Engineered Neuro Tissue

Biological engineers develop tools and techniques to uncover novel drugs for neurodegenerative diseases

Biological engineers at USU are developing new tools to combat the debilitating effects of Alzheimer’s and Parkinson’s disease and other brain disorders. Graduate students Gregory Jensen and Christian Morrill and assistant professor Yu Huang are using 3-D tissue engineering to develop drugs that combat neurodegenerative diseases.

“One of the problems we’re addressing is inflammation,” said Jensen. “Neurodegenerative diseases cause inflammation in the central nervous system which leads to permanent neural damage and

subsequent problems.”

Researchers believe the inflammatory response is a key force behind the progression of neurodegenerative diseases.

“This is why we’re focusing on better understanding anti-inflammatory compounds,” said Huang. “We need to find more effective anti-inflammatory agents and better methods to deliver them to sites where neuroinflammation and degradation are taking place.”

The team uses an engineered substrate material that allows cells

to grow in a 3-D structure. The approach mimics normal cell growth in the human body.

“3-D tissue engineering is also useful for localized drug delivery,” said Jensen. “3-D tissue constructs can be engineered to match specific tissue types and can be loaded with a desired pharmaceutical compound that can be delivered to a precise location.”

The team recently published new findings about their pharmaceutical science research in the journal *Acta Pharmaceutica Sinica B*. ■

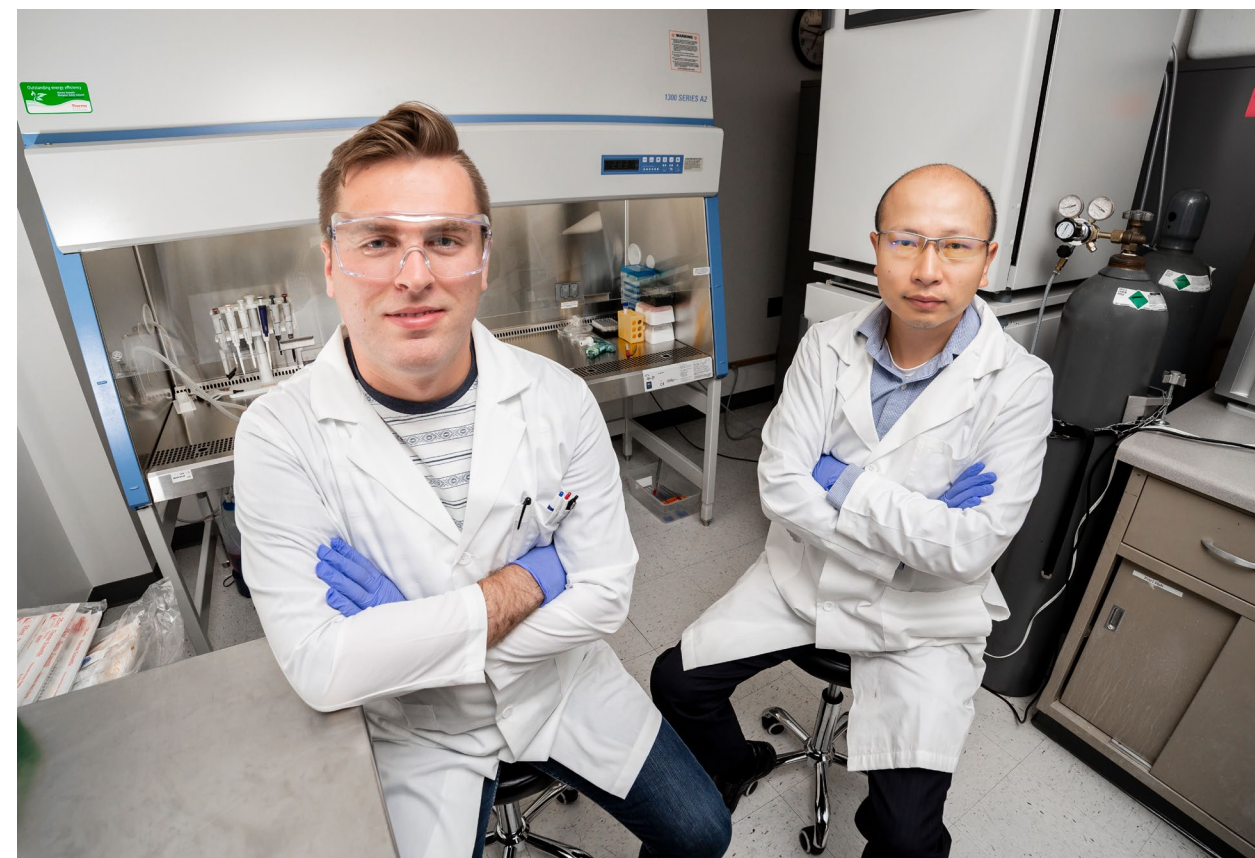

Biological Engineering graduate student Gregory Jensen and assistant professor Yu Huang are developing ways to use engineered materials to screen for new drug therapies.



Photos by Matt Jensen

MAE graduate student Zac Lewis watched the launch from inside NASA's Range Control Center located at Wallops Flight Facility in Virginia.



Professor Stephen Whitmore invented a new environmentally-friendly thruster technology. He led the effort to test the system in space.

NASA Launches USU Student-Built Experiment Into Space

After long delays caused by storms and rough seas, three aerospace engineering graduate students sighed in relief as their payload soared into an early morning sky.

On March 25, students Marc Bulcher, Zac Lewis and Rob Stoddard and aerospace engineering professor Stephen A. Whitmore watched a 43-foot-tall NASA sounding rocket carry their experiment into space. The rocket launched from Wallops Flight Facility on the eastern shore of Virginia. The vehicle flew in space

for approximately seven minutes and reached an altitude of 107 miles before parachuting back to Earth and splashing down in the Atlantic Ocean for recovery.

USU's payload was one of four selected to fly on the rocket. Student teams from the University of Nebraska–Lincoln; the University of Kentucky, Lexington; and the Florida Institute of Technology, Melbourne also had experiments on board as part of NASA's Undergraduate Student Instrument Project.



Left to Right: Graduate student Rob Stoddard, professor Stephen Whitmore, graduate student Marc Bulcher and graduate student Zac Lewis developed and built a green thruster technology package that was flight tested in space.

The goal of the mission was to flight test a new type of thruster developed and patented by Whitmore. Thrusters are small motors used to orient spacecraft in zero gravity. USU's thrusters are made with printed ABS plastic — the same material used to make Legos — and do not burn conventional liquid rocket fuel.

“The vast majority of liquid rocket fuels used for space propulsion are extremely dangerous and toxic,” said Bulcher. “Hydrazine, which is used in satellites and small spacecraft, is carcinogenic, expensive, and presents many safety and environmental challenges.”

To test the new thrusters, the team mounted two of the soda-can sized units to a small test frame inside the large sounding rocket. When the rocket reached the appropriate altitude, its mid-section fell away

and exposed the experiments to the vacuum of space. The test was successful, and each thruster fired five times. Next, the team will determine if exhaust plumes from the thrusters contaminated a nearby optical sensor. If the thrusters burn clean, the technology could revolutionize the space industry.

Such in-flight measurements had never been obtained for this type of thruster system. Whitmore says a rocket of this class had never been started and re-started in a space environment. Until now.

“This is the first time a USA-developed green propellant has been flight tested in space,” said Whitmore. “It’s an exciting time for us because this gives our students unparalleled industry experience, and at the same time we’re developing something that could completely change the small spacecraft industry.” ■

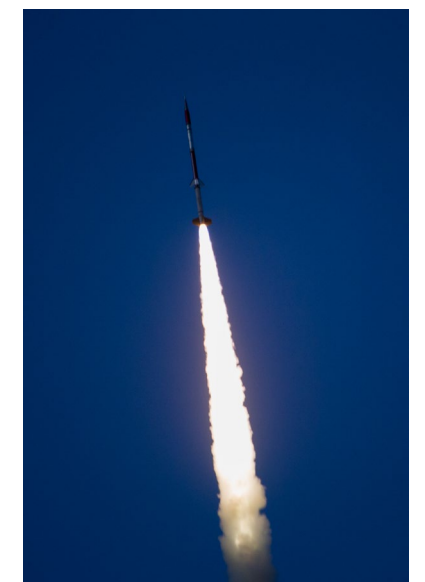

USU's payload hitched a ride on a 43-foot tall NASA sounding rocket. The vehicle flew in space for about seven minutes and allowed researchers to flight test a new thruster technology that could revolutionize the small spacecraft industry. (NASA)

USU Engineering Students Take First at Air Force Design Challenge

United States Air Force officials are taking a close look at a USU student design that may help the planet's growing space junk problem.

A team of undergraduate students in USU's Department of Mechanical Engineering designed and built a device to capture orbital debris. The Human-Assisted Debris Extractor for Space, or HADES, system is designed to capture orbital junk using a pressurized net and drag device. The design earned the 11-member team a first-place win at the Air Force Research Lab University Design Challenge held April 11 at Arnold Air Force Base in Tennessee. The award is the third first-place win for USU.

"We designed the instrument to capture large space debris such as a rocket body," said team lead and recent engineering graduate Russell Babb. "The basic idea is once HADES is in a stable orbit alongside the debris, it launches a net around the body and reels it in. Next, it deploys a drag-inducing parachute that causes the whole

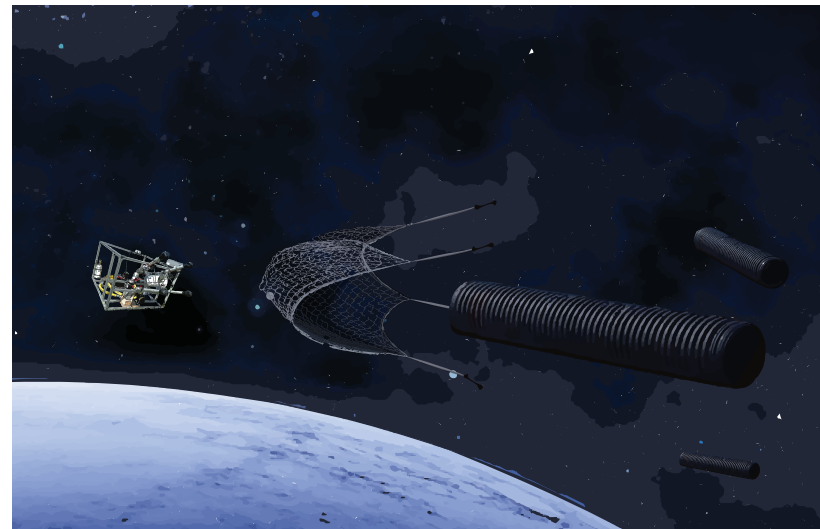

Artist's rendering of the Human-Assisted Debris Extractor for Space, known as HADES. Illustration by Liz Lord.

assembly to deorbit and burn up in the atmosphere."

NASA describes orbital debris as any man-made object orbiting the Earth that no longer has a useful purpose. Traveling at up to 17,500 mph, even the tiniest speck of space junk is a threat to functioning spacecraft. The catastrophic collisions depicted in science fiction films are exaggerated, but experts say the possibility of impact is a very real concern.

"This is something the Air Force takes very seriously," said Mike Lazalier, program manager for the University Design Challenge. Lazalier traveled to Logan to present the students with the award. "Utah State has consistently been in the top. These students in particular are exceptionally professional."

Lazalier said the USU team performed well in all aspects of the design competition in which ten teams from universities around the country vied for best design. He added that the USU team showed exceptional written and verbal communication skills.

"It was obvious they knew everything about the project from every angle," said Lazalier. "It's rare to find young engineers who communicate so effectively."

The top three space debris mitigation designs are now under review by the Air Force.

USU also took first place at the AFRL University Design Challenge in 2012 and 2013, second place in 2014 and third place in 2015. ■

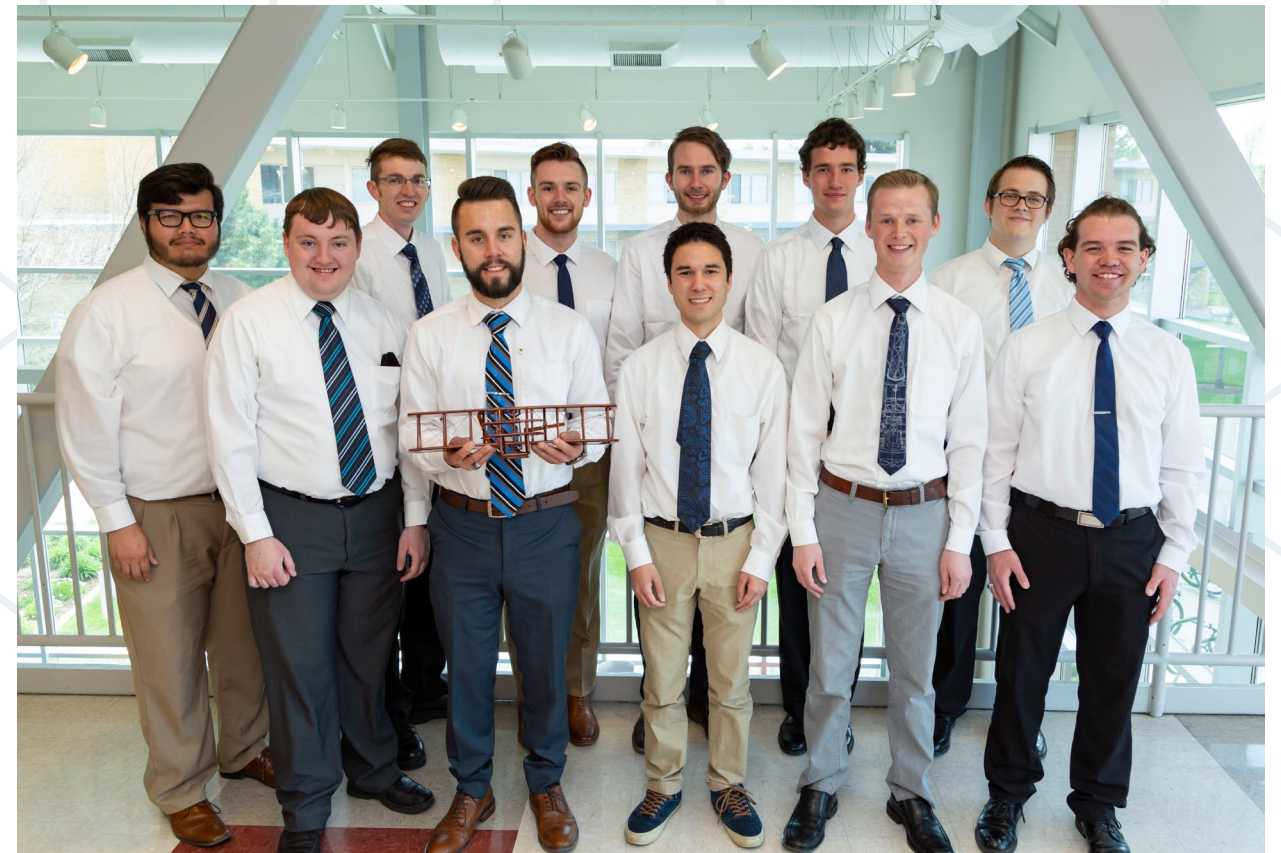

USU students placed first at the 2018 AFRL University Design Challenge for their design of a space debris mitigation apparatus.

2018 Air Force Research Lab University Design Challenge Student Team:

Russell Babb
Bradley Collette
Adam Smith
Mark Findlay
Daniel Prieto
Robert Rowley
Taylor Olpin
Trevor Pratt
Jayden Zundel
Sean Ramirez
Brock Larson

Faculty Advisors

Robert Spall
Jackson Graham
Spencer Wendell

Engineers Without Borders

USU student team continues water quality improvement project in rural Mexico

In Central Mexico, USU engineering students got a real-world lesson about the concepts they study in the classroom. This summer, six student members of Engineers Without Borders traveled to the community of La Salitrera near Mexico City. The team has been traveling to the region since 2009 as part of an ongoing project to mitigate the effects of arsenic-contaminated drinking water.

The team, led by professor Ryan Dupont, taught residents how to build and use inexpensive biosand filters using everyday materials.



USU's EWB team has helped dozens of families in Central Mexico build and effectively use biosand water filters.

“These are extremely humble and hardworking individuals. They’re eager and happy to learn new things and help others in their community. The humble hospitality of these community members is something we can all learn from.”

— Dallin Wiberg, EWB student leader

• What is a Biosand Filter?

Biosand filters are point-of-use water filters typically made of concrete or plastic. The filters contain multiple layers of gravel, fine sand and a layer of biologically active material called the schmutzdecke — a German word meaning ‘dirt cover.’ The layers function together to remove pathogens and suspended solids. By adding a layer of rusty nails, the filter can also reduce arsenic.

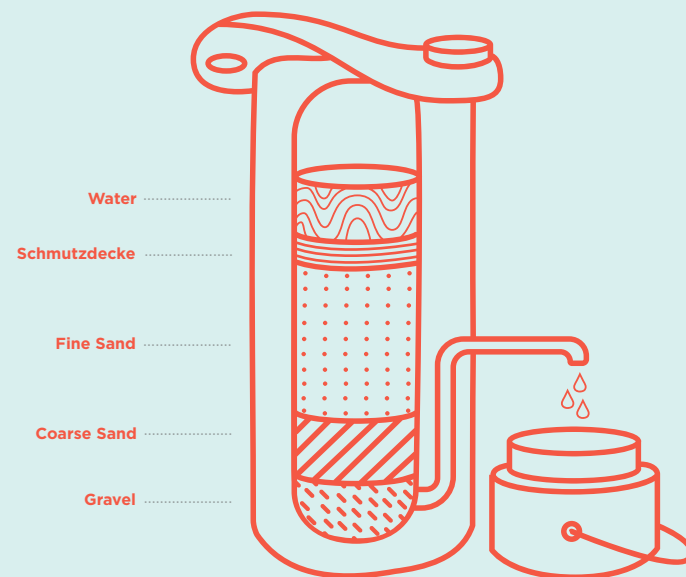

Team Members

Left to right: Students Dallin Wiberg, Megan Licht, Dane Denison, Carolina Collins, Pablo Mendez and Lucy Campos are part of the USU Engineers Without Borders Mexico team.

• The Objective

Part of the mission was to perform a post implementation assessment of previous years’ work.

“We conducted a wide array of water quality tests from an extensive pool of samples from all over the community,” said Wiberg. “We also completed qualitative surveys with families and individuals who use the filters to assess their usage and satisfaction.”

The team evaluated filters that were regularly used and properly maintained and filters that were neglected. “We got drastically different results in the quality of water that comes from a frequently used filter as opposed to one that’s used less.”



A Change of Plans

In the second half of the trip, team members surveyed locations for a proposed water tank designed to service the community. “We collected all the necessary data to come back next year and build the tank at the location desired by the community,” said Wiberg. “When we presented our information to the multi-community water council, we found that their needs had changed.”

The team discovered that members of the community living at higher elevations received less water during certain times of day. When pumps are turned on and water is flowing to the houses, there is usually insufficient water or merely not

enough in the line to create a pressure high enough to reach the residents at higher elevations.

“We were very impressed by their concern for their friends and neighbors,” said Wiberg. “We quickly realized that our project needed to change.”

With the short time remaining, the team gathered the necessary data to create a bypass pipeline that would address the problem. The students helped the community devise a plan that helped ensure water could reach residents living at higher elevations. ■



The USU EWB team has been traveling to Central Mexico since 2009.



Matt Jensen

Assistant professor Angie Minichiello is leading a Navy-funded project to develop a mobile app that teaches young people the basics of fluid dynamics.

Fluid Mechanics: There's an App for That

EED faculty gets major grant to develop engineering education tool

The U.S. Navy recently awarded an \$800,000 grant to a team of Utah State University engineering researchers who are developing a unique educational tool designed to inspire the next generation of naval and ocean engineers.

Angie Minichiello, an assistant professor in the Department of Engineering Education, will lead the project. She and her colleagues are developing a smartphone app that helps young people learn the principles of fluid mechanics. "Understanding fluid mechanics is foundational within the fields of naval and ocean engineering," she said. "Despite their critical importance, fluid mechanics concepts are rarely introduced in U.S. high schools. What's more, undergraduate fluids engineering courses tend to focus — almost exclusively — on mathematical problem solving."

Minichiello and computer science faculty Vladimir Kulyukin and mechanical engineering faculty Tadd Truscott will develop a mobile phone-based version of an optical flow visualization and measurement system called particle image velocimetry, or P-I-V for short. The tool will enable students to learn fluid mechanics concepts and state-of-the-art optical measurement techniques in hands-on, visually stimulating ways. Engineers use PIV to visualize and measure fluid flows in a variety of applications such as air moving over the wing of an aircraft, water flowing through a ship's propulsor or coolant flowing within a nuclear reactor.

"In practice, engineers use PIV to visualize and measure key characteristics of complex flows," said Minichiello. "To do this, engineers first seed the flow with tiny, neutrally-buoyant particles. Next, they illuminate the particles using light from a high power laser while taking multiple digital images of the seeded flow in rapid succession." The images are processed by algorithms that yield pictures of the flow field structures and measurements of critical flow characteristics including velocity, flow rate, shear strain, vorticity and pressure. The results can aid the design of ship hulls, propellers and more. The three-year project kicked off Sept. 1. ■



A New Twist On Archimedes' Screw

Utah Water Research Lab partners with energy company to test hydrodynamic turbine

At the Utah Water Research Lab, engineers are testing a unique water-powered turbine modeled after the ancient technology of Archimedes' screw.

The hydrodynamic turbine was designed and developed by Percheron Power based in Kennewick, Wash., under a cooperative agreement supported by the U.S. Department of Energy. Company principals Jerry Straalsund and Sharon Atkin say this type of hydro turbine has been installed in hundreds of locations in Europe over the past decade, but so far there is only one in the U.S.

READ MORE ►►►



Photos by Matt Jensen

Left to right: Student Taylor Stauffer, professor Michael Johnson, owners Jerry Straalsund and Sharon Atkin and student Trent Balin tested a hydrodynamic screw at the Utah Water Research Lab.

“Percheron and the Utah Water Research Lab team have been jointly planning the test for a while, and it was exciting for all of us to see water flowing through the new turbine and producing power for the very first time,” said Atkin. “We feel fortunate to have a world-class resource like the Water Lab as a partner for testing our turbine.”

The system was installed in a custom test rig inside the Hydraulics Modeling Lab where lead engineer and professor Michael Johnson and his team spent the next few weeks performing tests. The turbine represents the first of its kind to be full-scale tested in the U.S. in a

laboratory environment.

“During testing, we looked at multiple variables to enable Percheron Power to prove their design and demonstrate the viability of their technology,” said Johnson. “It’s exciting to be involved on a prototype test project of this scale and to assist Percheron Power with this turbine design that has such incredible potential. We appreciate that Percheron Power had the confidence in the capabilities of the Utah Water Research Laboratory and its personnel to enter into a contract to complete this project at USU.”

The turbine is made of composite

material instead of steel — a unique difference compared to current industry practice. Atkin says the company developed a new process for producing the turbine’s individual blade segments using an advanced manufacturing method called light resin transfer molding. Straalsund and Atkin say their optimized turbine will result in lower installed costs and improved hydraulic efficiencies compared to existing steel Archimedes-style turbines. The composite turbines are made in the U.S. and will be available to North American customers without the need to import large steel assemblies.



Utah Water Research Lab engineers are testing a hydrodynamic turbine modeled after Archimedes’ screw.

Unlike solar and wind power, hydro-turbines offer round-the-clock energy as long as water is flowing. The company is reviewing existing man-made structures including canals, dams and weirs as potential locations for its hydro turbines. Percheron says the units are rugged and easy to operate and are proven to have very little impact to fish.

“We are very committed to developing cost-effective and environmentally-friendly technologies for distributed power generation,” said Straalsund. “Multiple government and private studies have documented that there are thousands of potential sites for these turbines. Our vision is to offer

modular systems that can be shipped and readily assembled at the hydro-plant site.”

Although the turbine being tested at the Water Lab is considered a prototype, it can produce about 35 KW of power — enough energy to power a ranch or several homes in the U.S.

The system could also be used to provide power to small villages or mills in developing countries. Larger turbines of Percheron Power’s same design can be more than double the diameter and length of the prototype and produce more than 350 KW. Archimedes’ screw turbines can be used as a stand-alone power source or connected to the grid. ■

Hydrodynamic Screw

- **WEIGHT:** 22,000 pounds
- **LENGTH:** 42 feet
- **POWER OUTPUT:** 35 KW
- **DEGREE OF SLOPE:** Variable, 25 degrees (tested)
- **WATER FLOW:** Variable, 10–55 cubic feet per second (tested)
- **SHAFT AND BLADE MATERIALS:** composite
- **TURBINE EFFICIENCY:** 90 percent (average)



Nick Alley, FOUNDER & CEO, AREA-I

BS - '01 Mechanical Engineering
MS - '03 Mechanical Engineering
PHD - '06 Mechanical Engineering
Die-hard Aggie basketball fan

Matt Alexandre

QUICK FACTS: AREA-I

Business Focus: Unmanned Aerial Systems

Known For: Air-Launched, Tube-Integrated, Unmanned Aircraft

Headquarters: Kennesaw (Atlanta-Metro), Georgia

Incorporated: 2009

Number of Employees: 40

Principal Customers: NASA, U.S. Army, Air Force Research Lab, Office of Naval Research

Leading Products

ALTIUS (Air-Launched, Tube-Integrated, Unmanned System)

- Conceived in 2011
- Used for information, surveillance and reconnaissance missions
- Nine-foot wing span
- Stored in and deployed from six-inch diameter tube
- Carries 5-pound payload up to four hours

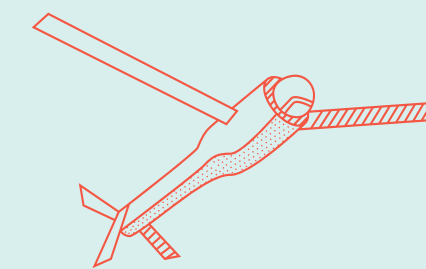

PTERA (Prototype-Technology Evaluation Research Aircraft)

- First Flight in 2012
- Primarily used for aeronautics research
- Eleven-foot wingspan
- Modeled off Boeing's 737
- Used by NASA for researching adaptive wing technologies



Aircraft on Demand

Engineering alumnus pioneers new UAV paradigm

We live in an on-demand society. At the push of a button, we have access to entertainment, technology and information. Now, an aerospace engineer trained at USU is pioneering the next generation of unmanned aerial systems that can be deployed at a moment's notice. The new platform could revolutionize airborne military tactics.

Nick Alley is the CEO and founder of Area-I — a company that's rewriting the textbook on

small unmanned aerial vehicles. The company is just nine years old and already has 40 employees and multi-million dollar contracts with the U.S. Army and NASA, among others.

“I built this company based largely on what I learned at Utah State. I think that says a lot about the education I got at USU.”

“I knew in November 2011 when we got our first air-launched unmanned aerial system contract that it was going to be a big deal,” said Alley from his office in Kennesaw, Ga., about 30 miles northwest of Atlanta.

Growing up in Utah, Alley dreamed of becoming a commercial airline pilot. But after an encounter with a disgruntled airline captain on

a layover, the future engineer had a change of heart.

“Talking with that pilot changed my mind about my career goals,” he recalled. “The turning point was a short time later when I met with my future academic advisor Kathy Bayn. She told me if I went into mechanical and aerospace engineering, I could design airplanes.”

A few years later, the fledgling aerospace engineer was in graduate school working alongside USU's top aerospace faculty including Warren Phillips, Bob Spall, Clair Batty and Frank Redd. Alley became a teaching assistant and advisor on the USU Wright Flyer — a functional replica of the Wright brothers' airplane built in 2003 by USU and the Space Dynamics Lab to commemorate 100 years of aviation. Alley says

his experience in the classroom and aeronautics labs left a lasting impression.

“I loved my education at USU,” he added. “I loved Logan and the friends I made there and the students who I worked with. There was an incredibly talented and experienced group of faculty there. We were always challenged to learn the material and learn it well.”

“It's a hard thing to build a 'flying transformer' that is launched out of a tube, unfolds itself, figures out where it is, and then transitions from that violent launch into steady flight.”

Alley graduated with a Ph.D. from USU in 2006 and worked briefly for Idaho National Laboratory

and later as a research professor at Georgia Tech where he taught flight mechanics. The teaching experience gave him a broader appreciation for USU. “The teaching I saw at Georgia Tech was nothing like what I experienced at USU,” he said. “In Georgia it was more about research and money. At USU it seemed like the faculty cared about teaching. USU was a great environment and a great place to go to school.”

Alley moved to Georgia in 2007 and by 2009 had incorporated his new business. In April of that year the company landed its first big government contract. Today, Area-I is known as a leader in tube-launched unmanned aerial systems. Alley says the tube concept is one of the most effective methods for deploying UAVs on the battlefield or for use in tactical surveillance.

“The tube-launched concept offers UAS on demand,” he said. “The UAV can be stored for long periods of time and then deployed from a manned aircraft. They offer a much-needed supporting role. Before our company came along, there were no good tube-launched aircraft that had any decent amount of endurance. When we started, our nearest competitor could carry a pound or two of payload for 45 minutes. We carry five pounds of payload for up to four hours. We're out-flying multi-billion dollar companies.”

Alley credits part of his success to his USU experience.

“Utah State has the best engineering program in the state,” he added. “I built this company based largely on what I learned at USU. I think that says a lot about the education I got at USU.” ■

Scholarships Make A Difference

McKay Ogden/OGDEN, UTAH
David G. Sant Endowment Scholarship

“The scholarship I received is a way for me to focus on my education and put all my time into practicing engineering. It is an investment in me that I hope to someday pay back.”

Sydney Taylor/BOISE, IDAHO
Engineering Initiative Scholarship and David G. Sant Endowment Scholarship

“The scholarships I received make me feel like I’m a valued student here at USU. They motivate me to be an even better student and to represent USU as best I can.”

Rachael Paskett/LAYTON, UTAH
The Christine Parker Gibson Scholarship

“This scholarship showed me that I was capable of earning an award, which helped me feel more optimistic about continuing in mechanical engineering.”

Stephen Sadler/LOGAN, UTAH
Colonel Lewis A. Civile Scholarship

“I’m a father of two young children, and my wife and I are both students at USU. The scholarship means that we can spend more time with our children rather than working to pay for school.”

Tyler Dudley/TEMECULA, CALIFORNIA
Charles and Rae Perkins Scholarship

“This scholarship meant a lot to me because with the transition from my summer job to my school job, there was a month between paychecks. This scholarship allowed me to fill the gap between paychecks so that my family could stay on track to graduate debt free.”

It Pays to be a Utah State Engineer

305 Scholarships
AWARDED IN 2017

1,294 People Contributed
TO THE COLLEGE OF ENGINEERING IN THE PAST FIVE YEARS

105 College Endowments
PROVIDE FUNDING FOR SCHOLARSHIPS AND STUDENT PROGRAMS

Sant Family Establishes New Professorship for Electrical and Computer Engineering

A new professorship in the College of Engineering honors longtime supporters David G. and Diann L. Sant and empowers a new generation of the most qualified engineering faculty.

College of Engineering Dean Jagath Kaluarachchi announced in August that professor Regan Zane will be the first faculty named to the prestigious new professorship. Zane is a professor of electrical and computer engineering and founder and director of the Center for Sustainable Electrified Transportation, known as SELECT. He brings 20 years of experience in industry and academia with international recognition as a leading expert in power electronics.

The professorship is named for USU benefactors David and Diann Sant. David Sant, a USU alumnus ('62, '64) and veteran electrical engineer, died in 2008 after battling cancer. He is survived by his wife, Diann, who has continued her family’s generous legacy. Since 2008, the Sant family has donated more than \$8 million to USU. They provided major funding for the construction of the Sant Engineering Innovation Building and established endowments that provide perpetual funding for three undergraduate student scholarships. The Sant professorship enables new research efforts and student opportunities under Zane’s leadership.



David G. and Diann L. Sant



Professor Regan Zane was named the inaugural David G. and Diann L. Sant Endowed Professor.

[READ MORE >>>](#)

Professor Regan Zane

\$13 million

In research funding since 2012.

A Passion for Student Success

Mentored 25 undergraduate research students and graduated 14 Ph.D. students who are now leaders in industry, national labs and universities.

At the Center of Innovation

Zane holds 16 patents and has published extensively. He leads multi-million dollar research projects, taking technologies from concept to commercialization.

A Catalyst for Social Impact

He is the founding director of SELECT — a research center focused on sustainable electrified transportation and infrastructure.

Kaluarachchi said Zane’s innovative drive and commitment to student success makes him an ideal beneficiary of the professorship.

“Regan Zane is leading the conversation about sustainable electrified transportation,” said Kaluarachchi. “In a short time, he established one of the most active and visible research centers at the university and secured millions in research funding. He’s making inroads with top industry and government agencies and providing a world-class learning and training experience for our students.”

Industry leaders also praised Zane for his leadership and success.

“Regan Zane has brought the USU SELECT consortium and Power Electronics Research Lab into the complete ecosystem,” said Jae Seung Lee of Toyota Research Institute of North America. “His enthusiasm,

depth of knowledge and strong leadership always leads to constructive outcomes and effective relationship with industry partners.”

Despite his ongoing success and demanding workload, Zane says he remains committed to the success of his students. “It’s an exciting time in our program, especially for students,” he said. “We’ve created a culture of innovation and collaboration where students are motivated by the success of their peers. They’re catching the vision of how their work will advance technology and improve society. Virtually every project we’ve pursued has given students industry exposure and the opportunity to file a patent. The Sant Endowed Professorship will help us achieve new goals and go after new opportunities.” ■

Generous Gift Establishes the Dr. Reid and Evelyn Brown Scholarship Endowment

Reid Brown dreamed about becoming a civil engineer. Thanks to his hard work, support from his spouse and a generous scholarship, he earned bachelor’s and master’s degrees from USU and later earned a PhD from Purdue University.

Brown began his career with the Bureau of Public Roads (Federal Highway Administration) at the early stages of design and construction of the Federal Interstate Highway System. Later, he worked for The Portland Cement Association’s R&D laboratories as a research

engineer where he was instrumental in developing the theoretical mechanisms for D-cracking of Portland cement concrete pavements. His work led to empirical laboratory freeze-thaw aggregate tests that identified potentially deleterious aggregates.

For the next 24 years, Brown worked with Vulcan Materials Company in engineering and management. In 1979, Vulcan assigned him to design and manage a major material supply operation for Saudi Arabia’s Jubail Industrial City



project.

Brown says he established a \$100,000 scholarship endowment to pass on the same benefits he received from his USU education. ■

WHO’S NEW?



Greg Droge
Electrical and Computer Engineering



Brian Crookston
Civil and Environmental Engineering



John Edwards
Computer Science



Mahdi Al-Ameen
Computer Science



Michelle Mekker
Civil and Environmental Engineering



Hailei Wang
Mechanical and Aerospace Engineering



Leonel Mazal
Mechanical and Aerospace Engineering



Randy Christensen
Electrical and Computer Engineering



Joel Ellsworth
Mechanical and Aerospace Engineering



Austin Ball
Civil and Environmental Engineering



Zac Sharp
Civil and Environmental Engineering

WHAT'S NEW?

Idea Factory

The College of Engineering recently debuted its brand new Idea Factory — a state-of-the-art design and fabrication facility for all engineering students. The space includes an array of high-tech equipment, including a laser cutter and engraver, 3-D printers, CNC router and the latest design and engineering software. “The goal of this new lab is to make engineering and prototyping come to life,” said Leo Alfonseca, Idea Factory manager. “We want students to experience what they learn in class in a practical and hands-on way. We want to help bring their innovative ideas to life.”

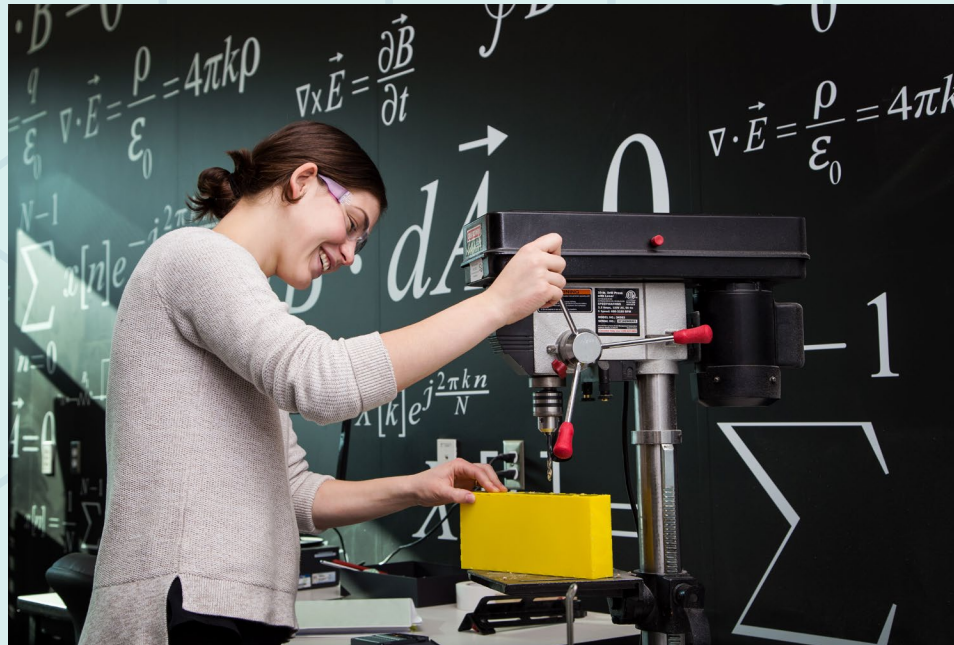

Tutor Center

and Student Support Spaces

The cramped engineering tutor center is a thing of the past. This summer, we renovated a large portion of the Anderson Engineering Building to accommodate a new 915-square-foot tutor center complete with wraparound dry-erase walls, upgraded lighting, computer work stations and new furniture. The remodel was part of a larger renovation of the student support complex. The new space also includes a student break room and new headquarters for student clubs and associations. The student leadership area accommodates eight student organizations, each with its own desk and computer. The facility also has an eight-chair conference room.



QUICK FACTS

The Idea Factory

- **LOCATION:** David G. Sant Engineering Innovation Building
- **PURPOSE:** Open-access student design and fabrication facility
- **SIZE:** 2,750 sq. ft
- **FUN FACT:** The Idea Factory has become so popular, it was doubled in size just nine months after initial completion.

QUICK FACTS

3rd Floor Remodel

- 915-square-foot tutoring center with capacity for eight tutors and 34 students
- 450-square-foot student leadership area and eight-seat conference room
- 435-square-foot meal prep and break area

WHAT'S NEW?

Recirculating Wind Tunnel

This year, the MAE Department acquired a new wind tunnel for use in thermal and fluid dynamics labs. The recirculating-style tunnel was designed and built by Engineering Laboratory Design in Lake City, Minn. It will be used primarily for undergraduate laboratories and demonstrations and some graduate courses.

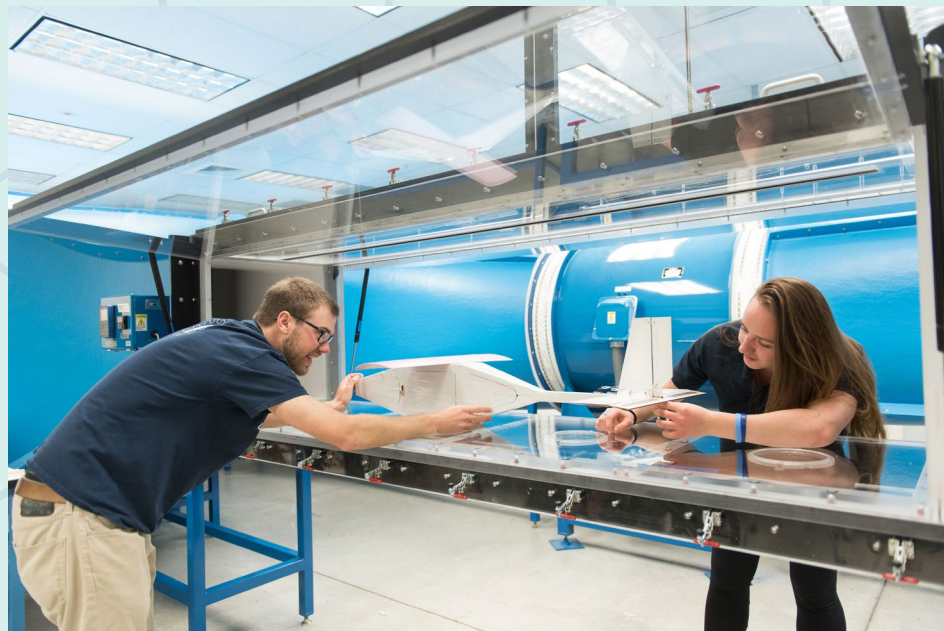

Metal Factory

Today's engineering students need a foundation of technical knowledge and advanced training in design and problem solving. To meet the growing demand of talented professional engineers who are prepared to work in the 21st-century marketplace, we've implemented a brand new design and fabrication facility called the Metal Factory. This modernized space is equipped with the latest fabrication tools and staffed with a veteran engineering technician, Hal Chugg, who will guide student capstone projects from conception to realization.



QUICK FACTS

Wind Tunnel

- **MANUFACTURER:** Engineering Laboratory Design of Lake City, Minnesota
- **ARRANGEMENT:** Recirculating
- **TEST SECTION:** 24"x24"x48" with easy-access, one-piece glass panels
- **VELOCITY RANGE:** Up to 180 fps (122 mph)
- **FUN FACT:** When it runs, it warms the air up. A heat exchanger is used to cool the air back down.
- **MOTOR:** 50 HP
- **FOOTPRINT:** 35'x12'
- **HEIGHT:** 8'

QUICK FACTS

*The Metal Factory
Formerly the
Student Prototyping Lab*

- 7,300-square-foot design and fabrication facility for all engineering students
- Resurfaced concrete floors, new lighting, upgraded entrance, new conference room
- Upgraded equipment including plasma cutter, bandsaws, downdraft table and new welding area

COLLEGE *of*
ENGINEERING
UtahStateUniversity

Utah State University
College of Engineering
Office of the Dean
4100 Old Main Hill
Logan, Utah 84322-4100

NON-PROFIT ORG
U.S. Postage Paid
Utah State University

Need for Speed?

USU is home to the nation's first test track for electrified transportation research. The Electric Vehicle & Roadway Research Facility and Test Track is a state-of-the-art complex at the forefront of wirelessly-charged electric vehicle and roadway technologies.

