

## SUSTAINABLE AGRICULTURE TECHNIQUES

---

EM 8912 • Revised January 2013

---

# Drip Irrigation Guide for Potatoes

*C.C. Shock, F. Wang, R. Flock, E. Eldredge,  
A. Pereira, and J. Klauzer*

---



Malheur Experiment Station, Oregon State University: *Clint C. Shock, director and professor; Rebecca Flock, former research aide; Eric Eldredge, faculty research assistant; Andre Pereira, visiting professor (associate professor, Department of Soil Science and Agricultural Engineering, UEPG, Parana, Brazil).*

Center for Agricultural Water Research in China, China Agricultural University, Beijing: *Feng-Xin Wang, associate professor*

Clearwater Supply, Ontario, OR: *Jim Klauzer*

Oregon State University Malheur Experiment Station at Ontario, Oregon, has evaluated drip irrigation on potato. We have investigated crop response to drip tape flow rate, bed conformation, drip tape placement with respect to potato rows, microirrigation criteria, and potato plant population.

When compared to furrow irrigation, drip irrigation of potato reduces water use, nitrate leaching, erosion, and deep percolation, while increasing marketable yield. Drip irrigation of potato uses less water than sprinkler irrigation for comparable yield.

Drip systems should be designed for each crop and field. Growers have many options for custom fitting a drip system to their specific situation. It is difficult to describe in a brief publication all of the factors that affect irrigation. Thus, this publication provides a framework, general recommendations, and rationales to aid potato growers interested in maximizing their land use and crop yield through drip irrigation. Consult your local Extension agent or other agricultural professional for additional information.

### Initial interest

In 1984 and 1985, the potato industry in the Pacific Northwest faced a crisis. Potato tuber quality was inadequate to meet the needs of potato processing companies. A condition called “sugar ends” or “dark ends” was common in fried slices of tubers grown on stressed plants, but the stresses aggravating the condition were poorly defined. Growers lost contracted acres.

In 1989, northern Malheur County was declared a groundwater management area due to groundwater nitrate contamination. The groundwater contamination was linked, at least in part, to furrow irrigation.

In arid regions, all irrigation systems require some leaching fraction to avoid salt accumulation. However, the high nitrogen (N) fertilizer rates used through the 1980s, combined with heavy water applications by furrow irrigation, allowed nitrate and other mobile compounds to be readily lost to deep percolation. Irrigation-induced soil erosion was also a problem.

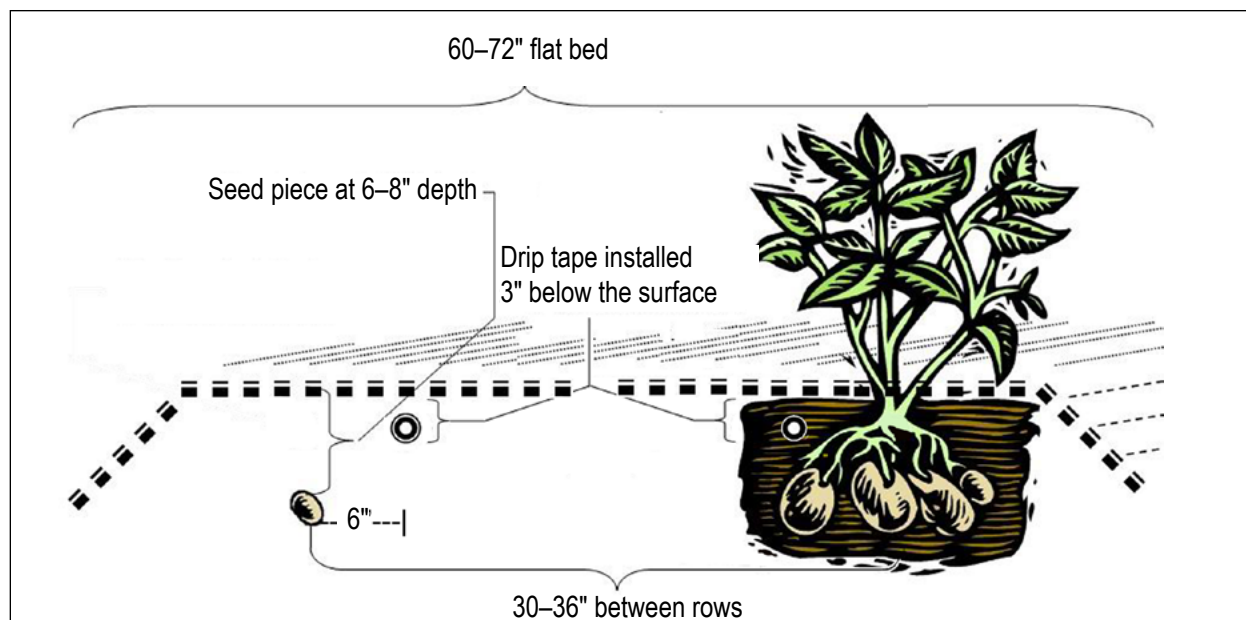

Figure 1. Cross section of a drip-irrigated, flat-topped bed in which the drip tapes are placed offset above the plant rows.

In an effort to find an alternative method of irrigating crops with high water demand in an arid region, both sprinkler and drip irrigation were considered.

This guide discusses drip irrigation. Drip irrigation is the slow, even application of low-pressure water to soil and plants using plastic tubing, called drip tape, placed directly in the plants' root zone. Emitters are evenly spaced along the tape's length to allow the water to drip into the crop root zone. This method allows for very little evaporation and zero runoff, saves water by directing it more precisely, reduces the transmission of pathogens, and wets less of the soil surface, thus producing fewer weeds.

### Site selection

When designing a drip system, first identify irrigation zones. Irrigation zones are based on factors such as topography, field length, soil texture, optimal tape run length, and filter capacity. A drip system supplier will have design software that takes these factors into consideration. Once the zones are identified and the drip system

designed, it is possible to schedule irrigations to meet the unique needs of each zone.

### Bed conformations

The traditional bed conformation for potato is a hilled row. This design is common throughout England, Ireland, and Wales, where furrows are used both to irrigate crops and to drain off water in these high rainfall environments.

The Malheur Experiment Station carried out experiments with bed conformation that may be more suited to the arid climate of the Treasure Valley and may provide a cooler environment for tuber growth. One of the simplest bed conformations that had a high yield of U.S. No. 1 grade is two rows of potatoes 36 inches apart on a 72-inch flat bed. Two drip tapes are used; each is placed offset above a row of seed pieces (Figure 1). When potato seeds are planted directly in line with the drip tape, the tubers are in the best irrigated part of the soil, but may pinch off the drip tape as they grow.

In preliminary trials, this conformation outperformed sprinkler-irrigated potato on

conventional beds. However, conventional 36-inch hilled rows equipped with subsurface drip tapes directly above the seed piece did not fare as well as potatoes in sprinkler-irrigated hills.

### **Plant population for drip irrigation**

Research at the Malheur Experiment Station showed no significant economic advantage to increasing plant population per acre. The standard planting rate (18,150 seed/acre) was compared to a rate increased by 30 percent (24,200 seed/acre). The additional seed did not increase the percentage of U.S. No. 1 tubers harvested per acre, but did increase the percentage of undersized tubers (Shock et al., 2005b).

### **Stress-resistant varieties**

Several varieties and numbered clones have been identified as genotypes that express fewer tuber defects than Russet Burbank when subjected to stress. These varieties may be further distinguished by their response to irrigation method. For example, the varieties Ranger Russet and Umatilla Russet produce nearly equal yields under sprinkler irrigation. Nevertheless, Ranger Russet has outperformed Umatilla Russet under drip irrigation.

When Ranger Russet is grown on flat beds with a single drip tape for each row of plants, marketable yield is higher than on comparable sprinkler-irrigated conventional beds (Shock et al., 2005a).

### **Pumps and filters**

An ineffective or improperly managed filter station can waste a lot of water and threaten a drip system's fitness and accuracy.

In the western U.S., sand media filters have been used extensively for drip irrigation systems. Screen filters and disk filters are common alternatives, or are used in combination with sand media filters.

Sand media filters provide filtration to 140 to 200 mesh, which is necessary to clean water from

open canals for drip irrigation. These water sources pick up fine grit and organic material, which must be removed before the water passes through the drip tape emitters (Figure 2, page 4).

Sand media filters are designed to be self-cleaning through a "back flush" mechanism. This mechanism detects an increase in the pressure differential between input and output of the filter due to the accumulation of filtered particles. It then flushes water back through the sand to dispose of clay, silt, and organic particles. Some back flush mechanisms are based on elapsed time rather than on pressure differential.

Sand used for filters should be between size 16 and 20 to prevent excessive back flushing. It may be better to use several smaller sand media filters rather than a few larger tanks so that clean water is available for the flush.

In addition to a sand media filter, a screen filter can be used as a prefilter to remove larger organic debris before it reaches the sand media filter, or as a secondary filter before the irrigation water enters the drip tape. For best results, screens should filter out particles four times smaller than the emitter opening, as particles may clump together and clog the emitters. Secondary screen filters often are omitted if the drip tape is replaced annually.

Screen filters can act as a safeguard if a problem occurs with the main filters. They also may act as the main filter if a sufficiently clean underground water source is used. However, some groundwater contains enough particulate matter to require a sand media filter.

### **System maintenance**

#### ***Flow meter***

A water flow meter should be an integral part of the system, and each zone's total flow should be recorded regularly. This provides a clear indication of how much water was applied to each zone. Water flow records can be used to detect deviations from the standard flow, which

may be caused by leaks in the system or by clogged lines.

### **Watch for leaks**

Leaks can occur unexpectedly as a result of damage by insects, animals, hand weeding, or cultivation tools. Systematically monitor the lines for damage. It is important to fix holes as soon as possible in order to maintain system uniformity. Some insect damage to the drip tape can be avoided through preventive insecticide applications or by running the irrigation system as soon as the drip tape is installed.

### **Chlorine clears clogged emitters**

If the rate of water flow progressively declines during the season, the tape may be slowly

plugging, resulting in severe damage to the crop. In addition to maintaining the filter stations, flush the drip lines once a month by opening a portion of the tape at a time and allowing the higher velocity water to wash out the sediment.

The application of chlorine through the drip tape will help minimize clogging. In the northern U.S., because algae growth and biological activity in the tape are especially high during June, July, and August, chlorine usually is applied at 2-week intervals during these months.

If drip lines become plugged in spite of maintenance, a cleaning product may be available through irrigation system suppliers. Choose a product appropriate for the specific cause of the clogging.

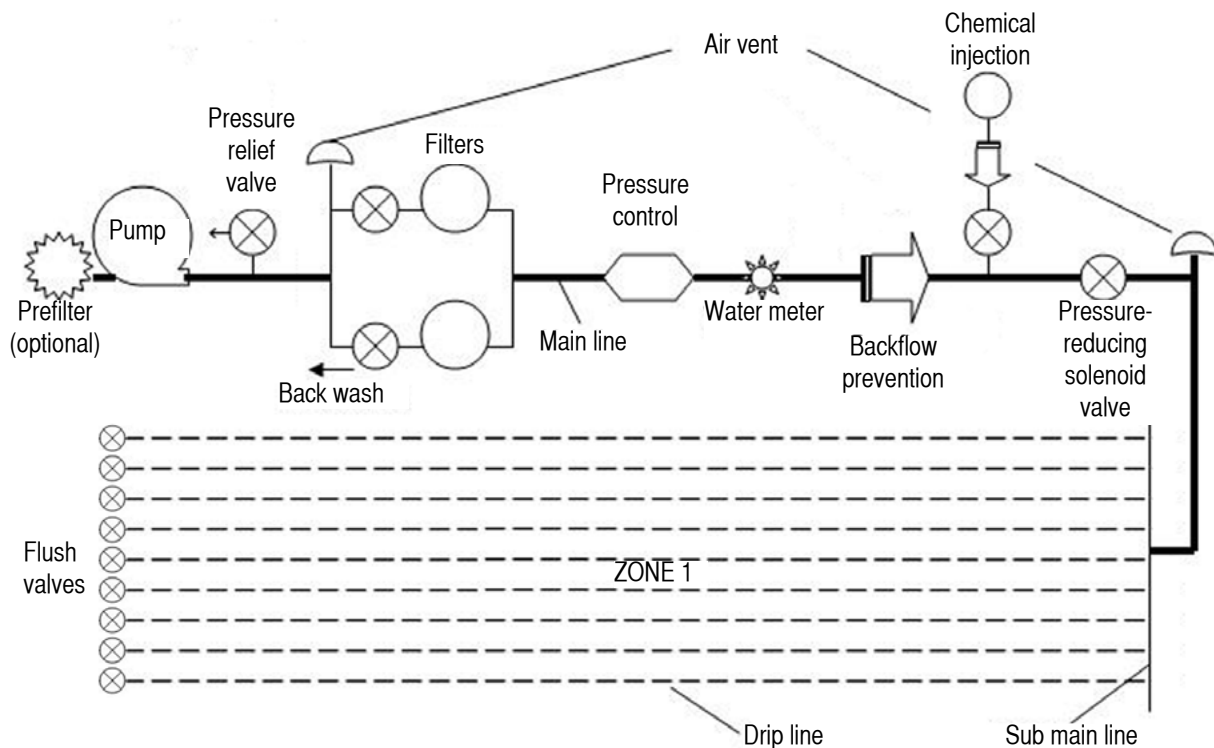

*Figure 2. Drip irrigation system with a prefilter, pump station with backflow prevention, and chemical injection site. A pressure control valve is recommended to adjust the water pressure as desired before it enters the drip lines. A water meter can be placed after the pressure control or between a solenoid valve and each zone. An air vent provides vacuum relief. Vacuum relief is necessary between the solenoid valve and the drip tapes to avoid suction of soil into the emitters when the system is shut off.*

## Microirrigation criteria

### *Daily crop water use*

Irrigation application must reflect crop water use. Therefore, it is crucial to plan how much water to apply and when to apply it to optimize potato crop performance.

One aim of irrigation is to replace the daily crop evapotranspiration. Estimated daily potato evapotranspiration for the western Treasure Valley is available on the Malheur Experiment Station's website ([www.cropinfo.net](http://www.cropinfo.net)). Drip-irrigated potato may require less water than evapotranspiration estimates for sprinkler-irrigated potato (Shock et al. 2002, 2005b).

Water applied at any one irrigation should not exceed the soil's water-holding capacity. Different combinations of duration, frequency, and flow rates can be customized to meet varying irrigation needs within a field.

### *Getting started*

During each irrigation, the wetting pattern needs to effectively rewet the root zone. The first irrigation of the season establishes the wetting pattern and can be longer than subsequent irrigations. Initial irrigations are commonly 24 hours, or 48 hours in dry years. Fine particles or salts in the soil can be moved laterally with the initial wetting front, and they stop moving when the water ceases to move outward. Expanding a wetting pattern beyond this initial boundary can require an excessive amount of water. Once growers monitor for the desired wetting pattern during the initial irrigation, subsequent irrigation sets should maintain the previously established wetting pattern.

### *Emitter flow rate*

The drip tape emitters determine the flow rate of water into the root zone. Drip tapes with lower water application rates make low-intensity, high-frequency irrigations more feasible by improving wetting pattern and uniformity. Low flow (0.13 gal per hour per emitter) and ultra-low flow (0.066 gal per hour per emitter) are two of the

emitter options commercially available for silt loam. There was no difference in potato production between low-flow and ultra-low-flow tapes on silt loam (Akin et al., 2003).

### *Frequency*

Growers can expect to irrigate drip fields more frequently than furrow-irrigated fields. One reason for the need for more frequent irrigation is simply that less water is applied per irrigation. Also, moisture may be wicked away from the root zone as the irrigated soil and surrounding dry soil equilibrate.

Drip irrigation permits greater control and precision of irrigation timing and the amount of water applied. This flexibility to manage a schedule based on root zone soil water tension (SWT), thus precisely matching crop needs, may be the greatest advantage of drip irrigation. Automated irrigation cycling between drip zones can aid in providing the right amount of water to each zone.

### *Why measure soil water tension?*

SWT is economically and environmentally important because it is the measure of how strongly water is held in the soil. Potatoes have a relatively shallow root system and little tolerance for water stress or irrigation errors. Tuber yield and grade are related to the amount of energy needed for the roots to remove water from the soil. Viewed in graphical form, the SWT clearly indicates the relative condition of the root zone of the crop over time.

The use of granular matrix sensors and tensiometers to determine crop water needs is discussed in *Irrigation Monitoring Using Soil Water Tension*, EM 8900 (Shock et al., revised 2013b). These principles are applied to potato in *Successful Potato Irrigation Scheduling*, EM 8911 (Shock et al., revised 2013c).

Potato is a water-stress-sensitive crop. Potato plants are more productive and produce higher quality tubers when watered precisely using SWT than if they are under- or overirrigated. Tuber

market grade, specific gravity, and French fry processing quality are all negatively affected by excessive water stress during tuber bulking. Conversely, oversaturating the soil reduces aeration of the root zone and may result in increased potato decay in storage.

### **Recommended SWT**

For drip-irrigated potatoes on silt loam, tuber growth and grade are maximized if plants are irrigated when SWT at the 8-inch depth reaches 30 centibars (cb) (Shock et al., 2005a). Note that lower numbers indicate wetter soil (0 cb = saturated; 100 cb = dry). This recommendation is based on several factors.

After tuber initiation, even small amounts of water stress can result in decreased tuber grade, decreased specific gravity, or increased incidence of dark-end fry colors. Delaying drip irrigation until the soil dries to 45 cb has been shown to reduce tuber yield and grade (Shock et al., 2002). With sprinkler irrigation, a single episode of water stress (SWT drier than 60 cb on silt loam) can reduce tuber grade and specific gravity and increase the occurrence of dark-ends at harvest. Overly dry soil, especially during the early stages of tuber development, also favors common scab (*Streptomyces scabies*). Average readings at the 8-inch depth must remain below 60 cb in order to avoid permanent damage to developing potato tubers.

Irrigation at 15 cb on silt loam results in excessive use of water and swollen lenticels. Yield reductions due to overirrigation can be attributed to poor soil aeration, increased susceptibility to rots and diseases, and leaching of N from the shallow root zone.

### **Chemigation**

Irrigation and fertilization should be managed together to optimize efficiency. Chemigation through drip systems efficiently deposits chemicals in the root zone of the receiving plants (Schwankl and Prichard, 2001). Because of its

precision of application, chemigation can be safer and use less material than spray applications. Several commercial fertilizers and pesticides are labeled for delivery by drip irrigation.

Injection pumps with backflow prevention devices are necessary to deliver the product through the drip lines. These pumps allow for suitable delivery rate control. Backflow prevention protects both equipment and the water supply from contamination. Other safety equipment may be required; contact a drip-irrigation system supplier for details.

### **Nitrogen fertilizers**

Soil microorganisms convert N fertilizers to nitrate. Nitrate is water soluble, available to plants, and subject to leaching loss. Since nitrate loss management was one of the initial reasons for exploring drip irrigation in the Treasure Valley, it is appropriate that we revisit this topic.

Research conducted at Malheur Experiment Station showed that high-quality tubers can be produced with far lower inputs of N fertilizer (100 to 180 lb N/acre) than growers had used in the past (300 to 400 lb N/acre). Optimum yield responses have even been obtained with rates ranging from 120 lb N/acre to no additional N following alfalfa. If excess irrigation is avoided, N rates over 120 lb N/acre are rarely economically beneficial.

Principles of N fertilization for drip-irrigated potato in silt loam soil in the Treasure Valley include the following.

- Nitrogen fertilizer application is needed only when potatoes have the greatest opportunity to absorb N (between plant emergence and midseason tuber bulking). Nitrogen may be applied efficiently via the drip system at this time.
- Careful irrigation management produces little to no nitrate leaching. In silt loam soils, it also can reduce N fertilization requirements.
- Potatoes with the lowest fertilizer application rates have the highest tuber specific gravity,

providing an additional advantage to moderate N application.

- The best way to determine N fertilizer needs is through regular petiole sampling.

### **Pest management**

Proper irrigation scheduling also affects pest management strategies. Soil water decreases the mobility of cutworms and potato tuber moth, protecting the tubers from attack.

Systemic insecticides sometimes are used in drip systems for enhanced insect and nematode control. Normally, the product is introduced during the middle of the irrigation set, allowing a clean water period to push the product out of the drip tape and closer to the crop.

Alkaline irrigation water decreases the effectiveness of some insecticides. Consequently, acid sometimes is needed to reduce the pH of the water. A second injection pump is needed for the acid.

### **Irrigation and disease**

Excessively wet soil is conducive to many tuber-rotting pathogens, and excessive moisture on the crop canopy encourages the incidence of foliar blights and wilts that can limit potato performance. Drip irrigation can be managed to provide adequate water without creating excess moisture, thus potentially requiring fewer fungicide applications.

Shallow-set tubers exposed by erosion in sprinkler- and furrow-irrigated fields are subject to greening or sun scald and are more susceptible to early and late blight pathogens. Drip irrigation is an effective way to prevent tuber exposure since water application is more gentle.

### **For more information**

Akin, A., L. Unlenen, E.P. Eldredge, C.C. Shock, E.B.G. Feibert, and L.D. Saunders. 2003. Processing potato production with low-flow drip tape or ultra-low-flow tape. Oregon State University Agricultural Experiment

Station Special Report 1048:167–172. Available online at <http://www.cropinfo.net/AnnualReports/2002PotatoDripFlowAnRep2002.php>

Burt, C.M. and S.W. Styles. 2011. *Drip and Micro Irrigation Design and Management for Trees, Vines, and Field Crops*. Cal Poly, San Luis Obispo, CA.

Eldredge, E.P., C.C. Shock, and L.D. Saunders. 2003. Early and late harvest potato cultivar response to drip irrigation. *Acta Hort.* 619:233–239.

Lamm, F.R., J.E. Ayars, and F.S. Nakayama (eds.). 2007. *Microirrigation for Crop Production—Design, Operation and Management*. Elsevier Publications. <http://www.elsevier.com/books/microirrigation-for-crop-production/lamm/978-0-444-50607-8>

Schwankl, L.J. and T. Prichard. 2001. *Chemigation in Tree and Vine Microirrigation Systems*. Agriculture and Natural Resources Publication 21599, University of California, Davis, CA.

Schwankl, L.J. 2013. Maintenance of Micro-irrigation Systems (website). <http://ucanr.org/sites/Microirrigation>

Shock, C.C., E.P. Eldredge, and L.D. Saunders. 2002. Drip irrigation management factors for ‘Umatilla Russet’ potato production. Oregon State University Agricultural Experiment Station Special Report 1038:157–169. Available at <http://www.cropinfo.net/AnnualReports/2001/01DripFacto.php>

Shock, C.C., E.P. Eldredge, and A.B. Pereira. 2005a. Irrigation system comparison for the production of ‘Ranger Russet’ and ‘Umatilla Russet’ potato. Oregon State University Agricultural Experiment Station Special Report 1062:173–176. Available online at <http://www.cropinfo.net/AnnualReports/2004/ranger%20umatilla%20compare04.php>

- Shock, C.C., E.P. Eldredge, and A.B. Pereira. 2005b. Planting configuration and plant population effects on drip-irrigated 'Umatilla Russet' potato yield and grade. Oregon State University Agricultural Experiment Station Special Report 1062:156–165. Available online at <http://www.cropinfo.net/AnnualReports/2004/plant%20config%20&%20poplulation%20effects04.php>
- Shock, C.C., E.P. Eldredge, and L.D. Saunders. 2005c. Tuber bulking rate and processing quality of early potato selections. Oregon State University Agricultural Experiment Station Special Report 1062:141–155. Available online at <http://www.cropinfo.net/AnnualReports/2004/Tuber%20bulk04.php>
- Shock, C.C. and F.X. Wang. 2011. Soil water tension, a powerful measurement for productivity and stewardship. *HortScience* 46: 178–185.
- Shock, C.C. Revised 2013a. *Drip Irrigation: An Introduction*. Oregon State University Extension publication EM 8782. Available online at <http://ir.library.oregonstate.edu/xmlui/bitstream/handle/1957/20206/em8782-e.pdf>
- Shock, C.C., F.X. Wang, R.J. Flock, E.B.G. Feibert, C.A. Shock, and A.B. Pereira. Revised 2013b. *Irrigation Monitoring Using Soil Water Tension*. Oregon State University Extension publication EM 8900. Available online at <http://ir.library.oregonstate.edu/xmlui/bitstream/handle/1957/20424/em8900.pdf>
- Shock, C.C., F.X. Wang, R.J. Flock, E.P. Eldredge, and A.B. Pereira. Revised 2013c. Successful Potato Irrigation Scheduling. Oregon State University Extension Service publication EM 8911. Available online at <http://ir.library.oregonstate.edu/xmlui/bitstream/handle/1957/43731/em8911.pdf>

### Acknowledgments

Funding to help prepare this publication was provided by an Oregon Watershed Enhancement Board grant.

### Quick Facts

- Drip irrigation is the slow, even application of low-pressure water to soil and plants using plastic tubing placed directly in the plants' root zone.
- Drip irrigation systems facilitate water management in fields that are difficult to irrigate due to variable soil structure or topography.
- Potato yield and grade respond very sensitively to irrigation management.
- For drip-irrigated potato grown on silt loam, recommended soil water tension for irrigation onset is 30 centibars.
- Seasonal water needs for drip-irrigated potato are 16 to 24 inches at Ontario, OR, depending on the year.
- Drip systems require careful design and maintenance.

© 2013 Oregon State University.

Extension work is a cooperative program of Oregon State University, the U.S. Department of Agriculture, and Oregon counties. Oregon State University Extension Service offers educational programs, activities, and materials without discrimination based on age, color, disability, gender identity or expression, genetic information, marital status, national origin, race, religion, sex, sexual orientation, or veteran's status. Oregon State University Extension Service is an Equal Opportunity Employer.

Published October 2006. Revised January 2013.