

## SUSTAINABLE AGRICULTURE TECHNIQUES

---

EM 8901 • Revised January 2013

---

# Drip Irrigation Guide for Onion Growers

*C.C. Shock, R. Flock, E. Feibert,  
C.A. Shock, and J. Klauzer*

---



---

Malheur Experiment Station, Oregon State University:  
*Clint C. Shock, director and professor; Rebecca Flock,  
former research aide; Erik Feibert, senior faculty  
research assistant; Cedric A. Shock, former research  
aide*

Clearwater Supply, Ontario, Oregon: *Jim Klauzer*

**Oregon State** | **Extension**  
UNIVERSITY | **Service**

Since 1992, the Oregon State University Malheur Agricultural Experiment Station in Ontario, Oregon, has evaluated drip irrigation on onion. As pioneers in onion drip irrigation, we have investigated crop response to irrigation intensity and flow rate, bed configuration, subsurface chemigation, nitrogen fertilizer rates, microirrigation criteria, and plant population. As a result of this research, distinct advantages of drip irrigation have become available to growers. These advantages include lower fertilizer costs; significant reductions in water use and nitrate leaching; increased control of insects, iris yellow spot virus, and weeds; and increased onion size and marketable yield. Drip irrigation is expected to exceed 50 percent of Treasure Valley onion crop acres in 2013.

Drip systems are tailored to each crop and field. Growers have many options for custom fitting a drip system to their specific situation. It is difficult to describe in a brief publication all of the factors that affect irrigation. Thus, this publication provides a framework, general recommendations, and rationales to aid onion growers interested in maximizing their land use and crop yield through drip irrigation. Consult your local extension agent or other agricultural professional for additional information.

### Initial interest

In 1989, northern Malheur County was declared a groundwater management area due to groundwater nitrate contamination. The groundwater contamination was linked, at least in part, to furrow irrigation of onion.

In arid regions, all irrigation systems require some leaching fraction to avoid salt accumulation. However, the high nitrogen fertilizer rates used through the 1980s, combined with heavy water applications to furrow-irrigated onion, allowed nitrate and other mobile compounds to be lost readily to deep percolation. Surface erosion also posed a problem.

In an effort to find an alternative method of irrigating crops with high water demands in an

arid region, we considered drip irrigation. Drip irrigation is the slow, even application of low-pressure water to soil and plants using plastic tubing placed directly at the plants' root zone.

This method allows very little evaporation or runoff, saves water by directing it more precisely, reduces the transmission of pathogens, and produces fewer weeds.

### Site selection

High onion yields are feasible with furrow irrigation on level, even-textured fields without investment in drip irrigation. However, variable topography or soil textures make furrow or sprinkler irrigation difficult. Drip irrigation can irrigate these difficult fields uniformly, thus maximizing land use and crop yield.

When designing a drip system, first identify fairly similar *irrigation zones*. Irrigation zones are based on factors such as topography, field length, soil texture, optimal tape run length, and filter capacity. Many irrigation system suppliers use computer programs to easily analyze these factors and design drip systems. Once the zones are assigned and the drip system designed, it is possible to schedule irrigations to meet the unique needs of each zone.

### Drip system uniformity

Because onions have very strong positive yield and grade responses to wet soil, yet exhibit increased risk of decomposition in overly wet soil, it is indispensable that the drip system be carefully designed to apply water uniformly. Yield is lost in excessively dry areas, while disease and nitrate leaching are promoted in excessively wet areas. The minimum water application uniformity for onion is 90 percent.

### Bed configuration

The bed configuration used in many of our studies has proven effective for Sweet Spanish onion. Two double rows per 34- to 44-inch bed

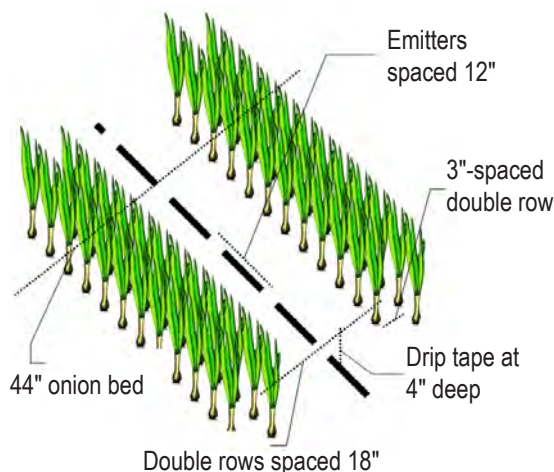

*Figure 1. Typical bed configuration for drip-irrigated onions. On 44-inch beds, two double rows are centered 18 inches apart. Double rows consist of two onion rows spaced 3 inches apart. Drip tapes are installed 3 to 4 inches deep in the bed center. Tape emitters are 12 inches apart.*

are planted in late March at 150,000 seeds/acre. The 44 inches is the distance between the furrows. Double rows are centered 18 inches apart and consist of two onion rows spaced 3 inches apart (Figure 1).

Drip tapes are installed 2 to 3 inches deep in the bed center, between the two double rows, at the time of planting. The tape emitters are spaced 8 to 12 inches apart.

This bed configuration minimizes tape use and cost per acre. However, this configuration can be problematic if the water fails to “sub” or move over to the onion rows. Alternative bed configurations have been used successfully, especially in soils where the water will not wick to the side sufficiently for one tape to serve a conventional bed. The use of three drip tapes with six double rows of onions on 78- to 88-inch beds is locally called “intense bed.” One double row is planted on either side of each tape so that the onion rows are closer to the drip tapes.

### ***Plant population***

Closely related to bed configuration is the issue of plant spacing and population. Over the past few decades, the advent of larger market size classes—colossal (4 to 4½ inches) and super colossal (larger than 4½ inches)—has led to new considerations in plant population and spacing.

Because the entire top of the onion bed is wetted under drip irrigation, growers initially assumed that more onions could be planted per acre by spacing them closer together. This approach succeeds in increasing the total number of onions, but the crowded spacing can result in a greater number of smaller, lower value onions. To optimize financial returns, one must consider the influence of plant population on bulb size.

Research at the Malheur Experiment Station showed that onion bulb size distribution is closely related to plant population (Shock et al., 2004). Colossal and super colossal onion yields are favored by low plant population and less plant competition. In our research, comparatively higher populations resulted in greater numbers of medium and jumbo onions, as well as greater total marketable onion yield.

### ***Finding the balance***

It is difficult to predict the optimum onion plant population in any year due to price variability. Onion prices vary by size class depending on availability, which depends on weather in several production areas. Onion prices can increase with increasing bulb size. However, when the market does not favor super colossal and colossal onions, gross returns are correlated more with total marketable yield.

### ***Pumps and filters***

Every trickle counts when you are battling a water shortage. An ineffective or improperly managed filter station can waste a lot of water and threaten a drip system's fitness and accuracy.

In the West, sand media filters are used extensively for drip irrigation systems. Screen filters and disk filters are common alternatives or for use in combination with these filters.

Sand media filters provide filtration to 200 mesh, which is necessary to clean surface water and water from open canals for drip irrigation. These water sources pick up a lot of fine grit and organic material, which must be removed before the water passes through the drip tape emitters (Figure 2, page 4).

Sand media filters are designed to be self-cleaning through a “back flush” mechanism. This mechanism detects an increase in the pressure differential between input and output of the filter due to the accumulation of filtered particles. It then flushes water back through the sand to remove clay, silt, and organic particles. Some back flush mechanisms are based on elapsed time or a combination of elapsed time and pressure differential, rather than on pressure differential alone.

Sand used for filters should be between size 16 and 20 to prevent excessive back flushing. It may be better to use several smaller sand media filters rather than a few larger tanks so that clean water is available for the flush (Gelski, 2003). Sand media needs to be replaced every two or three seasons.

In addition to a sand media filter, a screen filter can be used as a prefilter to remove larger organic debris before it reaches the sand media filter, or as a secondary filter before the irrigation water enters the drip tape. For best results, screens should filter out particles four times smaller than the emitter opening, as particles may clump together and clog emitters.

Screen filters can act as a safeguard if a problem occurs with the main filters. They also may act as the main filter if a sufficiently clean underground water source is used. However, some groundwater contains enough particulate matter to require a sand media filter.

Secondary filters often are omitted if the drip tape is replaced annually.

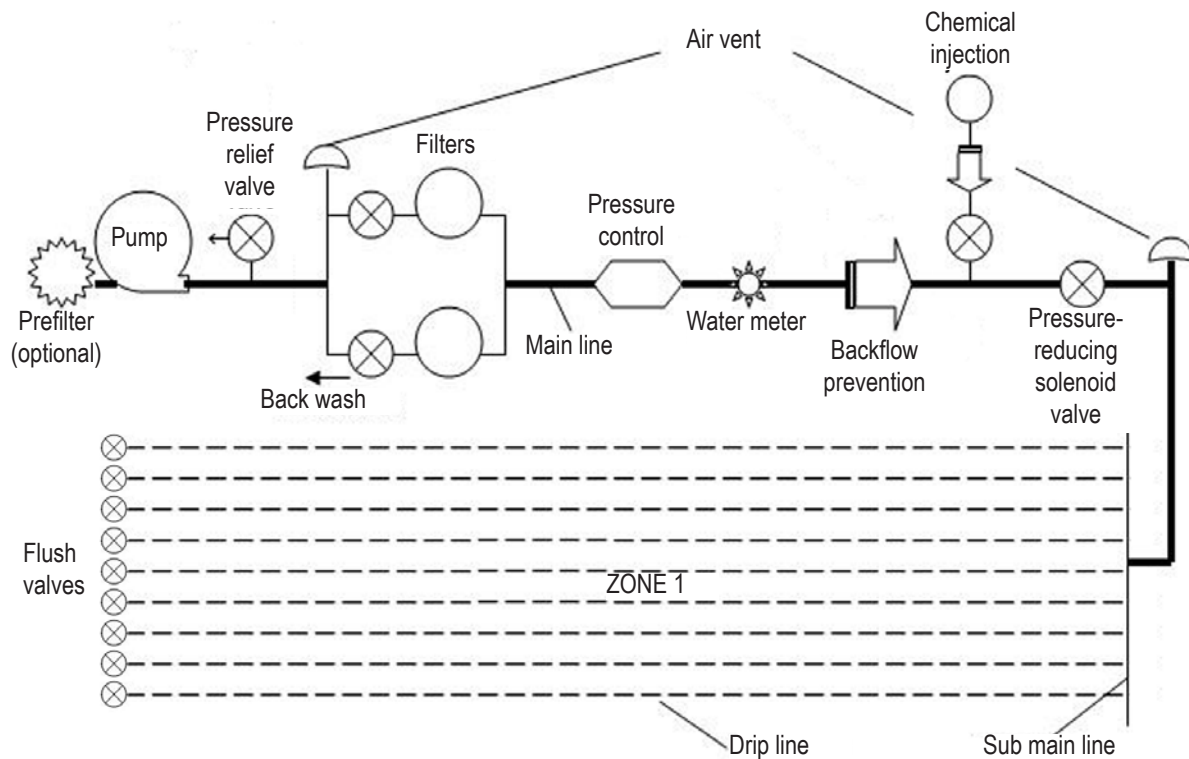

Figure 2. Drip irrigation system with a prefilter, pump station with backflow prevention, and chemical injection site. The chemical injection site should be after the main filter station. A pressure control valve is recommended to adjust the water pressure as desired before it enters the drip lines. A water meter can be placed after the pressure control. Vacuum relief is necessary between the solenoid valve and the drip tapes to avoid suction of soil into the emitters when the system is shut off.

## System maintenance

### Flow meter

A water flow meter should be an integral part of the system, and each zone's gauge should be recorded regularly. This provides a clear indication of how much water was applied to each zone. Water flow records can be used to detect deviations from the standard flow, which may be caused by leaks in the system or by clogged lines.

### Watch for leaks

Leaks can occur unexpectedly as a result of damage by insects, animals, weeding crews, or farming tools. Systematically monitor the lines for physical damage. It is important to fix holes as soon as possible in order to maintain system uniformity.

### Chlorine clears clogged emitters

If the rate of water flow progressively declines during the season, the tape may be slowly plugging, resulting in severe damage to the crop. The application of chlorine through the drip tape will help minimize clogging. Because algae growth and biological activity in the tape are especially high during June, July, and August, chlorine usually is applied at 2-week intervals during these months. Buffering the irrigation water to below pH 5.0 increases chlorine activity significantly. Use chlorine applications in moderation so that the chlorine cleans the emitters without affecting the soil environment.

If drip lines become plugged in spite of maintenance, many cleaning products are available through irrigation system suppliers.

Choose a product appropriate for the specific source of contamination.

In addition to the use of chlorine and maintaining the filtering stations, flush the drip lines once a month by opening the bottom ends of a portion of the tapes at a time and allowing the higher velocity water to wash out the sediment.

## Microirrigation criteria

### *Daily crop water use*

Irrigation application must reflect crop water use. Therefore, it is crucial to plan how much water to apply and when to apply it to optimize efficiency.

One aim of irrigation is to replace the daily crop evapotranspiration. Estimated daily onion evapotranspiration for the western Treasure Valley is available on the Malheur Experiment Station's website (<http://www.cropinfo.net>).

Water applied at any one irrigation should not exceed the soil's water-holding capacity. Different combinations of intensity, frequency, and flow rates can be customized to meet varying irrigation needs within a field.

### *Getting started*

During each irrigation the wetting pattern needs to reach or pass the base of the onion plants most distant from the drip tape. The first irrigation of the season establishes the wetting pattern and often is 24 to 36 hours long. Fine silts or salts in the soil can be moved laterally with the initial wetting front, and they can become fixed when the water ceases to move outward. Expanding a wetting pattern beyond this initial boundary can require an excessive amount of water. Once growers monitor the initial irrigation for the desired wetting pattern, subsequent irrigation sets should maintain the previously established wetting pattern. Onion plants growing beyond the wetting front usually have smaller bulb size.

The use of automated zone control greatly aids in maintaining an adequate wetting zone.

By pulsing the water in shorter sets, many times a limited amount of water can establish a larger wetted sphere than longer sets.

### *Water applied per irrigation and irrigation frequency*

Low-application, high-frequency irrigation has been identified as the ideal irrigation strategy for maximizing plant growth. Growers can expect to irrigate drip-irrigated fields more frequently than furrow-irrigated fields. The typical range for drip irrigation frequency is 1 to 2 days.

One reason for the need for more frequent irrigation with drip systems is simply that less water is applied per irrigation cycle. Also, moisture may be wicked away from the root zone as the irrigated plots and surrounding dry soil equilibrate. Since irrigations are small, drip irrigation causes significantly less erosion, less deep percolation, and less leaching than furrow irrigation.

Drip irrigation permits greater control and precision of irrigation timing and the amount of water applied. This flexibility to tailor a schedule based on local soil water tension (SWT), thus precisely matching crop needs, may be the greatest advantage of drip irrigation.

Irrigation *frequency* depends on the water applied: the lower the amount, the higher the frequency. The amount of water applied per irrigation is governed by the duration of the irrigation and the flow rate.

The irrigation application and frequency should be planned to keep the SWT at an optimal level without excessive leaching.

An onion irrigation amount and frequency study in 2002 and 2003 showed that the optimum amount on silt loam was no less than  $\frac{1}{2}$  inch per irrigation. Amounts of  $\frac{1}{8}$ ,  $\frac{1}{4}$ , and  $\frac{1}{16}$  inch per irrigation offered little or no advantage and slightly reduced the yield of colossal and super colossal onions (Shock et al, 2005). Practical limitations of the high-frequency, low-application principle include

excessive mainline drainage from very frequent irrigations and the need to dedicate water sources to one field.

The duration of the irrigations should be shortened if the second foot of soil is becoming very wet. The duration of the irrigations should be lengthened if the wetting front is not reaching from the drip tape all the way to the base of the onion plants.

### ***Emitter flow rate***

The drip tape emitters determine the flow rate of water into the plot. Drip tapes with lower water application rates make low-intensity, high-frequency irrigations more feasible by improving wetting pattern and uniformity. Low flow (0.13 gal h<sup>-1</sup>) and ultra-low flow (0.066 gal h<sup>-1</sup>) are two of the emitter options commercially available for silt loam. Practical limitation of ultra-low flow emitters became evident when these two types of emitters were compared against each other (Shock et al., 2005). Ultra-low-flow emitters reduced the yield of the largest bulb size class compared to low-flow emitters.

Ideal emitter flow rates depend on the soil type. Coarser soils usually require higher emitter flow rates.

### ***Why measure soil water tension?***

Soil water tension (SWT) is the measure of how strongly water is held in the soil. Onion yield and grade are related to the amount of energy needed for plant roots to remove water from the soil. SWT also provides information on soil saturation, which can help growers avoid saturating the soil, thereby maintaining aeration of plant roots and reducing leaching losses of water or nutrients. These factors make irrigation by SWT economically and environmentally important. Viewed in graphical form, the SWT clearly indicates the relative condition of the root zone of the crop over time.

The use of granular matrix sensors and tensiometers to determine crop water needs is

discussed in *Irrigation Monitoring Using Soil Water Tension*, EM 8900 (Shock et al., revised 2013).

### ***Recommended SWT***

Based on a 2-year study at the Malheur Agricultural Experiment Station (Shock et al., 2000), it is recommended that drip-irrigated onion in the Treasure Valley on silt loam be irrigated when SWT at the 8-inch depth reaches 20 centibars (cb). Note that lower numbers indicate wetter soil (0 = saturated; 100 = dry).

This recommendation is based on several factors. Research has shown that onion yield, size, and therefore profit, increase with decreasing soil water tension. In 1998, the highest yield and profit were in plots irrigated when the SWT was 10 cb. However, in 1997, onions irrigated at 10 cb displayed increased decomposition during storage. Depending on the year, onions irrigated at the lowest (wettest) soil water tension could be subject to longer periods of excessively wet soil, thereby promoting disease. Furthermore, fields irrigated at soil water tensions wetter than 17 cb exhibited deep percolation of water and increased risk of nitrate leaching.

Thus, the optimum SWT for maximizing profit and yield for the Treasure Valley grower producing onion on silt loam should be closer to 20 cb. This threshold takes into account the difficulty of predicting effects on storage quality and on the environment. Irrigation at 20 cb or slightly drier minimizes decomposition in storage.

### ***A pattern of water use***

Onions use very little water from the time they are planted through May. Water use slowly increases until early July, at which time the irrigation frequency must be increased to meet onion plant water needs. At some time in early August, water use starts to decrease, so the frequency of irrigations needs to start decreasing to avoid over-irrigation.

## Chemigation

Irrigation and fertilization should be managed together to optimize efficiency. Chemigation through drip systems efficiently deposits chemicals in the root zone of the receiving plants. Because of its precision of application, chemigation can be safer and use less material. Several commercial fertilizers and pesticides are labeled for delivery by drip irrigation.

Injection pumps with backflow prevention devices are necessary to deliver the product through the drip lines. These pumps allow for suitable delivery rate control. Backflow prevention protects both equipment and the water supply from contamination. Other safety equipment may be required; contact a drip-irrigation system supplier for details.

## Nitrogen fertilizers

Soil microorganisms convert nitrogen (N) fertilizers to nitrate. Nitrate is water soluble, available to plants, and subject to leaching loss. Since nitrate loss management was one of the initial reasons for exploring drip irrigation, it is appropriate that we revisit this topic.

When growers observed very high onion yields under drip irrigation, many assumed that greater yields would require increased N fertilizer. In fact, no more N than usual is required. Typically, *less* is needed because the fertilizer is spoon-fed to the root system with very limited loss. Nitrogen fertilizer normally is applied at a little more than half the customary rate because it is supplied directly to the root system and is not leached immediately from the root zone.

Furthermore, studies on furrow- and drip-irrigated onion have shown that N often is not the most limiting factor in Treasure Valley onion growth and therefore is not required to the extent that was previously thought. In a 3-year drip-irrigated study, N rate had no significant effect on onion yield, grade, or gross

returns, but the irrigation water contained some nitrate (Shock et al., 2004).

Consult *Nutrient Management for Sweet Spanish Onions in the Pacific Northwest* (PNW 546) to calculate whether N fertilization is needed to fully meet the onion crop's needs (Sullivan et al., 2001). Root tissue sampling allows for initially conservative N applications followed by N application via chemigation as needed. This has proven to be an effective means of achieving high yields.

## Buffering water pH

Systemic insecticides sometimes are used in drip systems for enhanced insect and nematode control. Normally, the product is introduced in the middle of the irrigation set, allowing a clean water period to push the product out of the drip tape and closer to the crop.

In some instances, a pH-buffering agent is needed to enhance the effectiveness of insecticides. A second injection pump is required for a pH-buffering agent.

## For more information

Burt, C.M. and S.W. Styles. 2011. *Drip and Micro Irrigation Design and Management for Trees, Vines, and Field Crops*. Cal Poly, San Luis Obispo, CA.

Gelski, Jeff. 2003. Avoid Filter Frustration. Available online at <http://www.growermagazine.com/home/02-03filters.html>

Lamm, F.R., J.E. Ayars, and F.S. Nakayama (eds.). 2007. *Microirrigation for Crop Production—Design, Operation and Management*. Elsevier Publications. <http://www.elsevier.com/books/microirrigation-for-crop-production/lamm/978-0-444-50607-8>

Schwankl, L.J. 2013. Maintenance of Microirrigation Systems (website). <http://ucanr.org/sites/Microirrigation>

Shock, C.C., E.B.G. Feibert, and L.D. Saunders. 2000. Irrigation criteria for drip-irrigated onions. *HortScience* 35:63–66.

Shock, C.C., E.B.G. Feibert, and L.D. Saunders. 2004. Plant population and nitrogen fertilization for subsurface drip-irrigated onion. *HortScience* 15:7–14.

Shock, C.C., E.B.G. Feibert, and L.D. Saunders. 2005. Onion response to drip irrigation intensity and emitter flow rate. *HortTechnology* 39:1722–1727.

Shock, C.C. and F.X. Wang. 2011. Soil water tension, a powerful measurement for productivity and stewardship. *HortScience* 46:178–185

Shock, C.C. Revised 2013a. *Drip Irrigation: An Introduction*. Oregon State University Extension publication EM 8782. Available online at <http://ir.library.oregonstate.edu/xmlui/bitstream/handle/1957/20206/em8782-e.pdf>

Shock, C.C., F.X. Wang, R.J. Flock, E.B.G. Feibert, C.A. Shock, and

A.B. Pereira. Revised 2013b. *Irrigation Monitoring Using Soil Water Tension*. Oregon State University Extension publication EM 8900. Available online at <http://ir.library.oregonstate.edu/xmlui/bitstream/handle/1957/20424/em8900.pdf>

Sullivan, D.M., B.D. Brown, C.C. Shock, D.A. Horneck, R.G. Stevens, G.Q. Pelter, and E.B.G. Feibert. 2001. *Nutrient Management for Sweet Spanish Onions in the Pacific Northwest*. Pacific Northwest Extension publication PNW 546. 26 pp.

For more Extension publications on irrigation management, visit the OSU Extension website at <http://extension.oregonstate.edu>

### Acknowledgments

Funding to help prepare this publication was provided by a grant from the Oregon Watershed Enhancement Board Grant.

## Quick Facts

- Drip irrigation is the slow, even application of low-pressure water to soil and plants using plastic tubing placed near the plants' root zone.
- Drip irrigation systems facilitate water management in fields that are difficult to irrigate due to variable soil structure or topography.
- Onion yield and grade respond very sensitively to irrigation management.
- Recommended soil water tension for irrigation onset for drip-irrigated onion is 20 centibars (cb) on silt loam.
- Seasonal water needs for drip-irrigated onion are 28 to 32 inches, depending on the year.
- “Soil water potential” is the negative of “soil water tension.” A soil water potential of -20 cb is the same as a soil water tension of +20 cb. Also, cb is the same as kPa (kilopascals).
- Drip systems require careful design and maintenance.

© 2013 Oregon State University.

Extension work is a cooperative program of Oregon State University, the U.S. Department of Agriculture, and Oregon counties. Oregon State University Extension Service offers educational programs, activities, and materials without discrimination based on age, color, disability, gender identity or expression, genetic information, marital status, national origin, race, religion, sex, sexual orientation, or veteran's status. Oregon State University Extension Service is an Equal Opportunity Employer.

Trade-name products and services are mentioned as illustrations only. This does not mean that the Oregon State University Extension Service either endorses these products and services or intends to discriminate against products and services not mentioned.

Published December 2005. Revised January 2013.