

**Improving the Performance of Multispan Logging Systems
by Suspending the Mainline**

by

Thomas A. Durston

A THESIS

submitted to

Oregon State University

in partial fulfillment of
the requirements for the
degree of

Master of Science

Completed September 2, 1988

Commencement June 1989

APPROVED:

Professor of ~~Forest~~ Forest Engineering
in charge of ~~major~~ major

Head of Department of Forest Engineering

Dean of Graduate School

Date thesis is presented September 2, 1988

Typed by Thomas A. Durston for Thomas A. Durston

AN ABSTRACT OF THE THESIS OF

Thomas A. Durston for the degree of MASTER OF SCIENCE
in FOREST ENGINEERING presented on September 2, 1988.

Title: Improving the Performance of Multispan Logging Systems by
Suspending the Mainline

Abstract approved: _____
Dr. John Sessions

Multispan skyline logging systems are cable systems designed to yard logs over steep terrain having a constant or convex slope. An intermediate skyline support is used to raise the skyline high enough to achieve ground clearance without overstressing the skyline. Certain improvements in performance can be realized by providing intermediate support for the mainline as well as the skyline.

A computer model has been developed to compare the performance of two possible suspended-mainline multispan logging systems. One of the systems is capable of suspending the mainline at the skyline intermediate support using a compound jack, and the other, the squirrel carriage, suspends the mainline from a pair of sheaves which are free to change location under the influence of cable forces.

The computer model is capable of predicting the effect of different parameters on the performance of the logging systems. Simulations on a typical logging setting, varying one parameter at a time, suggest that:

(1) Either system of suspending the mainline can potentially improve net payload, ground clearance of the mainline, and the likelihood of successful passage of the skyline carriage over the intermediate support jack.

(2) The compound jack system is capable of better performance than the squirrel carriage system under most conditions.

(3) The squirrel carriage system performance improves on steeper slopes and with optimum squirrel carriage weight. Squirrel carriage performance worsens as the ground profile becomes more convex.

Table of Contents

1 . INTRODUCTION	1
1.1 Objectives	6
1.2 Scope	7
1.3 Literature Review	7
2 . MODEL DEVELOPMENT	10
2.1 Catenary and Elliptical Load Path Relationships	12
2.2 Single Segment Analysis	18
2.2.1 Given TUP, D and HY	19
2.2.2 Given FH, D and HY	19
2.3 Multiple Segment Analysis	20
2.4 Payload Analysis of Conventional Multispan	20
2.4.1 Determination of Unstretched Skyline Length	20
2.4.2 Tension-Limited Payload Analysis	21
2.4.3 Load Path Analysis	25
2.4.4 Force on the Intermediate Support	28
2.4.5 Height of Mainline Above Ground	29
2.4.6 Likelihood of Jack Passage	30
2.5 Payload Analysis of Compound Jack System	32
2.6 Payload Analysis of Squirrel Carriage	36
2.6.1 Unstretched Skyline Length	40
2.6.2 Forces for a Given Geometry and Tension	41
2.6.3 Squirrel Carriage Horizontal Location	44
2.6.4 Search for Carriage Height	45
2.6.5 Search for Squirrel Carriage Height	46
2.6.6 Mainline Tension Check	46
2.6.7 Load Path	46
2.6.8 Forces on the Intermediate Support	47
2.6.9 Mainline Ground Clearance	47
3 . LOGGING PERFORMANCE PREDICTIONS UNDER VARYING CONDITIONS	48
3.1 Payload Capacity	52
3.2 Mainline Clearance Above Ground	53
3.3 Carriage Passage over the Jack	54
3.4 Location of the Squirrel Carriage	55
3.5 Force on the Intermediate Support	59
3.6 Parameter Study	60
3.6.1 Effect of Ground Slope	61
3.6.2 Effect of Chord-Slope Break	69
3.6.3 Effect of Squirrel Carriage Weight	71
3.6.4 Effect of Ratio of Upper Span Distance to Total Span Distance	74
3.6.5 Effect of Total Horizontal Span Distance	76
4 . CONCLUSIONS AND RECOMMENDATIONS	78
4.1 Conclusions	78
4.2 Recommendations	79

5. FURTHER RESEARCH	81
6. REFERENCES	82
7. TERMINOLOGY (APPENDIX A)	84
8. SAMPLE OUTPUT (APPENDIX B)	86
9. PROGRAM LISTINGS (APPENDIX C)	91

List of Figures

Figure 1. Types of Multispan Logging Systems	3
Figure 2. Possible system designs to suspend the mainline	5
Figure 3. Single Segment Variable Definition Sketch	14
Figure 4. Conventional Multispan Geometry and Free Body Diagrams	23
Figure 5. Jack passage parameters	31
Figure 6. Compound Jack System Geometry and Free Body Diagrams	34
Figure 7. Squirrel Carriage Subroutine Flowchart.	37
Figure 7. Squirrel Carriage Subroutine Flowchart, continued.	38
Figure 7. Squirrel Carriage Subroutine Flowchart, concluded.	39
Figure 8. Squirrel Carriage Geometry and Free Body Diagrams	42
Figure 9. Standard Profile	51
Figure 10. Squirrel Carriage Location, Standard Case	57
Figure 11. Horizontal Force on Squirrel Carriage	58
Figure 12. Squirrel Carriage Location, 20% Slope	62
Figure 13. Squirrel Carriage Location, 40% Slope	63
Figure 14. Squirrel Carriage Location, 60% Slope	64
Figure 15. Payload by Slope and System Type	66
Figure 16. Mainline Clearance by Slope and System	67
Figure 17. Jack Passage Indicator Angles by Slope and System	68
Figure 18. Angle of Separation Between Skyline and Mainline	70
Figure 19. Payload by Slope Break Angle and System	72
Figure 20. Payload by Squirrel Carriage Weight	73
Figure 21. Payload by Percentage of Total Span in Upper Span	75
Figure 22. Payload by Horizontal Span Distance	77

List of Tables

Table 1. Standard Profile, Setting and Yarder	49
Table 2. Payload by System Type in Standard Case	53
Table 3. Mainline Clearance by System in the Standard Case	54
Table 4. Jack Passage Indicator Angles by System in the Standard Case	55
Table 5. Force on the Intermediate Support in the Standard Case	60
Table 6. Horizontal Coordinate of Squirrel Carriage by Slope Break	71

IMPROVING THE PERFORMANCE OF MULTISPAN LOGGING SYSTEMS BY SUSPENDING THE MAINLINE

1. INTRODUCTION

Skyline logging is used extensively in mountainous forest land in the Pacific Northwest region of the United States. On slopes exceeding 35%, aerial logging systems such as skyline, helicopter or balloon are used instead of more economical ground-based skidding systems in order to limit soil damage.

Single span skyline systems are used when sufficient "lift" or "deflection" is available. When the ground profile is constant or convex, however, the skyline may need to be supported at an intermediate point in the span to give sufficient ground clearance and payload capacity. A skyline system with such an intermediate support is called a multiple span or "multispan" skyline system.

In multispan skyline settings, if deflection is limited, payload capacity may be relatively low. Also the mainline may tend to drag on the ground, especially on long, convex profiles. Dragging of the mainline on the ground causes line wear from abrasion and can result in fires. Also, under some conditions, the carriage may "hang up" at the intermediate support jack, tending to move under the jack instead of passing smoothly over it.

Raising the mainline higher at some point in the spans can help alleviate these problems. Some European and American loggers have used a device called a squirrel block or squirrel carriage (Fig. 1) to achieve the desired lift on the mainline. ("Squirrel" because the block can travel up the cable like a squirrel climbing a tree.)

A squirrel carriage is a pair of connected blocks or sheaves which ride on the skyline between the carriage and the headspar. The upper block travels on the skyline and suspends the lower block. The lower block is used to suspend the mainline. When the squirrel carriage is separated from the carriage, the mainline is suspended higher than it would be without a squirrel carriage. Since the mainline pulls up on the carriage from a higher point, it imparts a higher vertical component of tension on the carriage, improving payload capacity. The suspension of the mainline may also eliminate the dragging of the mainline on the ground. Finally, the improved angle of pull has the potential to help the carriage pass over the intermediate support jack in marginal cases.

Unfortunately, with a squirrel carriage that is free to move on the skyline, the location of the squirrel carriage may not be ideal for improving the logging system performance. The skyline intermediate support is generally located strategically at the break in slope on convex ground profiles, and near the middle of the setting.

To achieve the maximum lift on the mainline, either the squirrel carriage should be restrained at the jack while the carriage is in the lower span, or the mainline should be suspended from a roller attached to the same jack that supports the skyline. A system capable of supporting the mainline from the intermediate support jack could be called a "compound jack" system.

At least one compound jack system is commercially available. This system, the BN20RA jack made by Iwafuji Industrial Co., Ltd., of Tokyo, Japan, uses a roller below and offset to the side from the skyline jack to support the mainline. Another possible design is the running skyline carriage and support designed by Bergstrom (1988).

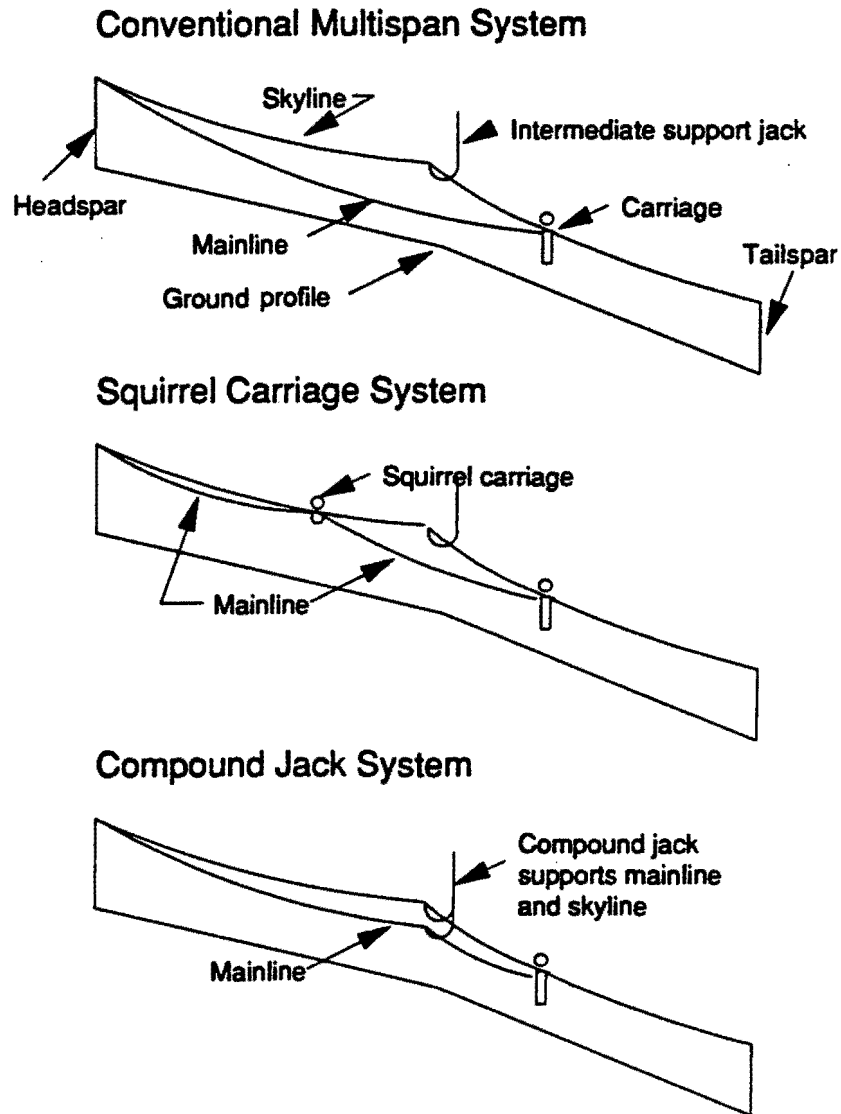

Figure 1. Types of multispan logging systems.

Fig. 2 shows these three possible approaches to suspending the mainline at the jack. The offset mainline support in Fig. 2A requires the jack to swing out of the way of the payload as it passes. Iwafuji uses this approach with a Tyler system carriage. The design in Fig. 2B, suggested by Bergstrom, has a slackpulling drum and dropline drum below the mainline support and a mainline drum above the mainline support to mechanically pull out dropline, or "pull slack", for lateral yarding. The mainline and lower drums are connected by a chain drive. If mechanical slackpulling were not required, a much simpler design with no drums or slackpulling line would be possible. Fig. 2C suggests some type of clamp attached to the jack which catches the squirrel carriage as the carriage passes on outhaul and releases it as the carriage passes the jack on inhaul.

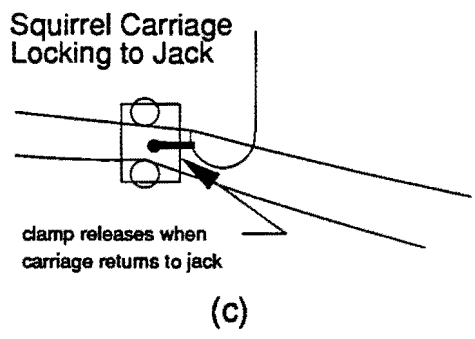
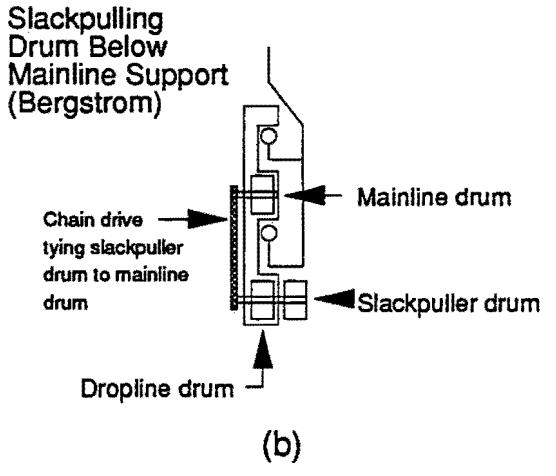
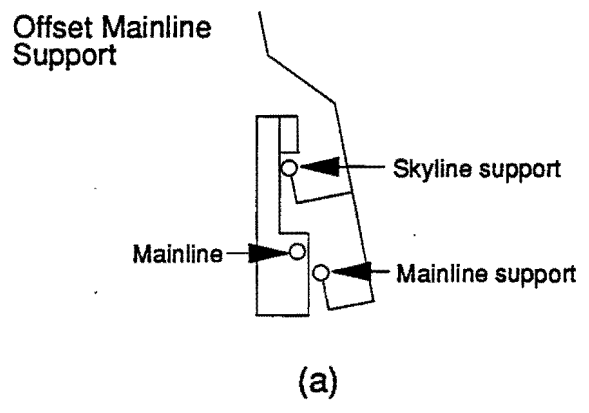

Figure 2. Possible System Designs to Suspend the Mainline

1.1 Objectives

The primary objective of this research project is to develop a mathematical model to describe the performance of the squirrel carriage.

Other objectives are to:

- 1) develop mathematical models describing the performance of conventional multispans and compound jack multispans skyline systems,
- 2) determine the effect of various yarding system and ground profile parameters on performance of each system, and
- 3) draw conclusions about the usefulness of the squirrel carriage and compound jack systems in various conditions.

1.2 Scope

The scope of this research is the development of a computerized skyline analysis model to predict the performance of the conventional, squirrel carriage and compound jack multispan skyline logging systems and the application of the model to draw conclusions about the applicability of the systems. The scope of the research is limited to:

- 1) Analysis of static forces only,
- 2) Fully suspended payloads (no log drag forces),
- 3) An idealized jack which does not sway or resist cable slippage,
- 4) A two span setting, and
- 5) A strictly mathematical model without physical testing for model validation.

1.3 Literature Review

Literature describing skyline payload analysis and the catenary relationships often used in the analysis is readily available. A discussion of multispan skyline analysis is included in many of these works on skyline analysis, but discussions of methods of suspending the mainline in multispan logging are rare.

Anderson (1921) presented one of the earliest analyses of cable logging mechanics. He developed some important catenary relationships, described some useful

catenary properties and presented a method of solution for a simple skyline problem. Mills (1932) extended Anderson's results and presented a simpler and more general method for solving the two-segment skyline problem.

An early treatment of skyline payload analysis by Lysons and Mann (1967) presented a method of solution of single span and multispans problems including the mainline. This method also used catenary theory, and used a "chain and board" scale model and tables and graphs of solutions to certain catenary relationships.

Subsequent work has substituted computer routines solving catenary relationships or simpler mathematical models (such as the rigid link or improved rigid link models) for the chain and board and tables and graphs. Carson (1977) presented a set of computer-oriented algorithms for the catenary relationships most commonly encountered in skyline analysis. He also demonstrated a basic method of solution for the forces in multiple segment systems. Building on the basis of this multiple segment analysis method, Carson (1975), Nickerson (1980), Cain (1987) and others have published user-friendly computer programs capable of analyzing a variety of typical skyline logging systems, including multispans systems. Chung (1987) published a relatively thorough description of the procedure used in solving the multispans problem.

Most studies of skyline mechanics use static equilibrium force analyses. A good analysis of dynamic forces in cables was published by the Electric Power Research Institute (Peyrot et al. 1978). In studies of dynamic effects of failure of electric power lines, the Electric Power Research Institute modeled dynamic effects by applying dynamic load factors to loads calculated by static equilibrium analysis.

The squirrel carriage was mentioned by Studier and Binkley (1974) as a device used to reduce sag in the mainline and facilitate slack pulling by hand. I found no other literature discussing squirrel carriage performance or analysis techniques.

Information related to solution of the squirrel carriage problem includes the collection of catenary relationships and other skyline analysis techniques by Sessions (1986). Also, Slepko and Pustovoitov (1974) and Larsen, et al (1985) have analyzed multispan systems with multiple loads. Slepko and Pustovoitov developed an analytical technique based on the parabolic model of cable behavior. Larsen et al. (1985) used an elastic cable model developed by Gonsior (1987), which is similar to the catenary model. Larsen's method requires an iterative solution based on successive estimates of cable slope. The squirrel carriage behaves somewhat like the multiple loads in the models of Slepko and Larsen, but differs in that it is free to roll along the skyline and its location must be determined from equilibrium force balance.

I found no publications and little information on the performance of compound jack. Bergstrom (1987) studied the problem with respect to running skylines. Bergstrom built a scale model of a multispan running skyline jack and carriage which could be modified to accommodate a standing multispan skyline system. Iwafuji Industrial Company (1987) manufactures a patented carriage and jack system, the BN20RA, capable of suspending the mainline. Iwafuji, however has not published skyline analysis methods or comparative performance data for their system.

2 . MODEL DEVELOPMENT

A mathematical model was created to describe the performance of the conventional, compound jack and squirrel carriage skyline logging systems. The model has been implemented with a computer program, MULTI which consists of two subprograms, SQ.BAS and UTIL.BAS, written in Turbo BASIC. The listings of SQ.BAS and UTIL.BAS are included in Appendix C.

Development of the squirrel carriage model is an original contribution to skyline cable mechanics. Based on the methods of conventional multispan skyline analysis, it permits analysis of squirrel carriage performance, apparently for the first time. The compound jack model is also original, and allows prediction of performance of this logging system. However, the compound jack model required only adaptation of conventional multispan analysis methods (Chung, 1987) rather than development of new concepts.

With respect to cable properties and skyline system properties, I assume that:

- 1) The cable segments behave as catenaries. That is, the cable bends without resistance, like a chain, and has uniform weight per foot of length.
- 2) The cable stretches according to Hooke's Law, but the variation of cross sectional area and unit weight due to stretch are negligibly small.
- 3) All elements of the cable logging system are in static equilibrium at each analysis point.

- 4) Friction forces between cable and jack and friction in the sheaves are negligibly small.
- 5) The intermediate support jack and headspar and tailspar remain fixed in their original positions.
- 6) The load is fully suspended above the ground.
- 7) The carriage is not clamped to the skyline.
- 8) In the upper span, the squirrel carriage rolls out with the carriage during outhaul and comes in with it during inhaul. (This effectively assumes that the vertical separation between mainline and skyline is no greater at the carriage than at the squirrel carriage, and that dynamic force effects are negligible.)
- 9) The profile is oriented with the headspar to the left.

The catenary assumption is used rather than the parabolic or rigid link models of cable behavior because:

- 1) The parabolic model assumes that the cable is loaded uniformly per foot of horizontal distance, as in a suspension bridge. In skyline systems, it is the weight of the cable, not a bridge deck or other uniform load, which loads the single cable segment. The cable weight is distributed uniformly along the length of the cable, as the catenary model assumes.

- 2) The rigid link model, like the parabolic model, assumes that the center of mass of the cable segment is at the midpoint of the segment. It also neglects sag of the cable, which is a significant consideration in relatively slack lines, such as the mainline under low load conditions.

The assumption of static equilibrium is not strictly true since the skyline system is in static equilibrium only when the carriage and squirrel carriage are stationary. In terms of payload, the current approach to dynamic forces seems to be to analyze static forces and allow a factor of safety for dynamic loading, an approach similar to that used by the power transmission industry (Peyrot, et al. 1978).

In the following model development I assume that vertical cable forces are positive upward on the left end of the segment and positive downward on the right end of the segment.

2.1 Catenary and Elliptical Load Path Relationships

The principle catenary relationships used in the model, taken from a number of sources (Sessions, 1986), follow. The variables are illustrated in Fig. 3.

$$S = \sqrt{HY^2 + [2M \sinh\left(\frac{D}{2M}\right)]^2} \quad [1]$$

$$TUP = \frac{\omega}{2} [S \coth\left(\frac{D}{2M}\right) + HY] \quad [2]$$

$$FH = \omega \times M \quad [3]$$

$$VUP = \sqrt{TUP^2 - FH^2} \quad [4]$$

$$TLO = TUP - \omega \times HY \quad [5]$$

$$VLO = VUP - \omega \times S \quad [6]$$

$$THETAUP = \tan^{-1}\left(\frac{VUP}{FH}\right) \quad [7]$$

$$THETALO = \tan^{-1}\left(\frac{VLO}{FH}\right) \quad [8]$$

$$HY = \frac{TUP - TLO}{\omega} \quad [9]$$

where:

HY = vertical projection of segment length, feet

D = horizontal projection of segment length, feet

ω = cable weight per unit length, pounds/foot

S = segment length (including stretch), feet

TUP = tension at upper end of segment, pounds

FH = horizontal component of segment tension at any point, pounds

VUP = vertical component of segment tension at upper end, pounds

TLO = tension at lower end of segment, pounds

VLO = vertical component of segment tension at lower end, pounds

THETAUP = direction of action of TUP measured up from horizontal, radians

THETALO = direction of action of TLO measured down from horizontal, radians.

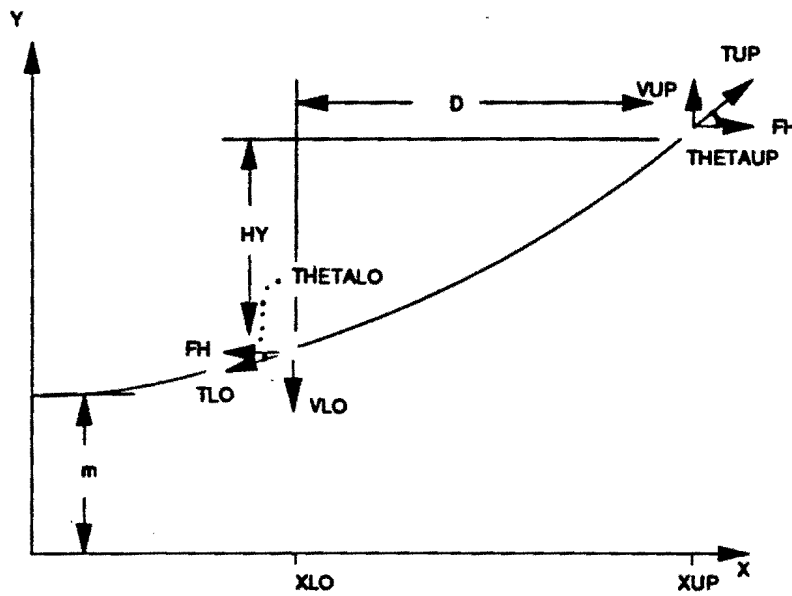

Figure 3. Single Segment Variable Definition Sketch

Segment stretch is estimated from (Inglis, 1951):

$$\text{STRETCH} = \left(\frac{\omega M}{2 A E M O D} \right) \times \left(\frac{M}{2} \right) \times \left[\sinh \left(\frac{2 X U P}{M} \right) - \sinh \left(\frac{2 X L O}{M} \right) + X U P - X L O \right] \quad [10]$$

where:

STRETCH = elongation of segment due to tension, feet

XUP = horizontal distance from the catenary origin to the upper segment endpoint, feet

XLO = horizontal distance from the catenary origin to the lower segment endpoint, feet, and

EMOD = cable elastic modulus, psi.

XUP and XLO can be computed from:

$$XUP = M \cosh^{-1} \left(\frac{TUP}{\omega M} \right) \quad [11]$$

$$XLO = M \cosh^{-1} \left(\frac{TLO}{\omega M} \right) \quad [12]$$

Note that if the segment passes through a sag point, XLO should be reversed in sign.

When HY is needed as to find the difference in elevation along a segment between two known horizontal coordinates, it can be found from:

$$HY = 2M \sinh\left(\frac{D}{2M}\right) \times \sinh\left[\ln\left(\tan(\text{THETALO}) + \sqrt{\tan^2(\text{THETALO}) + 1} + \frac{D}{2M}\right)\right] \quad [13]$$

The "elliptical load path" formula is a relationship between skyline length and carriage elevation. Assuming that the skyline behaves like a weightless inextensible line, the carriage travels on a path tracing the perimeter of an ellipse with the two skyline supports at the foci of the ellipse. The difference, Δ , in elevation between the left support and a point on the elliptical load path can be shown to be (Holthorf, 1982):

$$\Delta = YLT - \frac{CY \pm \sqrt{C^2 \text{SELLIPT}^2 - 4D^2 \text{SELLIPT}^2 (\text{SELLIPT}^2 - Y^2)}}{2(\text{SELLIPT}^2 - Y^2)} \quad [14]$$

where:

$$C = \text{SELLIPT}^2 + D^2 - (\text{HSD} - D)^2 - Y^2, \quad [15]$$

HSD = the horizontal distance between supports,

D = the horizontal distance from the left support to the terrain point,

SELLIPT = the radius of the ellipse,

YLT = the elevation of the left support, and

Y = the difference in elevation between the left and right supports.

The plus sign before the square root in Eq. [14] applies when the left support is higher than the right support.

2.2 Single Segment Analysis

Techniques of analysis of the single cable segment as a catenary are well documented by Carson (1977). Logging systems can be described as a system of individual cable segments, divided at supports or loads. For instance, a typical segment is the skyline segment from the headspar to the carriage. To fully define the state of any single segment, three parameters must be determined, from which all the other parameters can be computed. In the model, the known parameters are either (1) the upper end tension, TUP, horizontal projection of length, D, and vertical projection of length, HY, or (2) the horizontal force projection, FH, and D and HY. The procedures to calculate cable parameters given these two cases follow.

2.2.1 Given TUP, D and HY

For skyline segments and those mainline segments not adjacent to the carriage, TUP, D and HY are determined first. From these three segment parameters and the cable unit weight, ω , the catenary parameter M is computed using the iterative search method presented by Carson (1977). The search begins by estimating the segment weight, R, and center of gravity, E, assuming it is a straight rigid link between the endpoints. Given R and E, M is estimated, and with M, new values are estimated for R and E for the next iteration. The search usually converges to M with a high degree of precision within 4 or 5 iterations. Following computation of M, all other segment parameters can be computed using Eqns. [1] through [13].

2.2.2 Given FH, D and HY

For mainline segments attached to the carriage, TUP is not known, but FH can be found from horizontal force balance at the carriage. The geometry parameters D and HY are also known or assumed. M is readily computed from Eqn. [3] and all other segment parameters are computed from Eqns. [1] through [13].

2.3 Multiple Segment Analysis

Analysis of multiple segment systems requires the computation of forces in one segment whose parameters are fully known or assumed. Calculations begin with the upper segment of the skyline with TUP equal to the safe working load of the skyline. When the first segment is fully defined, the boundary conditions of the next segment can be found and its forces and length can be found. This process continues segment by segment until all segments are fully defined. In an iterative procedure where one or more parameters were assumed, certain results for lengths or forces may be found to be physically incorrect, and new input assumptions are made for the next iteration.

2.4 Payload Analysis of Conventional Multispan

The analysis of the conventional multispan system can be subdivided into three phases: determination of unstretched skyline length, tension-limited payload analysis and load path analysis. The following approach is similar to that of Chung (1987).

2.4.1 Determination of Unstretched Skyline Length

Multispan skyline systems are operated as standing skylines. Once the skyline is raised, the skyline drum is locked. The unstretched length of the skyline remains constant, but due to variations in skyline tension as the load moves up the skyline, the stretched length or actual length of the skyline varies.

The unstretched skyline length for a profile is taken as the length which, when stretched, results in the specified carriage clearance at the critical point. To compute the critical unstretched skyline length, SOCRIT, a simplified payload analysis is performed at each terrain point. The carriage is placed at the specified minimum clearance at each point and D and HY are found for the two segments in the loaded span. D and HY of the segment in the unloaded span are also known. The skyline tension at the headspar is assumed to be the maximum allowable tension, T1MAX. Following the rules of multiple segment analysis, the TUP, D and HY of each segment are found, and each segment is analyzed using the single segment analysis procedure with stretch. The terrain point at which the total unstretched skyline length is the least is the critical point and the unstretched length is SOCRIT. The stretched length of the skyline, SCRIT, is also saved.

2.4.2 Tension-Limited Payload Analysis

The first output of the model is the maximum payload at each terrain point for the given unstretched skyline length, SOCRIT and the allowable tensions in the skyline and mainline.

The first intermediate solution computed at a terrain point generally does not have the correct unstretched skyline length. This is because SOCRIT is not an input to the

payload analysis but a result from the assumed carriage height and skyline tension.

Therefore, the carriage height, $Y(TP)$, must be varied in an iterative search to find the solution for which the unstretched skyline length is equal to $SOCRIT$.

In the search, $Y(TP)$ is not varied directly. Instead, $SELLIPT$, the elliptical load path parameter, is used as the independent variable and $Y(TP)$ is computed as a function of $SELLIPT$ using Eq. [14]. In general, $SELLIPT$ is used rather than carriage or squirrel carriage height as the independent variable for all searches where the carriage height or squirrel carriage height is being varied, because convergence is faster.

The multiple segment analysis (Fig. 4) performs steps (1) through (8) below:

1) In the unloaded span, skyline segment U:

Assume $TULT = T1MAX$, usually the skyline safe working load. DU and HYU are known. Solve for forces and lengths in segment U.

2) Assume carriage height $Y(TP)$. The elliptical load path location is a very good first guess. For the parameter $SELLIPT$, the length $SCRIT$ less the stretched length of the unloaded span should be used.

3) For skyline segment 1, jack to carriage:

$T1LT = TURT$ since the skyline is continuous across the jack and friction is negligibly small. $D1$ and $HY1$ are now known or assumed. Solve for forces and lengths in segment 1.

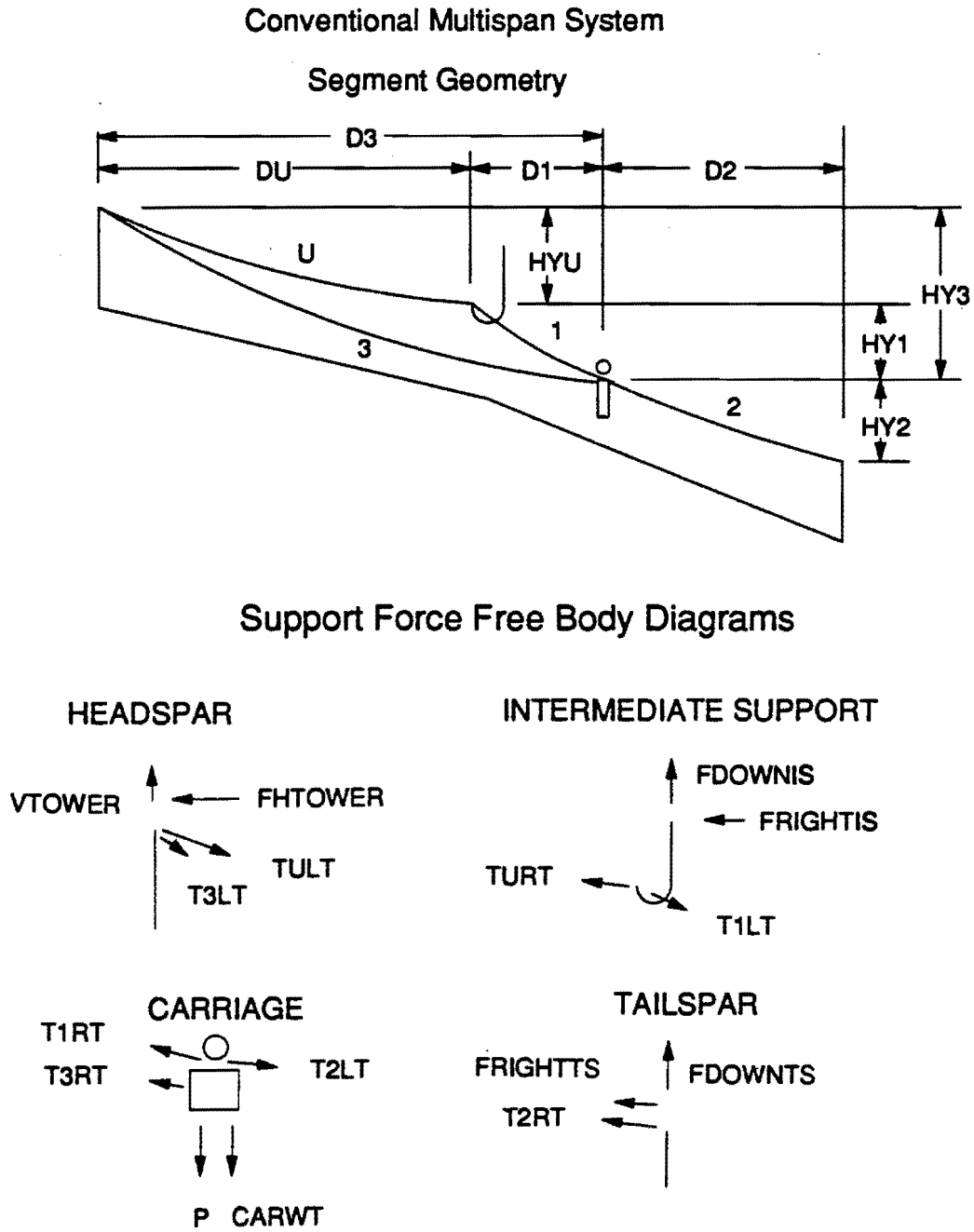

Figure 4. Conventional Multispan Geometry and Free Body Diagrams.

- 4) In skyline segment 2, carriage to tailspar:

$T2LT = T1RT$ since the skyline is continuous through the carriage sheaves and friction is negligibly small. $D2$ and $HY2$ are known for the assumed $Y(TP)$.

Solve for forces and lengths in segment 2.

- 5) For mainline segment 3, headspar to carriage:

The mainline tension is not known, but the horizontal component $FH3$ can be found from horizontal force balance at the carriage:

$$FH3 = FH2 - FH1 \quad [16]$$

Solve for forces and lengths in segment 3.

- 6) Find the unstretched skyline length $S0TOTAL$ by summing the unstretched line lengths of segments U, 1 and 2.

- 7) If the computed unstretched skyline length is sufficiently close to $SOCRIT$, then go to step 8 to compute the payload. Otherwise, estimate a new $Y(TP)$ and return to step 3. A secant search is used.

- 8) The net payload can be computed from vertical force equilibrium at the carriage:

$$P = V1RT + V3RT - V2LT - CARWT \quad [17]$$

where:

$V1RT$ = the vertical component of cable tension $T1RT$, pounds,

$V2LT$ = the vertical component of cable tension $T2LT$, pounds,

$V3RT$ = the vertical component of cable tension $T3RT$, pounds, and

CARWT = carriage weight, pounds.

After the solution is found using T1MAX as the upper end skyline tension, the maximum mainline tension is checked. If the mainline tension exceeds the specified safe working load, a new solution is found in which the maximum mainline tension approximately equals the specified tension. Rather than use an entirely different procedure in which mainline tension is an input parameter, the model varies the maximum skyline tension, T1MAX, in a secant search until the desired result for mainline tension is obtained.

Before beginning the search, the minimum skyline tension, MINT1MAX, required for an unstretched skyline length of S0CRIT is calculated. MINT1MAX is found using a secant search varying T1MAX. The secant search in the mainline tension check subroutine is not allowed to try a value of T1MAX less than MINT1MAX.

2.4.3 Load Path Analysis

The load path analysis computes the forces for a constant payload at each terrain point. The loadpath computation requires a search for two independent parameters, upper end skyline tension, T1MAX, and carriage height, Y(TP), based on two dependent variables, payload, P, and unstretched skyline length, S0TOTAL.

Previous multispan payload analysis programs required the user to input trial values for gross payload and S0TOTAL in a trial and error search (Nickerson, 1980), but this model and other recent models include search routines which do not require user intervention (Cain, 1987).

The search could be performed by two nested secant search routines, however, for computational efficiency, this research project developed a two-dimensional application of the steepest ascent gradient search method. The gradient search generally converges to within 0.5 pound of the specified payload and 0.005 foot of the specified S0CRIT within seven or eight iterations. Convergence is usually successful for terrain points as close to the intermediate support as 0.1 foot.

The gradient search is based on linear approximations of the partial derivatives of P and $S0TOTAL$ with respect to $T1MAX$ and $Y(TP)$. To compute the partial derivatives, the payload analysis is computed with the estimated values of $T1MAX$ and $Y(TP)$, and then at two nearby points ($T1MAX + \delta T1MAX$, $Y(TP)$) and ($T1MAX$, $Y(TP) + \delta Y(TP)$). The partial derivatives are computed from:

$$f_{11} = \frac{P(Y(TP) + \delta Y(TP), T1MAX) - P(Y(TP), T1MAX)}{\delta Y(TP)} \quad [18]$$

$$f_{21} = \frac{S0TOTAL(Y(TP) + \delta Y(TP), T1MAX) - S0TOTAL(Y(TP), T1MAX)}{\delta Y(TP)} \quad [19]$$

$$f_{12} = \frac{P(Y(TP), T1MAX + \delta T1MAX) - P(Y(TP), T1MAX)}{\delta T1MAX} \quad [20]$$

$$f_{22} = \frac{S0TOTAL(Y(TP), T1MAX + \delta T1MAX) - S0TOTAL(Y(TP), T1MAX)}{\delta T1MAX} \quad [21]$$

where:

f_{11} = the partial derivative of payload with respect to carriage height,

f_{21} = the partial derivative of unstretched skyline length with respect to carriage height,

f_{12} = the partial derivative of payload with respect to upper end skyline tension,

f_{22} = the partial derivative of unstretched skyline length with respect to upper end skyline tension,

$P(Y(TP), T1MAX)$ = net payload given carriage height $Y(TP)$ and upper end skyline tension $T1MAX$,

$S0TOTAL(Y(TP), T1MAX)$ = unstretched skyline length given carriage height $Y(TP)$ and upper end skyline tension $T1MAX$,

$\delta Y(TP)$ = perturbation in carriage elevation, and

$\delta T1MAX$ = perturbation in $T1MAX$.

The new point $(T1MAX + \Delta T1MAX, Y(TP) + \Delta Y(TP))$ is found from:

$$\Delta T1MAX = \frac{P0 - P(Y(TP), T1MAX) - (f_{11}/f_{12})(S0CRIT - S0TOTAL(Y(TP), T1MAX))}{f_{12} - \frac{f_{11}f_{22}}{f_{21}}} \quad [22]$$

and,

$$\Delta Y(TP) = \frac{P_0 - P(Y(TP), T1MAX) - f_{12} \Delta T1MAX}{f_{11}} \quad [23]$$

where:

$\Delta T1MAX$ = the increment to T1MAX for the next point, and

$\Delta Y(TP)$ = the increment to Y(TP) for the next point.

To avoid computational errors, $\Delta Y(TP)$ must be limited so that the carriage does not rise above the skyline chord, and $\Delta T1MAX$ must be limited so that skyline tensions remain positive. It is possible to restrict the increment on either one or both parameters.

2.4.4 Force on the Intermediate Support

Once all segment forces are known, the force components acting on the intermediate support jack, FRIGHTIS and FDOWNIS, can be found from equations of horizontal and vertical equilibrium at the jack. Referring to the force diagram of Fig. 4:

$$\Sigma F_{hor} = 0 \text{ or } FH1 - FHU - FRIGHTIS = 0 \quad [24]$$

$$\Sigma F_{vert} = 0 \text{ or } VURT - V1LT + FDOWNIS = 0 \quad [25]$$

where:

ΣF_{hor} = the sum of horizontal forces acting on the intermediate support jack,

- ΣF_{vert} = the sum of vertical forces acting on the intermediate support jack,
- FH1 = the horizontal component of cable tension T1LT,
- FHU = the horizontal component of cable tension TURT,
- VURT = the vertical component of cable tension TURT,
- V1LT = the vertical component of cable tension T1LT,
- FRIGHTIS = horizontal component of the reaction force acting rightward on intermediate support, and
- FDOWNIS = vertical component of the reaction force acting downward on intermediate support.

2.4.5 Height of Mainline Above Ground

The height of the mainline above the ground is computed at every terrain point from the carriage back to the headspar. The lowest clearance and the terrain point at which it occurs is reported. This information shows the relative effectiveness of the multispan system in preventing mainline drag. The model reports negative mainline clearance to reflect the mainline dragging on the ground.

The computation for mainline clearance is based on Eqn. [13]. D , in this case, refers to the horizontal distance from the carriage to the point where clearance is being computed, and HY is the elevation gain of the mainline from the carriage to that point.

This relatively simple procedure was developed specifically for this model and apparently is not used in other skyline analysis models.

2.4.6 Likelihood of Jack Passage

Brantigan (1978) showed that the likelihood of the carriage passing the jack successfully is related to the tensions in the skyline and the mainline. Brantigan's hypothesis states that if the skyline tension is low enough that the carriage can rest in equilibrium directly below the jack, then jack passage is unlikely, regardless of the direction of pull of the mainline (angle ALPHA in Fig. 5). In this condition, the angle of the skyline to the horizontal, THETAJ , equals 90 degrees.

Some difficulties exist in applying this criteria to predict jack passage in the current model. First, it appears that excluding the angle of action of the mainline from the jack passage criteria may be an oversimplification. Also, the carriage location at the time tensions and angles are measured significantly affects the result, but there is no standard for carriage location. As the carriage approaches the jack, skyline tension drops and mainline tension rises rapidly. The carriage location used in Brantigan's analysis is not readily applied to this model because:

- 1) The model used by Brantigan sampled tensions with the carriage 0.1 foot from the jack, and the squirrel carriage model is unable to obtain convergence for many profiles with the carriage so close to the jack, and

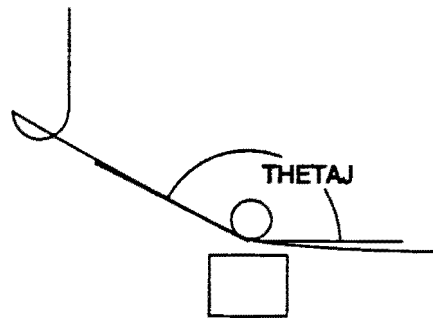

Larger skyline angle THETAJ indicates better chance for successful jack passage.

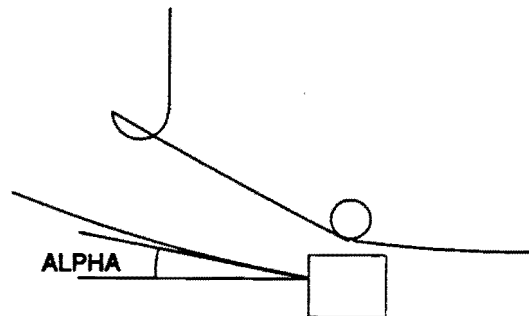

Higher angle of mainline pull, ALPHA, increases chance of successful jack passage.

Figure 5. Jack passage parameters

2) The model used by Brantigan found the vertical carriage position using the elliptical load path and rigid link assumptions, while I find the vertical carriage position using the unstretched skyline length and catenary assumptions. With the carriage very near a support, the two methods give very different results.

Therefore, rather than implement a modification of Brantigan's criteria, I compute and report angles THETAJ and ALPHA with the carriage 10 horizontal feet beyond the jack as a relative measure of likelihood of jack passage. At terrain points very near the jack, higher values of THETAJ (approaching 180 degrees) and higher values of ALPHA (approaching 90 degrees) indicate better prospects of jack passage success.

2.5 Payload Analysis of Compound Jack System

The analysis method for the compound jack system is very similar to the method used for the conventional system. While the compound jack system model apparently is unique, it uses principles of multiple segment analysis which are frequently used for modelling unusual skyline systems (Sessions, 1986).

When the payload is in the upper span, the compound jack analysis is identical to conventional multispan analysis. When the load is in the lower span, however, the mainline geometry is different. When the load is in the lower span, in the compound jack system analysis, the mainline is divided into two segments (Fig. 6). The forces in segment 4 are found after solving for the horizontal force component by horizontal force equilibrium at the carriage:

$$\Sigma F_{hor} = 0 \quad \text{or} \quad FH2 - FH1 - FH4 = 0$$

[26]

where:

FH1 = the horizontal component of cable tension T1RT, pounds

FH2 = the horizontal component of cable tension T2LT, pounds, and

FH4 = the horizontal component of cable tension T4RT, pounds.

The forces in segment 4 are found using the method previously described for segments with known FH, D and HY.

Compound Jack System
Segment Geometry

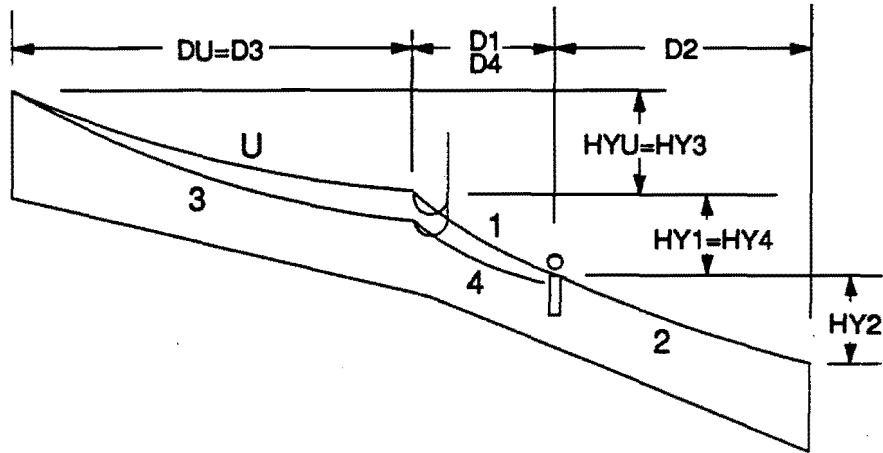

Support Force Free Body Diagrams

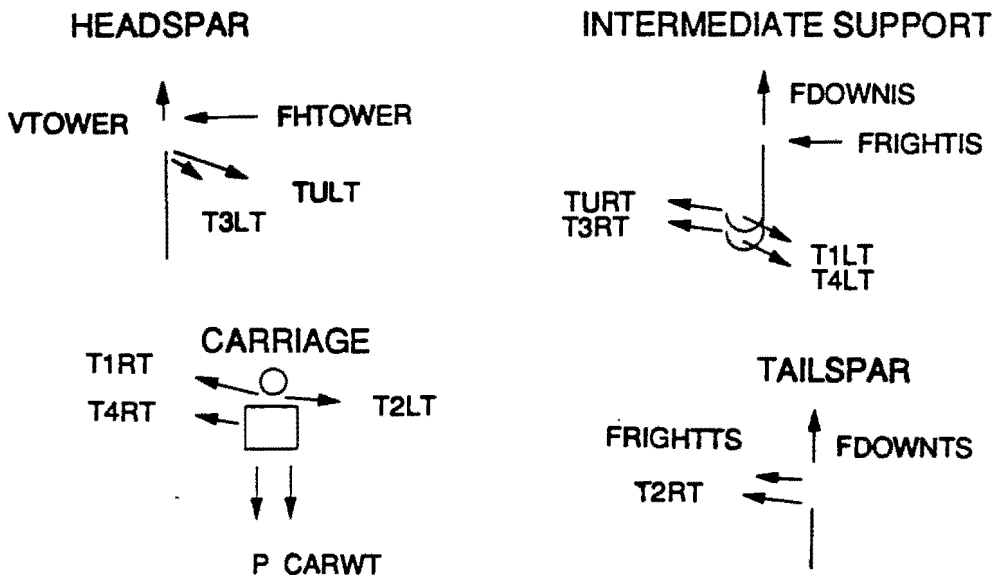

Figure 6. Compound Jack System Geometry and Free Body Diagrams

Friction across the mainline support at the jack is assumed to be negligible, so the lower end tension of segment 3 is equal to the upper end tension of segment 4. The upper end tension of segment 4 is then found using Eq. [5] and segment 4 forces are computed by the method used before for segments where TUP, D and HY are known. Stretch computations are not performed for segments 3 and 4, as the unstretched length of the mainline is not of interest.

The net payload computation is based on the equation of vertical equilibrium at the carriage:

$$\Sigma F_{vert} = 0 \text{ or } V1RT + V4RT - V2LT - CARWT - P = 0 \quad [27]$$

where:

V1RT = vertical component of cable tension T1RT, pounds,

V2LT = vertical component of cable tension T2LT, pounds,

V4RT = vertical component of cable tension T4RT, pounds, and

other variables are as defined previously.

Similarly, the horizontal and vertical components of the force acting down and right on the intermediate support are found from equations of equilibrium at the jack:

$$\Sigma F_{hor} = 0 \text{ or } FH1 - FHU + FH4 - FH3 - FRIGHTIS = 0 \quad [28]$$

$$\Sigma F_{vert} = 0 \text{ or } VURT - V1LT + V3RT - V4LT + FDOWNIS = 0 \quad [29]$$

where all variables are as defined previously.

Computation of mainline clearance requires separate analyses for segments 3 and 4, but the method is the same as for the conventional multispan system system.

2.6 Payload Analysis of Squirrel Carriage

The squirrel carriage model is an original procedure developed during this research project. The difficulty in the analysis, compared to the conventional multispan analysis, is due to two additional unknowns, the squirrel carriage horizontal position (SQX) and vertical position (SQY). The horizontal and vertical force balance at the squirrel carriage provide the two new equations needed to solve for the two additional unknowns. The general approach to solving the problem is to:

- 1) Assume the skyline maximum tension, T1MAX, and the squirrel carriage coordinates, SQX and SQY.
- 2) Solve the multi-segment problem for the assumed geometry letting unbalanced forces accumulate at the squirrel carriage.
- 3) From the unbalanced forces estimate a new squirrel carriage position for the next iteration, and return to step 2.

The procedure is shown in more detail in the flowchart of Fig. 7.

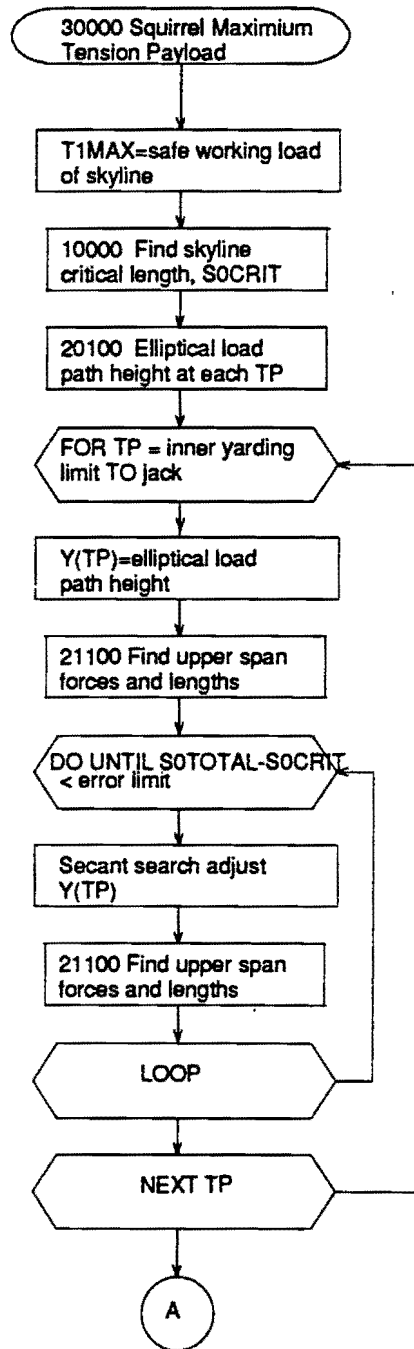

Figure 7. Squirrel carriage subroutine flowchart.

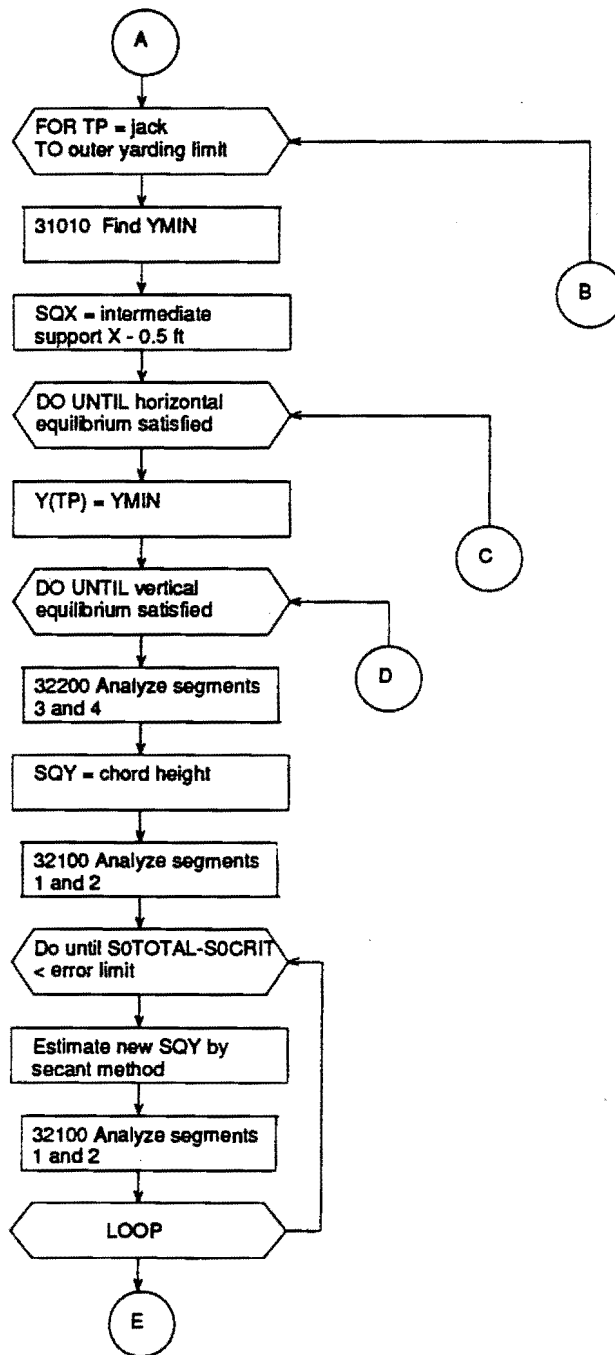

Figure 7. Squirrel carriage subroutine flowchart, continued.

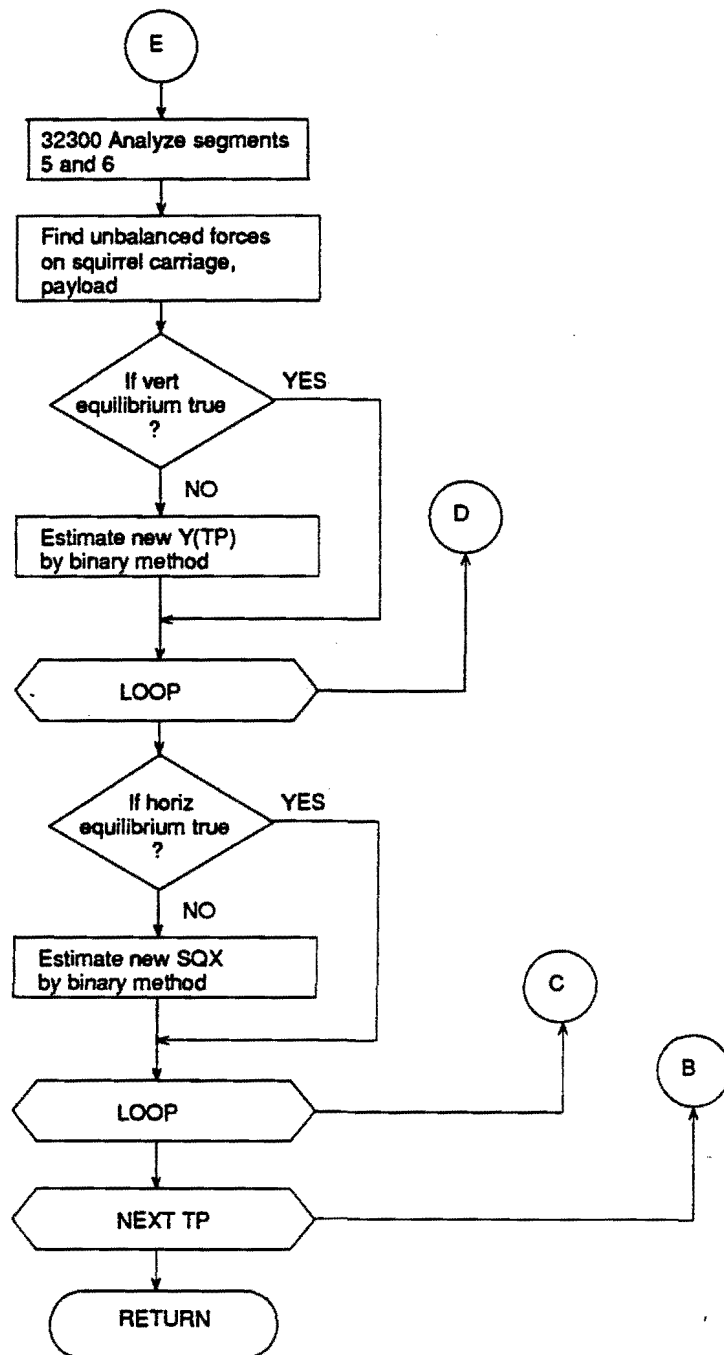

Figure 7. Squirrel carriage subroutine flowchart, concluded.

The squirrel carriage model describes the performance of the system when the load is in the lower span. While the carriage is in the upper span, the squirrel carriage rolls out with the carriage in outhaul and is brought in with it in inhaul (neglecting dynamic effects). The conventional multispan analysis can be used for the upper span, therefore, except that the squirrel carriage weight is deducted from the gross payload to find the net payload.

2.6.1 Unstretched Skyline Length

The unstretched skyline length, SOCRIT, for the squirrel carriage system is computed as in conventional multispan analysis. This length is not strictly accurate for the squirrel carriage system, because the squirrel carriage pulls down on the skyline in the upper span and the carriage is therefore slightly higher in the second span. The carriage clearance produced by this method is always slightly higher than specified in the input, but the difference is generally small (for example, .08 foot in the "standard case" described in Section 3). It is not possible to solve directly for SOCRIT corresponding to a specified carriage clearance since the squirrel carriage position is initially unknown. An iterative search could be used to find SOCRIT for the exact carriage clearance, but the computational effort is probably not warranted given the magnitude of the error.

2.6.2 Forces for a Given Geometry and Tension

For a given upper end skyline tension and system geometry, the forces and lengths are computed according to the forces and geometry shown in Fig. 8. Given or assuming the maximum skyline tension and the carriage and squirrel carriage location, TUP, D, and HY are known for segments 1, 2, 3 and 4. Solution for all forces and unstretched length of these segments follows as before. The horizontal force component in segment 6 is then found from horizontal force equilibrium at the carriage:

$$\Sigma F_{hor} = 0 \quad \text{or} \quad FH4 - FH3 - FH6 = 0 \quad [30]$$

Then FH, D and HY are known for segment 6 and all segment forces and lengths can be determined. The lower end tension of segment 5 is taken to be equal to the upper end tension of segment 6. Then the upper end tension of segment 6 is found using Eqn. [2] and segment 5 forces can be computed given TUP, D and HY.

Squirrel Carriage System

Segment Geometry

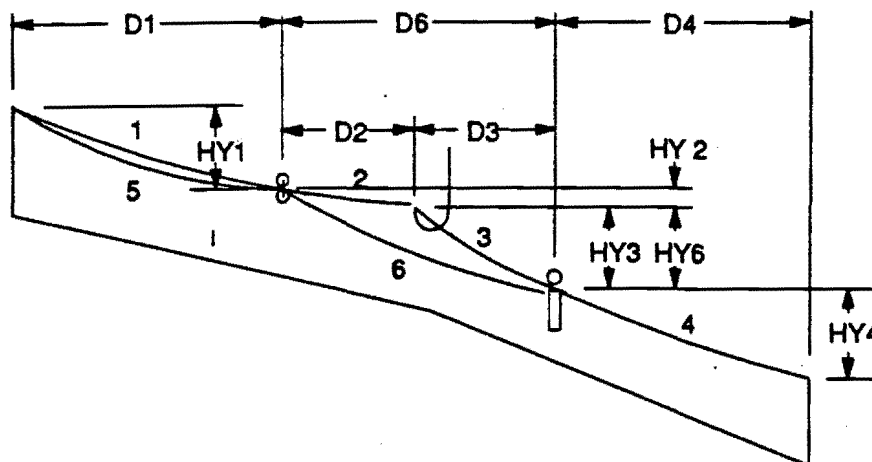

Support Force Free Body Diagrams

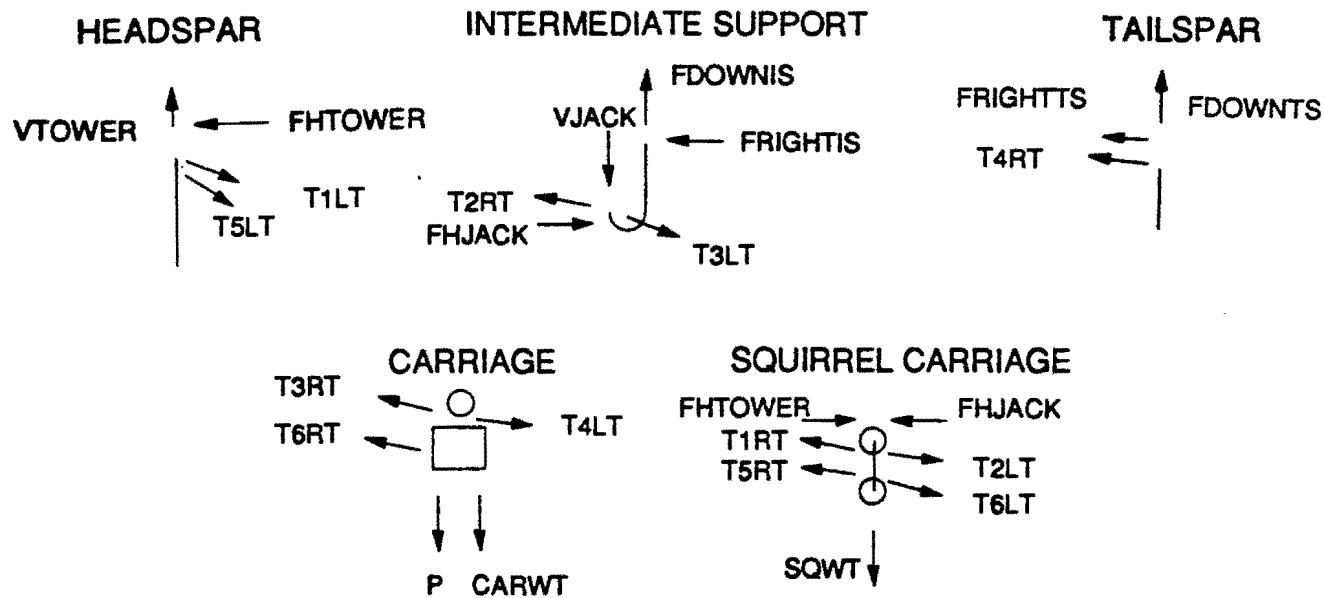

Figure 8. Squirrel carriage geometry and free body diagrams

The net payload is computed using the vertical force equilibrium at the carriage:

$$\Sigma F_{\text{vert}} = 0 \text{ or } V3RT - V4LT + V6RT - CARWT - P = 0 \quad [31]$$

Note that in this sequence of segment analyses, horizontal and vertical force equilibrium at the carriage are guaranteed by Eqs. 30 and 31, but there is no guarantee that forces acting on the squirrel carriage are in equilibrium. In any case where the assumed squirrel carriage coordinates are not the equilibrium position, there will be an unbalanced resultant force against the squirrel carriage. The horizontal component of the resultant force acting to the right on the squirrel carriage, RX, is found from the horizontal force balance equation at the squirrel carriage:

$$RX = FH2 + FH6 - FH1 - FH5 - FHJACK + FHTOWER \quad [32]$$

where:

FHJACK = horizontal force of jack acting leftward against squirrel carriage, in pounds, if the squirrel carriage is at the jack, and

FHTOWER = horizontal force of tower acting rightward against squirrel carriage, in pounds, if the squirrel carriage is at the headspar.

The jack and headspar are able to apply a practically unlimited resisting force against the squirrel carriage when the squirrel carriage is at rest against either support, and the cable forces are pushing it toward the support.

The vertical component of the resultant force acting upward on the squirrel carriage, RY, is found from the vertical force balance equation at the squirrel carriage:

$$R_Y = V_{1RT} + V_{5RT} - V_{2LT} - V_{6LT} + V_{JACK} - V_{TOWER} - SQWT \quad [33]$$

where:

V_{JACK} = vertical force of jack acting upward against squirrel carriage, in pounds, if squirrel carriage is at the jack,

V_{TOWER} = vertical force of tower acting downward against squirrel carriage, in pounds, if squirrel carriage is at the headspar, and

$SQWT$ = the weight of the squirrel carriage.

The vertical reactions of the jack and tower, again, are expected to be as large as necessary to keep the squirrel carriage at rest if the squirrel carriage is being pushed against the support.

2.6.3 Squirrel Carriage Horizontal Location

The model searches for the squirrel carriage horizontal location, SQX , which results in horizontal equilibrium at the squirrel carriage, or $R_X = 0$.

Since the function $R_X = f(SQX)$ is poorly behaved, secant or gradient searches for SQX are not generally successful (see Fig. 11). Instead, a binary search is used. The initial guess for SQX is the position at rest against the jack, which is taken to be 0.5 feet to the left of the jack. This frequently is the equilibrium position, in which case no iterations are required.

For a given SQX, the carriage height, Y(TP), is found which satisfies vertical equilibrium requirements. For the assumed SQX and Y(TP), the model computes the horizontal resultant on the squirrel carriage, RX. If $RX > 0$, then the squirrel carriage is being pushed into the jack by the cable forces and, it is at rest at the jack. If $RX < 0$, then the cable forces are pushing the squirrel carriage to the left and a new SQX is estimated to the left of the current estimate of SQX. When RX is sufficiently close to zero, the payload and all forces and lengths are reported according to the method described above. A tolerance of one pound in the horizontal resultant is reasonable.

2.6.4 Search for Carriage Height

For any given SQX, the model searches for the carriage height, Y(TP), which results in vertical equilibrium at the squirrel carriage, or $RY = 0$. For each trial value of Y(TP), the squirrel carriage height is found and RY is computed. If RY is not sufficiently close to zero, a new Y(TP) is estimated and RY is computed again. The search for Y(TP) is a secant search routine nested within the search for SQX.

To avoid computational errors, the search routine must limit estimates of Y(TP) within a feasible region. For an excessively low Y(TP) it is impossible to obtain the correct unstretched skyline length. For excessively high values of Y(TP), mainline tension becomes negative. This search procedure is not successful in finding the maximum feasible Y(TP) to the degree of precision needed on some profiles, for example long profiles with low payloads.

2.6.5 Search for Squirrel Carriage Height

The squirrel carriage height, SQY, is found by a secant search nested within the search for Y(TP). SQY must be the height which results in the unstretched skyline length equal to the specified length, SOCRIT. The lengths of segments 3 and 4 are computed for the given Y(TP). Then the lengths of segments 1 and 2 are computed for each trial SQY until the total of the unstretched lengths of segments 1 through 4 is sufficiently close to SOCRIT.

2.6.6 Mainline Tension Check

When a solution has been found satisfying static equilibrium, the model checks the maximum mainline tension. If the mainline tension exceeds the specified safe working load, the model finds a new equilibrium solution in which the maximum mainline tension approximately equals the mainline safe working load. The model varies the maximum skyline tension, T1MAX, in a secant search until the desired result for mainline tension is obtained.

2.6.7 Load Path

The squirrel carriage load path analysis uses a secant search at each terrain point varying T1MAX until the desired payload is obtained. The procedure is virtually identical to the mainline tension reduction procedure, but payload rather than mainline tension is used as the dependent parameter in the search.

2.6.8 Forces on the Intermediate Support

The horizontal and vertical components of the force acting down and right on the intermediate support are found from equations of equilibrium at the jack:

$$FRIGHTIS = FH3 - FH2 + FHJACK \quad [34]$$

$$FDOWNIS = V3LT - V2RT - VJACK \quad [35]$$

where:

$FRIGHTIS$ = horizontal component of reaction force acting rightward on the intermediate support, and

$FDOWNIS$ = vertical component of reaction force acting downward on the intermediate support.

2.6.9 Mainline Ground Clearance

Clearance of the mainline above the ground is computed in the same manner as described for the compound jack system, but the mainline segments in this case are from carriage to squirrel carriage and from squirrel carriage to headspar.

3. LOGGING PERFORMANCE PREDICTIONS UNDER VARYING CONDITIONS

The model was used to predict the performance for all three types of multispan systems under a range of conditions. Performance was measured in terms of the maximum net payload which could be yarded from the outer yarding limit, minimum mainline clearance, and the indicators of successful jack passage, angles THETAJ and ALPHA. In general, the predicted performance of the compound jack system is the best, and the performance of the conventional system is the worst. The performance of the squirrel carriage system ranges between the performance of the other two systems.

For the purpose of comparison of the major aspects of performance, each system was tested on a typical ground profile with yarder parameters for a Madill 071 yarder and a typical rigging configuration. This profile is referred to as the standard profile. For simplicity, the profile was designed as two chords with an intermediate support located at the break in slope. The slope of the upper chord is specified directly, and the break in slope is specified to define the lower chord slope (Table 1, Fig. 9). A sample output for the standard profile is given in Appendix B.

Table 1. Standard Profile, Setting and Yarder

Table 1A, General Data

Total horizontal span distance:	800 feet
Ratio (upper span)/(total span):	0.5
Ground slope in upper span:	-40%
Break in slope at intermediate support:	5 degrees
Minimum Carriage Clearance:	15 feet
Logs suspension:	total suspension
Yarder name:	Madill 071
Headspare height:	49 ft.
Carriage weight:	1500 lb.
Carriage depth:	0 ft.
Squirrel carriage weight:	200 lb.

Table 1B, Profile Data

TP	Horizontal Distance (ft)	Vertical Distance (ft)	Point Description	Skyline height (ft)
1	0.00	1000.00	headspare	49
2	80.00	968.00	inner yarding limit	
3	160.00	936.00		
4	240.00	904.00		
5	320.00	872.00		
6	400.00	840.00	intermediate support	40
7	410.00	834.95		
8	480.00	799.59		
9	560.00	759.17		
10	640.00	718.76		
11	720.00	678.35	outer yarding limit	
12	800.00	637.93	tailspare	40

Table 1C, Cable Characteristics

Line	Dia. (in)	Weight (lb/ft)	Safe Working Load (lb)	Length (ft)	Elastic Modulus (ksi)	Area (sq in)
Skyline	1.000	1.85	34500	1930	12000	0.465
Mainline	0.625	0.72	13700	1885	12000	0.182

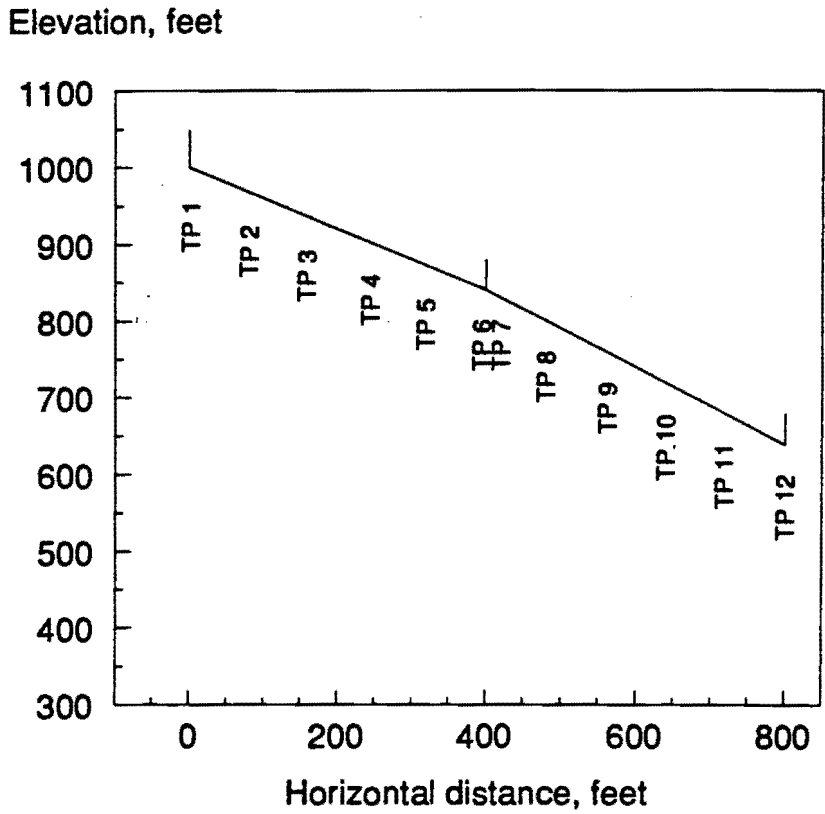

Figure 9. Standard profile showing terrain points and intermediate spar location.

The effects of key parameters were studied by testing all three systems in different cases. Slope, break in slope, squirrel carriage weight, total horizontal span distance and the ratio of upper span horizontal distance to total horizontal span distance were each varied one at a time. The results using the standard profile follow.

3.1 Payload Capacity

The payload capacity of the three systems varied as shown in Table 2. The squirrel carriage payload, 5843 lbs., exceeds the conventional system payload by 5.5% and the compound jack payload, 6043 lbs., exceeds the conventional system payload by 9.1%. The advantage of the two suspended mainline systems comes from the higher vertical component of mainline pull on the carriage in the lower span.

In the conventional multispan system, the critical terrain point lies in the middle of the lower span, while the critical terrain point lies in the middle of the upper span for the two suspended mainline systems. In the squirrel carriage and compound jack systems, the angle of mainline pull is higher when the load is in the lower span, increasing payload capacity in the lower span. While the load is in the upper span, the payload capacity is identical for the conventional and compound jack systems.

Table 2. Payload by System Type in Standard Case

System Type	Payload (lb)	Critical TP	Critical Span	Mainline Angle @ TP 9 (degrees)
Conventional	5537	9	lower	22.6
Compound	6043	4	upper	32.5
Squirrel	5843	4	upper	31.2

The increase in the vertical component of the mainline tension is shown by the values for the mainline angle from horizontal in Table 2. The squirrel carriage achieves a slightly lower angle of pull than the compound jack system because the squirrel carriage location is approximately 20 feet upslope from the jack in this case.

The difference between the squirrel carriage payload and the compound jack payload is exactly the weight of the squirrel carriage, which is assumed to rest against the carriage in the upper span and contribute to the gross payload.

3.2 Mainline Clearance Above Ground

As expected, suspending the mainline also improves the clearance of the mainline above the ground (Table 3).

Table 3. Mainline Clearance by System in the Standard Case, 5537 lb Net Payload

SYSTEM TYPE	MIN. MAINLINE CLEARANCE, ft	CRITICAL CLEARANCE TP	CARRIAGE LOCATION TP
Conventional	-4.5	6	11
Compound	22.3	9	10
Squirrel	22.2	9	10

The model predicts that the conventional multispan system would result in dragging of the mainline at the break in slope, terrain point 6. The two systems suspending the mainline, however, should provide enough lift to keep the mainline at least 22 feet off the ground at all times. The slight difference in clearance between the compound jack and squirrel carriage systems is the result of the squirrel carriage being located 0.5 feet upslope from the jack.

The improvement of mainline clearance is significant and is found in all cases tested.

3.3 Carriage Passage over the Jack

The indicators of successful jack passage show a small improvement from suspending the mainline. Table 4 displays the two relative measures of the likelihood of jack passage, THETAJ and ALPHA, for the standard case and a net payload of 5537 pounds when the carriage is located 10 feet downslope from the jack.

Table 4. Jack Passage Indicator Angles by System in the Standard Case

SYSTEM TYPE	SKYLINE ANGLE THETAJ, degrees	MAINLINE ANGLE ALPHA, degrees
Conventional	136.6	21.5
Compound	139.1	40.9
Squirrel	138.0	31.6

While the model does not attempt to predict successful jack passage, these results indicate that there is a potential for significant improvement with the suspended mainline systems.

There is a dramatic improvement in the angle of pull of the mainline using the compound jack system, but the gain must be considered only a potential for improvement of actual jack passage until experiments are performed with actual full-scale jacks. Some factors complicating the jack passage problem with this system are:

- 1) The mainline must lift out of the support just before the carriage passes the jack,
- 2) The mainline may be attached to the carriage at an offset from the vertical line below the skyline sheave, applying a slight twisting torque to the carriage, and
- 3) The sway of the jack may be affected by the mainline support.

3.4 Location of the Squirrel Carriage

The static equilibrium location for the standard case and 5537 pound payload is

shown graphically in Fig. 10. The squirrel carriage rests against the jack when the carriage is at the bottom of the lower span, moves away from the jack as the carriage comes up to midspan, and moves back down toward the jack as the carriage approaches the jack.

Though the static equilibrium squirrel carriage position approximates the position the squirrel carriage would take during a very slow yarding cycle, during normal yarding the squirrel carriage might rapidly accelerate toward the headspar and roll back downslope very slowly. The magnitude of the force which would be applied during load pickup can be inferred from Fig. 11.

The vertical axis of Fig. 11 shows the horizontal force which would be applied against the squirrel carriage when the squirrel carriage is at the horizontal position shown on the horizontal axis. The horizontal position where the curve crosses zero pounds is the equilibrium horizontal position for the given payload. The equilibrium horizontal position for the empty carriage would be to the right of equilibrium position for a loaded carriage.

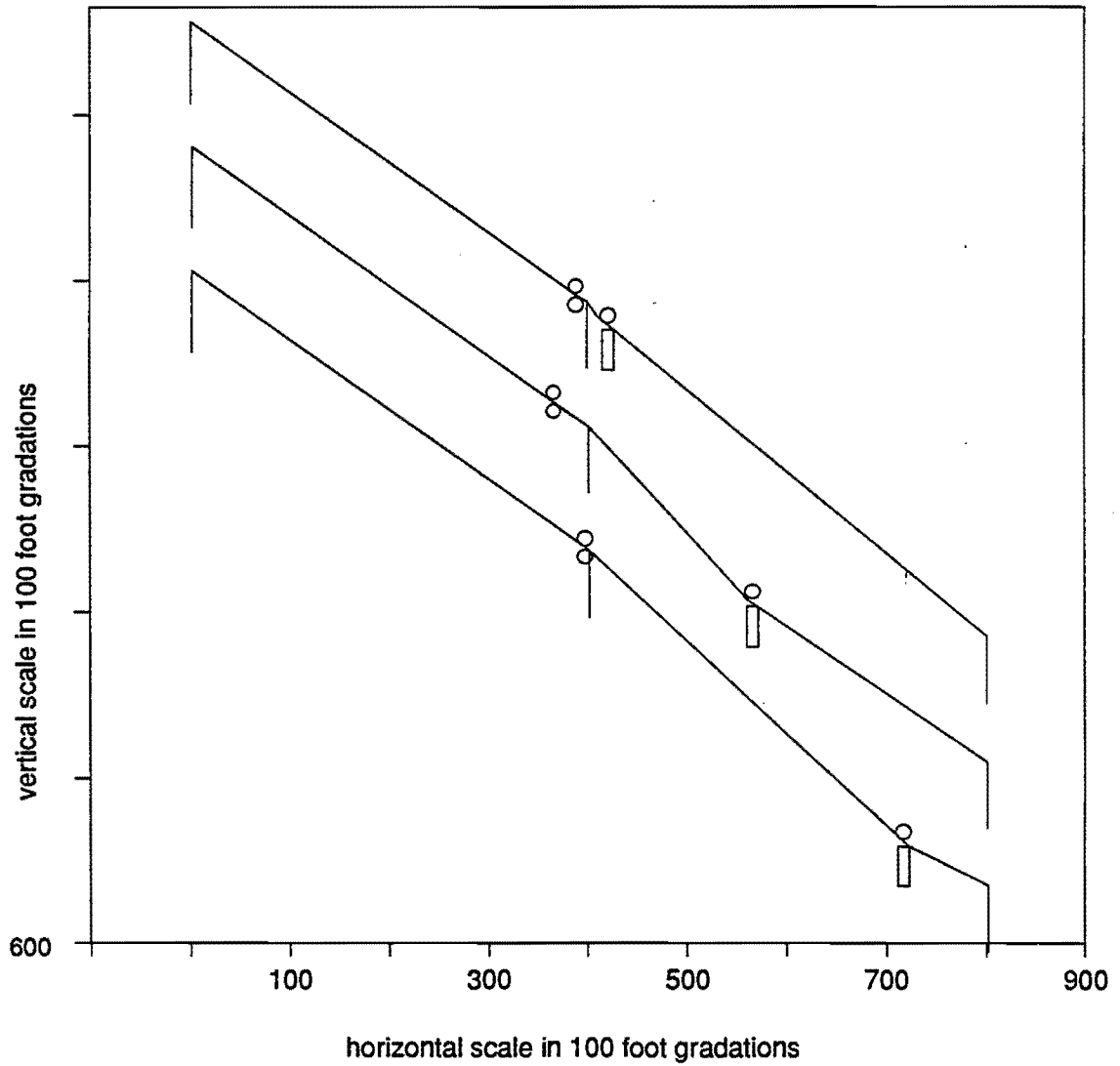

Figure 10. Squirrel carriage location, standard case. Three views of the standard profile, showing the carriage in different locations and the corresponding equilibrium squirrel carriage positions. Net payload is 5537 pounds.

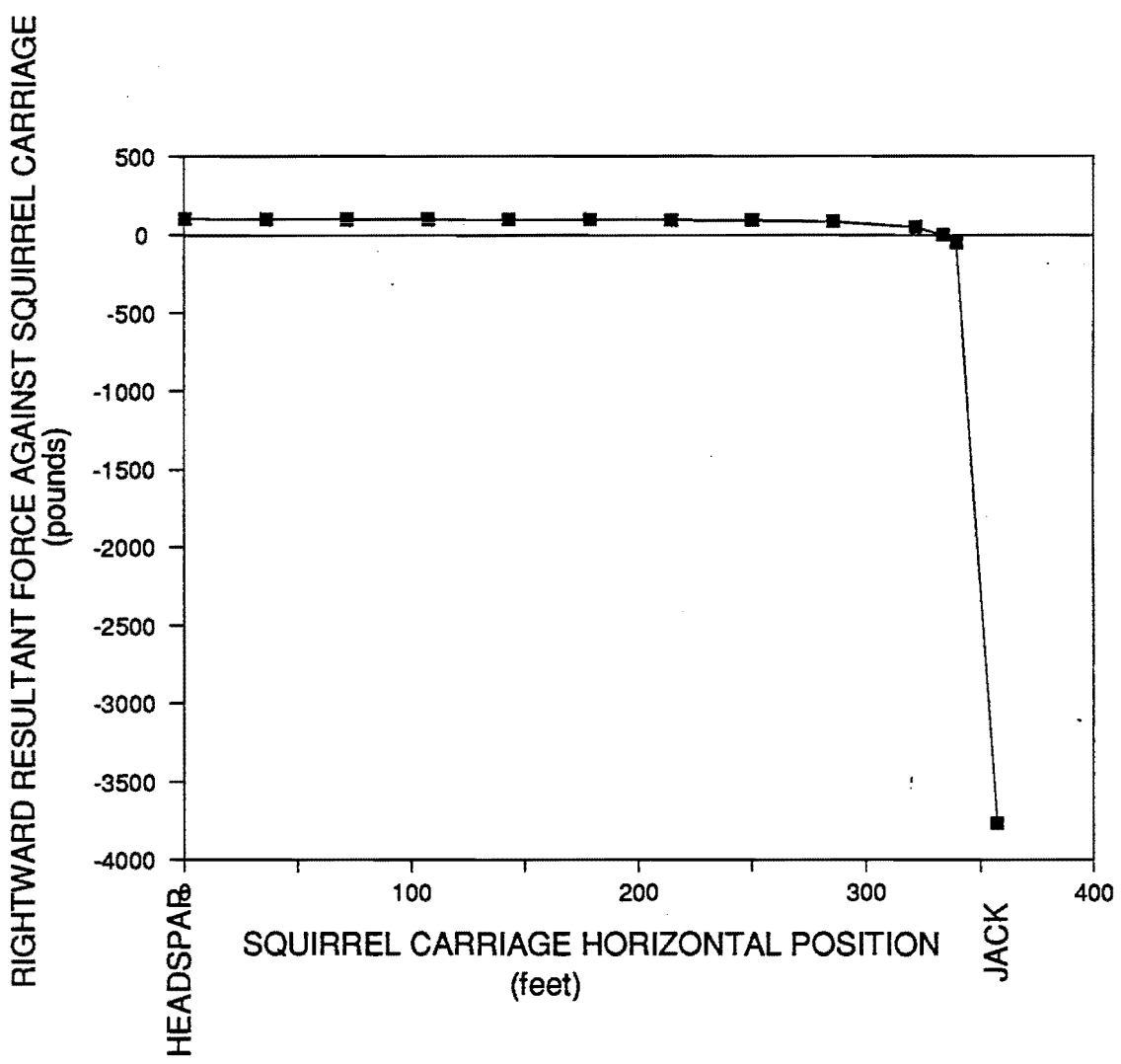

Figure 11. Horizontal force on squirrel carriage. The vertical axis shows the resultant horizontal force against the squirrel carriage at the horizontal locations shown on the horizontal axis. For any horizontal location other than the equilibrium position, this is equivalent to the horizontal force that would be exerted against a vertical roller holding the squirrel carriage in that location.

Thus, at the time of load pickup, the unbalanced leftward force against the squirrel carriage could be thousands of pounds. After the squirrel carriage had traveled leftward beyond the equilibrium position, however, the unbalanced force returning it to the equilibrium position would be only about a hundred pounds.

Fig. 11 represents a case where the carriage is only one foot from the intermediate support jack, which is an extreme case. When the carriage is closer to the middle of the lower span, the curve retains the same general shape, but the unbalanced leftward forces are lower and the unbalanced rightward forces are higher.

5.5 Force on the Intermediate Support

Table 5 summarizes the maximum force on the intermediate support, in pounds, in the downward, leftward and resultant directions for the standard case and a net payload of 5337 pounds. The change in force on the intermediate support is estimated to be minor for a given payload, as shown in Table 5. The greatest resultant force is generated by the squirrel carriage system, due to the added weight of the squirrel carriage. The increase in force, about 150 pounds or 1.7% over the conventional system, is relatively minor. The compound jack system is expected to actually reduce the force on the jack slightly, probably due to the reduction in line tensions.

Table 5. Force on the Intermediate Support by System in the Standard Case

SYSTEM TYPE	DOWNWARD, lb	TOWARD HEADSPAR, lb	RESULTANT, lb.	% CHANGE
Conventional	7462	4798	8871	0.0%
Compound	7563	4609	8857	-0.2%
Squirrel	7741	4637	9023	1.7%

3.6 Parameter Study

The effects of different yarding parameters on the performance of all three systems was tested by varying the parameters one at a time in the following case studies.

3.6.1 Effect of Ground Slope

The compound jack system maintains superior performance across the range of slopes tested. The squirrel carriage system performance is estimated to nearly equal the compound jack system performance for steeper slopes, but is worse for milder slopes. Figures 12, 13 and 14 display squirrel carriage position as a function of carriage position and slope, and Figures 15, 16 and 17 show the effects of slope on payload, mainline clearance and jack passage indicator angles, respectively.

In this study, the slope of the upper end of the profile is varied directly. The total horizontal span distance and the break in slope between the upper and lower ends of the profile are held constant. Thus, the profiles with greater slope also have greater slope distance and skyline length, which tend to reduce net payload.

Increasing slope tends to move the squirrel carriage lower on the upper span, closer to the jack, as would be expected.

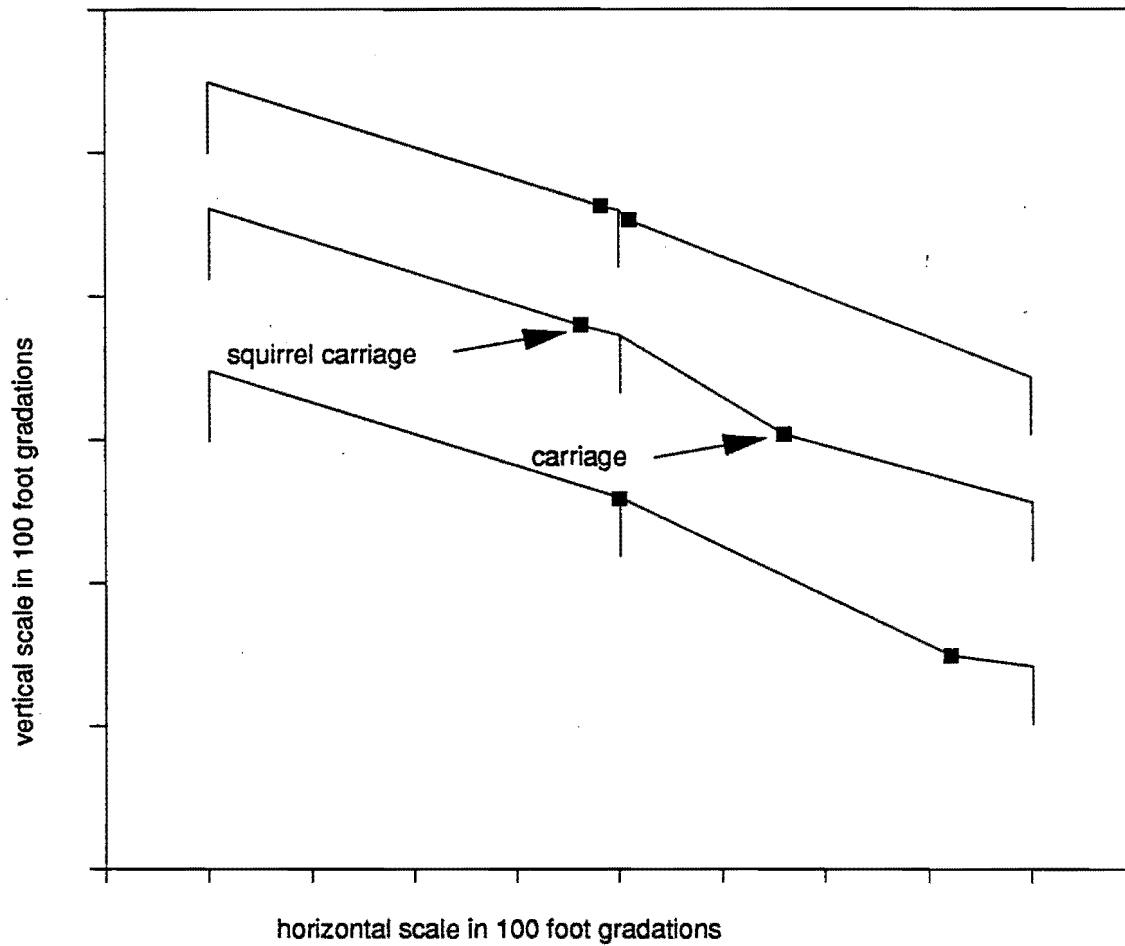

Figure 12. Squirrel Carriage Location, 20% Slope

Equilibrium position of the squirrel carriage with the carriage at terrain points 7, 9 and 11 with 20% slope in the upper span and a 5000 pound net payload. The black square in the lower span represents the carriage location and the black square in the upper span represents the corresponding squirrel carriage equilibrium location.

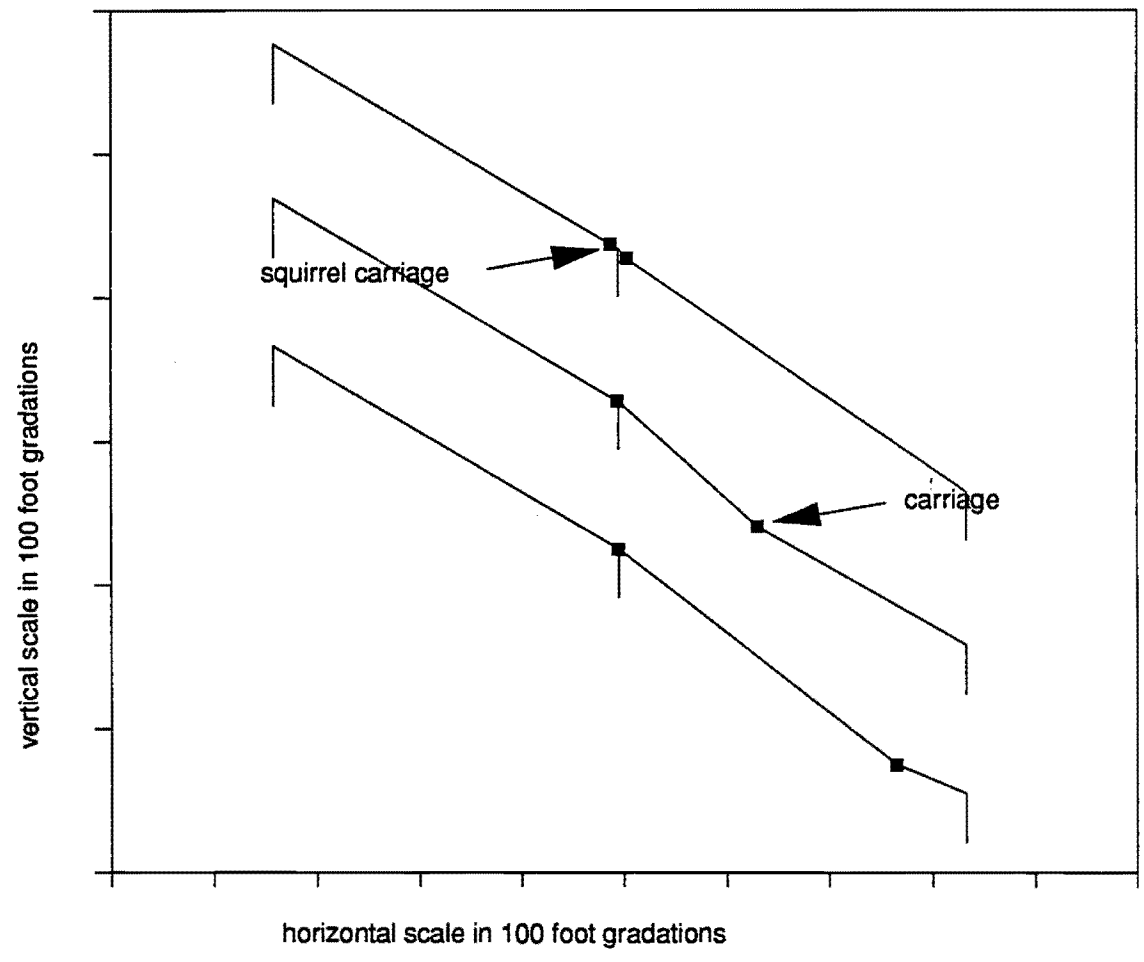

Figure 13. Squirrel carriage location, 40% Slope, 5000 pound net payload.

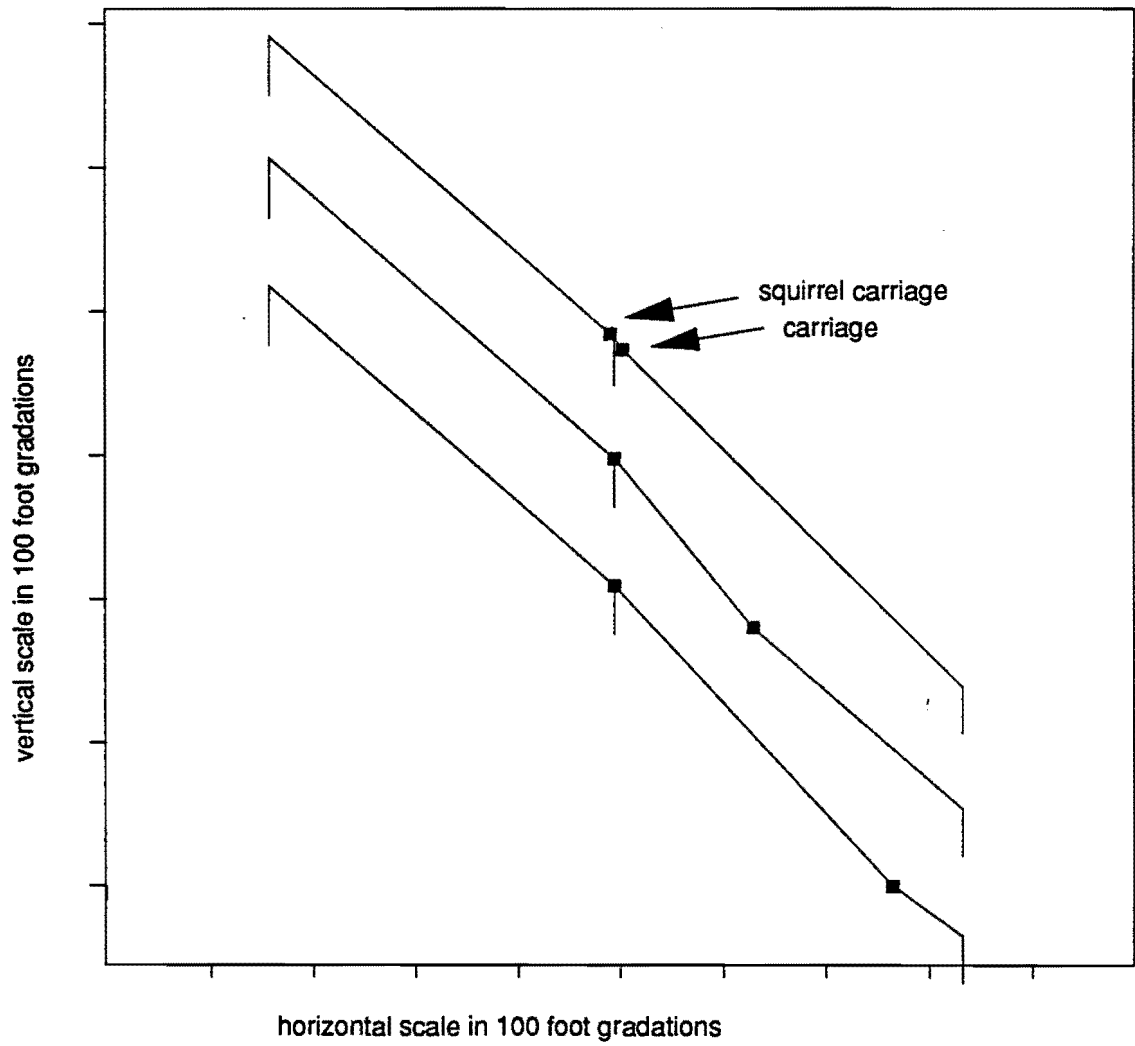

Figure 14. Squirrel carriage location, 60% Slope, 5000 pound net payload.

The payload capacity of the suspended mainline systems benefit from the higher vertical component of mainline pull in each slope range. As in the standard case, the critical terrain point for the conventional system is in the lower span and the critical point for the unconventional systems is in the upper span in each case tested. In each case, the squirrel carriage system payload is less than the compound jack system payload by the weight of the squirrel carriage.

The relative payload disadvantage of the conventional system decreases with decreasing slope. This is due to the decreasing difference in elevation between the headspar and jack, which decreases the difference in the payloads in the upper and lower span.

The compound jack system also provides the best mainline clearance for all slope classes. (See Fig. 16.) The squirrel carriage provides nearly the same mainline clearance except for very mild slopes. On most of the slopes tested, the minimum mainline clearance for both the compound jack and squirrel carriage systems occurred when the carriage was near the end of the lower span at terrain point 10. With the carriage at this point, the squirrel carriage was at rest against the jack for all slopes except 20%. On the 20% profile, the squirrel carriage rolled ahead 30 feet, reducing the lift given to the mainline.

The jack passage indicator angles, THETAJ and ALPHA, likewise are best in all slope classes for the compound jack system, although the relative improvement is small. (See Fig. 17.) Again, the squirrel carriage performs best in the steeper slope classes, where the squirrel carriage remains closer to the jack as the carriage approaches the jack.

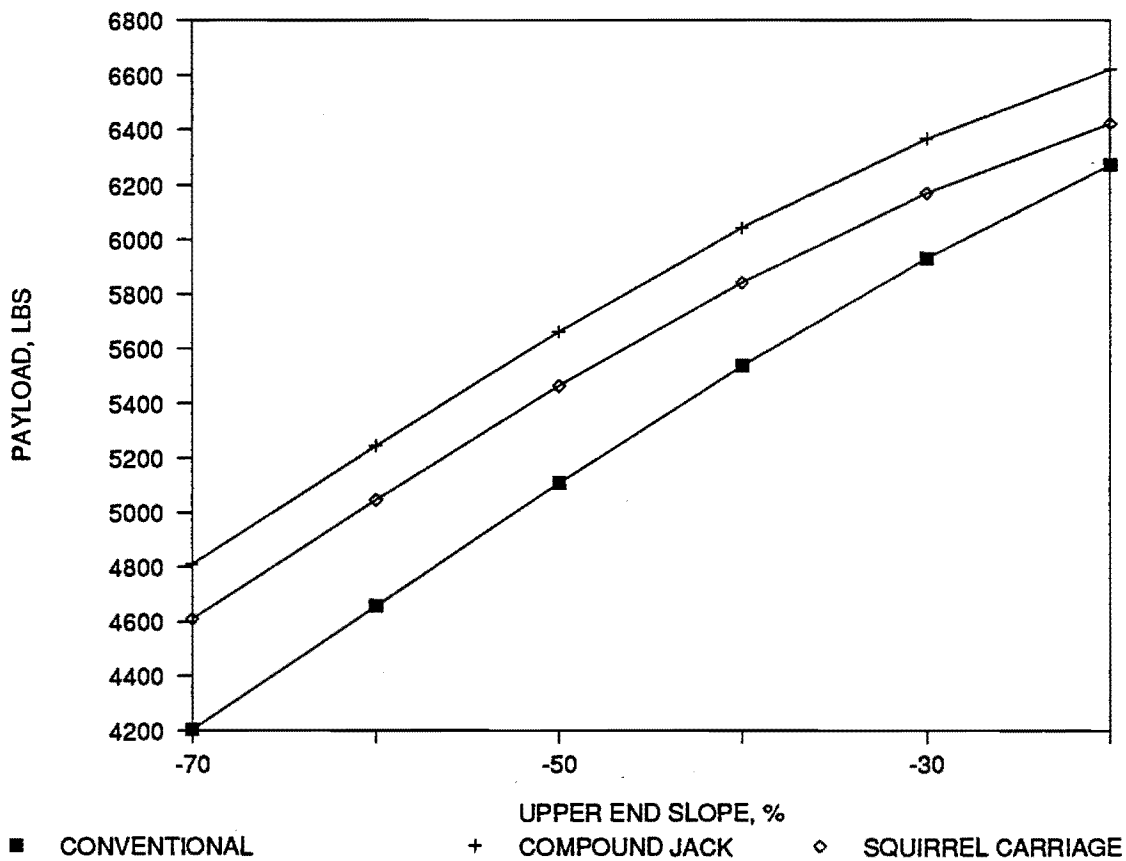

Figure 15. Payload by Slope and System Type. Maximum-to-headspar payloads for varying upper span slope, holding horizontal span length and slope break angle constant.

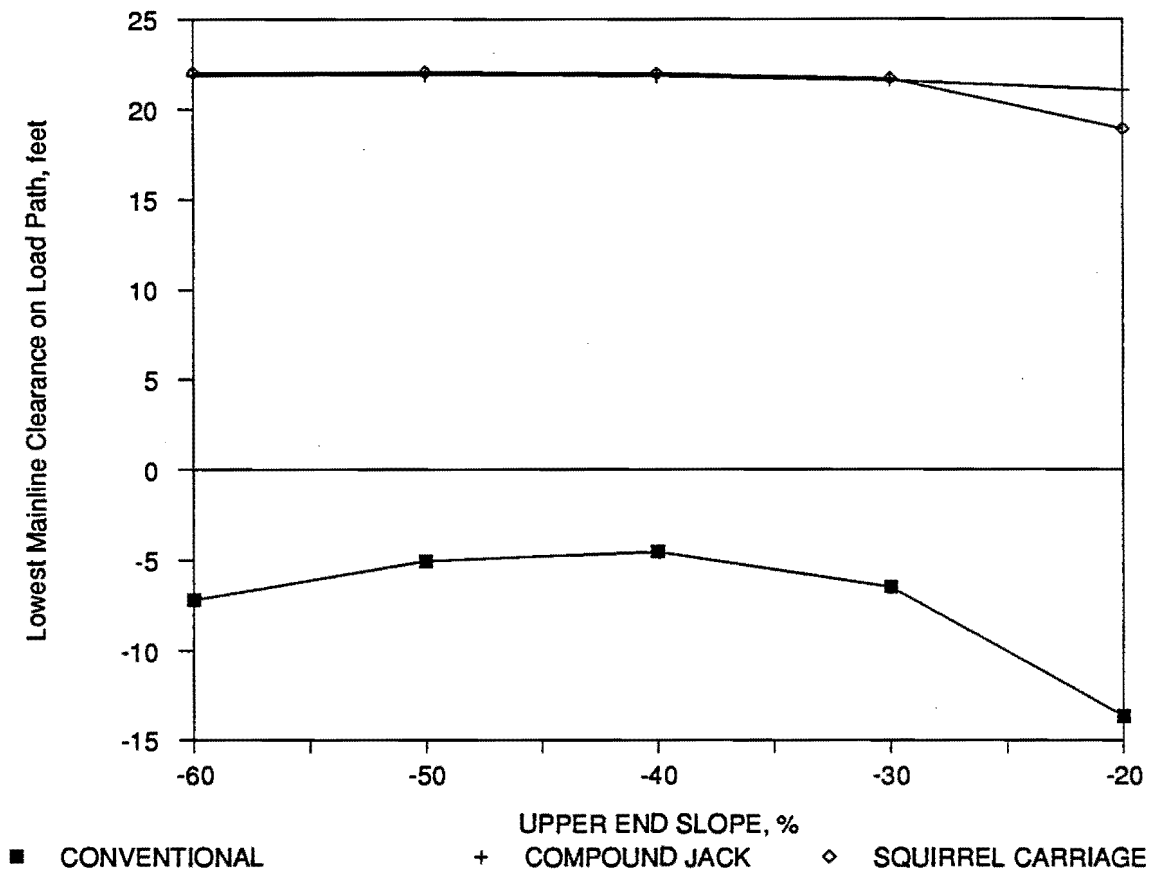

Figure 16. Mainline clearance by slope and system. Minimum mainline clearance for profiles with varying upper end slope. Total horizontal span distance and slope break angle held constant. Net payload at each terrain point is the maximum to headspar payload for the conventional system.

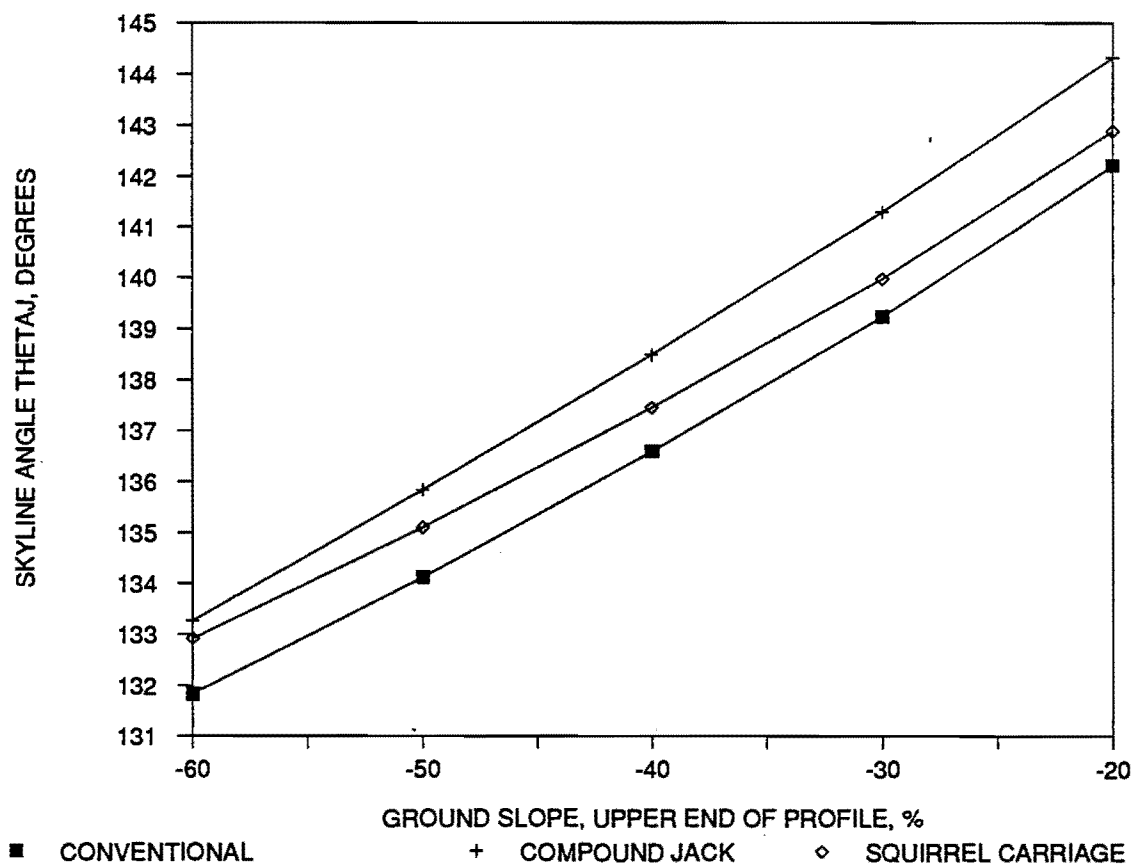

Figure 17. THETAJ by slope and system. Angle THETAJ, the angle between the skyline and the horizontal, measured with the carriage 10 feet below the jack.

3.6.2 Effect of Chord-Slope Break

Larger breaks in slope between the top and bottom of the profile cause the squirrel carriage to travel farther up the skyline. Larger breaks in slope also cause the maximum separation between jack and squirrel carriage to occur when the payload is closer to the tailhold, as seen in Table 6.

Table 6. Horizontal Coordinate of Squirrel Carriage (SQX) by Slope Break

Break in Slope, degrees	SQX with Car. @ TP 7 Near Jack	SQX with Car. @ TP 9 Near Midspan	SQX with Car. @ TP 11 Near Tailspar	Payload, pounds
-2	393	400	400	6528
0	392	400	400	6356
2	390	400	400	6161
4	389	398	400	5952
6	387	370	400	5731
8	385	338	387	5498
10	384	306	325	5228
12	383	275	260	4866

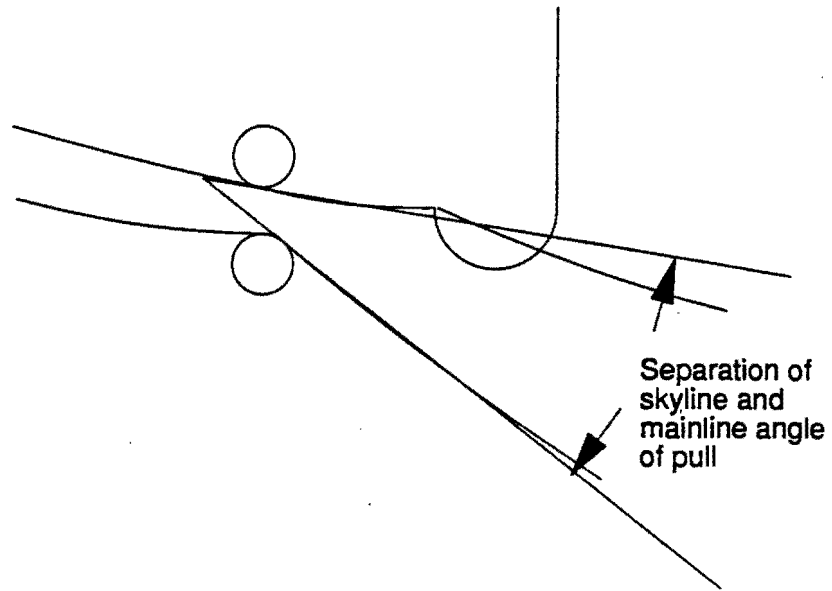

Figure 18. Angle of separation between skyline and mainline. A schematic representation showing the angle between the mainline and skyline and its effect on squirrel carriage movement.

The separation between the jack and squirrel carriage is directly related to the angle between the skyline and mainline below the squirrel carriage (Fig. 18). For large breaks in slope, this angle is greater than for smaller breaks in slope. For large breaks in slope, the angle increases as the carriage approaches the tailspar. Thus, for larger slope break angles, the squirrel carriage is less effective (Fig. 19).

3.6.3 Effect of Squirrel Carriage Weight

The effect of decreasing the squirrel carriage weight is generally to cause the squirrel carriage system to behave more like a conventional multispan system. As shown in Fig. 20, decreasing the squirrel carriage weight from 200 pounds to 100 pounds decreases the maximum to headspar payload from 5843 pounds to 5810 pounds. At the lighter weight, the squirrel carriage moves farther up the skyline when the load is in the lower span. This increased separation between the jack and squirrel carriage results in lower payloads in the lower span. Thus, for the 100 pound squirrel carriage, the critical point is in the lower span. With a heavier squirrel carriage, the lower span payload capacity increases up to the compound jack system payload, but the upper span net payload capacity decreases by the amount of increased squirrel carriage weight. For the cases studied, the optimum squirrel carriage weight is 200 pounds. A higher squirrel carriage weight would be better for a flatter slope or sharper chordslope break.

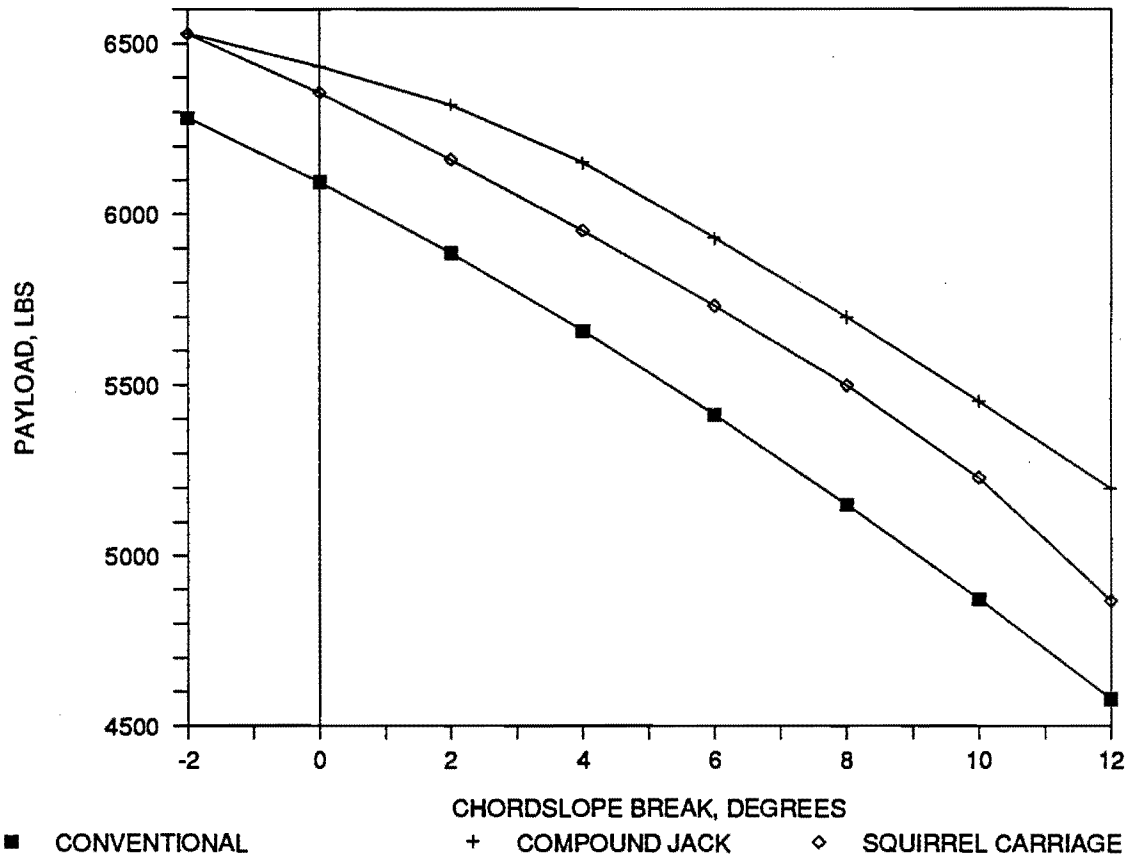

Figure 19. Payload by slope break angle and system. Maximum to headspar payload varying slope break angle, total horizontal span distance held constant.

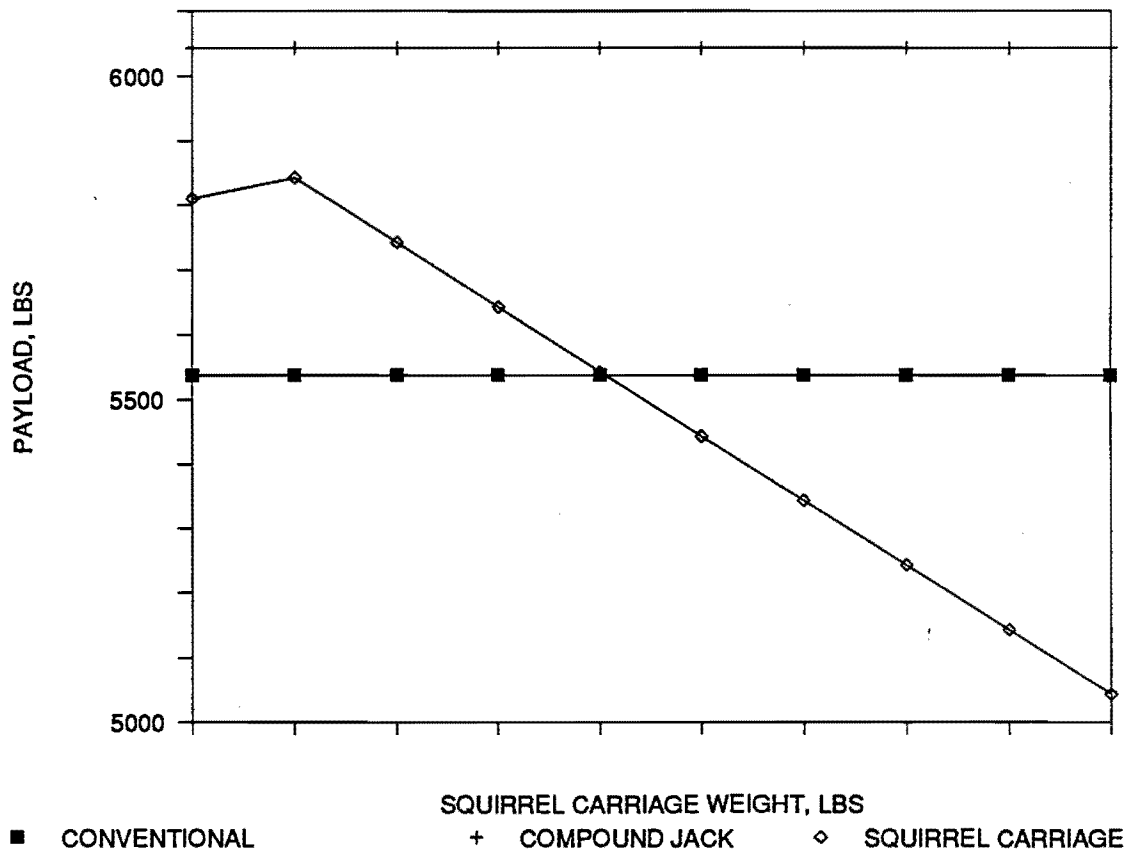

Figure 20. Payload by squirrel carriage weight. Maximum to headspar payload varying squirrel carriage weight, all other parameters held constant.

3.6.4 Effect of Ratio of Upper Span Distance to Total Span Distance

The effect of unequal span lengths was tested by varying the percentage of the total horizontal span distance in the upper span from 40% to 60%. For profiles with relatively long upper spans and short lower spans, the conventional multispan has the same maximum to headspar payload as the compound jack system. In this case, the critical payload occurs in the upper span for all systems.

The squirrel carriage maximum to headspar payload is less than that of the other two systems by the weight of the squirrel carriage in this case. The suspended mainline systems still have much higher mainline clearance than the conventional multispan system in this case, but with a short lower span the problem of mainline dragging decreases.

For profiles with relatively short upper spans, the squirrel carriage maximum to headspar payload nearly equals that of the compound jack system, as the critical payload is in the lower span for all three systems. In this case, the squirrel carriage weight does not detract directly from the net payload, and the squirrel carriage location remains near the jack.

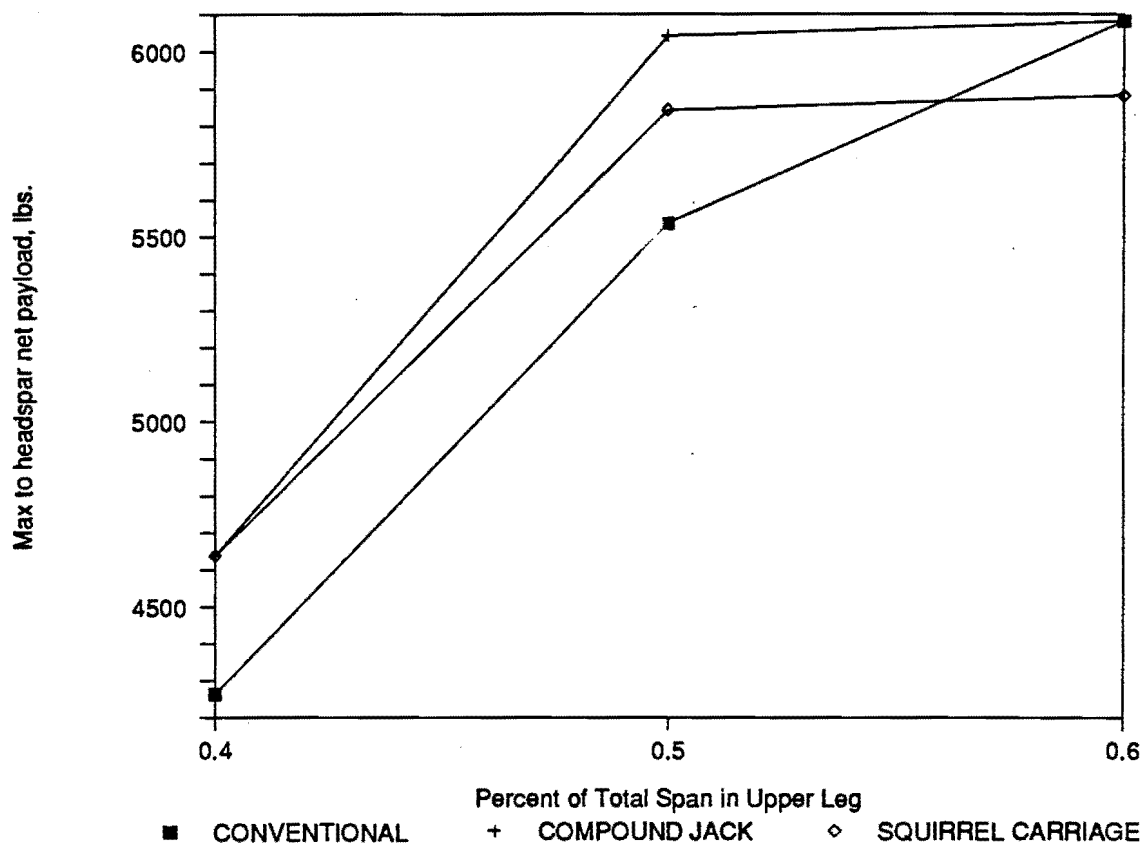

Figure 21. Payload by percentage of total span in upper span

3.6.5 Effect of Total Horizontal Span Distance

In trials varying the total horizontal span distance from 700 to 1100 feet, holding other parameters constant, the compound jack system, and, to a lesser degree, the squirrel carriage system, steadily outperform the conventional system.

In all span length classes tested, the compound jack system maximum to headspar net payload is the highest, followed by that of the squirrel carriage system. In each case, the critical payload for the suspended mainline systems occurs in the upper span and the critical payload for the conventional system occurs in the lower span. The difference in payload between systems remains relatively constant through the range of span lengths.

Mainline clearance also is consistently better for the suspended mainline systems than for the conventional system. On longer spans, mainline dragging worsens for the conventional system.

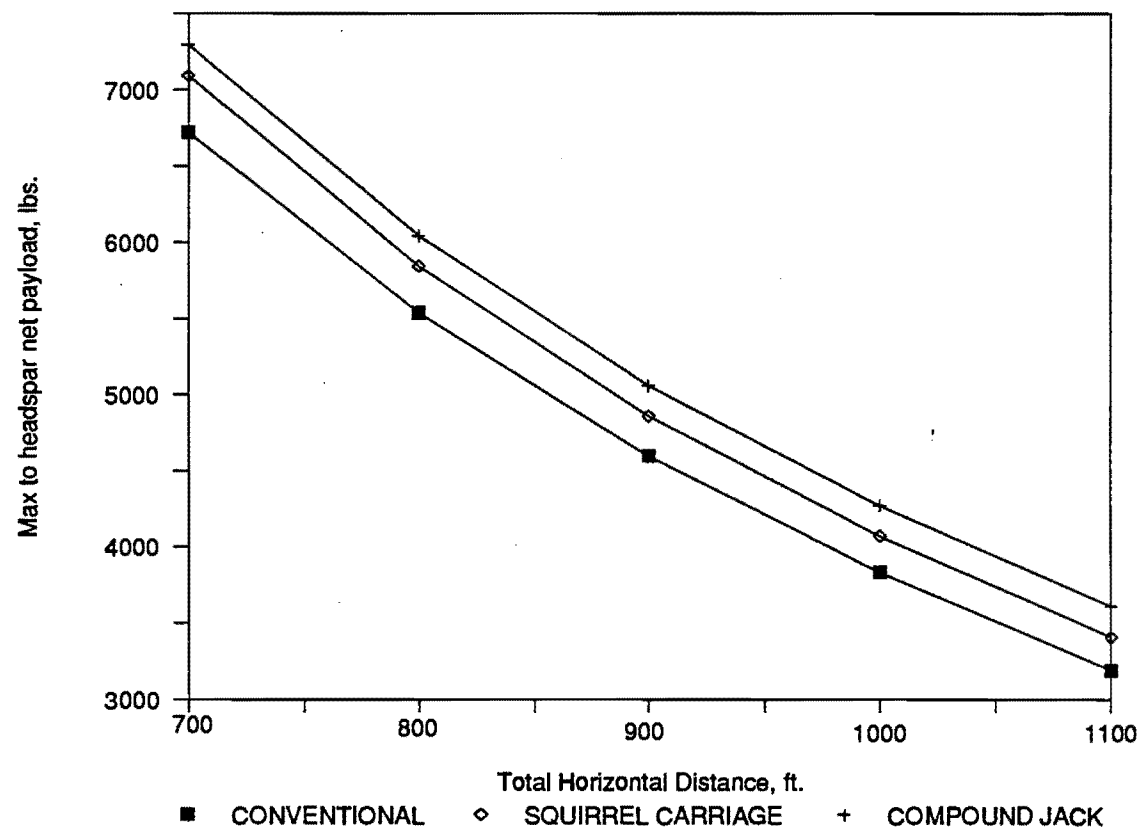

Figure 22. Payload by horizontal span distance.

4. CONCLUSIONS AND RECOMMENDATIONS

4.1 Conclusions

Analysis of three multispan logging systems indicates that there are certain advantages to providing suspension of the mainline. This analysis was performed using an analytical computer model, MULTI, which analyzes static forces under certain simplified conditions. Net payload, suspension of the mainline above the ground and certain indicators of successful carriage passage over the jack were used as measures of performance. The following conclusions are drawn from the results of the analysis.

The compound jack system provides the best estimated performance under all conditions tested. The squirrel carriage system is also estimated to improve performance, although less improvement or no improvement is expected in some conditions.

When the payload is in the upper span, the squirrel carriage described in this model detracts from the net payload and provides no advantage. The compound jack and conventional systems perform exactly the same.

When the payload is in the lower span, either suspended mainline system improves system performance by providing higher payload capacity, greatly reducing the likelihood of mainline dragging, and slightly increasing the likelihood of jack passage. The squirrel carriage provides the greatest advantage when it is positioned at the intermediate support. In this position it performs essentially the same as the

compound jack system. Those conditions which cause the squirrel carriage to roll farther uphill decrease its utility. In the extreme case, if the squirrel carriage were positioned at the headspar, no benefit would be provided at all.

Squirrel carriage position is affected by ground slope, the degree of break in a convex slope and the weight of the squirrel carriage. The squirrel carriage tends to roll uphill from the jack farther for milder ground slopes, for more convex ground slopes and for smaller squirrel carriage weight.

Longer lower spans and longer total spans increase the relative advantages of the suspended mainline systems, since it is in the lower span that the suspended mainline provides lift.

Dynamic forces on the squirrel carriage during operation may cause it to be positioned significantly higher than the static equilibrium location. Dynamic forces are expected to be large when loads are picked up with the carriage just below the intermediate support

4.2 Recommendations

Pending field verification of the results of the mathematical model, the following preliminary recommendations can be made.

For multispan logging profiles, when dragging of the mainline is a problem, or when a marginal improvement in payload in the lower span is desired, the compound jack or squirrel carriage system should be considered.

The squirrel carriage should be considered especially when:

- 1) an inexpensive, easily fabricated system is desired,
- 2) the ground slope is relatively steep,
- 3) the ground slope is not extremely convex, and
- 4) the lower span is longer than the upper span.

5 . FURTHER RESEARCH

Field testing in realistic field conditions is needed to verify and extend the conclusions of this research. While many principles of the performance of the compound jack and squirrel carriage systems can be understood from analysis using the model developed in this thesis, many parameters which are simplified or neglected in the mathematical model would best be studied under field conditions. The effect of dynamics on squirrel carriage position during operation should be studied. For the compound jack system, the potential for lifting of the mainline out of the jack is also an important concern.

The jack passage problem should also be studied further. Jack passage for both the compound jack and squirrel carriage systems should be studied in field testing. For the compound jack system, the effect of the mainline support on jack passage should be observed. The effects of dynamic forces on jack passage should be noted for both systems. The jack passage criteria should also be reviewed at this point, now that more accurate multispan analysis models are available than at the time of Brantigan's research.

Model refinement is needed to achieve convergence of the search routines for long profiles with light payloads. Specifically, development is needed to set the maximum limit in the search for carriage height, $Y(TP)$, to avoid solutions for negative and extremely high mainline tensions.

Other useful refinements and extensions to this model would be to model skyline to jack friction, jack sway, and log drag.

6. REFERENCES

- Anderson, S.H. 1921. Tensions in Track Cables and Logging Skylines, The Catenary Loaded at a Single Point. Bulletin 13. Univ. of Wash. Engr. Exp. Sta., Seattle. 27 p.
- Brantigan, Richard T. 1978. Critical Conditions for Carriage Passage at the Support for Uphill Yarding; MS Thesis; Oregon State University. 111 p.
- Cain, Carl H. and Daniel J. Feeney. 1987. Handbook for Skyline Programs on the Data General; USDA Forest Service, Northern Region; June 1986, revised February 1987. 92 p.
- Carson, Ward W. 1977. Analysis of the Single Cable Segment; Forest Science, Vol. 23, No. 2, pp. 238-252
- Chung, Joosang. 1987. Development of a Cable Logging System Analysis Package for Micro-Computers; MF Paper; Oregon State Univ. 117 p.
- Gonsior, Michael J. 1987. Elastic Cable Analysis Theory; 1987 Winter meeting, American Society of Agricultural Engineers; Chicago, Illinois, Paper No. 87-1594. St. Joseph, Michigan: American Society of Agricultural Engineers. 18 p.
- Holtorf, Russel. 1982. Elliptical Load Path Formula Derivation; unpublished notes; Umatilla National Forest. 2 p.

- Inglis, Sir Charles. 1951. *Applied Mechanics for Engineers*; Cambridge at the University Press. 404 p.
- Iwafuji Industrial Company, Ltd. 1987. Advertising brochure and personal communications with Mr. Minoru Magaoka.
- Larsen, William E., Michael J. Gonsior and W. Robert Taylor. 1985. *Cable Forwarding System Proof of Concept Facility Design, Attachment 3, Flow Chart and Computer Program for Analysis of Multispan Multi-Load Cable System Between Two Control Sheaves*; USDA Forest Service Inter-Mountain Research Station, unpublished internal report. 23 p.
- Lysons, Hilton H. and Charles N. Mann. 1967. *Skyline Tension and Deflection Handbook*; USDA Forest Service, Pacific Northwest Forest and Range Experiment Station, Research Paper PNW-39. 41 p.
- Mills, Russell. 1932. *Tension in Logging Skylines*. Bulletin 66. Univ. of Wash. Engr. Exp. Sta., Seattle. 30 p.
- Nickerson, Devon B. 1980. *Skyline Payload Analysis Using a Desktop Computer*; USDA Forest Service, Portland, Oregon. 137 p.
- Peyrot, Alain H., Robert O. Kluge and Jun W. Lee. 1978. *Longitudinal Loading Tests on a Transmission Line*; Electric Power Research Inst. 129 p.
- Sessions, John. 1986. *Class Notes for FE 564, Cable Mechanics I*; unpublished course material; Oregon State University Department of Forest Engineering. 183 p.

Slepko, I. I. and A. A. Pustovoitov. 1974. Method of Calculating the Skyline for a Multispan Cableway With Any Given Number of Loads; Lesnoi Zhurnal. pp. 40-47.

Studier, Donald D. and Virgil W. Binkley. 1974. Cable Logging Systems; USDA Forest Service, Pacific Northwest Region. 209 p.

APPENDICES

7. TERMINOLOGY (APPENDIX A)

The following terms are defined as used in this thesis:

S	length of a cable segment, ft
SELLIPT	radius of ellipse used in elliptical load path formula, ft
TUP	tension at upper end of segment, lb
TLO	tension at lower end of segment, lb
FH	horizontal component of segment tension, lb
VUP	vertical component of segment tension at upper end, lb
VLO	vertical component of segment tension at lower end, lb
THETAUP	angle from segment to horizontal at upper end, radians
THETALO	angle from segment to horizontal at lower end, radians
T _n LT	tension at left end of segment <i>n</i> , lb
T _n RT	tension at right end of segment <i>n</i> , lb
T1MAX	skyline tension at headspar, lb
FH _{<i>n</i>}	horizontal component of tension of segment <i>n</i> , lb
V _n LT	vertical component of tension at left end of segment <i>n</i> , lb
V _n RT	vertical component of tension at right end of segment <i>n</i> , lb
S _{<i>n</i>} 0	unstretched length of segment <i>n</i> , ft
S _{<i>n</i>}	stretched length of segment <i>n</i> , ft
HY	vertical projection of segment length, ft
D	horizontal projection of segment length, ft
M	catenary parameter, ft
ω	segment unit weight, lb/ft
STRETCH	elongation of segment due to tension, ft
XUP	horizontal distance from catenary origin to upper end of segment, ft
XLO	horizontal distance from catenary origin to lower end of segment, ft
EMOD	segment elastic modulus, psi
ERRLIM	tolerance level used in iterative search
DELTA	difference of dependent variable from last iteration
SOCRIT	required unstretched skyline length, ft
SCRIT	required stretched skyline length, ft
SOTOTAL	total unstretched skyline length, ft
Y(TP)	carriage height, ft
C	Intermediate result
YLT	elevation of the left support, ft
Y	In elliptical load path computation, the difference in elevation between the left and right supports, ft
P	net payload, lb
P0	required net payload for load path, lb
f ₁₁	partial derivative of payload with respect to carriage height, lb/ft
f ₂₁	partial derivative of unstretched skyline length with respect to carriage height, ft/ft
f ₁₂	partial derivative of payload with respect to upper end skyline tension, lb/lb

f_z	partial derivative of unstretched skyline length with respect to upper end skyline tension, ft/lb
δY	change or perturbation in carriage elevation,
δT_{MAX}	change or perturbation in T_{MAX} .
THETAJ	angle of the skyline to the horizontal for the skyline segment directly below the jack, degrees
ALPHA	angle of the mainline to the horizontal at the carriage, degrees
CARWT	carriage weight, lb
SQWT	weight of squirrel carriage, lb
SQX	horizontal distance from headspar to squirrel carriage, ft
SQY	elevation of squirrel carriage, ft
RX	horizontal component of unbalanced force against squirrel carriage, lb, positive right
RY	vertical component of unbalanced force against squirrel carriage, lb, positive upward
FHJACK	horizontal component of force applied on squirrel carriage by jack when squirrel carriage rests against jack, lb
FHTOWER	horizontal component of force applied on squirrel carriage by headspar when squirrel carriage rests against headspar, lb
FRIGHTIS	resultant force acting rightward on intermediate support, lb
FDOWNIS	resultant force acting downward on intermediate support, lb
YMAX	maximum feasible carriage elevation, ft
YMIN	minimum feasible carriage elevation, ft

8. SAMPLE OUTPUT (APPENDIX B)

 PROFILE DATA

TOTAL HORIZONTAL SPAN DISTANCE= 800 ,FT
 FRACTION OF TOTAL H.S.D. IN UPPER SPAN= .5
 GROUND SLOPE IN UPPER SPAN=-40 PERCENT
 CHORDSLOPE BREAK= 5 DEGREES
 TPMAX= 12

	GROUND ELEVATION	
TP#	X COORDINATE	Y COORDINATE
1	0.00	1000.00
2	80.00	968.00
3	160.00	936.00
4	240.00	904.00
5	320.00	872.00
6	400.00	840.00
7	410.00	834.95
8	480.00	799.59
9	560.00	759.17
10	640.00	718.76
11	720.00	678.35
12	800.00	637.93

 YARDER DATA

YARDER NAME: MADILL 071
 HEADSPAR HEIGHT 49
 CARRIAGE WEIGHT 1500
 CARRIAGE DEPTH 0 ,FT
 SQUIRREL CARRIAGE WEIGHT 200 ,LB

LINE	DIAMETER (IN)	WEIGHT (LB/FT)	SWL (LB)	LENGTH (FT)	ELAST MOD (PSI)	AREA (SQ IN)
SKYLINE	1.000	1.85	34500	1930	120E+05	0.4650
MAINLINE	0.625	0.72	13700	1885	120E+05	0.1816
HAULBACK	0.500	0.46	8900	4200	120E+05	0.1163
SLACKPULLING	0.000	0.00	0	0	120E+05	0.0000

SETTING DATA

NUMBER OF INTERMEDIATE SUPPORTS: 1
 MINIMUM CARRIAGE CLEARANCE: 15
 INNER YARDING LIMIT: 2
 OUTER YARDING LIMIT: 11

	TERRAIN POINT	HEIGHT TO SKYLINE (FT)
HEADSPAR	1	49
INTERMEDIATE SUPPORT # 1	6	40
TAILSPAR	12	40

LOGS ASSUMED TO BE FULLY SUSPENDED--

MULTISPAN OUTPUT, NORMAL MULTISPAN SYSTEM, 06-08-1988 01:57:38

	SQWT	TSHD	USP	PERCENTU	BREAK						
	200.00	800.00	0.50	-40.00	5.00						
	MAX TENSION	CAR	NET	UNSTRETCH	MAINL	FORCE	ON JACK	SQ	CAR	COORD	
TP	SKYL	MAINL	CLRNC	PAYLOAD	SKYL LGTH	CLRNC	DOWN	RIGHT	X	Y	
2	34500	4439	27.25	8118	879.24	49.00	4439	-1918	0.00	0.00	
3	34500	3162	21.58	6117	879.24	34.31	5441	-2252	0.00	0.00	
4	34500	2850	20.19	6043	879.24	27.71	6785	-2647	0.00	0.00	
5	34500	2996	23.09	7797	879.24	26.68	9483	-3263	0.00	0.00	
TERRAIN POINT 6 :AT SUPPORT. SUPPORT X = 400											
7	34500	12444	30.48	16434	879.24	29.76	15232	-12301	0.00	0.00	
8	34500	4529	18.98	6947	879.24	13.79	7917	-4565	0.00	0.00	
9	34500	3485	15.00	5537	879.24	4.27	6019	-3201	0.00	0.00	
10	34500	3285	15.51	5652	879.24	-1.25	4969	-2528	0.00	0.00	
11	34500	3617	20.50	7523	879.24	-1.89	4135	-2030	0.00	0.00	

MULTISPAN OUTPUT, COMPOUND JACK SYSTEM, 06-08-1988 01:57:43

	SQWT	TSHD	USP	PERCENTU	BREAK						
	200.00	800.00	0.50	-40.00	5.00						
	MAX TENSION	CAR	NET	UNSTRETCH	MAINL	FORCE	ON JACK	SQ	CAR	COORD	
TP	SKYL	MAINL	CLRNC	PAYLOAD	SKYL LGTH	CLRNC	DOWN	RIGHT	X	Y	
2	34500	4439	27.25	8118	879.24	49.00	4439	-1918	0.00	0.00	
3	34500	3162	21.58	6117	879.24	34.31	5441	-2252	0.00	0.00	
4	34500	2850	20.19	6043	879.24	27.71	6785	-2647	0.00	0.00	
5	34500	2996	23.09	7797	879.24	26.68	9483	-3263	0.00	0.00	
TERRAIN POINT 6 :AT SUPPORT. SUPPORT X = 400											
7	30372	13700	32.26	19411	879.24	40.00	17881	-13533	0.00	0.00	
8	34500	5193	18.98	8255	879.24	37.29	9188	-5286	0.00	0.00	
9	34500	3798	15.00	6209	879.24	26.59	6797	-3607	0.00	0.00	
10	34500	3495	15.51	6132	879.24	21.78	5614	-2851	0.00	0.00	
11	34500	3785	20.50	7926	879.24	22.84	4747	-2329	0.00	0.00	

MULTISPAN OUTPUT, SQUIRREL CARRIAGE SYSTEM, 06-08-1988 01:57:51

	SQWT	TSHD	USP	PERCENTU	BREAK						
	200.00	800.00	0.50	-40.00	5.00						
	MAX TENSION	CAR	NET	UNSTRETCH	MAINL	FORCE	ON JACK	SQ	CAR	COORD	
TP	SKYL	MAINL	CLRNC	PAYLOAD	SKYL LGTH	CLRNC	DOWN	RIGHT	X	Y	
2	34500	4439	27.25	7918	879.24	49.00	4439	-1918	80.00	995.25	
3	34500	3162	21.58	5917	879.24	34.31	5441	-2252	160.00	957.58	
4	34500	2850	20.19	5843	879.24	27.71	6785	-2647	240.00	924.19	
5	34500	2996	23.09	7597	879.24	26.68	9483	-3263	320.00	895.09	
TERRAIN POINT 6 :AT SUPPORT. SUPPORT X = 400											
7	34500	12724	30.64	17288	879.24	30.85	16191	-12568	341.21	901.94	
8	34500	4788	19.16	7531	879.24	26.14	8706	-4861	346.51	900.40	
9	34500	3731	15.08	6081	879.24	23.93	6861	-3531	380.17	887.52	
10	34500	3494	15.51	6130	879.24	21.73	5812	-2850	399.50	880.19	
11	34500	3784	20.50	7924	879.24	22.82	4945	-2328	399.50	880.19	

LOADPATH COMPUTATION

UNSTRETCHED SKYLINE LENGTH= 879.24, NET PAYLOAD= 5537.41

MULTISPAN OUTPUT, NORMAL MULTISPAN SYSTEM, 06-08-1988 01:59:02

	SQWT	TSHD	USP	PERCENTU	BREAK	FORCE ON JACK		SQ	CAR	COORD	
	200.00	800.00	0.50	-40.00	5.00	DOWN	RIGHT				
TP	SKYL	MAINL	CLRNC	NET	UNSTRETCH	MAINL	CLRNC	DOWN	RIGHT	X	Y
2	30530	3192	30.38	5537	879.24	49.00	3749	-1639	0.00	0.00	
3	33402	2921	22.53	5537	879.24	34.71	5170	-2151	0.00	0.00	
4	33534	2669	21.00	5537	879.24	28.11	6457	-2537	0.00	0.00	
5	30893	2365	25.59	5538	879.24	27.79	7622	-2756	0.00	0.00	
TERRAIN POINT 6 :AT SUPPORT. SUPPORT X = 400											
7	24141	4315	35.58	5538	879.24	34.48	7462	-4798	0.00	0.00	
8	32009	3771	20.99	5537	879.24	14.83	6964	-3938	0.00	0.00	
9	34499	3485	15.00	5537	879.24	4.27	6019	-3201	0.00	0.00	
10	34276	3238	15.70	5537	879.24	-1.33	4923	-2503	0.00	0.00	
11	31321	2943	22.77	5538	879.24	-4.52	3662	-1785	0.00	0.00	

LOADPATH COMPUTATION

UNSTRETCHED SKYLINE LENGTH= 879.24, NET PAYLOAD= 5537.41

MULTISPAN OUTPUT, COMPOUND JACK SYSTEM, 06-08-1988 01:59:11

	SQWT	TSHD	USP	PERCENTU	BREAK	FORCE ON JACK		SQ	CAR	COORD	
	200.00	800.00	0.50	-40.00	5.00	DOWN	RIGHT				
TP	SKYL	MAINL	CLRNC	NET	UNSTRETCH	MAINL	CLRNC	DOWN	RIGHT	X	Y
2	30530	3192	30.38	5537	879.24	49.00	3749	-1639	0.00	0.00	
3	33402	2921	22.53	5537	879.24	-34.71	5170	-2151	0.00	0.00	
4	33534	2669	21.00	5537	879.24	28.11	6457	-2537	0.00	0.00	
5	30893	2365	25.59	5537	879.24	27.79	7622	-2756	0.00	0.00	
TERRAIN POINT 6 :AT SUPPORT. SUPPORT X = 400											
7	22998	4099	36.39	5537	879.24	39.12	7563	-4609	0.00	0.00	
8	30410	3729	22.39	5537	879.24	37.69	7228	-4018	0.00	0.00	
9	33255	3479	16.14	5537	879.24	27.08	6394	-3371	0.00	0.00	
10	33387	3245	16.48	5537	879.24	22.28	5346	-2704	0.00	0.00	
11	30773	2960	23.19	5537	879.24	24.14	4092	-1990	0.00	0.00	

LOADPATH, UNSTRETCHED SKYLINE LENGTH= 879.24, NET PAYLOAD= 5537.41

MULTISPAN OUTPUT, SQUIRREL CARRIAGE SYSTEM, 06-08-1988 01:59:22

	SQWT	TSHD	USP	PERCENTU	BREAK	FORCE ON JACK		SQ	CAR	COORD	
	200.00	800.00	0.50	-40.00	5.00	DOWN	RIGHT				
TP	SKYL	MAINL	CLRNC	NET	UNSTRETCH	MAINL	CLRNC	DOWN	RIGHT	X	Y
2	30845	3288	30.11	5537	879.24	49.00	3803	-1661	80.00	998.11	
3	33783	3004	22.20	5537	879.24	34.57	5264	-2186	160.00	958.20	
4	33917	2741	20.68	5537	879.24	27.95	6587	-2580	240.00	924.68	
5	31219	2422	25.35	5537	879.24	27.70	7787	-2803	320.00	897.35	
TERRAIN POINT 6 :AT SUPPORT. SUPPORT X = 400											

7	23595	4134	36.02	5537	879.24	37.13	7741	-4637	388.90	883.99
8	30943	3722	22.05	5537	879.24	30.98	7356	-3978	372.07	890.50
9	33378	3476	16.07	5537	879.24	25.57	6563	-3354	389.53	883.96
10	33391	3245	16.48	5538	879.24	22.23	5545	-2703	399.50	880.19
11	30775	2960	23.19	5537	879.24	24.11	4291	-1989	399.50	880.19

9. PROGRAM LISTINGS (APPENDIX C)

```

*****
' * MULTI: a model for analysis of multispans skyline logging. MULTI *
' * analyzes a conventional multispans system, a system supporting the *
' * mainline as well as the skyline at the intermediate support *
' * (compound jack), and a squirrel carriage system. The setting is *
' * assumed to have two spans with the yarder in the upper span and *
' * gravity outhaul. The yarder and cable specifications must be *
' * stored in a file in the default directory named "multi.yrd", in the *
' * format shown in subroutine 5000. The profile is assumed to consist *
' * of two straight segments with the intermediate support at the break *
' * between segments. Results are output to either the screen, the *
' * printer or a file named "out.dat". In addition, more detailed *
' * output is printed to the file "results.dat". Two programs are needed *
' * to run MULTI, SQ.BAS and UTIL.BAS. The program is written for *
' * TURBO BASIC. An executable file of this program, MULTI.EXE, is *
' * included on this disk for users who do not have TURBO BASIC. For *
' * further information contact Tom Durston, Stanislaus National Forest, *
' * (209) 532-3671 *
*****

```

```

'SQ.BAS
'REV 6/9/88

```

```

'*** VARIABLE TYPE DEFINITIONS ***

```

```

DEFDBL A-Z
DEFINT I

```

```

'*** INITIAL VALUES ***

```

```

%SL=1           'SKYLINE IDENTIFIER
%ML=2           'MAINLINE IDENTIFIER
%HB=3           'HAULBACK IDENTIFIER
%SP=4           'SLACKPULLING LINE IDENTIFIER
%TRUE=1        'NUMERIC VALUE OF %TRUE
%FALSE=0       'NUMERIC VALUE OF %FALSE
%TERSE=2       'NUMERIC VALUE FOR TERSE DEBUG MESSAGES
PI=4*ATN(1)    'RATIO OF CIRCUMFERENCE TO DIAMETER OF CIRCLE

```

```

'*** TOLERANCES FOR NUMERIC SEARCHES ***

```

```

PERRLIM=.49
SOERRLIM=.001
FERRLIM=.49

```

```

'*** OUTPUT FORMAT STRINGS ***

```

```

C4$="\ \ "
I4$="####"
E8$="#####^ ^ ^ ^ "
C8$="\ \ "
R8$="#####.## "
I8$="##### "
E10$="#####^ ^ ^ ^ "
C10$="\ \ "
R10$="#####.## "
I10$="##### "

```

```

P10$="#####.#### "
C15$="\
R15$="#####.## "
P15$="#####.#### "
CLOSE
DEVICE$="1"
OPEN "SCRN:" FOR OUTPUT AS #2
$SEGMENT

100'*** PROFILE SPECIFICATIONS ***
ON ERROR GOTO ERRORHANDLER
DEBUG=%FALSE
GOSUB 3000'CHOOSE OUTPUT DEVICE
GOSUB 5000'LOAD YARDER
INPUT "WEIGHT OF SQUIRREL CARRIAGE (lb)";SQWT
INPUT "TOTAL SPAN HORIZONTAL DISTANCE (ft)";TSHD
INPUT "RATIO OF UPPER SPAN HOR. DIST. TO TOTAL SPAN HOR. DIST.";USP
INPUT "UPPER SPAN SLOPE (% , must be negative!);PERCENTU
INPUT "BREAK IN SLOPE (degrees)";BREAK
OPEN "RESULTS.DAT" FOR OUTPUT AS #3
GOSUB 200
CLOSE#3
PRINT#2, TIMES$
CLOSE
SOUND 200,2

END

200' LOGGING SYSTEM LEVEL CONTROLLER
GOSUB 1000'GENERATE PROFILE
PRINT#2, TIMES$
GOSUB 2300'OUTPUT FILE HEADER
T1MAX=SWL(%SL)
GOSUB 10000' SCRIT
GOSUB 11000'MINT1MAX
%TOOHIGH=3 'TEST VALUE USED IN 31100
DS=-.01
DT=-50
P0=10E10 'INITIALIZE LOADPATH NET LOAD
SYS=1:MSTYPE$="NORMAL MULTISPAN"
GOSUB 20000
SYS=2:MSTYPE$="COMPOUND JACK"
T1MAX=SWL(%SL)
GOSUB 20000
SYS=3:MSTYPE$="SQUIRREL CARRIAGE"
T1MAX=SWL(%SL)
GOSUB 30000
SYS=1:MSTYPE$="NORMAL MULTISPAN"
T1MAX=SWL(%SL)
GOSUB 22000
SYS=2:MSTYPE$="COMPOUND JACK"
T1MAX=SWL(%SL)
GOSUB 22000
SYS=3:MSTYPE$="SQUIRREL CARRIAGE"
T1MAX=SWL(%SL)

```

```

GOSUB 33000
999' RESUME AFTER ERROR
RETURN

```

ERRORHANDLER:

```

WRITE#3,"ERROR OCCURRED @ TP ";TP;"SQWT ";SQWT;"TSHD";TSHD;"USP ";USP;_
"PERCENTU ";PERCENTU;"BREAK ";BREAK;"MSTYPES";MSTYPES
CLOSE#3
OPEN "ERFILE" FOR OUTPUT AS #3
BEEP:BEEP
RESUME 999

```

```

$INCLUDE "UTIL.BAS"

```

```

10000'SCRIT
'SUBROUTINE CALCULATES CRITICAL SKYLINE LENGTH BASED ON SPECIFIED
'CARRIAGE CLEARANCE
GOSUB 10100'HI SUPPORT
FOR TP=1 TO OYL
  GOSUB 10200'SUPPORT TENSIONS
NEXT TP
FOR SPAN=1 TO NUMIS+1
  TP=SUPTP (SPAN)+1
  GOSUB 10300'S UNLOADED
  FOR TP=SUPTP (SPAN)+1 TO SUPTP (SPAN+1)-1
    SOULTP (SPAN, TP)=SOUNLOADED (SPAN)
    SULTP (SPAN, TP)=SUNLOADED (SPAN)
  NEXT TP
  SOLOADED (SPAN)=100000:SLOADED (SPAN)=100000
NEXT SPAN
FOR TP=IYL TO OYL
  SPAN=FNSPAN (TP)
  IF ATSUPPORT=%FALSE THEN
    TILT=RTSUPT (LTSUP)
    GOSUB 10400'S LOADED
  END IF
NEXT TP
GOSUB 10500'MIN S TOTAL
RETURN

```

```

10100'HI SUPPORT
HISUPPORT=1
Y (HISUPPORT)=SUPY (1)
FOR SUPPORT=2 TO NUMIS+2
  IF SUPY (SUPPORT)>SUPY (HISUPPORT) THEN
    HISUPPORT=SUPPORT
    SUPY (HISUPPORT)=SUPY (SUPPORT)
  END IF
NEXT SUPPORT
RETURN

```

```

10200'SUPPORT TENSIONS (T1MAX,HISUPPORT) FOR ALL TP
FOR SUPPORT=1 TO NUMIS+2

```

```

        LTSUPT (SUPPORT) = T1MAX - OMEGA (%SL) * (SUPY (HISUPPORT) - SUPY (SUPPORT))
        RTSUPT (SUPPORT) = LTSUPT (SUPPORT)
    NEXT SUPPORT
RETURN

```

```

10300'S UNLOADED (SPAN, LTSUPT (RTSUP), RTSUPT (LTSUP))
    LTSUP = SPAN
    RTSUP = SPAN + 1
    OMEGA = OMEGA (%SL)
    EMOD& = EMOD& (%SL)
    A = A (%SL)
    D = SUPX (RTSUP) - SUPX (LTSUP)
    HY = ABS (SUPY (LTSUP) - SUPY (RTSUP))
    TUP = RTSUPT (LTSUP)
    IF LTSUPT (RTSUP) > TUP THEN TUP = LTSUPT (RTSUP)
    TLO = TUP - OMEGA * HY
    CALL M (D, HY, OMEGA, TUP, DEBUG)
    CALL CATFORCES (HY, M, D, OMEGA, DEBUG)
    IF SUPY (LTSUP) > SUPY (RTSUP) THEN
        'UPPER END LEFT
        VULT = VUP
        VURT = VLO
    ELSE
        'UPPER END RIGHT
        VULT = VLO
        VURT = VUP
    END IF
    FHU = FH
    CALL UNSTRETCH (M, TUP, TLO, A, EMOD&, S, OMEGA, DEBUG)
    SOUNLOADED (SPAN) = S0
    SUNLOADED (SPAN) = S
RETURN

```

```

10400'S LOADED
    Y (TP) = ELEV (TP) + CC
    IF Y (TP) > CHORD (TP) THEN
        PRINT#2, "CC RAISES CARRIAGE ABOVE CHORD"
        PRINT#2, USING C8$; "TP"; "ELEV (TP) "; "CC"; "Y (TP) "; "CHORD (TP) "
        PRINT#2, USING R8$; TP; ELEV (TP); CC; Y (TP); CHORD (TP)
    END IF
    GOSUB 21100' POINT PAYLOAD
    IF S10 + S20 < S0LOADED (SPAN) THEN S0LOADED (SPAN) = S10 + S20
    IF S1 + S2 < SLOADED (SPAN) THEN SLOADED (SPAN) = S1 + S2
RETURN

```

```

10500'MIN S TOTAL
    SOCRIT = 100000
    SCRIT = 100000
    FOR LOADEDSPAN = 1 TO NUMIS + 1
        S0 = S0LOADED (LOADEDSPAN)
        S = SLOADED (LOADEDSPAN)
        FOR SPAN = 1 TO NUMIS + 1
            IF SPAN <> LOADEDSPAN THEN
                S0 = S0 + SOUNLOADED (SPAN)
            END IF
        END FOR
    END FOR

```



```

        S=S+SUNLOADED (SPAN)
      END IF
    NEXT SPAN
    IF S0<S0CRIT THEN S0CRIT=S0
    IF S<SCRIT THEN SCRIT=S
  NEXT LOADEDSPAN
RETURN

```

```

11000'MINT1MAX
  T1MAX=SWL(%SL)*.9
  GOSUB 10200'SUPPORT TENSIONS
  S0TOTAL=0
  FOR SPAN=1 TO NUMIS+1
    GOSUB 10300'S UNLOADED
    S0TOTAL=S0TOTAL+S0UNLOADED (SPAN)
  NEXT SPAN
  T1MAXOLD=T1MAX:T1DELTASOLD=S0CRIT-S0TOTAL
  T1MAX=SWL(%SL)*.8
  GOSUB 10200'SUPPORT TENSIONS
  S0TOTAL=0
  FOR SPAN=1 TO NUMIS+1
    GOSUB 10300'S UNLOADED
    S0TOTAL=S0TOTAL+S0UNLOADED (SPAN)
  NEXT SPAN
  T1MAXREC=T1MAX:T1DELTASREC=S0CRIT-S0TOTAL
  WHILE ABS(T1DELTASREC)>S0ERRLIM/1000
    T1MAX=FNSECANT(T1MAXOLD,T1MAXREC,T1DELTASOLD,T1DELTASREC)
    GOSUB 10200'SUPPORT TENSIONS
    S0TOTAL=0
    FOR SPAN=1 TO NUMIS+1
      GOSUB 10300'S UNLOADED
      S0TOTAL=S0TOTAL+S0UNLOADED (SPAN)
    NEXT SPAN
    T1MAXOLD=T1MAXREC:T1DELTASOLD=T1DELTASREC
    T1MAXREC=T1MAX:T1DELTASREC=S0CRIT-S0TOTAL
  WEND
  MINT1MAX=T1MAX
RETURN

```

```

20000'MAX TENSION PAYLOAD (TP, SELLIPT, T1LT)
  GOSUB 20100'ELLIPTICAL LOAD PATH
  GOSUB 2000'MULTISPAN HEADER
  FOR TP=IYL TO OYL
    SPAN=FNSPAN (TP)
    IF ATSUPPORT=%TRUE THEN
      PRINT#2,"TERRAIN POINT ";TP;":AT SUPPORT.  SUPPORT X = ";SUPX(2)
    ELSE
      T1MAX=SWL(%SL)
      GOSUB 10200'SUPPORT TENSIONS
      Y (TP)=SUPY (LTSUP)-ELLIPTH (TP)
      GOSUB 21100'POINT PAYLOAD
      IF ABS(S0CRIT-S0TOTAL)>S0ERRLIM THEN GOSUB 20200'CORRECT S0
    END IF
  NEXT TP

```

```

IF TP<SUPTP(2) THEN THETAJ=0
IF MLT>SWL(%ML) THEN GOSUB 20300'CORRECT MLT
CLRTP0=HS'      TP OF MINIMUM MAINLINE CLEARANCE
MINMLHT=HSHT'   LOWEST MAINLINE CLEARANCE ABOVE GROUND
IF SYS=1 OR SYS=3 OR FNSPAN(TP)=1 THEN
  M=M3
  MLTTHETALO=THETALO3
  FOR CLRTP=HS+1 TO TP-1
    D=X(TP)-X(CLRTP)
    CALL MLHY(D,M,MLTTHETALO,TP,CLRTP)
    MLHT=Y(TP)+MLHY-ELEV(CLRTP)
    IF MINMLHT>MLHT THEN
      MINMLHT=MLHT
      CLRTP0=CLRTP
    END IF
  NEXT CLRTP
ELSE' SYS=2, SECOND SPAN
' LOWER SPAN
  M=M4
  MLTTHETALO=THETALO4
  FOR CLRTP=SUPTP(LTSUP) TO TP-1
    D=X(TP)-X(CLRTP)
    CALL MLHY(D,M,MLTTHETALO,TP,CLRTP)
    MLHT=Y(TP)+MLHY-ELEV(CLRTP)
    IF MINMLHT>MLHT THEN
      MINMLHT=MLHT
      CLRTP0=CLRTP
    END IF
  NEXT CLRTP
' UPPER SPAN
  M=M3
  MLTTHETALO=THETALO3
  FOR CLRTP=HS+1 TO SUPTP(2)-1
    D=SUPX(2)-X(CLRTP)
    CALL MLHY(D,M,MLTTHETALO,TP,CLRTP)
    MLHT=SUPY(2)+MLHY-ELEV(CLRTP)
    IF MINMLHT>MLHT THEN
      MINMLHT=MLHT
      CLRTP0=CLRTP
    END IF
  NEXT CLRTP
  MLTTHETALO=THETALO4
END IF
GOSUB 2200'OUTPUT MULTISPAN RESULTS
IF P<P0 THEN P0=P 'SET NEW LOWEST PAYLOAD IN PROFILE
END IF
NEXT TP
RETURN

20100'ELLIPTICAL LOAD PATH
FOR LOADEDSPAN=1 TO NUMIS+1
  LTSUP=LOADEDSPAN
  RTSUP=LOADEDSPAN+1
  S=SCRIT

```

```

FOR SPAN=1 TO NUMIS+1
  IF SPAN<>LOADEDSPAN THEN S=S-SUNLOADED (SPAN)
NEXT SPAN
Y=ABS (SUPY (LTSUP) -SUPY (RTSUP))
L#=SUPX (RTSUP) -SUPX (LTSUP)
FOR TP=(SUPTP (LTSUP)+1) TO (SUPTP (RTSUP)-1)
  SELLIPT (TP)=S
  D=X (TP) -SUPX (LTSUP)
  C=(S*S) + (D*D) - (L#-D) ^2-Y*Y
  IF SUPY (LTSUP) >SUPY (RTSUP) THEN
    ELLIPTH (TP) = (C*Y+SQR (-4*D*D*S*S*(S*S-Y*Y)+C*C*S*S)) / (2*(S*S-Y*Y))
  ELSE
    ELLIPTH (TP) = (C*Y-SQR (-4*D*D*S*S*(S*S-Y*Y)+C*C*S*S)) / (2*(S*S-Y*Y))
  END IF
NEXT TP
NEXT LOADEDSPAN
RETURN

20200' CORRECT S0
XOLD=Y (TP)
DOLD=S0CRIT-S0TOTAL
NEWELLIPTH=50*((S0CRIT-S0TOTAL)/S0CRIT)*ELLIPTH (TP) +ELLIPTH (TP)
Y (TP) =SUPY (LTSUP) -NEWELLIPTH
IF Y (TP) >CHORD (TP) THEN Y (TP) =CHORD (TP)
XREC=Y (TP)
GOSUB 21100
DREC=S0CRIT-S0TOTAL
DO WHILE ABS (S0CRIT-S0TOTAL) >S0ERRLIM
  Y (TP) =FNSECANT (XOLD, XREC, DOLD, DREC)
  IF Y (TP) >CHORD (TP) THEN
    Y (TP) =CHORD (TP)
    PRINT#2, "REDUCED Y (TP) TO CHORD IN 5241: ";CHORD (TP)
  END IF
  XOLD=XREC
  XREC=Y (TP)
  GOSUB 21100' POINT PAYLOAD
  DOLD=DREC
  DREC=S0CRIT-S0TOTAL
  IF XREC=CHORD (TP) AND XOLD=CHORD (TP) THEN
    PRINT#2, "NO FEASIBLE SOLUTION. CARRIAGE AT CHORD HEIGHT."
    EXIT LOOP
  END IF
LOOP
RETURN

20300' CORRECT MLT
T1MAXOLD=T1MAX
DELTAMLTREC=SWL (%ML) -MLT
T1MAX=(DELTAMLTREC/SWL (%ML))*T1MAXOLD+T1MAX
IF T1MAX<MINT1MAX+300 THEN T1MAX=MINT1MAX+300
T1MAXREC=T1MAX
GOSUB 10200' SUPPORT TENSIONS
SPAN=FNSPAN (TP)

```

```

Y(TP)=SUPY(LTSUP)-ELLIPTH(TP)
GOSUB 21100' POINT PAYLOAD
GOSUB 20200' CORRECT S0
DELTAMLTREC=SWL(%ML)-MLT
WHILE ABS(SWL(%ML)-MLT)>FERRLIM
  TIMAX=FNSECANT(TIMAXOLD,TIMAXREC,DELTAMLTOLD,DELTAMLTREC)
  IF TIMAX<MINTIMAX+300 THEN TIMAX=MINTIMAX+300
  TIMAXOLD=TIMAXREC
  TIMAXREC=TIMAX
  GOSUB 10200' SUPPORT TENSIONS
  TILT=RTSUPT(LTSUP)
  SPAN=FNSPAN(TP)
  Y(TP)=SUPY(LTSUP)-ELLIPTH(TP)
  GOSUB 21100' POINT PAYLOAD
  IF ABS(SOCRIT-S0TOTAL)>S0ERRLIM THEN GOSUB 20200' CORRECT S0
  DELTAMLTOLD=DELTAMLTREC
  DELTAMLTREC=SWL(%ML)-MLT
WEND
RETURN

5260' CORRECT HBT
RETURN

21000' CONVENTIONAL PAYLOAD AT A POINT GIVEN SELLIPT
SELLIPT(TP)=SELLIPT
SPAN=FNSPAN(TP)
Y(TP)=FNELLIPT(YLT,YRT,SELLIPT,HSD,D,DEBUG)
GOSUB 21100' POINT PAYLOAD(TP,TILT,Y(TP))
RETURN

21100' CONVENTIONAL PAYLOAD AT A POINT GIVEN Y(TP)
'*** NORMAL MULTISPAN OR MAINLINE SUSPENDED AT JACK ***
'*** GIVEN TP,TILT, Y(TP), LTSUP, RTSUP ***
GOSUB 10200' SUPPORT TENSIONS
TILT=RTSUPT(LTSUP)
LOADEDSPAN=FNSPAN(TP)
FOR SPAN=1 TO NUMIS+1
  IF SPAN<>LOADEDSPAN THEN GOSUB 10300'S UNLOADED
NEXT SPAN
SPAN=FNSPAN(TP)
OMEGA=OMEGA(%SL)
A=A(%SL)
EMOD&=EMOD&(%SL)
D=X(TP)-SUPX(LTSUP)
HY=SUPY(LTSUP)-Y(TP)
IF HY<0 THEN
  UPPEREND$="RIGHT"
  HY=-HY
  TUP=TILT+OMEGA*HY
  CALL M(D,HY,OMEGA,TUP,DEBUG)
  CALL CATFORCES(HY,M,D,OMEGA,DEBUG)
  TIRT=TUP
  VILT=-VLO

```

```

V1RT=-VUP
THETA1RT=THETAUP
ELSE
UPPEREND$="LEFT"
TUP=T1LT
CALL M (D, HY, OMEGA, TUP, DEBUG)
CALL CATFORCES (HY, M, D, OMEGA, DEBUG)
T1RT=TLO
V1LT=VUP
V1RT=VLO
THETA1RT=THETALO
END IF
FH1=FH
S1=S
CALL UNSTRETCH (M, TUP, TLO, A, EMOD&, S, OMEGA, DEBUG)
S10=S0
THETAJ=PI-THETA1RT
T2LT=T1RT
D=SUPX (RTSUP) -X (TP)
HY=Y (TP) -SUPY (RTSUP)
IF HY<0 THEN
UPPEREND$="RIGHT"
HY=-HY
TUP=T2LT+OMEGA*HY
CALL M (D, HY, OMEGA, TUP, DEBUG)
CALL CATFORCES (HY, M, D, OMEGA, DEBUG)
V2LT=-VLO
V2RT=-VUP
T2RT=TUP
THETA2LT=THETALO
ELSE
UPPEREND$="LEFT"
TUP=T2LT
CALL M (D, HY, OMEGA, TUP, DEBUG)
CALL CATFORCES (HY, M, D, OMEGA, DEBUG)
V2LT=VUP
V2RT=VLO
T2RT=TLO
THETA2LT=THETAUP
END IF
FH2=FH
S2=S
CALL UNSTRETCH (M, TUP, TLO, A, EMOD&, S, OMEGA, DEBUG)
S20=S0
A=A (%ML)
OMEGA=OMEGA (%ML)
EMOD&=EMOD& (%ML)
IF SYS=1 OR SYS=3 OR FNSPAN (TP)=1 THEN
FH3=FH2-FH1
FH=FH3
M3=FH/OMEGA
D=X (TP) -SUPX (HS)
HY=SUPY (HS) -Y (TP)
IF HY<0 THEN

```

```

UPPEREND$="RIGHT"
HY=-HY
CALL CATFORCES (HY, M3, D, OMEGA, DEBUG)
V3LT=-VLO
V3RT=-VUP
T3LT=TLO
T3RT=TUP
ELSE
UPPEREND$="LEFT"
CALL CATFORCES (HY, M3, D, OMEGA, DEBUG)
V3LT=VUP
V3RT=VLO
T3LT=TUP
T3RT=TLO
END IF
THETALO3=THETALO
IF T3LT>T3RT THEN MLT=T3LT ELSE MLT=T3RT
S3=S
IF FNSPAN(TP)=1 THEN
FDOWNHS=V1LT+V3LT
FRIGHTHS=FH1+FH3
FDOWNIS=VULT-V2RT
FRIGHTIS=FHU-FH2
FDOWNTS=-VURT
FRIGHTTS=-FHU
ELSE
FDOWNHS=VULT+V3LT
FRIGHTHS=FHU+FH3
FDOWNIS=V1LT-VURT
FRIGHTIS=FH1-FHU
FDOWNTS=-V2RT
FRIGHTTS=-FH2
END IF
IF SYS=3 AND SPAN=1 THEN EFFCRWT=CRWT+SQWT ELSE EFFCRWT=CRWT
P=V1RT+V3RT-V2LT-EFFCRWT

ELSE' SYS=2, SUSPENDED MAINLINE
' SEGMENT 4, CARRIAGE TO INTERMEDIATE SUPPORT
FH4=FH2-FH1
FH=FH4
M4=FH/OMEGA
D=X(TP)-SUPX(LTSUP)
HY=SUPY(LTSUP)-Y(TP)
IF HY<0 THEN
UPPEREND$="RIGHT"
HY=-HY
CALL CATFORCES (HY, M4, D, OMEGA, DEBUG)
V4LT=-VLO
V4RT=-VUP
T4LT=TLO
T4RT=TUP
ELSE
UPPEREND$="LEFT"
CALL CATFORCES (HY, M4, D, OMEGA, DEBUG)

```

```

V4LT=VUP
V4RT=VLO
T4LT=TUP
T4RT=TLO
END IF
THETALO4=THETALO
IF T4LT>T4RT THEN MLT=T4LT ELSE MLT=T4RT
S4=S

' SEGMENT 3, MAINLINE, HEADSPAR TO INTERMEDIATE SUPPORT
D=SUPX(2)-SUPX(HS)
HY=SUPY(HS)-SUPY(2)
TUP=T4LT+OMEGA*HY
CALL M(D,HY,OMEGA,TUP,DEBUG)
M3=M
IF HY<0 THEN
  UPPEREND$="RIGHT"
  HY=-HY
  CALL CATFORCES (HY,M,D,OMEGA,DEBUG)
  V3LT=-VLO
  V3RT=-VUP
  T3LT=TLO
  T3RT=TUP
ELSE
  UPPEREND$="LEFT"
  CALL CATFORCES (HY,M,D,OMEGA,DEBUG)
  V3LT=VUP
  V3RT=VLO
  T3LT=TUP
  T3RT=TLO
END IF
FH3=FH
THETALO3=THETALO
IF T3LT>T3RT AND T3LT>MLT THEN
  MLT=T3LT
ELSEIF T3RT>T3LT AND T3RT>MLT THEN
  MLT=T3RT
END IF
IF (TLO<0 OR TUP<0) THEN
  PRINT#2, "NEGATIVE MAINLINE TENSION.  NEED HAULBACK."
END IF
S3=S
P=V1RT+V4RT-V2LT-CRWT
FDOWNHS=VULT+V3LT
FRIGHTHS=FHU+FH3
FDOWNIS=V1LT-VURT+V4LT-V3RT
FRIGHTIS=FH1-FHU+FH4-FH3
FDOWNTS=-V2RT
FRIGHTTS=-FHU
END IF
SOTOTAL=S10+S20
STOTAL=S1+S2
SLT=T1MAX
FOR I=1 TO NUMIS+1

```

```

      IF I<>FNSPAN(TP) THEN
        S0TOTAL=S0TOTAL+S0UNLOADED(I)
        STOTAL=STOTAL+SUNLOADED(I)
      END IF
    NEXT I
  RETURN

22000' CONVENTIONAL LOAD PATH PROFILE LEVEL CONTROLLER
PRINT#2,
PRINT#2, SPC(23); "LOADPATH COMPUTATION"
PRINT#2, "UNSTRETCHED SKYLINE LENGTH=";
PRINT#2, USING "#####.##"; S0CRIT;
PRINT#2, ", NET PAYLOAD=";
PRINT#2, USING "#####.##"; P0
GOSUB 2000' MULTISPAN HEADER
FOR TP=HS+1 TO OYL
  DS=1
  DT=50
  SPAN=FNSPAN(TP)
  IF AT SUPPORT=%TRUE THEN
    PRINT#2, "TERRAIN POINT"; TP; ": AT SUPPORT. SUPPORT X = "; SUPX(2)
  ELSE
    T1MAX=SWL(%SL)
    Y2=S0CRIT+S0ERRLIM+1 ' INITIAL ENTRY TO LOOP
    SELLIPT=SELLIPT(TP)
    WHILE ABS(S0CRIT-Y2)>S0ERRLIM OR ABS(P0-Y1)>PERRLIM
      GOSUB 22100' GRADIENT LOADPATH
    WEND
    MINMLHT=HSHT'   LOWEST MAINLINE CLEARANCE ABOVE GROUND
    CLRTP0=HS'     TP OF MINIMUM MAINLINE CLEARANCE
    IF SYS=1 OR SYS=3 OR FNSPAN(TP)=1 THEN
      M=M3
      MLTTHETALO=THETALO3
      FOR CLRTP=HS+1 TO TP-1
        D=X(TP)-X(CLRTP)
        CALL MLHY(D,M,MLTTHETALO,TP,CLRTP)
        MLHT=Y(TP)+MLHY-ELEV(CLRTP)
        IF MINMLHT>MLHT THEN
          MINMLHT=MLHT
          CLRTP0=CLRTP
        END IF
      NEXT CLRTP
    ELSE' SYS=2, SECOND SPAN
      ' LOWER SPAN
      M=M4
      MLTTHETALO=THETALO4
      FOR CLRTP=SUPTP(LTSUP) TO TP-1
        D=X(TP)-X(CLRTP)
        CALL MLHY(D,M,MLTTHETALO,TP,CLRTP)
        MLHT=Y(TP)+MLHY-ELEV(CLRTP)
        IF MINMLHT>MLHT THEN
          MINMLHT=MLHT
          CLRTP0=CLRTP
        END IF
      NEXT CLRTP
    END IF
  END IF
NEXT TP

```



```

NEXT CLRTP
'UPPER SPAN
M=M3
MLTTHETALO=THETALO3
FOR CLRTP=HS+1 TO SUPTP(2)-1
  D=SUPX(2)-X(CLRTP)
  CALL MLHY(D,M,MLTTHETALO,TP,CLRTP)
  MLHT=SUPY(2)+MLHY-ELEV(CLRTP)
  IF MINMLHT>MLHT THEN
    MINMLHT=MLHT
    CLRTP0=CLRTP
  END IF
NEXT CLRTP
MLTTHETALO=THETALO4
END IF
GOSUB 2200'OUTPUT MULTISPAN RESULTS
IF DEVICES$="1" THEN CALL PAUSE
END IF
NEXT TP
RETURN

```

```

22100'CONVENTIONAL LOADPATH TERRAIN POINT LEVEL CONTROLLER
'*** THIS SUBROUTINE RUNS A GRADIENT SEARCH IN TWO DEPENDENT ***
'*** VARIABLES, Y1=PAYLOAD, Y2=UNSTRETCHED SKYLINE LENGTH, AND ***
'*** TWO INDEPENDENT VARIABLES, X1=ELLIPTICAL LOAD PATH PARAMETER S, ***
'*** AND X2=MAXIMUM SKYLINE TENSION AT ANY POINT ON SPAN. ***
Y10=P0
Y20=S0CRIT
'S,T
GOSUB 21000'POINT PAYLOAD(TP,T1MAX,SELLIPT)
Y1=P
Y2=S0TOTAL
IF ABS(P0-P)>PERRLIM OR ABS(S0CRIT-S0TOTAL)>S0ERRLIM THEN
  SELLIPT=SELLIPT+DS
  'S+DS,T
  GOSUB 21000'POINT PAYLOAD
  SELLIPT=SELLIPT-DS
  F11=(P-Y1)/DS
  F21=(S0TOTAL-Y2)/DS
  T1MAX=T1MAX+DT
  'S,T+DT
  GOSUB 21000'POINT PAYLOAD(TP,T1MAX,SELLIPT)
  T1MAX=T1MAX-DT
  F12=(P-Y1)/DT
  F22=(S0TOTAL-Y2)/DT
  CALL GRADIENT(F11,F12,F21,F22,Y10,Y20,Y1,Y2)
  GOSUB 22110'NEW POINT FEASIBILITY CHECK
  SELLIPT=SELLIPT+DX1
  T1MAX=T1MAX+DX2
  DS=ABS(DX1/100)
  DT=-DX2/100
  IF ABS(DS)<.01 THEN DS=.01*ABS(DS)/DS
  IF ABS(DT)<10 THEN DT=10*ABS(DT)/DT
END IF

```

RETURN

22110' CONVENTIONAL LOADPATH FEASIBILITY CHECK

'*** CHECK FOR FEASIBLE SELLIPT ***

RL=SQR((SUPY(LTSUP)-SUPY(RTSUP))^2+(SUPX(LTSUP)-SUPX(RTSUP))^2)

IF DX1<1.000001*RL-SELLIPT THEN

C=(1.000001*RL-SELLIPT)/DX1

DX1=C*DX1

'REDUCING STEP TO KEEP SELLIPT ABOVE 1.000001 RL

END IF

'*** CHECK FOR NEGATIVE T1LT ***

IF T1LT+DX2<100 THEN

C=(100-T1LT)/DX2

DX2=DX2*C

'REDUCING DX2 TO KEEP T1LT POSITIVE.

END IF

'*** CHECK FOR FEASIBLE M IN SEGMENT 1 ***

D=X(TP)-SUPX(LTSUP)

HY=ABS(SUPY(LTSUP)-Y(TP))

S=SQR(D*D+HY*HY)

E=D*.5

R=OMEGA(%SL)*S

H0=HY/D

E0=E/D

T1LT=T1MAX-OMEGA(%SL)*(SUPY(HISUPPORT)-SUPY(LTSUP))

TUP=T1LT+DX2

IF TUP<(SQR(R^2*E0^2-(R*H0*E0)^2/(1+(H0)^2))+1000) THEN

DX2=(SQR(R^2*E0^2-(R*H0*E0)^2/(1+(H0)^2))+1000)-T1LT

'REDUCING DX2 TO KEEP FEASIBLE M1.

END IF

'*** CHECK FOR FEASIBLE M IN SEGMENT 2 ***

D=SUPX(RTSUP)-X(TP)

HY=ABS(SUPY(TP)-SUPY(RTSUP))

S=SQR(D*D+HY*HY)

E=D*.5

R=OMEGA(%SL)*S

H0=HY/D

E0=E/D

T1LT=T1MAX-OMEGA(%SL)*(SUPY(HISUPPORT)-Y(TP))

TUP=T1LT+DX2

IF TUP<(SQR(R^2*E0^2-(R*H0*E0)^2/(1+H0^2))+1000) THEN

DX2=(SQR(R^2*E0^2-(R*H0*E0)^2/(1+H0^2))+1000)-T1LT

'REDUCING DX2 TO KEEP FEASIBLE M2.

END IF

RETURN

30000' SQUIRREL MAX TENSION PROFILE LEVEL CONTROLLER

GOSUB 2000' MULTISPAN HEADER

GOSUB 20100' ELLIPTICAL LOAD PATH

'FIRST SPAN, SQUIRREL CARRIAGE

```

FOR TP=IYL TO SUPTP(2)-1
SPAN=1
LTSUP=1
RTSUP=2
TILT=RTSUPT(1)
Y(TP)=SUPY(1)-ELLIPTH(TP)
GOSUB 21100'POINT PAYLOAD
IF MLT>SWL(%ML) THEN GOSUB 20300'CORRECT MLT, NORMAL MS
'*** ASSUMES SQUIRREL CARRIAGE IS AT CARRIAGE! ***
IF ABS(SOCRIT-SOTOTAL)>SOERRLIM THEN GOSUB 20200'CORRECT SO
SQX=X(TP):SQY=Y(TP)
THETAJ=0
MINMLHT=HSHT' LOWEST MAINLINE CLEARANCE ABOVE GROUND
CLRTP0=HS' TP OF MINIMUM MAINLINE CLEARANCE
M=M3
MLTTHETALO=THETALO3
FOR CLRTP=HS+1 TO TP-1
D=X(TP)-X(CLRTP)
CALL MLHY(D,M,MLTTHETALO,TP,CLRTP)
MLHT=Y(TP)+MLHY-ELEV(CLRTP)
IF MINMLHT>MLHT THEN
MINMLHT=MLHT
CLRTP0=CLRTP
END IF
NEXT CLRTP
GOSUB 2200'OUTPUT SQUIRREL CARRIAGE RESULTS
IF P<P0 THEN P0=P' SET LOADPATH PAYLOAD
NEXT TP
PRINT#2,"TERRAIN POINT ";TP;" :AT SUPPORT. SUPPORT X = ";SUPX(2)
'SECOND SPAN, SQUIRREL CARRIAGE
FOR TP=SUPTP(2)+1 TO OYL
T1MAX=SWL(%SL)
GOSUB 10200'SUPPORT TENSIONS
GOSUB 31000'POINT SQ PAYLOAD
IF T5MAX>SWL(%ML) THEN GOSUB 34000'MAINLINE TENSION REDUCTION, SQ CAR
MINMLHT=HSHT' LOWEST MAINLINE CLEARANCE ABOVE GROUND
CLRTP0=HS' TP OF MINIMUM MAINLINE CLEARANCE
'LOWER SPAN
M=M6
MLTTHETALO=THETALO6
FOR CLRTP=HS TO TP-1
IF X(CLRTP)>=SQX THEN
D=X(TP)-X(CLRTP)
CALL MLHY(D,M,MLTTHETALO,TP,CLRTP)
MLHT=Y(TP)+MLHY-ELEV(CLRTP)
IF MINMLHT>MLHT THEN
MINMLHT=MLHT
CLRTP0=CLRTP
END IF
END IF
NEXT CLRTP
'UPPER SPAN
M=M5
MLTTHETALO=THETALO5

```

```

FOR CLRTP=HS+1 TO TP-1
  IF X(CLRTP)<=SQX THEN
    D=SQX-X(CLRTP)
    CALL MLHY(D,M,MLTTHETALO,TP,CLRTP)
    MLHT=SQY+MLHY-ELEV(CLRTP)
    IF MINMLHT>MLHT THEN
      MINMLHT=MLHT
      CLRTP0=CLRTP
    END IF
  END IF
NEXT CLRTP
MLTTHETALO=THETALO6
GOSUB 2200'OUTPUT SQUIRREL CARRIAGE RESULTS
IF P<P0 THEN P0=P'      SET LOADPATH PAYLOAD
NEXT TP
RETURN

31000'SQUIRREL MAX TENSION TP LEVEL CONTROLLER
LOADEDSPAN=FNSPAN(TP)
IF ATSUPPORT=%FALSE THEN
  LTSUP=LOADEDSPAN
  RTSUP=LOADEDSPAN+1
  GOSUB 31010'YMIN SECANT
  RX=FERRLIM+1
  Y(TP)=FNCHORD(X(TP))- .2
  GOSUB 31100'SQX
  FDOWNHS=V1LT+V5LT
  FRIGHTHS=FH1+FH5+FHJACK
  FDOWNIS=V3LT-V2RT+VJACK
  FRIGHTIS=FH3-FH2+FHJACK
  FDOWNTS=-V4RT
  FRIGHTTS=-FH4
ELSE
  PRINT#2, :PRINT#2, "TERRAIN POINT";TP;":AT SUPPORTP. SUPPORT X = ";SUPX(2)
END IF
RETURN

31100'SQX HORIZONTAL EQUILIBRIUM SEARCH
' ***SEARCH FROM JACK***
SQX=SUPX(2)-.5
DX=- (SUPX(2)-SUPX(1)-1)/10
DONE=%FALSE
REACHEDLEFT=%FALSE
DO WHILE DONE=%FALSE
  GOSUB 31110'VERTEQ
  IF SQX>=SUPX(2)-.5 THEN'      SQUIRREL CARRIAGE AT REST AGAINST JACK
    IF RX>0 THEN'      FORCE ACTING RIGHT
      FHJACK=RX
      RX=0
      HBAL=%TRUE
    END IF
    IF RY<0 THEN'      FORCE ACTING DOWN
      VJACK=RY
      RY=0

```

```

        VBAL=%TRUE
    END IF
ELSE
    FHJACK=0
    VJACK=0
END IF
IF VBAL=%FALSE THEN
    'SQUIRREL CARRIAGE VERTICAL FORCES UNBALANCED
    IF RY>0 THEN
        SQX=SQX+DX:HBAL=%FALSE
    ELSE
        DX=DX/2:SQX=SQX-DX:HBAL=%FALSE
        'DOWNWARD RESULTANT ON SQUIRREL CARRIAGE
    END IF
ELSEIF VBAL=%TOOHIGH THEN'YMIN>YMAX AT THIS POINT
    IF ABS(DX)>=.5 THEN '    KEEP SEARCHING TO LEFT
        SQX=SQX+DX:HBAL=%FALSE
    ELSE'        SEARCHED ENOUGH, GO TO HEADSPAR
        DONE=%TRUE
    END IF
ELSEIF ABS(RX)<FERRLIM THEN
    'SQUIRREL CARRIAGE IN HORIZONTAL EQUILIBRIUM
    HBAL=%TRUE
ELSE
    'SQUIRREL CARRIAGE HORIZONTAL FORCES UNBALANCED
    IF RX>=0 THEN
        'RIGHTWARD RESULTANT ON SQUIRREL CARRIAGE
        DX=DX/2:SQX=SQX-DX:HBAL=%FALSE:REACHEDLEFT=%TRUE
    ELSE
        'LEFTWARD RESULTANT ON SQUIRREL CARRIAGE
        IF REACHEDLEFT=%TRUE THEN DX=DX/2
        SQX=SQX+DX:HBAL=%FALSE
    END IF
END IF
IF SQX<=(SUPX(1)+.501) THEN
    'SQUIRREL CARRIAGE AT HEADSPAR
    DONE=%TRUE
END IF
IF HBAL=%TRUE AND VBAL=%TRUE THEN DONE=%TRUE
IF ABS(DX)<.01 THEN DONE=%TRUE
LOOP
SLT=T1LT:MLT=T5LT
RETURN

```

31110'VERTEQ VERTICAL EQUILIBRIUM SEARCH

```

    RSQS= "####.## ####.## ####.#### ##### ##### #####.## #####"
##### #####
    RY=FERRLIM+1
    TOOHIGH=%FALSE
    GOSUB 10200'SUPPORT TENSIONS
    S0TOTAL=0
    FOR SPAN=1 TO NUMIS+1
        IF SPAN <> LOADEDSPAN THEN
            GOSUB 10300'S UNLOADED

```

```

        S0TOTAL=S0TOTAL+S0UNLOADED (SPAN)
    END IF
NEXT SPAN
SUNLOADED=S0TOTAL
LOADEDSPAN=FNSPAN (TP)
SMAXVERTEQ=SQR ((YLT-YMIN) ^2+D^2) +SQR ((YMIN-YRT) ^2+ (HSD-D) ^2)
SMINVERTEQ=SQR (HSD^2+ (YLT-YRT) ^2)
YLTVERTEQ=YLT
YRTVERTEQ=YRT
HSDVERTEQ=HSD
DVERTEQ=D
SVERTEQ=SCRIT-SUNLOADED
IF SVERTEQ>SMAXVERTEQ -.0001 THEN SVERTEQ=SMAXVERTEQ-.0001
IF SVERTEQ<SMINVERTEQ+.0001 THEN SVERTEQ=SMINVERTEQ+.0001
Y (TP) =FNELLIPT (YLTVERTEQ, YRTVERTEQ, SVERTEQ, HSDVERTEQ, DVERTEQ, DEBUG)
GOSUB 32000' SQ FORCES AT A POINT
SVERTOLD=SVERTEQ:RYOLD=RY
SVERTEQ=SVERTEQ-.1
IF SVERTEQ>SMAXVERTEQ -.0001 THEN SVERTEQ=SMAXVERTEQ-.0001
IF SVERTEQ<SMINVERTEQ+.0001 THEN SVERTEQ=SMINVERTEQ+.0001
Y (TP) =FNELLIPT (YLTVERTEQ, YRTVERTEQ, SVERTEQ, HSDVERTEQ, DVERTEQ, DEBUG)
GOSUB 32000' SQ FORCES AT A POINT
SVERTREC=SVERTEQ:RYREC=RY
DO WHILE ABS (RY) >FERRLIM AND TOOHIGH=%FALSE
    SVERTEQ=FNSECANT (SVERTOLD, SVERTREC, RYOLD, RYREC)
    IF SVERTEQ>SMAXVERTEQ -.0001 THEN SVERTEQ=SMAXVERTEQ-.0001
    IF SVERTEQ<SMINVERTEQ+.001 THEN SVERTEQ=SMINVERTEQ+.001
    TOOHIGHRETURN:'PROGRAM COMES BACK HERE IF FH6<0
    Y (TP) =FNELLIPT (YLTVERTEQ, YRTVERTEQ, SVERTEQ, HSDVERTEQ, DVERTEQ, DEBUG)
    GOSUB 32000' SQ FORCES AT A POINT
    SVERTOLD=SVERTREC:SVERTREC=SVERTEQ
    RYOLD=RYREC:RYREC=RY
    IF ABS (RY) <FERRLIM THEN
        VBAL=%TRUE
    ELSE
        VBAL=%FALSE
    END IF
    IF INKEY$="E" THEN ERROR 10
LOOP
IF TOOHIGH=%TRUE THEN VBAL=%TOOHIGH
RETURN

32000' SQ FORCES AT A POINT
GOSUB 32200' SEG 3&4
GOSUB 31020' SQY
GOSUB 32300' SEG 5&6
RX=FM2+FM6-FM1-FM5'          UNBALANCED FORCE RIGHT ON SQUIRREL CARRIAGE
RY=V1RT-V2LT+V5RT-V6LT-SQWT' UNBALANCED FORCE UP ON SQUIRREL CARRIAGE
RETURN

31010'YMIN SEARCH FOR LOWEST ALLOWABLE CARRIAGE CLEARANCE BASED ON S0TOTAL
S0TOTAL=0
GOSUB 10200' SUPPORT TENSIONS
FOR SPAN=1 TO NUMIS+1

```

```

IF SPAN <> LOADEDSPAN THEN
  GOSUB 10300'S UNLOADED
  S0TOTAL=S0TOTAL+S0UNLOADED (SPAN)
END IF
NEXT SPAN
LOADEDSPAN=FNSPAN (TP)
SYMIN=SCRIT-S0TOTAL
SPAN=FNSPAN (TP)
YLTYMIN=YLT
YRTYMIN=YRT
HSDYMIN=HSD
DYMIN=D
Y (TP) =FNELLIPT (YLTYMIN, YRTYMIN, SYMIN, HSDYMIN, DYMIN, DEBUG)
ITERATION=0
DELTAS0=S0ERRLIM+1:OLDDELTA=1
ITERATION=ITERATION+1
GOSUB 32200' SEG 3&4
DELTAS0=S0CRIT- (S0TOTAL+S30+S40)
SYMINOLD=SYMIN:DSYMINOLD=DELTAS0
ITERATION=ITERATION+1
SYMIN=SYMIN+.1
SPAN=FNSPAN (TP)
Y (TP) =FNELLIPT (YLTYMIN, YRTYMIN, SYMIN, HSDYMIN, DYMIN, DEBUG)
RL=SQR (HSDYMIN^2+ (YLTYMIN-YRTYMIN)^2)
GOSUB 32200' SEG 3&4
DELTAS0=S0CRIT- (S0TOTAL+S30+S40)
SYMINREC=SYMIN:DSYMINREC=DELTAS0
WHILE ABS (DELTAS0)>S0ERRLIM/100
  ITERATION=ITERATION+1
  SYMIN=FNSECANT (SYMINOLD, SYMINREC, DSYMINOLD, DSYMINREC)
  SPAN=FNSPAN (TP)
  Y (TP) =FNELLIPT (YLTYMIN, YRTYMIN, SYMIN, HSDYMIN, DYMIN, DEBUG)
  IF SYMIN<RL THEN SYMIN=RL
  GOSUB 32200' SEG 3&4
  DELTAS0=S0CRIT- (S0TOTAL+S30+S40)
  SYMINOLD=SYMINREC:DSYMINOLD=DSYMINREC
  SYMINREC=SYMIN:DSYMINREC=DELTAS0
WEND
YMIN=Y (TP)
RETURN

31020'SQY SEARCH FOR SQUIRREL CARRIAGE HEIGHT BASED ON S0CRIT
SQSPAN=FNSPAN (HS+1)
RLSQY=SQR ((YLT-YRT)^2+HSD^2)
SQELLIPTS=RLSQY+.001
SQY=FNELLIPT (SUPY (HS), SUPY (2), SQELLIPTS, HSD, (SQX-SUPX (HS)), DEBUG)
GOSUB 32100' SEGMENT 1 & 2
S0TOTAL=S10+S20+S30+S40
FOR SPAN=2 TO NUMIS+1
  IF SPAN<>LOADEDSPAN THEN S0TOTAL=S0TOTAL+S0ULTP (SPAN, TP)
NEXT SPAN
DELTAS0=S0CRIT-S0TOTAL
DOLD=DELTAS0: XOLD=SQELLIPTS
IF ABS (DELTAS0)>S0ERRLIM/10 THEN

```

```

SQELLIPTS=RLSQY+.2
SQY=FNELLIPT (SUPY (HS) , SUPY (2) , SQELLIPTS , HSD , (SQX-SUPX (HS)) , DEBUG)
GOSUB 32100' SEGMENT 1 & 2
S0TOTAL=S10+S20+S30+S40
FOR SPAN=2 TO NUMIS+1
  IF SPAN<>LOADEDSPAN THEN S0TOTAL=S0TOTAL+SOULTP (SPAN, TP)
NEXT SPAN
DELTAS0=S0CRIT-S0TOTAL
DREC=DELTAS0: XREC=SQELLIPTS
WHILE ABS (DELTAS0)>S0ERRLIM/10
  SQELLIPTS=FNSECANT (XOLD, XREC, DOLD, DREC)
  IF SQELLIPTS<RLSQY+.000001 THEN
    SQELLIPTS=RLSQY+.000001
  END IF
  SQY=FNELLIPT (SUPY (HS) , SUPY (2) , SQELLIPTS , HSD , (SQX-SUPX (HS)) , DEBUG)
  GOSUB 32100' SEG 1 & 2
  S0TOTAL=S10+S20+S30+S40
  FOR SPAN=2 TO NUMIS+1
    IF SPAN<>LOADEDSPAN THEN S0TOTAL=S0TOTAL+SOULTP (SPAN, TP)
  NEXT SPAN
  DELTAS0=S0CRIT-S0TOTAL
  XOLD=XREC: XREC=SQELLIPTS: DOLD=DREC: DREC=DELTAS0
WEND
END IF
RETURN

```

```

32100' SEGMENT 1&2
OMEGA=OMEGA (%SL)
A=A (%SL)
EMOD&=EMOD& (%SL)
TUP=RTSUPT (1)
D=SQX-SUPX (1)
HY=SUPY (1)-SQY
IF HY<0 THEN
  'UPPER END RIGHT
  HY=-HY
  TUP=TUP+OMEGA (%SL) *HY
  CALL M (D, HY, OMEGA, TUP, DEBUG)
  CALL CATFORCES (HY, M, D, OMEGA, DEBUG)
  VIRT=-VUP
  VILT=-VLO
  T1RT=TUP
  T1LT=TLO
ELSE
  'UPPER END LEFT
  CALL M (D, HY, OMEGA, TUP, DEBUG)
  CALL CATFORCES (HY, M, D, OMEGA, DEBUG)
  VIRT=VLO
  VILT=VUP
  T1RT=TLO
  T1LT=TUP
END IF

```



```

FH1=FH
CALL UNSTRETCH(M, TUP, TLO, A, EMOD&, S, OMEGA, DEBUG)
S10=S0
'SEGMENT 2, SKYLINE, SQUIRREL CAR TO FIRST I S
T2LT=T1RT
D=SUPX(2)-SQX
HY=SQY-SUPY(2)
IF HY<0 THEN
  'UPPER END RIGHT
  HY=-HY
  TUP=T2LT+OMEGA*HY
  CALL M(D, HY, OMEGA, TUP, DEBUG)
  CALL CATFORCES (HY, M, D, OMEGA, DEBUG)
  V2RT=-VUP
  V2LT=-VLO
ELSE
  'UPPER END LEFT
  TUP=T2LT
  CALL M(D, HY, OMEGA, TUP, DEBUG)
  CALL CATFORCES (HY, M, D, OMEGA, DEBUG)
  V2RT=VLO
  V2LT=VUP
END IF
FH2=FH
S2=S
CALL UNSTRETCH(M, TUP, TLO, A, EMOD&, S, OMEGA, DEBUG)
S20=S0
RETURN

```

```

32200'SEG 3&4 (TP, Y(TP), LTSUP, RTSUP)
LOADEDSPAN=FNSPAN(TP)
OMEGA=OMEGA(%SL)
A=A(%SL)
EMOD&=EMOD&(%SL)
TUP=RTSUPT(LTSUP)
D=X(TP)-SUPX(LTSUP)
HY=SUPY(LTSUP)-Y(TP)
IF HY<0 THEN
  'UPPER END RIGHT
  HY=-HY
  TUP=TUP+OMEGA(%SL)*HY
  CALL M(D, HY, OMEGA, TUP, DEBUG)
  CALL CATFORCES (HY, M, D, OMEGA, DEBUG)
  V3RT=-VUP
  V3LT=-VLO
  T3RT=TUP
  T3LT=TLO
  THETAJ=PI-THETAUP
ELSE
  'UPPER END LEFT
  CALL M(D, HY, OMEGA, TUP, DEBUG)
  CALL CATFORCES (HY, M, D, OMEGA, DEBUG)
  V3RT=VLO
  V3LT=VUP

```

```

T3RT=TLO
T3LT=TUP
THETAJ=PI-THETALO
END IF
FH3=FB
S3=S
CALL UNSTRETCH(M, TUP, TLO, A, EMOD&, S, OMEGA, DEBUG)
S30=S0
'SEG 4, SKYLINE, CARRIAGE TO RIGHT SUPPORT
T4LT=T3RT
D=SUPX(RTSUP) - X(TP)
HY=Y(TP) - SUPY(RTSUP)
IF HY<0 THEN
  'UPPER END RIGHT
  HY=-HY
  TUP=T4LT+OMEGA(%SL)*HY
  CALL M(D, HY, OMEGA, TUP, DEBUG)
  CALL CATFORCES(HY, M, D, OMEGA, DEBUG)
  V4RT=-VUP
  V4LT=-VLO
ELSE
  'UPPER END LEFT
  TUP=T4LT
  CALL M(D, HY, OMEGA, TUP, DEBUG)
  CALL CATFORCES(HY, M, D, OMEGA, DEBUG)
  V4RT=VLO
  V4LT=VUP
END IF
FH4=FB
S4=S
CALL UNSTRETCH(M, TUP, TLO, A, EMOD&, S, OMEGA, DEBUG)
S40=S0
RETURN

32300'SEG 5&6
OMEGA=OMEGA(%ML)
A=A(%ML)
EMOD&=EMOD&(%ML)
FH6=FB4-FB3
M6=FB6/OMEGA
'*** TEST FOR FEASIBILITY IN MAINLINE
IF FH6<0 OR D/2/M6>30 THEN
  SMINVERTEQ=SQR((X(TP)-SUPX(2))^2+(SUPY(2)-Y(TP)-.1)^2)+
  SQR((YRTVERTEQ-Y(TP)-.1)^2+(HSDVERTEQ-DVERTEQ)^2)
  PRINT#2, USING C15$; "SMINVERTEQ"; "SMAXVERTEQ"; "Y(TP)"; "YMAX"; "YMIN"
  PRINT#2, USING P15$; SMINVERTEQ; SMAXVERTEQ; Y(TP);
  FNELLIPT(YLTVERTEQ, YRTVERTEQ, SMAXVERTEQ, HSDVERTEQ, DVERTEQ, DEBUG);
  FNELLIPT(YLTVERTEQ, YRTVERTEQ, SMINVERTEQ, HSDVERTEQ, DVERTEQ, DEBUG);
  IF SMINVERTEQ>=SMAXVERTEQ THEN
    PRINT#2, "NO FEASIBLE SOLUTION WITH THIS TENSION"
  END IF
  TOOHIGH=%TRUE 'FH<0:NEGATIVE TENSION; D/2/M:EXTREME SLACK, S VERY HIGH
  P=0
  PRINT#2, "Y(TP) TOO HIGH IN 32300.  FH6="; FH6; "D/2/M="; D/2/M6

```

```

GOTO TOOHIGHRETURN
ELSE
  TOOHIGH=%FALSE
  HY=SQY-Y(TP)
  IF HY<0 THEN PRINT "NEGATIVE HY IN SEG 6, SUBR 32300"
  D=X(TP)-SQX
  CALL CATFORCES (HY, M6, D, OMEGA, DEBUG)
  S6=S
  T6LT=TUP
  V6LT=VUP
  V6RT=VLO
  THETALO6=THETALO
  ' SEG 5, MAINLINE FROM HEADSPAR TO SQUIRREL CAR
  T5RT=T6LT
  HY=SUPY(1)-SQY
  TUP=T5RT+OMEGA*HY
  D=SQX-SUPX(1)
  CALL M(D, HY, OMEGA, TUP, DEBUG)
  M5=M
  CALL CATFORCES (HY, M, D, OMEGA, DEBUG)
  V5RT=VLO
  V5LT=VUP
  FH5=FH
  T5LT=TUP
  T5MAX=T5LT
  THETALO5=THETALO
  IF T5RT>T5LT THEN
    PRINT#2, "T5RT>T5LT IN 32300, TP";TP
    T5MAX=T5RT
  END IF
  S5=S
  P=V3RT+V6RT-V4LT-CRWT
END IF
RETURN

33000'SQ LOAD PATH
PRINT#2,
PRINT#2, "LOADPATH, UNSTRETCHED SKYLINE LENGTH=";
PRINT#2, USING "#####.##";S0CRIT;
PRINT#2, ", NET PAYLOAD=";
PRINT#2, USING "#####.##";P0;
GOSUB 2000'MULTISPAN HEADER
FOR TP=HS+1 TO SUPTP(2)-1
  DS=1
  DT=50
  SPAN=1
  T1MAX=SWL(%SL)
  Y2=S0CRIT+S0ERRLIM+1 ' INITIAL ENTRY TO LOOP
  SELLIPT=SELLIPT(TP)
  WHILE ABS(S0CRIT-Y2)>S0ERRLIM OR ABS(P0-Y1)>PERRLIM
    GOSUB 22100'GRADIENT LOADPATH
  WEND
  THETAJ=0
  MINMLHT=HSHT' LOWEST MAINLINE CLEARANCE ABOVE GROUND

```

```

CLRTP0=HS'      TP OF MINIMUM MAINLINE CLEARANCE
M=M3
MLTTHETALO=THETALO3
FOR CLRTP=HS+1 TO TP-1
  D=X(TP)-X(CLRTP)
  CALL MLHY(D,M,MLTTHETALO,TP,CLRTP)
  MLHT=Y(TP)+MLHY-ELEV(CLRTP)
  IF MINMLHT>MLHT THEN
    MINMLHT=MLHT
    CLRTP0=CLRTP
  END IF
NEXT CLRTP
SQX=X(TP):SQY=Y(TP)
GOSUB 2200'OUTPUT SQUIRREL CARRIAGE RESULTS
NEXT TP
PRINT#2,"TERRAIN POINT";TP;":AT SUPPORT. SUPPORT X = ";SUPX(2)
FOR TP=SUPTP(2)+1 TO OYL
  T1MAX=SWL(%SL)
  GOSUB 31000'SQ POINT PAYLOAD
  IF ABS(P-P0)>PERRLIM THEN
    T1MAXOLD=T1MAX
    DPOLD=P0-P
    T1MAX=SWL(%SL)*.9:GOSUB 10200'SUPPORT TENSIONS
    IF T1MAX<MINT1MAX+300 THEN T1MAX=MINT1MAX+300
    GOSUB 31000'SQ POINT PAYLOAD
    T1MAXREC=T1MAX
    DPREC=P0-P
    WHILE ABS(P0-P)>PERRLIM
      T1MAX=FNSECANT(T1MAXOLD,T1MAXREC,DPOLD,DPREC)
      IF T1MAX<MINT1MAX+300 THEN T1MAX=MINT1MAX+300
      GOSUB 10200'SUPPORT TENSIONS
      GOSUB 31000'SQ POINT PAYLOAD
      T1MAXOLD=T1MAXREC
      T1MAXREC=T1MAX
      DPOLD=DPREC
      DPREC=P0-P
    WEND
  END IF
  MINMLHT=HSHT' LOWEST MAINLINE CLEARANCE ABOVE GROUND
  CLRTP0=HS'      TP OF MINIMUM MAINLINE CLEARANCE
  'LOWER SPAN
  M=M6
  MLTTHETALO=THETALO6
  FOR CLRTP=HS TO TP-1
    IF X(CLRTP)>=SQX THEN
      D=X(TP)-X(CLRTP)
      CALL MLHY(D,M,MLTTHETALO,TP,CLRTP)
      MLHT=Y(TP)+MLHY-ELEV(CLRTP)
      IF MINMLHT>MLHT THEN
        MINMLHT=MLHT
        CLRTP0=CLRTP
      END IF
    END IF
  NEXT CLRTP

```

```

'UPPER SPAN
M=M5
MLTTHETALO=THETALO5
FOR CLRTP=HS+1 TO TP-1
  IF X(CLRTP)<=SQX THEN
    D=SQX-X(CLRTP)
    CALL MLHY(D,M,MLTTHETALO,TP,CLRTP)
    MLHT=SQY+MLHY-ELEV(CLRTP)
    IF MINMLHT>MLHT THEN
      MINMLHT=MLHT
      CLRTP0=CLRTP
    END IF
  END IF
NEXT CLRTP
MLTTHETALO=THETALO6
GOSUB 2200'SQ RESULTS
NEXT TP
RETURN

34000'MAINLINE TENSION REDUCTION
IF TP>=SUPTP(2)+1 THEN
  T1MAXOLD=T1MAX
  T5OLD=SWL(%ML)-T5MAX
  T1MAX=SWL(%SL)*.9:GOSUB 10200'SUPPORT TENSIONS
  IF T1MAX<MINT1MAX+300 THEN T1MAX=MINT1MAX+300
  GOSUB 31000'SQ POINT PAYLOAD
  T1MAXREC=T1MAX
  T5REC=SWL(%ML)-T5MAX
  WHILE ABS(SWL(%ML)-T5MAX)>FERRLIM
    T1MAX=FNSECANT(T1MAXOLD,T1MAXREC,T5OLD,T5REC)
    IF T1MAX<MINT1MAX+300 THEN T1MAX=MINT1MAX+300
    GOSUB 10200'SUPPORT TENSIONS
    GOSUB 31000'SQ POINT PAYLOAD
    T1MAXOLD=T1MAXREC
    T1MAXREC=T1MAX
    T5OLD=T5REC
    T5REC=SWL(%ML)-T5MAX
  WEND
END IF
RETURN

```

```

*****
UTIL.BAS
TD, 4/4/88
*****

*** VARIABLE DEFINITIONS AND INITIAL VALUES ***
%SL=1          SKYLINE IDENTIFIER
%ML=2          MAINLINE IDENTIFIER
%HB=3          HAULBACK IDENTIFIER
%SP=4          SLACKPULLING LINE IDENTIFIER
%TRUE=1        NUMERIC VALUE OF %TRUE
%FALSE=0       NUMERIC VALUE OF %FALSE
AS            RESPONSE TO MENU
TP            TERRAIN POINT
NEWTP         TERRAIN POINT DEFINED BY PROGRAM
HS            TERRAIN POINT OF HEADSPAR
TS            TERRAIN POINT OF TAILSPAR
HSHT         HEIGHT OF HEADSPAR, FT
TSHT         HEIGHT OF TAILSPAR, FT
CC            REQUIRED CLEARANCE SKYLINE TO GND, FT
CRWT         CARRIAGE WEIGHT, LB
SQWT         SQUIRREL CARRIAGE WEIGHT, LB
SQX          X COORDINATE OF SQUIRREL CARRIAGE, FT
SQY          Y COORDINATE OF SQUIRREL CARRIAGE, FT
SQELLIPTH    ELLIP LOADPATH DIST FROM SUPPORT TOP TO SQUIRREL CAR, FT
SQCHORD      CHORD HEIGHT ABOVE SQUIRREL CARRIAGE, FT
EFFCRWT      EFFECTIVE CAR. WEIGHT, INCLUDING SQ. CAR., LB
IYL          INNER YARDING LIMIT TP
OYL          OUTER YARDING LIMIT TP
SUPPORT      NUMBER OF SUPPORT (INCLUDES HS AND TS)
ATSUPPORT    %TRUE IF TP IS A SUPPORT
RTSUP        SUPPORT NUMBER OF RIGHT SUPPORT
LTSUP        SUPPORT NUMBER OF LEFT SUPPORT
NUMIS        NUMBER OF INTERMEDIATE SUPPORTS
SPAN         NUMBER OF SPAN
LOADEDSPAN   NUMBER OF SPAN CONTAINING LOAD
S            CABLE SEGMENT LENGTH, FT
SO           CABLE SEGMENT UNSTRETCHED LENGTH, FT
SCRIT        SKYLINE MIN. TOTAL LENGTH, FT
SOCRIT       SKYLINE MIN. TOTAL UNSTRETCHED LENGTH, FT
SOTOTAL      SKYLINE COMPUTED TOTAL UNSTRETCHED LENGTH, FT
STRETCH      STRAIN IN A CABLE SEGMENT
SUP          CATENARY LENGTH TO UPPER POINT OF SEGMENT
SLO          CATENARY LENGTH TO LOWER POINT OF SEGMENT
XUP          CATENARY HORIZ DIST TO UPPER POINT OF SEGMENT
XLO          CATENARY HORIZ DIST TO LOWER POINT OF SEGMENT
EMOD&        MODULUS OF ELASTICITY OF CABLE SEGMENT
A            METALLIC X-SECTION AREA OF CABLE SEGMENT
L#           HORIZONTAL DIST BETWEEN SUPPORTS, FT
Y            VERTICAL DIST BETWEEN SUPPORTS, FT
D            HORIZONTAL DIST LEFT SUPPORT TO TP, FT
C            INTERMEDIATE RESULT
NEWELLIPTH   CORRECTED ELLIP LOADPATH DIST FROM SUPPORT TOP TO CABLE
DELTATIMAX   CORRECTED MAX SL TENSION IN ANALYSIS, (LB)

```

```

'MLCLR          TRUE IF MAINLINE ABOVE GROUND, FALSE IF DRAGGING AT TP
'MLHY          HT OF POINT ON MAINLINE ABOVE CARRIAGE, FT
'LOADTP       TP WHERE CARRIAGE IS LOCATED
'CLRTP        TP WHERE MAINLINE CLEARANCE IS CHECKED
'SYSS$,SYS    CHOICE OF LOGGING SYSTEM,
              1=NORMAL 2=SUSPENDED ML 3=SQUIRREL CARRIAGE
,
'SECANT SEARCH SUBROUTINE VARIABLES:
'XOLD         INDEPENDENT VARIABLE, PREVIOUS TRIAL
'XREC        INDEPENDENT VARIABLE, MOST RECENT TRIAL
'DOLD        ERROR IN DEPENDENT VARIABLE, PREVIOUS TRIAL
'DREC        ERROR IN DEPENDENT VARIABLE, MOST RECENT TRIAL

'2-DIMENSION GRADIENT SEARCH VARIABLES:
'Y1,Y2       INDEPENDENT VARIABLES
'X1,X2       DEPENDENT VARIABLES
'F11        PARTIAL DERIVATIVE OF Y1 WITH RESPECT TO X1, APPROX.
'F21        etc....
'DX1        CHANGE TO ADD TO VARIABLE X1
'DX2        CHANGE TO ADD TO VARIABLE X2

'*** ARRAY DIMENSIONS ***
OPTION BASE 1
DIM X(50)          'GROUND HORIZ. COORD., FT, (TP)
DIM Y(50)          'CABLE VERT. COORD., FT, (TP)
DIM NEWX(50)      'GROUND HORIZ. COORD., FT, (NEWTP)
DIM NEWY(50)      'CABLE VERT. COORD., FT (NEWTP)
DIM ELEV(50)      'GROUND VERT. COORD., FT, (TP)
DIM NEWELEV(50)   'GROUND VERT. COORD., FT, (NEWTP)
DIM T(50)         'SKYLINE TENSION AT TP, LB, (TP)
DIM CHORD(50)     'ELEV. OF CHORD BETWEEN SUPPORTS, FT, (TP)
DIM ELLIPTH(50)   'Y(LTSUP)-Y(TP) ON ELLIPT LOAD PATH
DIM SELLIPT(50)   'LATEST ELLIPTICAL LOAD PATH S, FT, (TP)
DIM MINT1MAX(50) 'MIN SKYLINE TENSION TO ACHIEVE SOCRIT, LB (TP)
DIM LNAM$(5)      'NAME OF CABLE (E.G. SKYLINE, MAINLINE), (LINE)
DIM DIA$(5)       'CABLE DIAMETER, IN, (LINE)
DIM OMEGA(5)      'CABLE WEIGHT, LB/FT, (LINE)
DIM SWL(5)        'CABLE SAFE WORKING LOAD, LB, (LINE)
DIM LL(5)         'CABLE LENGTH, FT, (LINE)
DIM EMO&(5)       'CABLE MODULUS OF ELASTICITY, PSI, (LINE)
DIM A(5)          'CABLE METALLIC CROSS SECT. AREA, IN^2, (LINE)
DIM RTSUPT(10)   'SL TENSION AT RIGHT SIDE OF SUP., LB, (SUP, TP)
DIM LTSUPT(10)   'SL TENSION AT LEFT SIDE OF SUP., LB, (SUP, TP)
DIM SUPTP(10)    'TP OF SUPPORT, (SUPPORT)
DIM SUPX(10)     'X COORD. OF SUPPORT, FT, (SUPPORT)
DIM SUPY(10)     'Y COORD. OF SUPPORT, FT, (SUPPORT)
DIM SUPHT(10)    'HEIGHT OF SL ABOVE GND AT SUPPORT, FT, (SUP)
DIM SLOADED(10)  'LOADED SL LENGTH OF SPAN, FT, (SPAN)
DIM SOLOADED(10) 'UNSTRETCHED LOADED SL LENGTH OF SPAN, FT, (SPAN)
DIM SUNLOADED(10) 'UNLOADED SL LENGTH OF SPAN, FT, (SPAN)
DIM SOUNLOADED(10) 'UNSTRETCHED UNLOADED SL LENGTH OF SPAN, FT, (SPAN)
DIM SULTP(10,50) 'UNLOADED SL LENGTH OF SPAN, FT, (SPAN, TP)

```

```
DIM SOULTP (10,50) 'UNSTRETCHED UNLOADED SL LENGTH OF SPAN, FT, (SPAN,TP)
DIM VARNAMS (50) 'COLUMN TITLES IN DEBUG OUTPUT FILE
```

```
'*** HYPERBOLIC FUNCTIONS ***
```

```
DEF FNSINH (X) = (EXP (X) - EXP (-X)) / 2
DEF FNCOSH (X) = (EXP (X) + EXP (-X)) / 2
DEF FNTANH (X) = (EXP (X) - EXP (-X)) / (EXP (X) + EXP (-X))
DEF FNCOTH (X) = FNCOSH (X) / FNSINH (X)
DEF FNCOSHINV (X) = LOG (X + SQR (X*X-1))
DEF FNSINHINV (X) = LOG (X + SQR (X*X+1))
```

```
'*** OTHER FUNCTIONS ***
```

```
DEF FNARCSIN (X) = ATN (X / SQR (-X*X+1))
DEF FNSECANT (XOLD, XREC, DOLD, DREC) = (XREC*DOLD - XOLD*DREC) / (DOLD - DREC)
```

```
DEF FNCHORD (X)
```

```
  SHARED ATSUPPORT, NUMIS, SUPX (), SUPY (), DEBUG, R8$, C8$
  ATSUPPORT=1
```

```
  FOR SUP=1 TO NUMIS+1
```

```
    IF SUPX (SUP) < X AND SUPX (SUP+1) > X THEN
```

```
      C = (SUPX (SUP+1) - X) * (SUPY (SUP) - SUPY (SUP+1)) / (SUPX (SUP+1) - SUPX (SUP))
```

```
      C = C + SUPY (SUP+1)
```

```
      FNCHORD = C
```

```
      ATSUPPORT = 0
```

```
    END IF
```

```
  NEXT SUP
```

```
END DEF
```

```
DEF FNSPAN (TP)
```

```
  SHARED ATSUPPORT, NUMIS, X (), DEBUG, LTSUP, RTSUP, YLT, YRT, HSD, D, SUPY (), SUPX ()
```

```
  LOCAL I
```

```
  ATSUPPORT=%TRUE
```

```
  FOR I=1 TO NUMIS+1
```

```
    IF SUPX (I) < X (TP) AND SUPX (I+1) > X (TP) THEN
```

```
      FNSPAN = I
```

```
      SPAN = I
```

```
      ATSUPPORT=%FALSE
```

```
      LTSUP = SPAN
```

```
      RTSUP = SPAN+1
```

```
      YLT = SUPY (LTSUP)
```

```
      YRT = SUPY (RTSUP)
```

```
      HSD = SUPX (RTSUP) - SUPX (LTSUP)
```

```
      D = X (TP) - SUPX (LTSUP)
```

```
      I = NUMIS+1
```

```
    END IF
```

```
  NEXT I
```

```
END DEF
```

```
DEF FNELLIPT (YLT, YRT, S, HSD, D, DEBUG)
```

```
'*** GIVES Y COORD. ON ELLIPTICAL LOAD PATH ***
```

```
  SHARED TP, Y ()
```

```
  Y = ABS (YLT - YRT)
```

```
  C = (S*S) + (D*D) - (HSD-D)^2 - Y*Y
```



```

IF YLT>YRT THEN
  ELLIPT=YLT-(C*Y+SQR(-4*D*D*S*S*(S*S-Y*Y)+C*C*S*S))/(2*(S*S-Y*Y))
ELSE
  ELLIPT=YLT-(C*Y-SQR(-4*D*D*S*S*(S*S-Y*Y)+C*C*S*S))/(2*(S*S-Y*Y))
END IF
FNELLIPT=ELLIPT
END DEF

```

```

/**** PROCEDURES *****/

```

```

SUB M (D, HY, OMEGA, TUP, DEBUG)
  SHARED M, S, VUP, TLO, VLO, FH, C8$, R8$
  IF INKEY$=CHR$(27) THEN
    PRINT "PROGRAM TERMINATED BY [ESC] KEY"
  END
  END IF
  ERRLIM=.000001
  S=SQR(D*D+HY*HY)
  E=D*.5
  DELTA=ERRLIM+1
  WHILE DELTA>ERRLIM
    OLDM=M
    R=OMEGA*S
    H0=HY/D
    E0=E/D
    IF (R*H0*E0)^2-(1+(H0)^2)*(R*R*E0^2-TUP*TUP)>0 THEN
      M=(-R*H0*E0+SQR((R*H0*E0)^2-(1+(H0)^2)*(R*R*E0^2-
TUP*TUP)))/(OMEGA*(1+H0^2))
      DELTA=ABS((OLDM-M)/M)
      E=D/2-HY/S*(M-D/2*FNCOth(D/2/M))
      S=SQR(HY*HY+(2*M*FNsinH(D/2/M))^2)
    ELSE
      DM=100
      IF M=0 THEN M=100
      WHILE DELTA>ERRLIM
        SNEW=SQR(HY*HY+(2*M*FNsinH(D/2/M))^2)
        DELTA=S-SNEW
        IF DELTA>0 THEN DM=-DM/2
        IF DELTA>ERRLIM THEN M=M+DM
      WEND
    END IF
  WEND
END SUB

```

```

SUB CATFORCES (HY, M, D, OMEGA, DEBUG)
  SHARED S, VUP, TUP, TLO, VLO, FH, THETAUP, THETALO
  S=SQR(HY*HY+(2*M*FNsinH(D/2/M))^2)
  TUP=OMEGA/2*(S*FNCOth(D/2/M)+HY)
  FH=OMEGA*M
  VUP=SQR(TUP^2-FH^2)
  TLO=TUP-OMEGA*HY
  VLO=VUP-OMEGA*S
  PI=4*ATN(1)
  THETAUP=ATN(VUP/FH)

```

```

    THETALO=ATN (VLO/FH)
END SUB

```

```

SUB UNSTRETCH (M, TUP, TLO, A, EMOD&, S, OMEGA, DEBUG)
SUBNAME$="UNSTRETCH"
  SHARED S0, STRETCH, C8$, R8$
  XLO=M*FNCOSHINV (TLO/ (OMEGA*M))
  SLO=M*FNSINH (XLO/M)
  XUP=M*FNCOSHINV (TUP/ (OMEGA*M))
  SUP=M*FNSINH (XUP/M)
  DELTA=ABS ((SLO+SUP-S)/S)
  IF DELTA<.01 THEN
    'LINE PASSES THROUGH SAG
    XLO=-XLO
  ELSE
    'LINE DOESN'T PASS THROUGH SAG
  END IF
  STRETCH= ((OMEGA*M) / (2*A*EMOD&)) * ((M/2) * (FNSINH (2*XUP/M) -FNSINH (2*XLO/M)) +XUP
XLO)
  S0=S-STRETCH
END SUB

```

```

SUB MLHY (D, M, THETALO, LOADTP, CLRTP)
  SHARED MLHY, ELEV (), Y (), MLCLR, C8$, R8$
  C=SQR ((TAN (THETALO))^2+1)
  B=LOG (TAN (THETALO) +C)
  A=FNSINH (B+D/ (2*M))
  MLHY=2*M*FNSINH (D/ (2*M)) *A
END SUB

```

```

SUB GRADIENT (F11, F12, F21, F22, Y10, Y20, Y1, Y2)
  SHARED DX1, DX2, DEBUG
  IF F11=0 THEN
    DX2=(Y10-Y1)/F12
  ELSEIF F21=0 THEN
    DX2=(Y20-Y2)/F22
  ELSE
    DX2=(Y10-Y1- (F11/F21) * (Y20-Y2)) / (F12- (F11*F22) /F21)
  END IF
  IF F11=0 THEN
    DX1=(Y20-Y2-F22*DX2)/F21
  ELSE
    DX1=(Y10-Y1-F12*DX2)/F11
  END IF
END SUB

```

```

SUB PAUSE
  PRINT "Press any key to continue..."
  ANS$=""
  WHILE ANS$=""
    ANS$=INKEY$
  WEND
END SUB

```

```

'*** SUBROUTINES *****
1000' GENERATE PROFILE
'*** THIS SUBROUTINE GENERATES A PROFILE WITH TWO FLAT SEGMENTS AND INSERTS
'*** 5 EVENLY SPACED TERRAIN POINTS IN THE UPPER SEGMENT AND 5 TERRAIN POINTS
'*** IN THE LOWER SEGMENT, THE FIRST 1 FOOT FROM THE CHORD BREAK, AND THE REST
'*** EVENLY SPACED.
    TPMAX=12                ' 11 TERRAIN POINTS
    PERCENTU=-40            ' SLOPE OF UPPER SEGMENT, PERCENT
    BREAK=5                 ' CHORD SLOPE BREAK, DEGREES, POSITIVE CONVEX
    X(1)=0                  ' HORIZONTAL COORD, FIRST POINT, FT
    ELEV(1)=1000            ' VERTICAL COORD, FIRST POINT, FT
    A=ATN(PERCENTU/100)
    SDU=USP*TSHD/COS(A)     ' SLOPE DIST, UPPER SEGMENT, FT.
    FOR I=2 TO 6
        X(I)=X(I-1)+(SDU/5)*COS(A)
        ELEV(I)=ELEV(I-1)+(SDU/5)*SIN(A)
    NEXT I
    B=A-BREAK*(PI/180)
    SDL=(1-USP)*TSHD/COS(B) ' SLOPE DIST, LOWER SEGMENT, FT.
    X(7)=X(6)               ' TEMP ASSIGNMENT TO EVENLY SPACE TP 7-11
    ELEV(7)=ELEV(6)
    FOR I=8 TO 12
        X(I)=X(I-1)+(SDL/5)*COS(B)
        ELEV(I)=ELEV(I-1)+(SDL/5)*SIN(B)
    NEXT I
    X(7)=X(6)+10           ' LOCATES TP 6 10 FT FROM SLOPE BREAK
    ELEV(7)=ELEV(6)+10*TAN(B)
'*** SET SETTING AND ASSUMPTION VALUES ***
    HS=1:TS=12:TSHT=40     ' HEADSPAR TP, TAILSPAR TP, HEIGHT
    CC=15                  ' CARRIAGE CLEARANCE, FT
    IYL=2:OYL=11          ' INNER AND OUTER YARDING LIMITS
    NUMIS=1                ' NUMBER OF INTERMEDIATE SUPPORTS
    SUPTP(2)=6             ' TERRAIN POINT OF FIRST INTERMEDIATE SUPPORT
    SUPHT(2)=40            ' HEIGHT OF IS ABOVE GROUND
    SUPX(2)=X(6)           ' X COORD OF IS
    SUPY(2)=ELEV(6)+SUPHT(2) ' SL HEIGHT AT IS, DATUM
    LOGL=32                ' LOG LENGTH, FT
    LC=16                  ' TOTAL CHOKER LENGTH, FT
    ELOG=16                ' DIST CHOKER-CTR OF MASS, FT
    LOGDIA=2               ' LOG DIAMETER, FT
    DRAGMU=.6              ' LOG-GROUND COEFF OF FRICTION
    SUPTP(1)=HS
    SUPX(1)=X(HS)
    SUPY(1)=ELEV(HS)+HSHT
    SUPTP(NUMIS+2)=TS
    SUPX(NUMIS+2)=X(TS)
    SUPY(NUMIS+2)=ELEV(TS)+TSHT
    PRINT#2,USING C8$;"TP";"CHORD(TP)"
    FOR TP=1 TO TPMAX
        X=X(TP)
        CHORD(TP)=FNCHORD(X)
        PRINT#2,USING R8$;TP;CHORD(TP)
    NEXT TP

```

```

IF DEVICE$="1" THEN CLS
PRINT#2, SPC(20);"PROFILE DATA":PRINT#2,
PRINT#2,"TOTAL HORIZONTAL SPAN DISTANCE=";TSHD;" ,FT"
PRINT#2,"FRACTION OF TOTAL H.S.D. IN UPPER SPAN=";USP
PRINT#2,"GROUND SLOPE IN UPPER SPAN=";PERCENTU;"PERCENT"
PRINT#2,"CHORDSLOPE BREAK=";BREAK;"DEGREES"
PRINT#2, "TPMAX=";TPMAX
PRINT#2, SPC(22);"GROUND ELEVATION"
PRINT#2, " TP# X COORDINATE Y COORDINATE"
FOR I=1 TO TPMAX
  PRINT#2, USING " ### #####.## #####.##";I,X(I),ELEV(I)
X, Y COORD AT GROUND
NEXT I
IF DEVICE$="1" THEN CALL PAUSE
PRINT#2, SPC(20);"YARDER DATA":PRINT#2,
PRINT#2, "YARDER NAME: ";YNAMS
PRINT#2, USING "& ###";"HEADSPAR HEIGHT";HSHT
PRINT#2, USING "& #####";"CARRIAGE WEIGHT";CRWT
PRINT#2, USING "& ## &";"CARRIAGE DEPTH";YCAR;" ,FT"
PRINT#2, USING "& #### &";"SQUIRREL CARRIAGE WEIGHT";SQWT;" ,LB"
PRINT#2,
PRINT#2, SPC(2);"LINE";SPC(14);"DIAMETER";SPC(2);"WEIGHT";
  SPC(4);"SWL";SPC(7);"LENGTH";SPC(4);"ELAST MOD";SPC(1);"AREA"
PRINT#2, SPC(22);"(IN)";SPC(4);"(LB/FT)";SPC(3);"(LB)";SPC(6);"(FT)";_
  SPC(6);"(PSI)";SPC(5);"(SQ IN)"
FOR I=1 TO 4
  PRINT#2, SPC(2);:PRINT#2,USING "\ " ;LNAMS(I);
  PRINT#2,USING "##.###";DIA(I);
  PRINT#2, SPC(4);: PRINT#2,USING "##.##";OMEGA(I);
  PRINT#2, SPC(4);: PRINT#2,USING "#####";SWL(I);
  PRINT#2, SPC(4);: PRINT#2,USING "#####";LL(I);
  PRINT#2, SPC(4);: PRINT#2,USING "###^^^";EMOD&(I);
  PRINT#2, SPC(4);: PRINT#2,USING "##.#####";A(I);
NEXT I
PRINT#2,
IF DEVICE$="1" THEN CALL PAUSE
IF DEVICE$="1" THEN CLS
PRINT#2, SPC(20);"SETTING DATA":PRINT#2,
PRINT#2,
PRINT#2, "NUMBER OF INTERMEDIATE SUPPORTS: ";NUMIS
PRINT#2, "MINIMUM CARRIAGE CLEARANCE: ";CC
PRINT#2, "INNER YARDING LIMIT: ";IYL
PRINT#2, "OUTER YARDING LIMIT: ";OYL
PRINT#2,
PRINT#2, SPC(30);"TERRAIN HEIGHT TO"
PRINT#2, SPC(31);"POINT SKYLINE (FT)"
PRINT#2, " HEADSPAR";SPC(20)
PRINT#2, USING "###";HS;SPC(7);HSHT
IF NUMIS>0 THEN
  FOR SUPPORT=2 TO (NUMIS+1)
    PRINT#2, " INTERMEDIATE SUPPORT #";SUPPORT-1;SPC(3);
    PRINT#2, USING "###";SUPTP(SUPPORT);SPC(7);SUPHT(SUPPORT);
  NEXT SUPPORT
PRINT#2,

```



```

MLTTHTHALO=(180/PI)*.001*CLNG (MLTTHTHALO*1000)
WRITE#3, TP;MSTYPE$;SLT;MLT;CARCLR;P;SOTOTAL;SQX;SQY;_
FDOWNIS;FRIGHTIS;MINMLHT;CLRTP0;
SQWT;TSHD;USP;PERCENTU;BREAK;X(TP);ELEV(TP);THETAJ;MLTTHTHALO
'RETURN

2200'OUTPUT SQUIRREL CARRIAGE RESULTS
IF SYS=1 OR SYS=2 THEN SQX=0;SQY=0
PRINT#2,USING MSFORMAT$;TP;SLT;MLT;Y(TP)-ELEV(TP);P;SOTOTAL;MINMLHT;FDOWNIS;
FRIGHTIS;SQX;SQY
RETURN
SLT=.001*CLNG(1000*SLT)
MLT=.001*CLNG(1000*MLT)
CARCLR=.001*CLNG(1000*(Y(TP)-ELEV(TP)))
P=.001*CLNG(1000*P)
SOTOTAL=.001*CLNG(1000*SOTOTAL)
SQX=.001*CLNG(1000*SQX)
SQY=.001*CLNG(1000*SQY)
FDOWNIS=.001*CLNG(1000*FDOWNIS)
FRIGHTIS=.001*CLNG(1000*FRIGHTIS)
MINMLHT=.001*CLNG(1000*MINMLHT)
X(TP)=.001*CLNG(1000*X(TP))
ELEV(TP)=.001*CLNG(1000*ELEV(TP))
THETAJ=(180/PI)*.001*CLNG(THETAJ*1000)
MLTTHTHALO=(180/PI)*.001*CLNG(MLTTHTHALO*1000)
WRITE#3, TP;MSTYPE$;SLT;MLT;CARCLR;P;SOTOTAL;SQX;SQY;_
FDOWNIS;FRIGHTIS;MINMLHT;CLRTP0;
SQWT;TSHD;USP;PERCENTU;BREAK;X(TP);ELEV(TP);THETAJ;MLTTHTHALO
'RETURN

2300'OUTPUT FILE HEADER
WRITE#3,DATE$;TIME$;"SUPX(1)=";SUPX(1);"SUPY(1)=";SUPY(1);"SUPX(2)";SUPX(2);
"SUPY(2)=";SUPY(2);"SUPX(3)=";SUPX(3);"SUPY(3)=";SUPY(3)
WRITE#3,"TP";"MSTYPE$";"SLT";"MLT";"CAR CLR";"P";"SOTOTAL";_
"SQX";"SQY";"FDOWNIS";"FRIGHTIS";
"MINMLHT";"CLRTP0";"SQWT";"TSHD";"USP";"PERCENTU";"BREAK";"X(TP)";_
"ELEV(TP)";"THETAJ";"MLTTHTHALO"
RETURN

3000'CHOOSE OUTPUT DEVICE
CLS
CLOSE #2
LOCATE 10,20
PRINT "CHOOSE OUTPUT DEVICE"
LOCATE 12,20
PRINT "1-MONITOR 2-PRINTER 3-FILE OUT.DAT"
DEVICE$=""
WHILE DEVICE$=""
    DEVICE$=INKEY$
WEND
IF NOT (DEVICE$="1" OR DEVICE$="2" OR DEVICE$="3") THEN
    SOUND 523,4
    PRINT "INVALID MENU OPTION -- TRY AGAIN"
    GOTO 3000

```

```

END IF
IF DEVICE$="1" THEN OPEN "SCRN:" FOR OUTPUT AS #2
IF DEVICE$="2" THEN OPEN "LPT1:" FOR OUTPUT AS #2
IF DEVICE$="3" THEN OPEN "OUT.DAT" FOR OUTPUT AS #2
CLS
LOCATE 10,20
PRINT "WORKING..."
RETURN

```

```

4000'DBQ
CLS
LOCATE 10,20
PRINT "CHOOSE OUTPUT TYPE"
LOCATE 12,20
PRINT "1-RESULTS ONLY"
LOCATE 14,20
PRINT "2-DEBUG MESSAGES, VERBOSE"
LOCATE 16,20
PRINT "3-DEBUG MESSAGES, TERSE"
DEBUG$=""
WHILE DEBUG$=""
  DEBUG$=INKEY$
WEND
IF NOT (DEBUG$="1" OR DEBUG$="2" OR DEBUG$="3") THEN
  SOUND 523,4
  PRINT "INVALID MENU OPTION -- TRY AGAIN"
  GOTO 4000
END IF
IF DEBUG$="2" THEN DEBUG=%TRUE
IF DEBUG$="1" THEN DEBUG=%FALSE
IF DEBUG$="3" THEN DEBUG=%TERSE
CLS
LOCATE 10,20
PRINT "WORKING..."
RETURN

```

```

5000'LOAD YARDER
OPEN "MULTI.YRD" FOR INPUT AS #1
  INPUT#1, YNAM$ 'YARDER NAME
  INPUT#1, HSHT 'HEADSPAR HEIGHT, FT
  INPUT#1, CRWT 'CARRIAGE WEIGHT, LB
  INPUT#1, YCAR 'VERT DIST SKYLINE TO BOTTOM OF CAR, FT
  INPUT#1, SQWT 'SQUIRREL CARRIAGE WT, LB
  FOR I=1 TO 4
    INPUT#1, LNAM$(I) 'NAME OF LINE
    INPUT#1, DIA(I) 'DIAMETER OF LINE
    INPUT#1, OMEGA(I) 'LINE WT, LB/FT
    INPUT#1, SWL(I) 'SWL, LB
    INPUT#1, LL(I) 'LENGTH, FT
    INPUT#1, EMOD(I) 'MODULUS OF ELASTICITY, PSI
    A(I)=.465*DIA(I)*DIA(I) 'CABLE X-C AREA, IN^2
    IF EMOD(I)=0 THEN EMOD(I)=12000000
  NEXT I

```