

~~Title~~ 431600
Amount 6160-5
shelf 5704
INV 60900

\$1.50

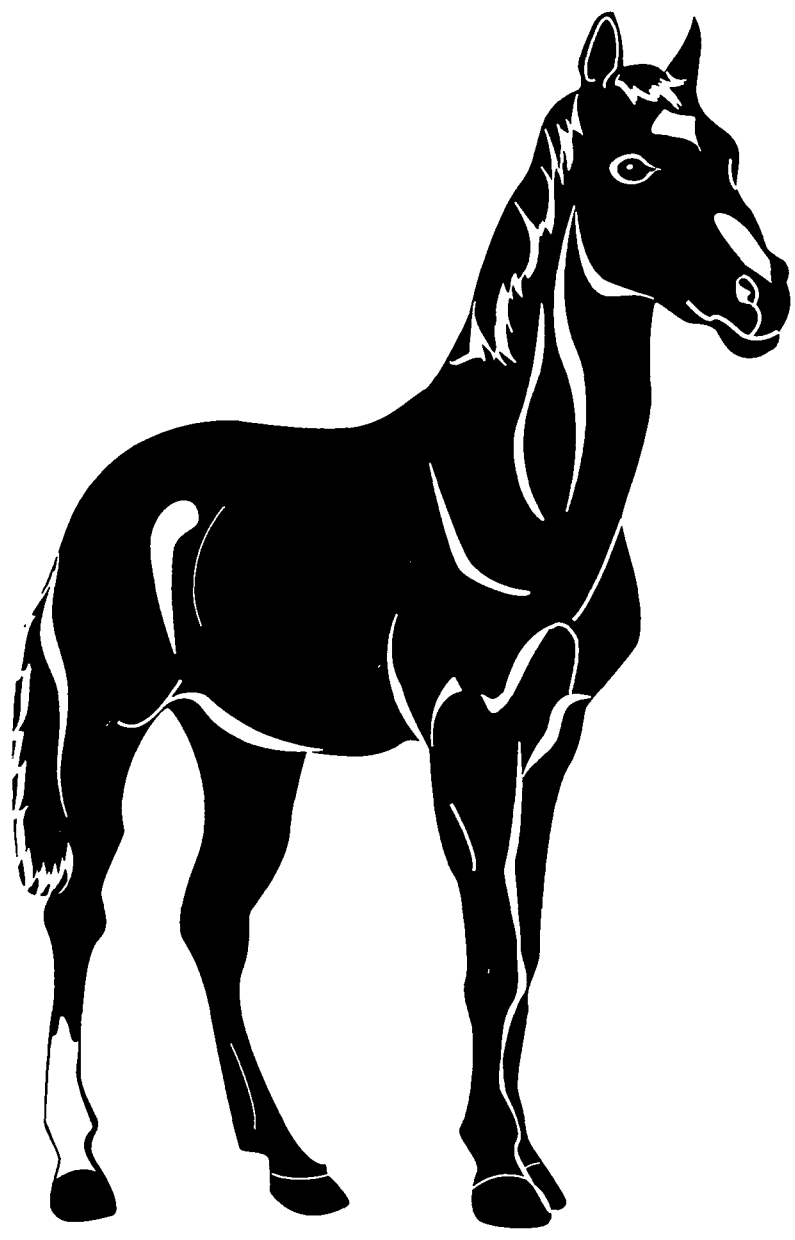

Oregon 4-H
**Horse Contest
Guide**

Guidelines for 4-H horse contests are for members, leaders, and judges. They are general rules for competitive activities with 4-H horses. Contests help members measure progress in knowledge and skill in horsemanship, provide opportunity to learn social skills and sharing, and to have fun. Counties are not bound by state rules except to qualify members for participation at State Fair, but are strongly urged to use them, thereby creating statewide rules for the purpose of uniformity. This makes it easier for leaders to teach and judges to evaluate and assess a member's performance.

Detailed information on the contests described, as well as other contests, is provided by local show committees. In addition, the member, leader, and judge should refer to these support manuals:

- *4-H Hunt Seat and Jumping Manual*, PNW 488
- *4-H Dressage Manual*, 4-H 1311
- *4-H Horse Project*, 4-H 130
- *4-H Colt and Horse Training Manual*, 4-H 1303
- *4-H Driving Manual*, 4-H 1321
- *The E.L. "Dad" Potter Horsemanship Award, Instructions and Application*, 4-H 1302J

Members who wish to participate in open or breed shows should check show rules for tack, dress, and performance requirements.

This publication was revised and written by J. Bradford Jeffreys, Extension specialist, 4-H Youth Development; Shirley Watson, educational program assistant, Oregon State Fair 4-H Horse Show, 4-H Youth Development; Marianne Sharp, educational program assistant, Oregon 4-H Western Gaming Finals, 4-H Youth Development; and Mary Newman, Oregon 4-H leader. This publication was originally prepared by Pat Combest, Carol Jacobson, Sally Kuhl, Vera Roth, Kathy Van Dyke, and Helen Wagner, former Oregon 4-H leaders; with the assistance of Duane Johnson, Extension specialist, 4-H Youth Development; Andy Anderson, associate professor emeritus; Dean Frischknecht, Extension animal science specialist emeritus; Lee Hamilton, former Marion County Extension agent, Oregon State University, and former members of the Oregon 4-H Horse Development Committee.

Contents

General Rules	4
Horse Safety	4
Clothing	5
Western clothing	5
Hunter seat and dressage	5
Saddle seat	5
Showmanship	6
Scoring	6
Showmanship equipment	6
Performance	6
Individual pattern	8
Equitation Contest Procedures	9
Scoring	9
Western equitation	9
English equitation	11
Dressage	11
Equitation over fences	12
Grooming Contest	12
Scoring	12
Ground Training Class	13
Driving	13
Scoring	13
Clothing	13
Safety	13
Equipment	13
Performance	13
Trail Class	14
Western Gaming	15
General information	15
Clothing and tack	15
Gaming equipment	15
Western games	15
Performance	17
Scoring	17
The “Dad” Potter Award	18
Arrangements	18
General instructions to the judge	18
General instructions to the rider	18
Second award	18
Movements required	18
Three-step certificate of merit	19
Herdsmanship	20
Scoring	20

Oregon 4-H Horse Contest Guide General Rules

The grade classifications for 4-H exhibitors are:

- Junior—4th, 5th, or 6th grade.
- Intermediate—7th, 8th, or 9th grade.
- Senior—10th, 11th, or 12th grade or 12th grade equivalent.

Members may show one or more of their owned, leased, or shared project horses, ponies, donkeys, or mules. They should do all grooming and most of the training in preparation for showing. Juniors may receive additional help. To be eligible for State Fair, members must ride, show, or exhibit horses they have owned, leased, and/or trained since June 1, and must use the same horses they exhibited at their county shows.

Members should be courteous and alert and follow instructions given by the judge or ring steward. Enter promptly when the class is called, wearing show ring numbers as required by the show management. If a "gate hold" (delay of class) is necessary for equipment change, request this before the class is called. Unnecessary delays may be penalized.

Attitude is scored. Exhibitors should show confidence and pride in themselves and their animal and should be good sports. Contestants are being judged at all times in the ring. We support and encourage the humane treatment of all animals. Exhibitors are expected to treat their animals with respect and provide for their continuous well-being through proper feeding, handling, disease prevention, sanitation, and attention to their safety.

Equipment must be safe and should be clean, properly adjusted, and suitable for the class in which you show. Members not meeting these standards may lose points or possibly be eliminated. Age or cost of equipment is not considered.

A horse not under control may be dismissed from the ring. A red ribbon on the tail denotes a horse that may kick if crowded.

Horses should be clean and well groomed, with feet trimmed or shod. Fetlocks, muzzle, and bridle path should

be trimmed. The mane and tail may be long, short, or braided. If the tail is braided, the entire mane must be braided. However, if the mane is braided, braiding of the tail is optional. Hoof polish cannot be applied at the State Fairgrounds.

Stallions older than 1 year are not allowed in 4-H horse contests. Ponies and horses should be separate classes whenever possible. Consult show schedule for pony size. The limit is usually 54 inches (13-2 hands).

Riders needing callers will ride last (at the end of a class) so members following them would not benefit more than the members who rode before them.

In 4-H, equitation classes are judged on the skill of the rider. The horse is not judged on conformation.

When judges request a movement to the left (near-side) or right (offside), this is to be the *horse's* left or right. Exhibitors should not pat their horse while being judged in the class.

The judges' decisions are final.

Horse Safety

In managing a horse, safe procedures need to be practiced. With different ages of 4-H youth involved in training horses and involved in many different activities, the opportunity for accidents increases. Exercise care when working and training your horse. Accidents happen when least expected.

Normally a horse is gentle and quiet, but can become excited if it is frightened or mistreated. A gentle, soft voice; slow, easy movements; and a calm attitude will reduce fear and excitement. Be careful with young or unfamiliar horses. An unsafe or careless act may undo hours of careful training. Practice basic safety rules until they become everyday habit.

Recognize the horse's temperament and how it reacts to different situations. Learn to work around a horse and use equipment correctly in order to avoid accidents or injury. Wear boots whenever you are around your horse.

Safety is a very important component of what the 4-H Program values. Decisions that are usually made in the program revolve around the aspect of safety and its impact on members directly, and ultimately, those who provide for their instruction—4-H leaders. The 4-H horse program typically has the largest enrollment of all projects in the Oregon 4-H program. The numbers of youth enrolled combined with the numbers of adult leaders and the fact that a large animal is involved could put youth and the program at some risk in terms of liability.

Few would argue that horseback riding is a dangerous sport, but there have been studies of the risks involved. Many of the risks stem simply from the rider being 4-6 feet off the ground. Even the most placid, well-trained 4-H horse can bolt or rear and throw a rider off. If a horse is running at the time a

The Oregon 4-H Equestrian Headgear Policy

Effective January 1, 1996, all Oregon 4-H members participating in any 4-H equestrian activity, regardless of riding seat, will wear a properly fitted equestrian helmet which meets the minimum performance standards imposed by the American Society for Testing and Materials (ASTM) F1163 and includes certification and labeling required by the Safety Equipment Institute (SEI). Such headgear will be secured with the harness engaged and be properly fastened when mounted on an equine or in a vehicle (cart, wagon, buggy, etc.) being pulled by one or more equines.

rider is thrown, the possibility of serious injury increases. Equipment failure, such as a saddle strap giving way, is another injury risk. Off the horse, the rider is less at risk, but a horse's kick also can be lethal.

Information gathered from the National Electronic Injury Surveillance

System (NEISS) shows that the majority of riding injuries involve the upper body—the head, arms, shoulders, and upper trunk. This pattern is typical of most riding injuries since riders instinctively extend their arms downward while falling from a horse.

Experience is another factor in horse-related injuries. Experienced riders are more likely to be injured than less-experienced riders. However, experience does not necessarily correlate with skill and knowledge in riding; an experienced rider may take more unnecessary chances, or may be riding less-manageable mounts.

Clothing

In keeping with the member's budget, dress should conform to the class as much as possible, either Western or English. Members should be neat, clean, and safely dressed. Long-sleeved shirts are required. Long hair should be worn in nets, braids, or other means to present a neat appearance and a clear view of the show number. Belts should be worn if there are belt loops. Boots are required in all classes. Boots are defined as high topped (above the ankle) leather or leather-like riding shoe with heel. Gloves and ties are optional. "Appointments" refers to clothing and equipment used for showing.

Spurs, if worn, must be used properly: Western spurs must be worn in Western classes and English spurs in English classes.

Effective January 1, 1996, all Oregon 4-H members participating in any 4-H equestrian activity, regardless

of riding seat, will wear a properly fitted equestrian helmet which meets the minimum performance standards imposed by the American Society for Testing and Materials (ASTM) F1163 and includes certification and labeling required by the Safety Equipment Institute (SEI). Such headgear will be secured with the harness engaged and be properly fastened when mounted on an equine or in a vehicle (cart, wagon, buggy, etc.) being pulled by one or more equines. Members and adults wanting more information on the topic of headgear should consult the Oregon 4-H publication *Keeping Oregon Covered*, 4-H 1300L.

Western clothing

A well-fitted plain or Western shirt worn with denim jeans and a plain or Western-style belt are acceptable. Scarves, ties, or other neckwear are optional but encouraged. Pants should be long enough to touch the boot heel when mounted, and can be turned under and pinned neatly when dismounted for showmanship. Chaps are not allowed except in trail.

Hunter seat and dressage

A plain, long-sleeved shirt or long-sleeved turtleneck sweater is required when not wearing a hunt coat. Riders wearing short-sleeved shirts must wear a hunt coat. Riders will wear breeches with high boots or hunt jodhpurs with short jodhpur boots. Additional items may include a hunt coat in conservative color, gloves, a traditional stock tie or four-in-hand tie, and a choker and stock pin.

Saddle seat

Clothing need not be as formal as in open shows, but conservative colors should be worn. Jodhpurs and jodhpur boots are customary. The trousers cover the lower part of the heel when mounted. A plain long-sleeved shirt is required if the optional coat is not worn. Riders wearing short-sleeved shirts must wear saddle seat coats.

A saddle seat coat, usually matching the jodhpurs, may be worn. Gloves, a four-in-hand tie, and a flower in the lapel are traditional, but not required. The total appearance should be one of elegance.

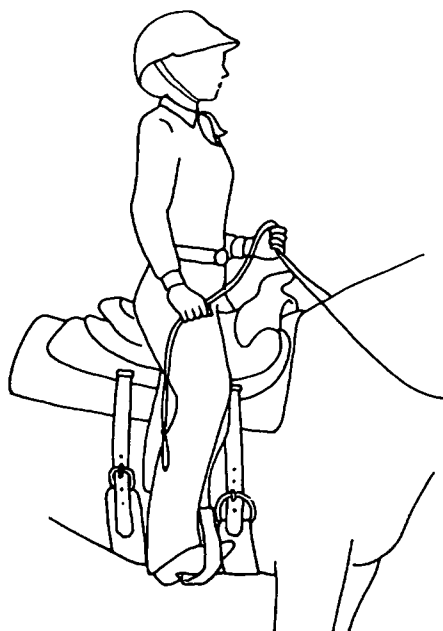

Figure 1. Acceptable Western attire.

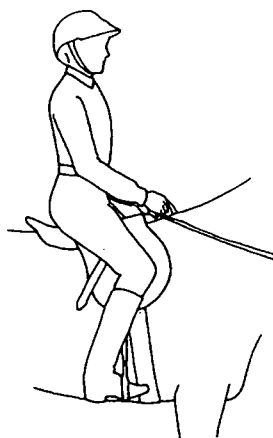

Figure 2. Acceptable hunt seat or dressage attire.

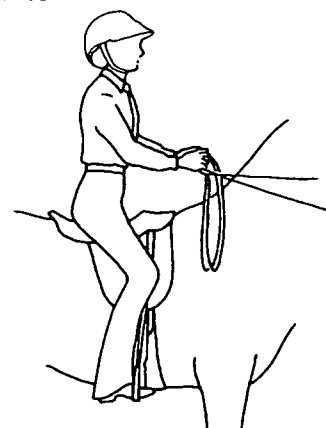

Figure 3. Acceptable saddle seat attire.

Showmanship

Scoring

Member

Neat and clean, properly dressed, prompt and alert, confident (poised), courteous 25

Animal and equipment

Animal clean and brushed, in good condition, feet cared for. Halter and lead fitted, equipment clean and safe 25

Showing the animal

Following directions, leading, turning, standing, backing, stopping, showing to advantage, controlling on lead and in line, attention in line 50
100

Showmanship is a demonstration of the member's ability to show the animal to its best advantage at halter. Conformation of the animal is not considered.

Dress may be Western or English. Boots are required. Spurs are not allowed for safety reasons. Type of headgear for the exhibitor in showmanship is optional. Equestrian hard hats, although not required for showmanship, are encouraged.

Showmanship equipment

The horse may be shown with a safe, properly fitted halter or show bridle (lightweight headstall with a small-ring snaffle and lead, not reins), each complete with a throat latch. A riding bridle is not acceptable. The halter and lead should be leather, rope, or webbing. The lead should be 6 to 8 feet (about 2 m) long. Chains may be properly used under the chin or over the nose when necessary for safety or control. Be sure the lead is long enough to allow picking up a hind foot.

Whips and/or bats are not allowed in showmanship.

Performance

The member should walk ear-to-ear with the horse, about an arm's length from the near side. Hold the lead 6 to 18 inches (15 to 46 cm) from the halter in the right hand with the end folded in a figure 8 in the left hand. Do not coil the lead or fasten it with a rubber band in a figure 8.

Enter the ring at a natural brisk walk in a counter-clockwise direction. The handler is on the inside in order to watch the judge and to avoid being crowded against the wall or fence. Do not crowd the horse ahead or lag behind. *If necessary*, pass on the inside and return to the rail.

When instructed, line up side by side, leaving 6 to 8 feet between horses if possible. Quickly stand the horse square, balanced, or stretched, consistent with the breed and your attire. For example, a horse being shown Western should not be stretched. To pose (square up or set up) the horse, you may hold the lead temporarily in the left hand. The handler should not use his or her feet to touch the horse's hooves. Refer to "Posing" in the *Oregon 4-H Colt and Horse Training Manual*.

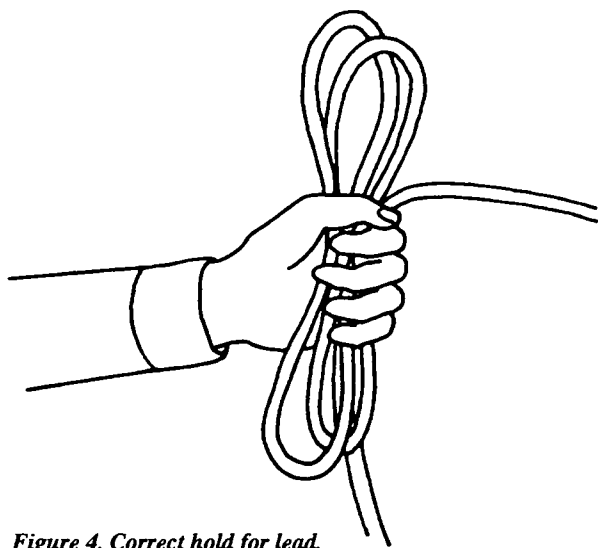

Figure 4. Correct hold for lead.

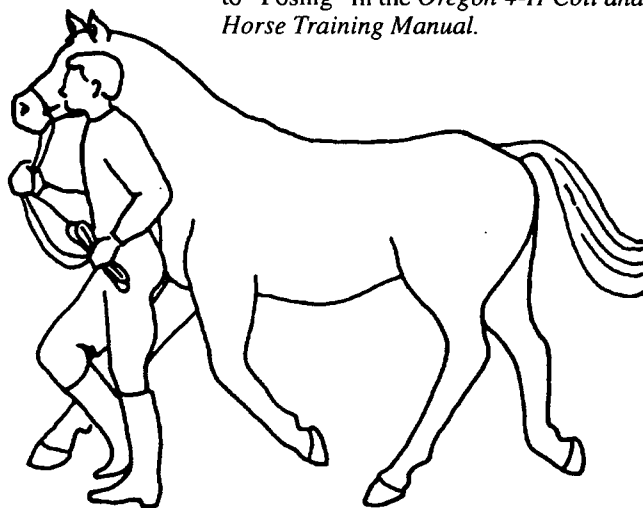

Figure 5. Lead on left side.

Exhibitors should face the horse diagonally at a 45-degree angle off the horse's shoulder in front and to the side of the head, moving from side to side as necessary (see Figure 6). Be in a position to see your horse and keep eye contact with the judge, without blocking the judge's view and without standing directly in front of your horse.

When the judge is in front of the horse or lineup, stand on the opposite side of the horse. For instance, if the judge approaches from the horse's off side, stand to the front and near side of

the animal. After the judge passes, step to the off side.

If the judge is beside or behind the horse, stay on the same side as the judge. For instance, when the judge approaches from the right rear, move to the off side, then cross to the near side after the judge passes behind the horse. Keep eye contact with the judge, moving *smoothly* to the near or off side as the judge approaches and moves around the horse. It is not necessary to change hands on the lead.

Do not let the horse go to sleep, but do not do anything that will attract attention. If the horse moves out of position, quickly reset it. A gelding may "let down" when standing relaxed; correct by moving him forward or back.

If asked to move to another position in line, back out quietly and promptly and lead into place. Speak to the animal to prevent it from becoming startled when another horse is moved nearby. *Quiet* voice commands may be used. Do not pet the horse until the class is dismissed.

Figure 6.

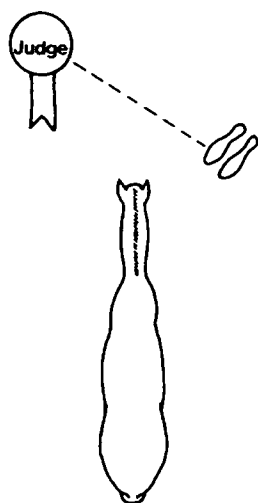

Check 1: Handler should be on the opposite side of the horse when the judge is in front of horse.

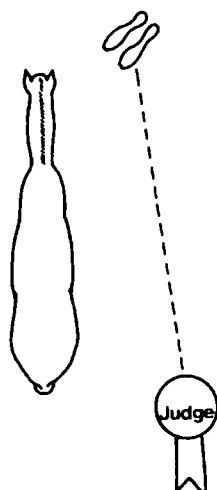

Check 2: Handler should be on the same side of the horse as the judge when judge is beside or behind horse.

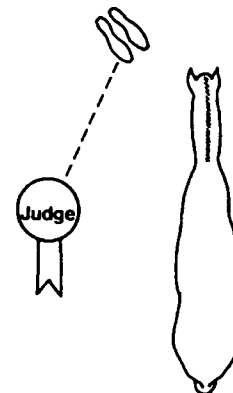

Check 3: Handler must keep eye contact at all times.

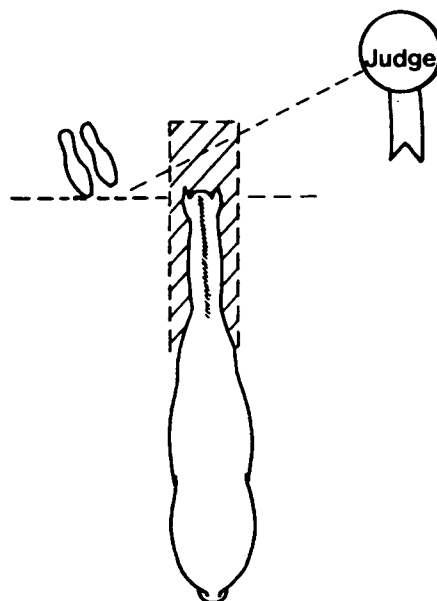

Figure 7. Diagonal position to see off hind foot and whether gelding has "let down." Shaded area is unsafe.

Individual pattern

Showmanship patterns will vary; they should be posted. Some movements the judge may include are: stop, back, pose, trot or walk from either side, forehand or haunch turns, sidepass, or pick up feet. Refer to movements in the *Oregon 4-H Colt and Horse Training Manual*. Questions may be asked from the 4-H project books. Contestants *shall not* be asked to exchange horses. Exhibitors may touch their horses only when requested to perform side pass or forehand turn maneuvers. Exhibitors must not touch the horse when asking for a haunch turn or back.

Listen carefully to instructions. Be ready to move promptly when signaled, and lead to the judge at a brisk walk or trot as instructed. You may be asked to give a front, side, or rear view. Make turns to the right unless it is a quarter turn or less. Stop and stand about 5-7 feet from the judge.

When signaled, lead in a straight line at a brisk walk or trot as directed, giving the judge a clear view of the horse's line of travel. Lead at arm's length from the horse, and do not look back, down, nor at the horse while leading.

At the turning point, hesitate and make a haunch turn to the right. Make a full 180-degree turn, pause, and collect the horse. Do not pose the horse at the

end of the turn. Trot or walk in a straight line as directed. If returning to the judge, make a balanced stop about 5-7 feet from the judge.

To back, face to the rear. Smoothly transfer, but do not drop the lead to your left hand, with the folded end in your right hand. This enables the handler to keep safely off to the side of the horse and not block the judge's view. Keep contact near the halter at all times when transferring the lead from one hand to the other. Back the horse the requested distance in a straight line. Four steps is considered one length. Change hands and lead forward. Pose the horse until excused to return to line. Pass behind the judge if the pattern allows.

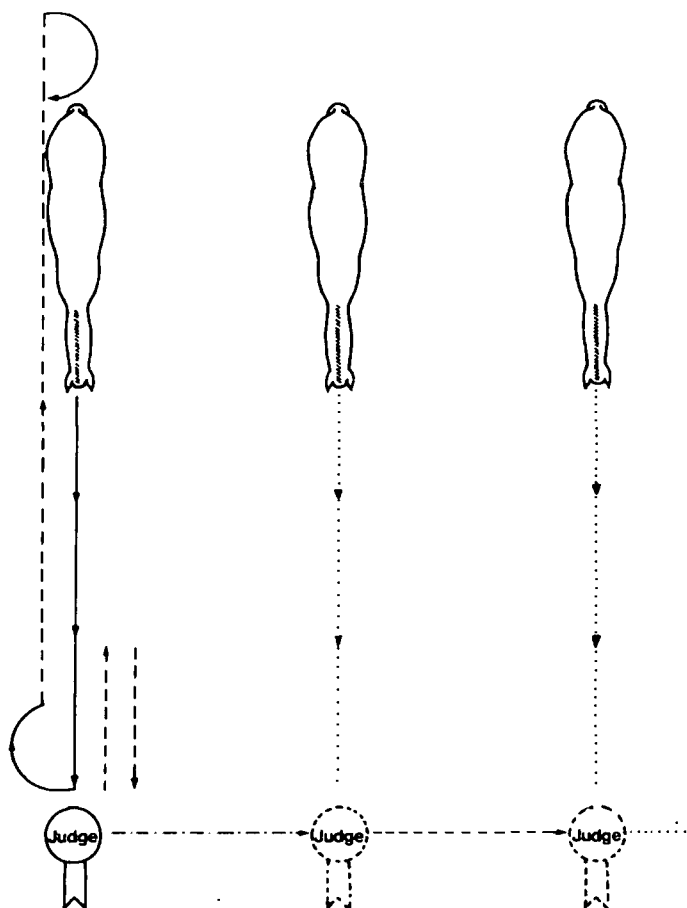
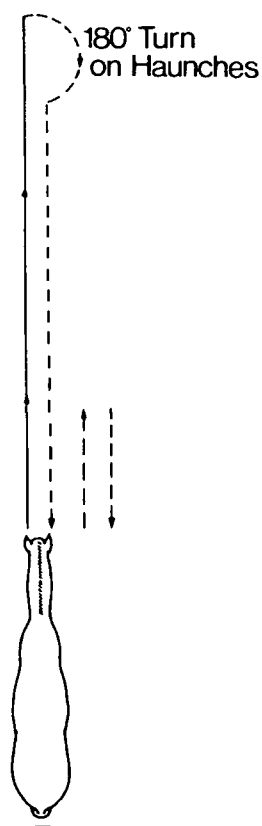

Figure 8. Showmanship pattern options. Judge may move down line.



5-7' from Judge



Figure 9. ...OR Judge stands in one location.

Equitation Contest Procedures

Scoring

Member and appointments

Clothing, equipment, courtesy, poise 15

Seat and hands

Seat, posture, head, legs, hands, balance, distribution of weight, aids 35

Performance

Standing, starting, walking, jog or posting trot, figure 8 or equivalent at lope or canter from walk, stop, turning, backing, general control 50
100

The horse should do what the rider wishes with the least possible effort on the part of the rider and with the least amount of resistance from the horse. Equitation requires more refinement than general horsemanship, but the basics are the same. Refer to "Horsemanship" in the *4-H Horse Project Manual* and the *4-H Colt and Horse Training Manual*.

Gaited horses that pace, slow gait, fox trot, singlefoot, rack, or running walk may be worked with the class, adjusting their speed to conform to the other horses. Riders who ride gaited horses must be able to complete all performance requirements of a class in order to be scored on an equal basis.

The member will be judged on correct posture, smooth gait transitions, and effective use of aids with special emphasis on light hands. The performance of the horse is not to be considered more important than the methods used by the rider in obtaining them.

The show committee or judge may ask for all or part of the movements listed in "Performance," in any order. The patterns may be posted. In addition, the judge may ask for Dad Potter movements, and/or ask questions from the 4-H project books.

The member, horse, and equipment may be inspected at any time during the contest. Members using unsafe equipment may be asked to leave the ring.

Enter the arena to the right in a counter-clockwise direction. Riders will

walk, trot, or canter both ways of the ring as instructed. Stay on the rail unless it is necessary to pass a slower horse; pass on the inside, toward the center of the arena, and return to the rail. Spread out so the judge can observe each horse and to avoid crowding other horses; circle to an open space on the rail if necessary. Reverse direction by turning to the inside, but maintaining the horse's gait. Watch traffic at all times. Riders may be asked to "drop" their stirrups or irons, letting them hang.

Line up, sharing available space, and wait quietly for the individual pattern as posted or directed.

Changes of lead are defined as follows:

- Simple change—drop to walk or trot, change lead.
- Interrupted change—stop completely, start on opposite lead.
- Flying change—change front and rear at canter without dropping to trot or walk.

Juniors and intermediates may use any change, if not designated. For seniors, the show committee or judge may ask for junior or intermediate moves plus any Dad Potter movements. The execution of a flying lead change is preferred for senior 4-H members in both Western equitation and hunt seat equitation. When compared to an equal pattern using an alternative change, credit will be given for a good flying change. A simple or interrupted change performed smoothly is better than a flying lead change done poorly. Exhibitors in a state-level medallion class can be asked any of the movements required for the Dad Potter Horsemanship Award.

On a figure 8, the change is made where the two circles come together. All circles should be round and the same size unless posted otherwise. A serpentine is a series of half-circles which cross an imaginary center line; changes are made at the point where the circle crosses the center line.

The horse should stop easily and balanced in a straight line. Western stops are more abrupt than English halts.

Riders other than juniors may be requested to mount or dismount as part of the performance. It is not mandatory that members check the chin strap or throat latch, but the girth or cinch should be checked and tightened before remounting if necessary. The mount should be one smooth movement, in accordance with the directions in the 4-H project manual.

Western equitation Standard Western equipment

Most types of Western bits, headstalls, and reins are acceptable. Bit lengths longer than 8½ inches are prohibited. (See Figure 9.5.) Mechanical hackamores and hackamore bits are not allowed. Curb straps must be plain leather or chains at least ½ inch wide, and must lie flat against the jaw. Rolled leather straps are unacceptable. A curb strap is not required on a ring snaffle;

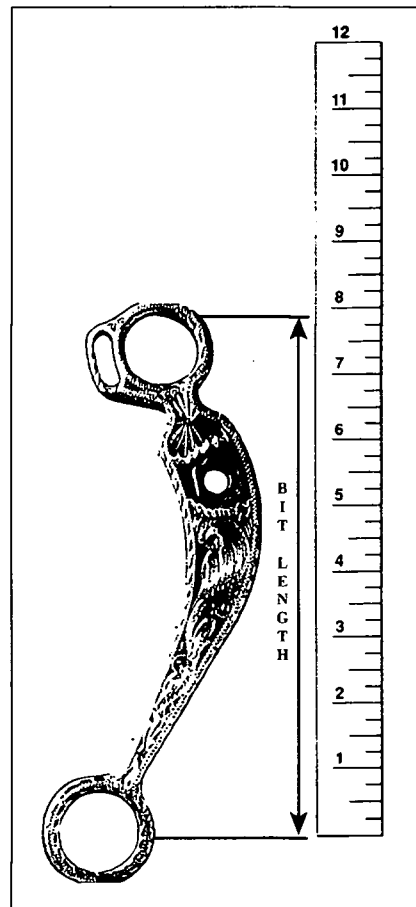

Figure 9.5. Measuring the bit length.

however, if used, it should be below the reins.

A cavesson or noseband is not permitted on Western bridles. Martin-gales or tiedowns are not permitted. Breast collars, lariats (riatas), tapaderos, and hobbles are optional.

Western saddles must be used, with sufficient padding, and should not rest on the withers. If a back cinch is used, it should be adjusted close to the horse and must be attached to the front cinch with a connecting strap.

Junior members may carry a crop or bat if necessary.

Only one hand may be used for reining when using any Western bit with shanks. The rein hand cannot be changed. Two hands should be used

with a snaffle bit or bosal. When romal reins are used, or when the ends of split reins are held in the hand not used for reining, no finger between the reins is allowed. In these cases, the bight of the reins goes on the opposite side from the rein hand.

When split reins are used, the rider may use a finger between the reins, but the bight of the reins must remain on the same side as the rein hand, and the ends are not held. Palms should be down.

The ends of the reins are usually held on the rider's thigh with about 16 inches (41 cm) of rein between the two hands. The position of the hand not used for reining is optional, but it should be kept free of the horse and saddle and held in a relaxed manner.

If a bosal or snaffle bit is used on a horse 5 years old or younger, two hands should be used. When showing horses 6 years old or older, a proper curb bit is preferred with one hand on the reins.

To mount with romal reins, double the end in the left hand. After mounting, slide the bight under the rein hand to the opposite side. For a brief dismount, romal reins need not be taken down; the romal part may be looped *behind* the horn. Both split reins, or the near rein only, may be taken down. Never let go of the reins.

Refer to the *4-H Horse Project Manual* for proper seat and hands.

Performance

Western equitation is often called "stock seat." (Note: In equitation

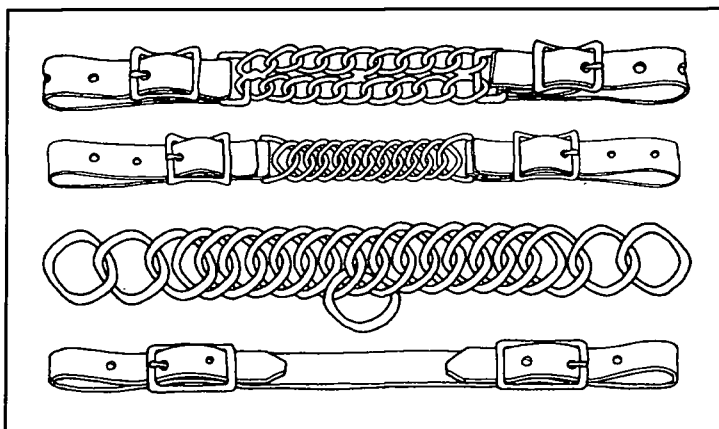

Figure 10. Proper flat chain and leather curb straps.

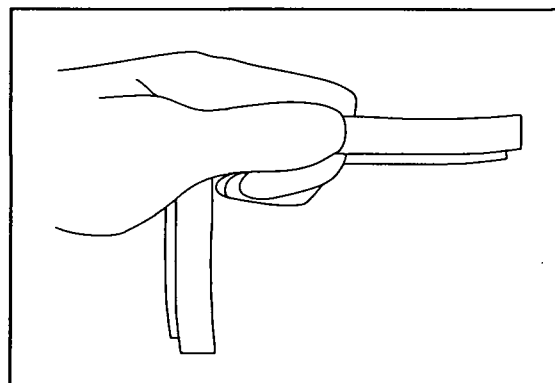

Figure 11. Palms down—split reins entering top of left hand with the bight on the near side.

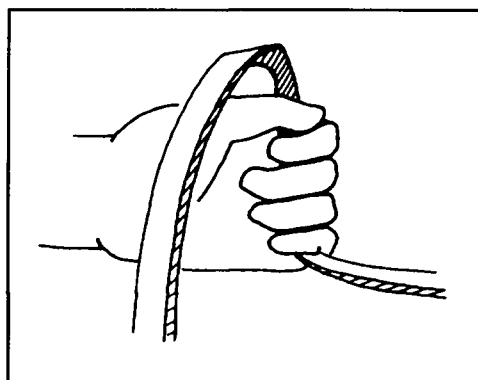

Figure 12. Romal or split reins entering bottom of left hand with the bight falling to off side.

classes the performance of the horse and rider is judged. In pleasure classes the performance, manners, and conformation of the horse are judged.)

Enter the arena at a walk, to the right, in a counter-clockwise direction.

Sit the saddle at the jog trot. At the extended trot, lean slightly forward, keeping contact with the thighs, but do not post.

Juniors may be asked to walk, stop, jog, back, execute turns at a walk, and/or jog, execute figure 8s and/or circles at the lope. Rider may use simple, interrupted, or flying changes.

Intermediates may be asked to lope from the walk, execute a balanced stop, back, execute turns, dismount and mount, execute figure 8s and/or circles at the lope using simple, interrupted, or flying changes.

For seniors, the show committee or judge may ask for junior or intermediate moves, plus any Dad Potter movements.

- Jog circles or extend the trot on the straightaway.
- Ride two figure 8s the same size using optional lead changes.
- On the designated lead, lope past a marker, staying at least 20 feet (about 6 m) from any wall or fence. Make a balanced or sliding stop. A sliding stop receives no extra credit.
- Make a tight turn on the haunches in the direction indicated by the pattern or by the judge.
- Stand 10 seconds, back as directed, and walk to the judge.
- Turn 1/4 turn right, 1/2 turn left, and 1/2 turn right. These turns should be on the haunches.
- Stand for inspection.

English equitation

Equipment

English saddles must be used. It is **required** that hunter seat riders use a jumping, all-purpose, or dressage saddle. Cutback saddles are required for saddle seat classes. English bridles with cavesson, bits, and reins are required. Most standard bits are allowed.

Breastplates or breast collars and saddle pads are optional. Martingales are not permitted. Dropped or flash nosebands and any type of boots are not permitted in flat classes. Bandages are allowed for medical reasons only and a letter signed by the horse's veterinarian must be presented. Whips for saddle seat riders must not be longer than 36 inches (1 m). Hunter seat riders may carry a crop or English-style bat no longer than 24 inches.

Performance

(Note: "Bridle Path Hack" is an English pleasure class for hunter type horses in which the horse is judged. "Hunter Hack" is similar except that two jumps are required.)

There are several methods of holding the reins. To mount, all reins must be picked up at the same time. In saddle seat equitation, the bight of the reins should be on the off side.

To dismount, riders may slide or step down. It is not necessary to take down the reins, but never let go of them. It is not necessary to run up irons when dismounting for brief periods of time.

Enter the ring to the right at a trot. Riders will be asked to walk, do a normal posting or working trot, and canter both ways of the ring. They may also be asked to do a sitting (collected or slow) trot, a working trot, an extended trot, or a hand gallop. These are described in "Horsemanship" in the *4-H Horse Project Manual*.

Juniors may be asked to walk; stop; trot; execute turns at the walk and trot; execute figure 8s or circles at a trot, posting on the outside diagonal; execute figure 8s or circles at the canter, using simple or interrupted changes; and back.

Intermediates may be asked to canter from a walk and make a balanced stop; back; execute figure 8s or circles at a trot, posting on the outside diagonal; execute figure 8s or circles at the canter, using simple or interrupted changes; and dismount and mount.

Seniors may be asked to canter out, execute a balanced stop, and back; execute figure 8s or circles at a trot, posting on the outside diagonal; execute figure 8s or circles at the canter, using an interrupted or simple change; and dismount and mount.

Dressage

Equipment

A dressage or all-purpose hunter-seat saddle is to be used. An English bridle with a plain, smooth English snaffle bit is required. See the *Oregon 4-H Dressage Manual*, 4-H 1311, for types of acceptable bits. A plain snaffle bridle and regular cavesson, flash (a combination of cavesson and dropped), a dropped noseband, or a figure-8 noseband made entirely of leather or leather-like material (except for buckles) is mandatory. The mouthpiece of any bit must be made entirely of the same metal.

Strictly forbidden, under penalty of elimination, are: Martingales, bit guards, accessories (specifically bearing, side, running, or balancing reins, etc.), any type of boots (including "easy boots"), bandages, any form of blinkers, ear muffs, or plugs, nose covers, seat covers, and hoods.

Performance

Test requirements are the same for juniors, intermediates, and seniors. Test is to be ridden and judged according to AHSA and USDF rules. Tests to be used are the current approved AHSA tests. Tests are usually updated by AHSA, and then the Oregon 4-H Program, every 4 to 5 years. Exhibitors should make sure they are using the most current test each year. Tests may be read, but must be limited to reading each movement one time only, as it is written.

Ride is to be judged on horse's gait, impulsion, and submission; the rider's position and seat; and the correctness and effectiveness of the aids. Each movement is scored (0 to 10 points) to establish whether the movement performed was insufficient (4 or below) or sufficient (5 or above). Additional information on how to ride the test and how the test is to be judged can be found in the *Oregon 4-H Dressage Manual*, 4-H 1311.

Equitation over fences

Equipment

A horse should be at least 5 years old before going over jumps.

An English jumping type saddle is required. Stirrup bars must be open. A snaffle bit is preferred, but a pelham is permitted. Twisted wire snaffles are not allowed. Use of spurs, breastplate or

breast collar, and an English bat or crop up to 24 inches long is optional. Martingales are not permitted. Dropped-noseband cavessons may be used and must be below the bit and properly adjusted. Bell boots, splints, and bandages are allowed in the equitation over fences class.

Performance

Performance will be judged on effective use of aids on the entire course. Emphasis will be on light hands, balance, correct posture, and seat on the flat and over fences. Excessive speed will be penalized.

Before taking any jumps, including the warm-up jump, a safety inspection should be done. The inspection will include but is not limited to: making sure that the stirrup bars are open, stitching on stress points of saddle are in good repair, girth is snug, and bridle is properly fitted and also in good repair.

A supervised warm-up jump must be available prior to the class. This warm-up should be limited to one jump and not a jump on the course. The number of times a competitor can practice over the one warm-up jump is to be specified by the local show committee. Preferably, the practice jump should be outside the arena or pattern area.

The course will consist of six to eight jumps with at least one change of direction. Riders may be asked to work over cavaletti (poles placed on ground and spaced for walk, trot, or canter) and jump at the trot and the canter. The judge may ask the class to do rail work at the walk, trot, and canter both ways of the ring.

The rider will be allowed to circle **one time** before starting the course.

Disqualifications are: being off course, a fall of horse or rider, or three cumulative refusals. An additional circle on course will be counted as a fault. At the judge's discretion, disqualified riders may take one fence as they leave the ring.

A refusal will be called when a horse avoids a jump, or stops forward motion. If the refusal is at a combination jump, the rider must retake all elements of the combination. Faults such as knock-downs and touches will not be considered unless they are the fault of the rider.

Recommended fence heights are as follows:

Junior	2 ft. 3 in. maximum
	2 ft. 3 in. spread maximum
Intermediate	2 ft. 6 in. maximum
	2 ft. 6 in. spread maximum
Senior	2 ft. 6 in. maximum
	2 ft. 6 in. spread maximum

Grooming Contest

The purpose of the grooming contest is to demonstrate the member's or team's ability to prepare a horse safely for showing.

Safety is to be observed during cleanup. Work quietly, tie the horse properly, and dress safely. Boots are required.

The team may be two to four members. One or more should be prepared to dress for showing the animal after grooming. They should be well organized in the manner they work on the animal. Teams of mixed age

classes will be judged on the level of the oldest member.

The ability of the members to show their team's effort and the animal also will be judged.

The natural, ungroomed animal will be inspected before and after grooming to determine improvement. Unnatural soiling may be penalized. Hoof trimming or shoeing may have to be done before the contest.

Time permitted may be 1 to 3 hours. If washing is included, ample space and facilities for washing and clipping must

be provided. The cleanup may be supervised.

Questions may be asked from the project book pertaining to grooming or parts of the horse.

Scoring

Quality of grooming	30
General improvement	20
Safety	20
Teamwork, organization	20
Showmanship	<u>10</u>
	100

Ground Training Class

This class is open to weanlings, yearlings, and 2-year-olds. Animals entered in ground training classes are not to have been mounted at any time. Colts may be entered in showmanship, but not equitation or driving. *Only yearlings and 2-year-olds are allowed at state fair.*

All training is to be done by the 4-H member, although they may receive training advice. Training by others, including other 4-H members, makes animal ineligible for class.

Each contestant must give the judge, in advance, a list of steps to be

attempted, age of the member, age of the animal, and the length of training period. Such information can be found on the official Oregon 4-H Ground Training Sheet available at the local county Extension office. The scoresheet is required at the time of judging. Judges will consider how well the steps attempted are accomplished and whether adequate progress has been made during time in training. Do only those items from Step 4-B of the Horse Advancement Program as can be done well in the allotted time. Some county 4-H contests require specific steps. 4-H members should check with their local

county Extension office to see whether specific steps are required.

A maximum time limit of 15 minutes will be placed on each contestant. An enclosed, reasonably quiet area should be provided.

One properly dressed attendant is allowed in the ring. It is preferred that a knowledgeable, properly dressed intermediate or senior 4-H member perform the attendant duties. In the event a member is not available, a properly dressed adult helper/attendant may perform the attendant duties. The role of the attendant is to hold the horse and/or equipment.

Driving

Driving horses may be divided into saddle and draft types. Animals up to 54 inches (13-2 hands) are eligible for pony classes; 1/2 inch will be allowed for shoes.

Scoring

Contestant	15
Equipment.....	15
Performance.....	<u>70</u>
	100

(Performance includes horsemanship of the driver, such as hands, posture, and ability to obtain a proper performance.)

Clothing

The driver may be dressed English or Western and must follow the general horse contest rules. Dresses are not allowed.

Safety

One properly dressed intermediate, senior, or adult helper/attendant is required for the lineup. Attendant should enter the arena once all the entries have lined up. The attendant should not touch the animal except in case of a potential emergency. For safety reasons it is suggested that a knowledgeable intermediate, senior, or adult helper/attendant, properly dressed, be present when harnessing, hitching, unhitching, and unharnessing.

In case of a runaway, all other drivers are to *move off the rail* to the center of the arena and *stay in their vehicles*. Most frightened horses have a tendency to run the rail looking for a way out.

Equipment

The animal is to be shown hitched to a two- or four-wheeled vehicle. The harness and vehicle must be safe and in good condition. *Any entry the judge feels is unsafe may be dismissed whether due to equipment or behavior of the animal.*

The following equipment is required: crupper, blinders, snaffle or driving curb bit, noseband or cavesson, and breeching or thimbles. An overcheck or sidecheck rein is optional.

A driving whip is required. The whip should be long enough so that the lash can reach the horse's shoulder, but a long lash (i.e., a longe whip) is not allowed. It should be carried in the right hand at approximately a 45-degree angle to the horse and ground, held at the most comfortable balance. The whip is a method of communication only. It should not interfere with another driver.

Driving reins may be buckled or unbuckled and must be held in two hands.

Dangling ends of straps on the harness should be secured, e.g., with black electrical tape, as a loose end could catch a rein.

A running martingale, quarter boots, splint (brushing) boots, and kicking strap are optional.

Natural action of the knees and hocks is desirable, but extended feet, weighted shoes, or chains are prohibited.

Animals may be shown with long, braided, or roached manes and natural or braided tail.

Performance

Management should permit only the number of entries that can be shown safely at one time for the size of the ring. Age divisions may be combined if classes are small. Horse and pony classes also may be combined, but each division will be judged separately.

Juniors will enter at a walk to the right in a counter-clockwise direction; intermediates and seniors enter at a slow trot/jog.

The walk should be flat-footed, calm, and even; but energetic, with a determined pace. The slow trot/jog should be slow and on the bit, with impulsion while showing submission to the bit and a steady cadence.

The working trot is a forward moving, free and straight gait, with a taut but light rein. A judge may call for a strong trot (trot on) gait. This gait shows an increase in pace and length of stride while remaining well-balanced. Light contact should be maintained during all gaits.

Gaited horses, such as the Tennessee Walking Horse, may use the intermediate gait instead of the trot. Variance of speeds to be executed as requested. (Extreme speed will be penalized.) Pass other vehicles on the *inside*, watching the traffic. Avoid cutting back to the rail immediately in front of another driver.

Animals may be required to halt and stand quietly at any time. It is permissible to stretch or "park" the animal. Entries may be asked to back. The judge may request individual maneuvers such as a figure 8 at a walk or trot, stop at a designated spot, back as directed, close the back, negotiate a simple obstacle, and/or ask questions from the 4-H books.

Entries will perform both directions of the ring. Reverse at the walk on the diagonal.

Additional classes such as driven dressage or cones/obstacles courses may be offered. See the *Oregon 4-H Horse and Pony Driving Manual*, PNW 229.

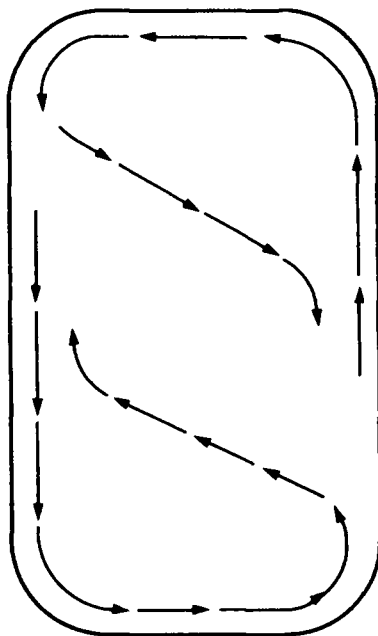

Figure 13. Reversing the ring on the diagonal.

Trail Class

The trail class is a mounted test of horse control and of the rider's ability to guide the horse through a series of obstacles.

The course must be safe for horse and rider. The obstacles may be progressively harder for each age group. They should not be spread out over a very large area; space them to let the horse move easily between obstacles with no wasted time.

Courses should be designed to be completed in less than 5 minutes. Riders may be asked to move to the next obstacle if they have taken more than 30 seconds to start, or they may be allowed three refusals per obstacle, or a combination of the two.

The rider may show English or Western.

Courses must be posted showing the order and direction of the obstacles. Measure and reset each disturbed obstacle for the next rider. Courses should contain 5 to 10 obstacles and be typical of items members might encounter on a regular trail ride. The following obstacles and suggested spacing may be used individually or in combination:

- Open and close a sturdy gate at least 48 inches wide; handle or latch not less than 54 inches from the ground; rider to keep contact with gate and open as if there were animals on the other side.
 - Ride past animal, hide, or noisy object.
 - Remove something that might be found in a mailbox.
 - Walk through brush.
 - Walk over a safe, solid, secure bridge.
 - Back through marked course. Minimum width 28 inches on ground; 30 inches raised; 32 inches for barrels.
 - Side step.
 - Pivots on forehand or haunches within a designated circle.
 - Jumps not more than 18 inches. May be asked to jump horse over, or stop and collect after the jump (not less than 12 feet after jump).
 - Step over logs, 2 x 4s on edge, or poles flat on ground or designed not to roll if raised. Maximum height 12 inches. Set 20 to 24 inches apart for the walk, 3 to 3½ feet for the jog, 6 to 7 feet for lope or canter. Space should be allowed for transitions. Spoke style should be set 24 inches apart halfway out from center.
 - Walk plank placed flat on ground, not less than 12 inches wide.
 - Dismount and mount on near or off side. Juniors will not be asked to mount.
 - Pick up horse's feet.
 - Tie horse properly.
 - Ground tie or hobble inside a minimum 6-foot circle.
- Items considered extremely unsafe and not to be used include stepping into tires, walking on plastic, and cinder blocks for any purpose.
- Each obstacle has a value and is scored according to how the rider maneuvers through the entire obstacle. Judges should give credit for any positive action. The course may be scored by one judge or divided between two or more judges, with each scoring specific obstacles.

Western Gaming

General information

The primary purpose of Western Gaming is to provide an educational forum in which youth enrolled in the 4-H Horse Program demonstrate their ability to navigate a prescribed course in the fastest time possible. Gaming events are timed games on horseback and are individual in nature. Approved 4-H games in Oregon include flag events, figure 8 stake race, barrel and stake, key race, pole bending, keyhole, and Texas barrels. Variations are permitted, but they must be as safe or safer. Other rodeo, racing, and bareback events are prohibited in the Oregon 4-H Program.

4-H Western Gaming supports and encourages the humane treatment of all animals entered in state and county competitions. 4-H exhibitors are expected to treat their animals with respect and provide for their continuous well-being through proper feeding, handling, disease prevention, sanitation, and attention to the animals' safety. 4-H officials should be prepared to dismiss 4-H exhibitors who abuse and mistreat their animals.

4-H contestants must ride horses they have owned, leased, and/or trained since June 1 of the year in which the county or statewide competition is held. The 4-H member must have this horse as a project animal. Contestants must use the same horse they exhibited and qualified on at the county Western Gaming show. Contestants are not

required to use the same horse in both equitation and gaming classes at the state level. Only one Western Gaming horse per competitor can be entered in the state competition.

The following general rules will apply to all gaming events.

Clothing and tack

Use standard 4-H Western clothing. A Western saddle with a saddlehorn is required. Western-type equipment is typically used with the following exceptions: martingales with rein stops, tiedowns used with breast collar, mechanical hackamores, and gagbits are permitted; whips under 36 inches, bats, quirts, crops, and over/under are allowed. Reins must be one piece or knotted. Riders will be disqualified if the judge considers equipment inhumane or dangerous, or if equipment breaks and rider is unable to safely continue without repairs. Spurs, if worn, must be properly used.

Gaming equipment

Plastic 55-gallon barrels are recommended. Metal barrels are strongly discouraged and not recommended for use. If no other alternative exists, metal barrels must have a protective material (a rubber bicycle tire) placed around the upper, outermost portion of the rim, where the barrel could come into contact with the rider's lower leg. Weights should be 45-50 pounds for the

rounded plastic type and 30-35 pounds for the rimmed bottom type. Water or clean, dry sand is recommended as appropriate filler material.

Poles will be 1 inch in diameter, made of material that will not splinter, and painted white. Schedule 40 or 80 white plastic PVC pipe, 60 to 80 inches long, is preferred for poles. Schedule 80 pipe is the most durable. Pole bases can be made of black rubber weighing approximately 14 pounds, dimensions 6 inches tall and 14 inches across. The total weight of the pole and base should be approximately 16 pounds.

An electronic timer and reader board is recommended to time the runs of 4-H exhibitors. At county qualifying gaming competitions, if an electronic timer is not available, a hand-held stopwatch that measures times to the nearest 100th of a second should be stationed at the starting and finishing lines of each game.

Western games

Figure 8 stake race

Four poles are to be used: Two set 120 feet apart at opposite ends of the course, and two center poles set 30 feet apart at a point halfway between the two end poles. These two center poles will mark the start and finish lines. Rider then starts between two center poles and runs a figure 8 around the two end poles with the first turn being optional.

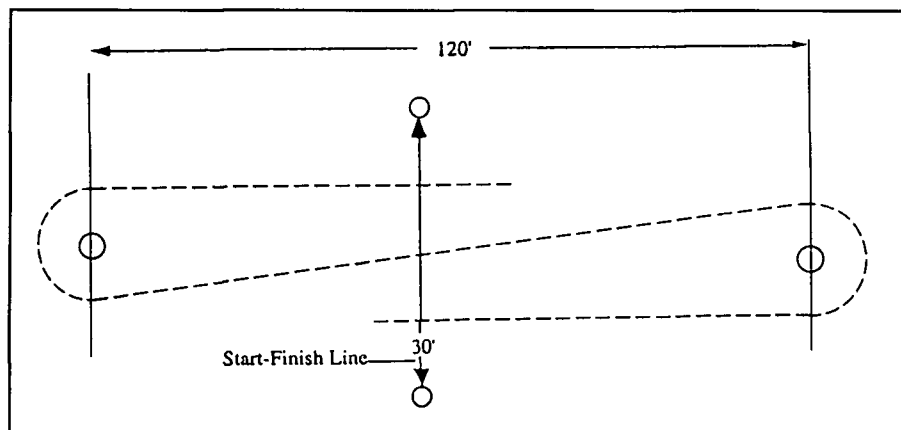

Figure 14. Figure 8 stake race (short course).

Pole bending

Six white poles shall be set in a straight line, spaced 21 feet apart with the start-finish line 21 feet in front of the first pole. The rider crosses the start line, races to pole number 6, bends back through the poles, turns, and races across the finish line.

Key race

Four white poles, covered with a red sock, are placed 5 feet apart at marks 110 and 120 feet from the start-finish line. Rider races between the poles across the turning plane, turns, reverses course through the poles, and finishes.

Texas barrels (short course)

Three barrels shall be placed in a triangular formation. No. 1 and No. 2 barrels are set 33 feet from the start-finish line and 60 feet apart. No. 3 barrel is 80 feet from No. 1 and No. 2 barrels. To square barrels with arena, measure as follows: 30 feet to barrel and 107 feet 7 inches back to middle of starting line, making a triangle.

Rider crosses starting line, circles No. 1 barrel to the right, crosses to No. 2 barrel, circles it to the left, rides to No. 3 barrel, circles it left, and races across the finish line; OR crosses starting line to No. 2 barrel, circles it to the left, crosses to No. 1 barrel, circles it to the right, runs to No. 3 barrel, circles it to the right, and races across the finish line.

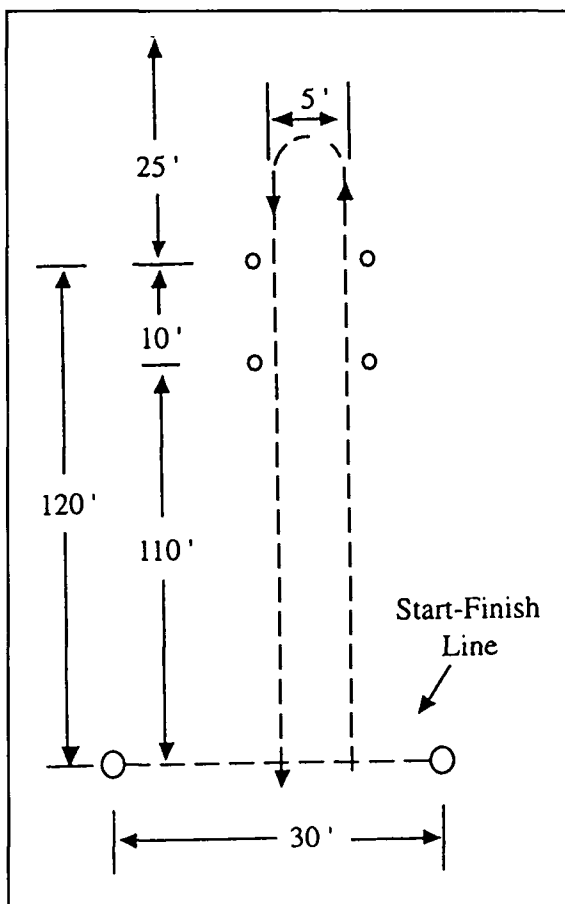

Figure 16. Key race.

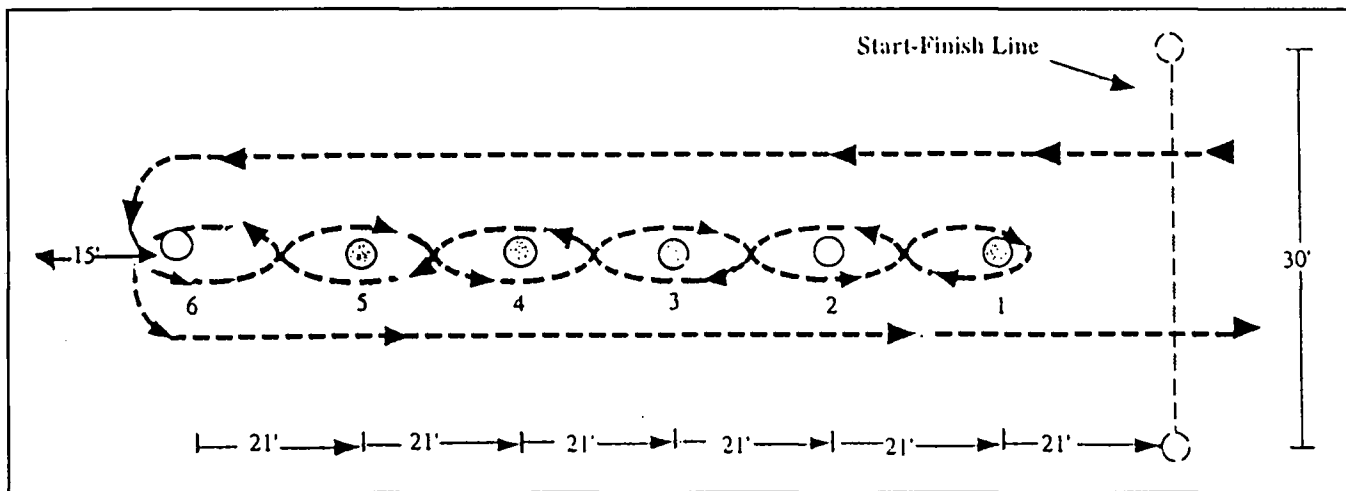

Figure 15. Pole bending.

Although a larger course exists for Texas barrels, the "short course" is the recommended pattern for use in the Oregon 4-H Program.

Keyhole race

The rider crosses the starting line, races 100 feet into a 20-foot-diameter circle marked with white line marker, turns the horse, and returns across the starting line. All four of the horse's feet must stay within the circle.

Performance

As in all other horse events, the 4-H member must be wearing his or her exhibitor number on his/her back at all times while mounted. Horsemanship, sportsmanship, and safety will be stressed in all Western Gaming classes.

Exhibitors at the State 4-H Western Gaming Finals may be asked to submit to a close inspection. The purpose of the close inspection is to demonstrate an exhibitor's ability to handle and control the horse in a safe manner. The close inspection will also provide the show management an opportunity to examine the tack and equipment being used by the 4-H member. Exhibitors failing the close inspection will not be allowed to make their scheduled run in that event. Safety to the exhibitor, the horse, and volunteer adults helping to manage the activity is the most important aspect of the program.

Bats, spurs, and over-and-unders shall be open to inspection by the judges. Spurs, if worn, must be Western spurs. Should these properties be found to be abusive by nature (such as pronged, weighted, or cutting), they shall be banned from use. No warnings shall be required.

Contestants may ride only once in each event. Riders may hold onto the saddle horn. Two hands may be used on the reins, and hands may be changed.

Scoring

4-H members must compete within their appropriate Junior, Intermediate, or Senior age group. The state competition, referred to as the Oregon 4-H Western Gaming Finals, allows only Intermediate and Senior aged youth to enter. Participants are timed and arranged in numerical rank order, then divided into predetermined blue, red, and white ribbon groups. This system is referred to as the modified merit system of judging.

Individuals will receive a basic score equivalent to the number of seconds (at least to the nearest hundredth) that it takes to complete the event. Penalty points are added to this score.

Penalties

For each stake, pole, barrel, or small container knocked down, or knocked

down then righting itself, there will be a 5-second penalty.

Disqualifications include failure to:

- Enter the arena mounted
- Enter the arena without assistance from anyone other than a 4-H member who is also mounted
- Start within 1 minute of the starting signal
- Follow the pattern for an event
- Stay within a lane

Other disqualifications include: run outs, refusals, leaving the course, upsetting starting poles (crossing the starting plane outside of the starting poles and circling any obstacle while on course except flag races and other container events), a horse being unruly or out of control, horse and/or rider tied together except by rubber bands, and spurring or striking the horse in front of the cinch or with property of the event.

A balk is not considered a refusal if the horse finally finishes the course correctly. Any horse that passes (completely) an obstacle on the wrong side will be considered off course.

Judge may disqualify rider for unsportsmanlike conduct, profane language, unnecessary roughness, abusing the horse, and disorderly conduct of any kind. The judge may also disqualify an unmanageable horse for reasons of safety or the exhibitor's inability to handle or control the horse.

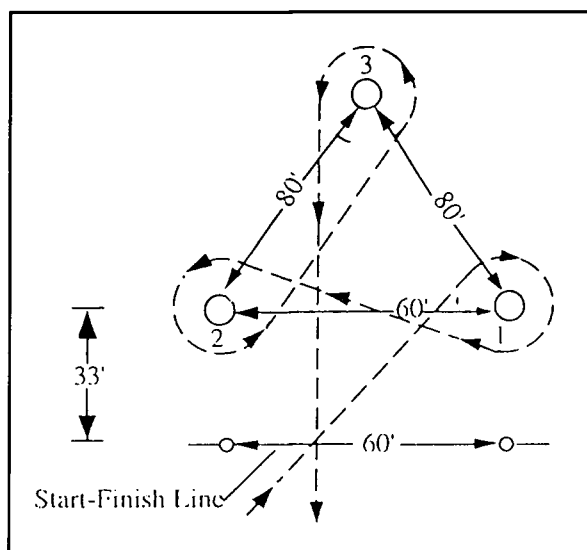

Figure 17. Texas barrel race short course.

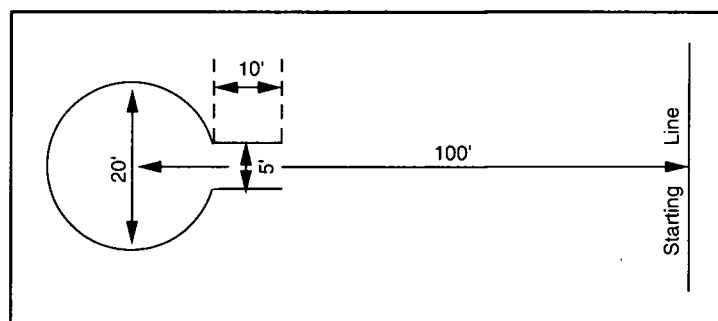

Figure 18. Keyhole race.

The "Dad" Potter Award

The E.L. "Dad" Potter 4-H Horsemanship Medal is sponsored in memory of E.L. Potter, OSU professor and expert horseman, teacher, and developer of 4-H horse projects.

Riders may be Juniors, Intermediates, or Seniors enrolled in Oregon 4-H who have passed steps 1, 2, and 3 of the Horse Advancement Program. 4-H members must have owned and/or cared for and personally trained the horse used for at least 6 months.

The trial is a test of finished horsemanship for horse and rider. The horse must be quiet, well mannered, and under full control. The rider must use seat, hands, and leg aids properly.

The horse must be in good condition and well groomed. Equipment and the rider's dress must be suitable, neat, clean, safe, and in good condition. Equipment must be either English or Western. Spurs, if worn, may be removed between movements.

Arrangements

Arrangements for scheduled trials must be made with the approval of a county agent of the OSU Extension Service and a 4-H leader. This will include the time, place, and the acquisition of an approved "Dad" Potter judge as noted on the most recent version of the Oregon 4-H Judges List. Trials approved by non-certified Judges who misrepresent their status on the list will have the application rejected when it is sent to Oregon State University for approval. Trials are often held in conjunction with fairs, but this is not necessary. They must be announced early enough so that all interested members have an opportunity to participate. Members may participate in multi-county tryouts. Spectators should be encouraged to attend.

The area in which the trial is conducted should be a minimum of 50 x 100 feet of smooth, level ground with good footing. The judge should inspect this personally, and the rider and horse should have time to become acquainted with the area. There should be no distractions. If the judge decides that an error is due to outside distractions, the member should be provided a brief time to calm the horse and may repeat the movement without penalty. The rider may select the sequence for each movement and should indicate when it is being started.

The signed form must be presented to the judge before the test begins. The order of movements must be listed in the column on the left side of the score sheet, as the rider wishes, except Number 10 cannot be done first.

General instructions to the judge

Have a measuring tape or device and a watch with a second hand. Keep in mind this is not a dressage test of unified movements; it is a series of individual tests. Riders should be permitted to relax their mounts briefly between tests by making a circle or two, or taking a few steps for better footing or location.

General instructions to the rider

Only one error is allowed and it must be corrected, either at once or later during the trial, as decided by the rider. Any additional error will disqualify the 4-H'er. If all movements are completed with only one error which was corrected, the member will qualify. Contestants who fail are eligible for

future trials, but not on the same day. In case the above requirements are not met to the full satisfaction of the judge, the judge is authorized and instructed to refuse an award.

Second award

If the member is competing for a second "Dad" Potter medal, it must be done with a second horse the member has raised and trained from a foal. All training must be done by the member. The application for the award must be accompanied by a statement that the member has raised and trained the animal from foal to a completely trained horse.

Movements required

1. Walk forward and backward the exact number of steps indicated by the judge; repeat two more times. The rider must specify the *exact way* the steps will be counted (all four feet or a specific foot). The number of steps requested may vary for each repeat. Do not count the last half step to bring the feet even. The front feet should be approximately within half the hoof's length of being even at the end of each move. An inadvertent half step in the opposite direction is a fault (i.e., a half step forward when collecting the horse to back).
2. Side step right and left as requested with at least 12 steps, or six crossovers, in each direction (one crossover is two steps); repeat. The forefoot must cross in front of the stationary foot. The hind feet must cross in front or be placed side by side. Balance the horse before changing directions.

3. About on the forehand, *full* 360 degrees one way and then the other; repeat. The horse may be repositioned before repeating. *The movement must be done with forward motion*, with no backing around the pivot foot. Pivot foot must be the inside forefoot. It may move within a 24-inch diameter circle (12-inch radius from the starting point). *The rider must not be asked to place the horse inside a circle drawn on the ground*. The judge will be prepared to measure a questionable distance. Keep forward motion.
4. About on the haunches, *full* 360 degrees one way and then the other; repeat. Pivot foot must be the inside hind foot. It may move within a 36-inch-diameter circle (18-inch radius from its starting point). Keep *forward* motion.
5. Two track at least three times in each direction as requested at a walk or trot. The horse's body must be kept straight ahead while tracking at a 45-degree angle. Forward motion must be combined with side motion in a consistent 45-degree line of travel. Allowing the horse to lead with its shoulders, then quarters, is not acceptable. The distance each way must be reasonable and not tire the horse. Two steps forward motion are allowed before the horse changes direction. The rider should not be asked for an exact number of steps.
6. Start a jog trot from a standing position; repeat two or more times. No walking steps are allowed. The *diagonal* feet should come up at the same time to start the two-beat trot. Proper collection and impulsion are required for a smooth start. Do not post.
7. Post the trot on a straightaway, starting on either diagonal, changing diagonals at least three times as requested by the judge; repeat two more times. Demonstrate good equitation and smooth changes with no extra "bumps."
8. Perform one figure 8 at the posting trot (change to the correct diagonal at the trot), then without halting execute a second figure 8 at the canter, using a simple change of lead. Halt. Execute a third figure 8 at the canter, using an interrupted change of lead. Start the canter from the halt, with no walking or trotting steps.
9. Execute one figure 8 demonstrating two complete flying changes of lead, continuing on to two circles to the right (or left). Make a third complete flying change and two circles to the left (or right). Halt at starting point. Change of leads may be executed with either the front or rear legs changing first. A delayed half stride in the rear, or disunited change, is not allowed.
10. Starting from a walk and at least 20 feet from a wall or fence, pick up a canter immediately. Execute two complete flying changes of lead on the straightaway. Maintaining the canter, return to center of the arena and halt. Allow the horse to settle and stand for 30 seconds without moving any foot. (Thirty seconds are allowed to settle the horse.) The rider will indicate to the judge when the 30-second count should start, and this will be timed with a watch.

The horse must not be canted, or angled, for the lead changes; only a slight leading of the correct shoulder and haunch is acceptable. Trotting steps, a disunited change, resistance by the horse, charging, or unplanned changes are not acceptable.

Three-step certificate of merit

The purpose of the three-step E.L. "Dad" Potter 4-H Certificate of Merit is to provide an incentive to Oregon 4-H members to perfect and attempt movements 1–10 in the "Dad" Potter Program. This three-step program is optional for the 4-H member.

The certificate of merit is awarded to 4-H members as they perfect and attempt the movements in sequences of three (in any order, e.g., 1, 5, 3; 4, 6, 8; and 7, 2, 10). A certificate and 4-H merit emblem is awarded for the first three movements completed. Subsequent movements, completed in increments of three, would be recognized by the member receiving a 4-H merit emblem for attachment to the certificate. All instructions, arrangements, and requirements that apply to the "Dad" Potter 4-H Horsemanship Award will apply to the Three-Step Certificate of Merit with the following exceptions:

1. The Three-Step Program is *not* designed as a consolation award for members attempting the 10 steps as a part of the "Dad" Potter Horsemanship Award. Members must decide the three specific movements they will attempt prior to the test (e.g., steps 3, 2, and 10 for the certificate).
2. Any three of movements 1 through 10 may be attempted at one time. No errors will be allowed during the trial of three movements selected by the 4-H member.
3. Only three steps may be completed on a given day. Movements, once completed by the member, cannot be repeated in future sequences. Members cannot compete for a separate second certificate unless they use a horse they have raised and trained from a foal.

Once the 4-H member has completed nine steps as designated on the certificate, he or she shall be encouraged to try out for the E.L. "Dad" Potter 4-H horsemanship medal, which requires the member to accomplish all 10 movements at one time.

Herdsmanship

The 4-H Herdsmanship Contest encourages 4-H members to make a presentable exhibit for the public and helps develop teamwork, cooperation, and pride. It involves courtesy, cooperation, neatness, safety, and proper care of animals. Leaders and parents are encouraged to give guidance, but members must do their own work.

All materials used in decorations must be fire retardant.

Scoring

Members

To be observed when present; continuous attendance not required. Neat and clean appearance. Exhibit friendliness, courtesy, cooperation, and positive attitude. Work must be done by members. Wear boots or hard-soled shoes at all times. Completed stall cards visible from front of stall. Decorations appropriate to fair theme and, when possible, incorporating educational information 40

Animals

Securely tied or stalled, clean and comfortable, regularly fed and cared for. No saddled horses left unattended in stalls 30

Exhibit area

Clean pens, stalls, and alleys for visitors; feed and equipment safely stored or fastened in stall. Secure stall door. Neat and orderly tack and feed area 30

100

© 1999 Oregon State University

This publication was produced and distributed in furtherance of the Acts of Congress of May 8 and June 30, 1914. Extension work is a cooperative program of Oregon State University, the U.S. Department of Agriculture, and Oregon counties.

Oregon State University Extension Service offers educational programs, activities, and materials—*without regard to race, color, religion, sex, sexual orientation, national origin, age, marital status, disability, and disabled veteran or Vietnam-era veteran status*—as required by Title VI of the Civil Rights Act of 1964, Title IX of the Education Amendments of 1972, and Section 504 of the Rehabilitation Act of 1973. Oregon State University Extension Service is an Equal Opportunity Employer.

Revised July 1999. Reprinted July 2000.